

LINSY

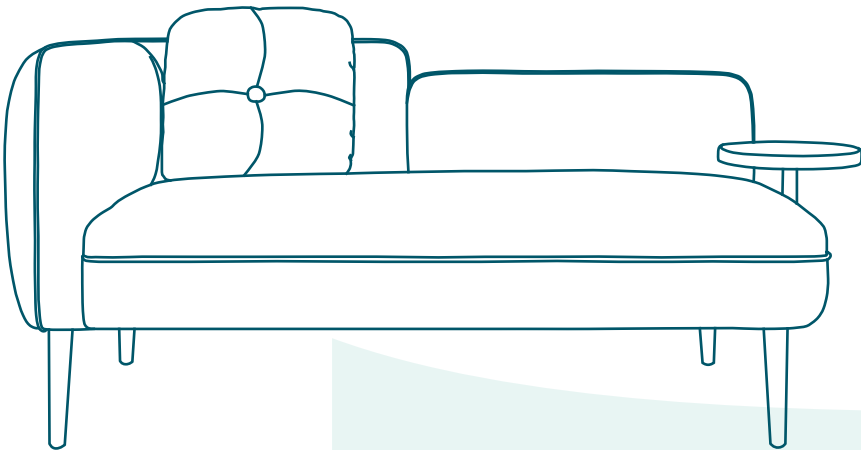

Sofa - HS926
Support@linsy.com

Assembly Instructions

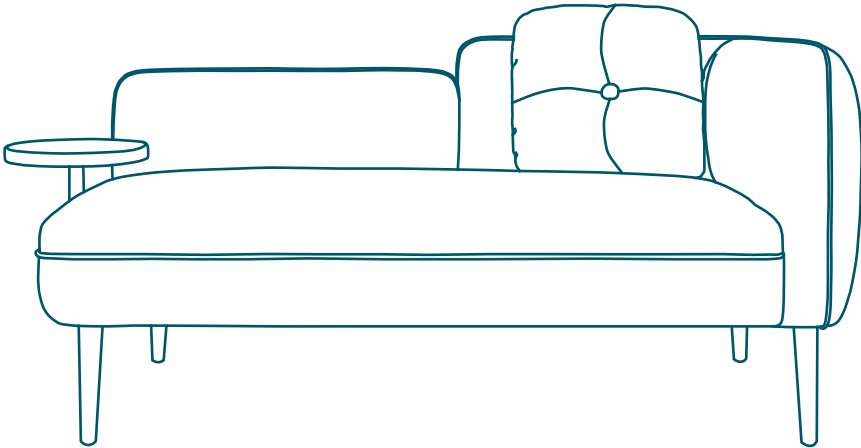

Safety And Care Advice

Important – Please read these instructions fully before starting assembly.

Please check if all the components and tools listed out are received.

Please remove all fittings from the plastic bags and separate them into homologous groups.

Please keep children and animals away from the working areas; swallow small parts may cause suffocation.

Please make sure you have enough space to lay out the parts before starting.

Do not stand on the product, which could cause damage.

Please assemble the product as close to its final position as possible.

Do not place furniture directly in front of radiators, fires, or any other source of heat.

The assembly will be easier with 2 people.

Please dispose of all packaging carefully and responsibly.

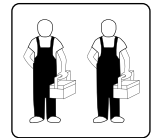

General care and maintenance

Please clean with a damp cloth or mild detergent, do not use bleach or abrasive cleaners.

Do not allow the spill to stay on the surface for a long time.

Do not clean with products containing the following: acetone (e.g., nail varnish remover), ammonia (e.g.bleach), or sodium hydroxide(e.g., caustic soda, drain, and oven cleaners).

If the product is accidentally exposed to the irritating liquid, rinse thoroughly with clean water.

Mats can be used to protect surfaces from moisture and heat.

Please check whether there are missing screws in the product regularly.

The product should not be discarded with household waste, and please take it to your local authority waste disposal center.

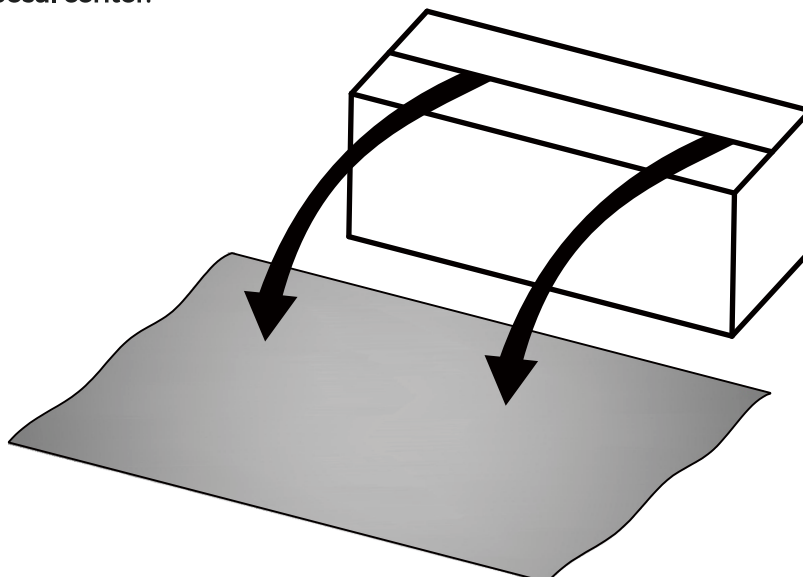

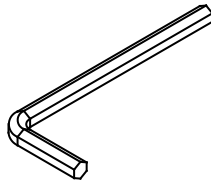

1x

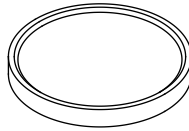
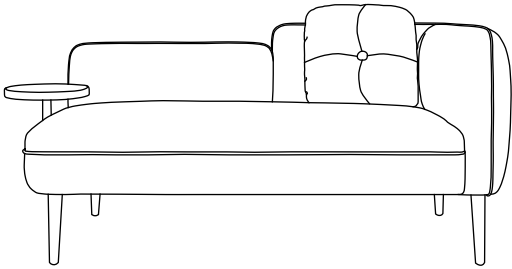

1x

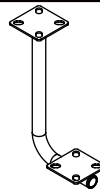

1x



5/16*15mm
4x



5/16*25mm
4x



8x



4x



4x

OR /1x

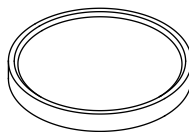
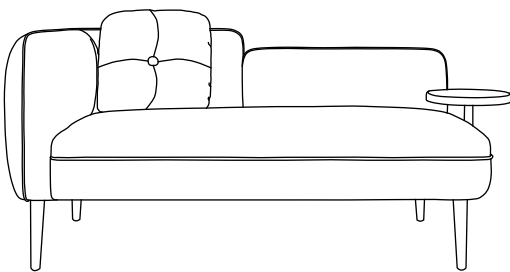

1x

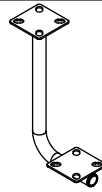

1x



5/16*15mm
4x



5/16*25mm
4x



8x



4x



4x



Please note that if you purchase the right chaise sofa, its hardware components are identical to those of the left chaise sofa, and the installation process can follow the guidelines for the left chaise model.

1

Unbox the Items

Put the base upside down, unzip the bottom of the base and carefully take out the items.

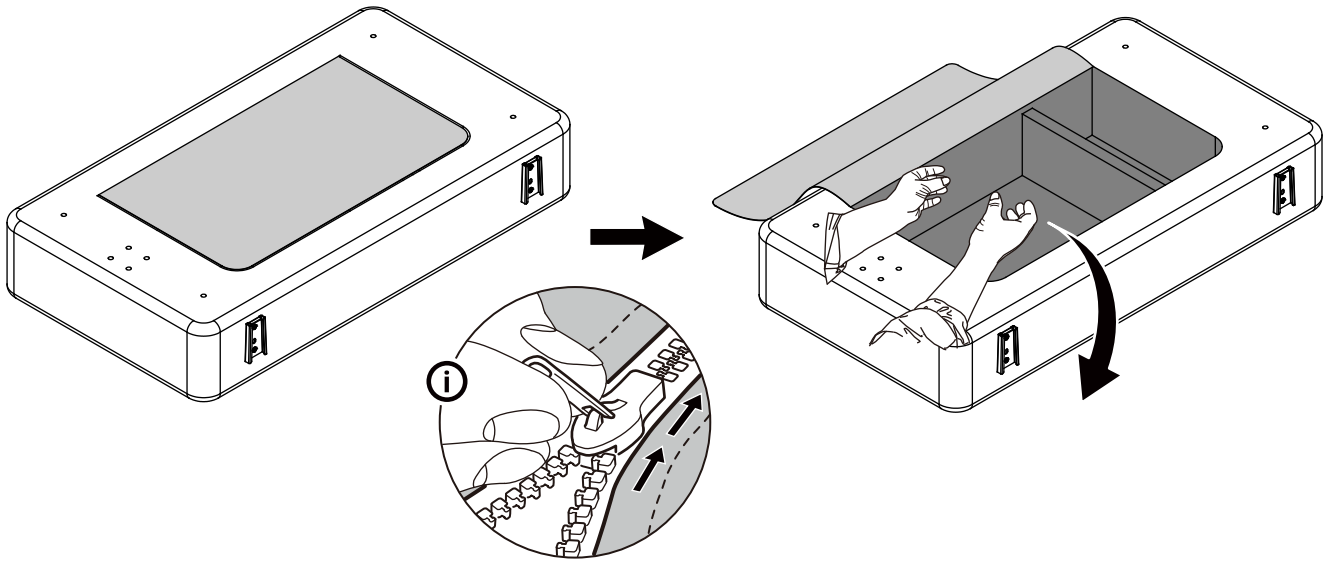

2

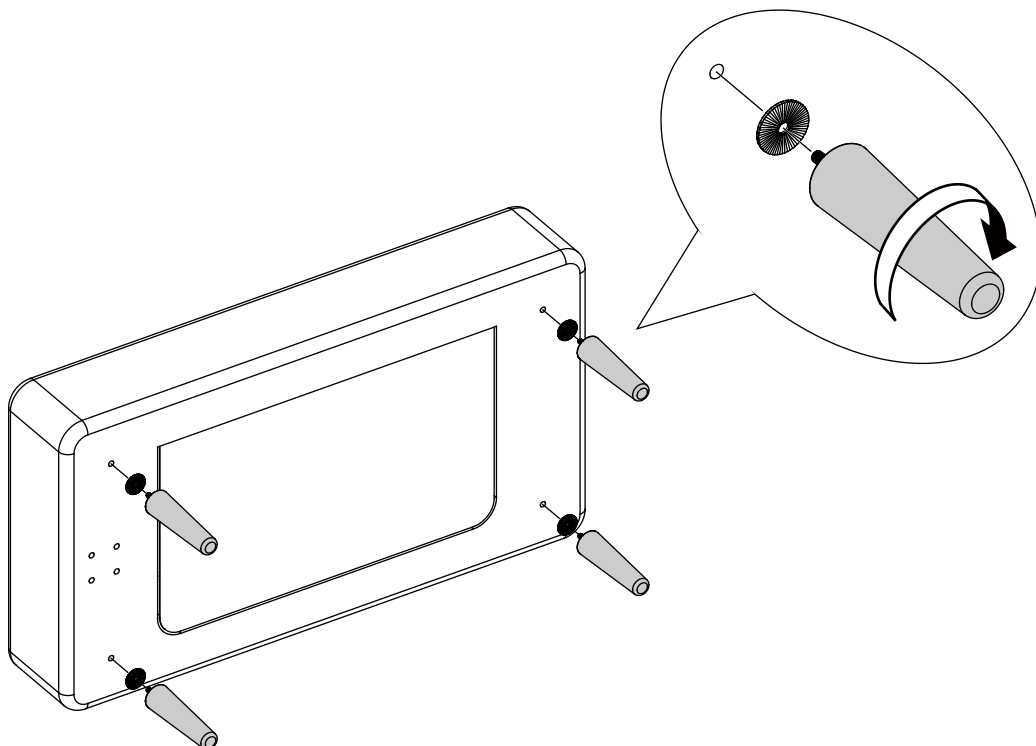

3

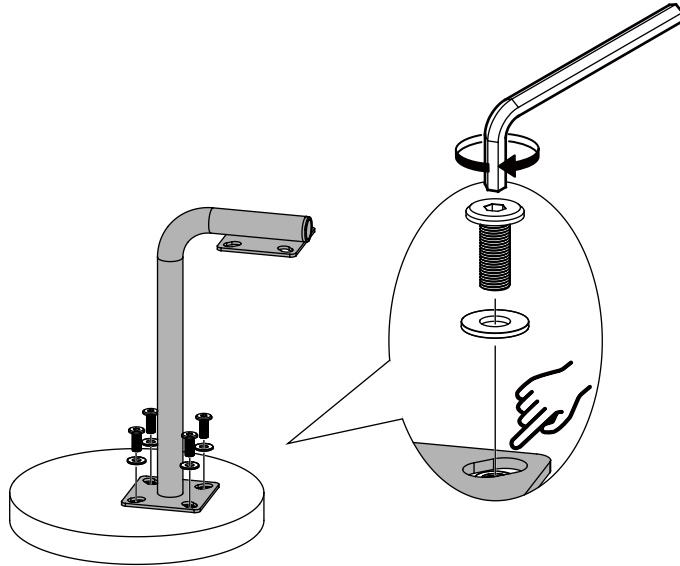
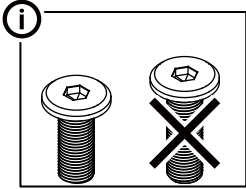

4

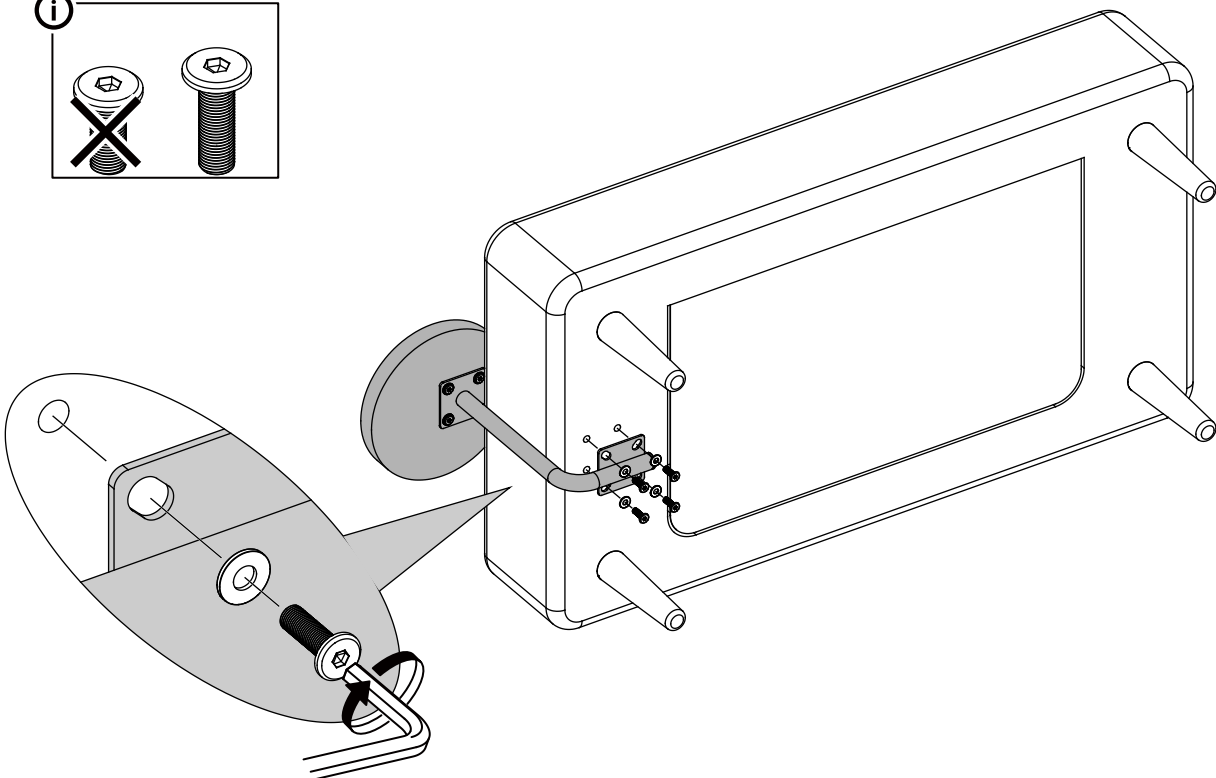
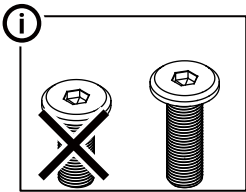

5

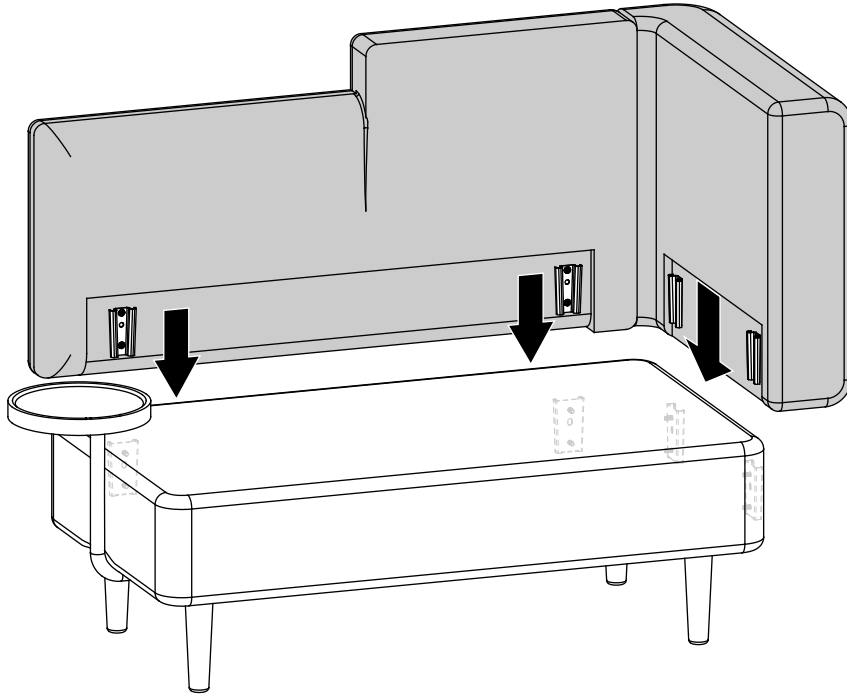

6

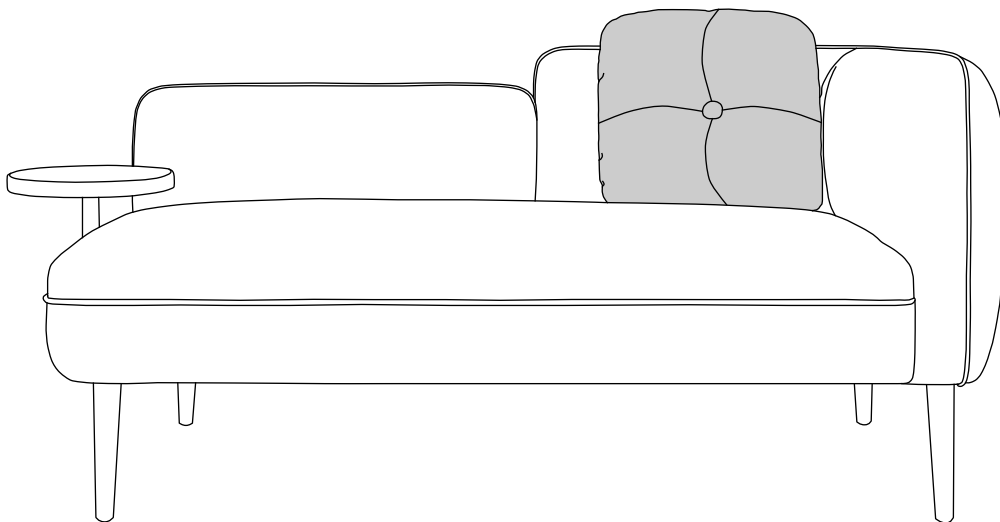

LINSY

Dear Valued Customer,

Thank you for bringing LINSY into your life, where our mission is to "Make Life Better". Your happiness and satisfaction are at the heart of what we do. If our products have brightened your day, we're thrilled and eager to share that light further.

Encountering an issue? We're here to help swiftly and effectively. Here's how you can reach us:

Get in Touch

Email us at Support@linsy.com

Share Details

Provide your order number and a photo of the issue, along with a brief description.

Await Solutions

Our team will quickly review and propose the right after-sales solution to make things right.

Your feedback propels us forward.
We're committed to ensuring your LINSY experience is always positive.

Warmest thanks,
The LINSY Team