

DW 25502 SERIES

14 Place settings
Slim panel front control screen



Main Features

- 5 programs
- 3 wash temperatures
- Brushless DC™ motor
- Condensing drying system
- 48 dBA wash noise level
- Program follow-up display
- Time delay up to 1-24 hrs.
- Auto tablet detergent function
- 1/2 load function
- Sanitize function
- Extra Rinse function
- Rapid Clean function
- 3 way euro filtering system
- smartFIT™ front adjustable rear feet
- Interior highloop with air gap
- Power plug

Interior design

- All stainless steel tank
- Three spray arms (lower, upper and ceiling)

Base rack loading system

- Unloaded adjustable upper rack
- 2 adjustable mug shelves
- Sliding cutlery basket
- Fixed lower rack tines

Color

- DW 25502 W: White
- DW 25502 B: Black
- DW 25502 SS: Stainless steel



FEATURES



14 Place settings

Blomberg dishwashers can perfectly clean dishes upto 14 place settings without leaving any piece of cutlery out.



Rapid Clean

The dishwasher increases the washing temperature and adjust the water pressure to provide up to 2 times faster cleaning performance.



Auto Tablet

Sensors detects rinse aid and automaticly sets drying cycle duration. This provides the best drying results without any concern.



Brushless DC™ motor

Variable speed circulation motor allows to use optimum necessary amount of water and energy. Due to magnetic design the motor has no persistent low frequency sound, and creates less vibration.



Digital display

The electronic display is a quick and easy way to select your programs. Additionally, models with top control panel with numerical display offer a noise level adjustable "end of cycle audible signal". Hidden control panel prevents your children from changing programs and playing with your dishwasher.



Double motion float system

All Blomberg dishwashers have a double motion float system (DMFS) that provides maximum security against water damage and a bottom tray to prevent flooding.

Blomberg®

seit 1883

DW 25502 SERIES

14 Place settings Slim panel front control screen

CONTROLS	
Control Type	Electronic
Position	Front
MAIN FEATURES	
Loading Capacity (place settings)	14
Tub material	Stainless Steel
Inner door material	Stainless Steel
Water Softener	-
DMFS overflow protection	✓
5 level wash with 3rd spray arm	✓
Delay timer up to 1-24 hrs	✓
3 way euro filter	✓
Drying	Condensation
Turbidity sensor	✓
Silence level, dBA	48 dBA
Auto Tablet function	✓
1/2 Load function	✓
Sanitize function	✓
Extra Rinse function	✓
Extra Drying	-
Rapid Clean function	✓
SmartPIN™ joint	-
Interior high loop with airgap	✓
Power Plug	✓
PROGRAMS	
Number of programs	5
ProCare	✓
Pots and pans plus (167°F rinse temp)	✓
Regular wash (142°F-145°F rinse temp)	✓
DailyWash	✓
China/crystal (149°F rinse temp)	-
Quick wash (131°F rinse temp)	✓
Rinse & Hold	✓
DISPLAY	
Program sequence	✓ / Screen
Rinse aid indicator	Electronic
Rinse aid indicator display	✓
Salt indicator display	-
Light Indicator on Floor	-
RACK SYSTEM	
smartFOLD lower rack folding tines	-
Lower rack embossed stainless handle	-
Cutlery basket	Sliding
Upper rack (inset shelves)	2
smartFOLD, upper rack folding tines	-
FlexiRack, adjustable upper rack	Unloaded
Nylon coated racks	✓
DIMENSIONS	
Packed (HxWxD)	in 34 3/8 x 25 3/16 x 26
	cm 85.9 x 64.4 x 66.1
Packed Weight	(lb/kg) 93/42
Unpacked (HxWxD)	in 32 1/5 x 23 9/16 x 22 2/5
	cm 82 x 59.8 x 57
Unpacked Weight	(lb/kg) 86/39
ENVIRONMENTAL STANDARDS	
Energy Star qualified	✓
Energy consumption, kWh/year	255
Water consumption, gal/cycle	3.5 - 5.0
RoHS* compliant	✓

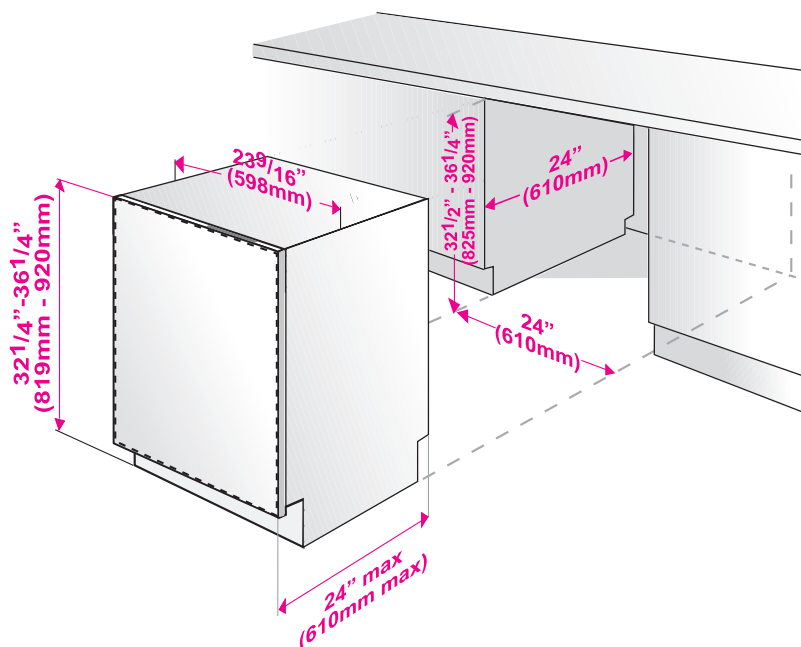

* Lead-free