

Lazy Lifter Assembly Instructions

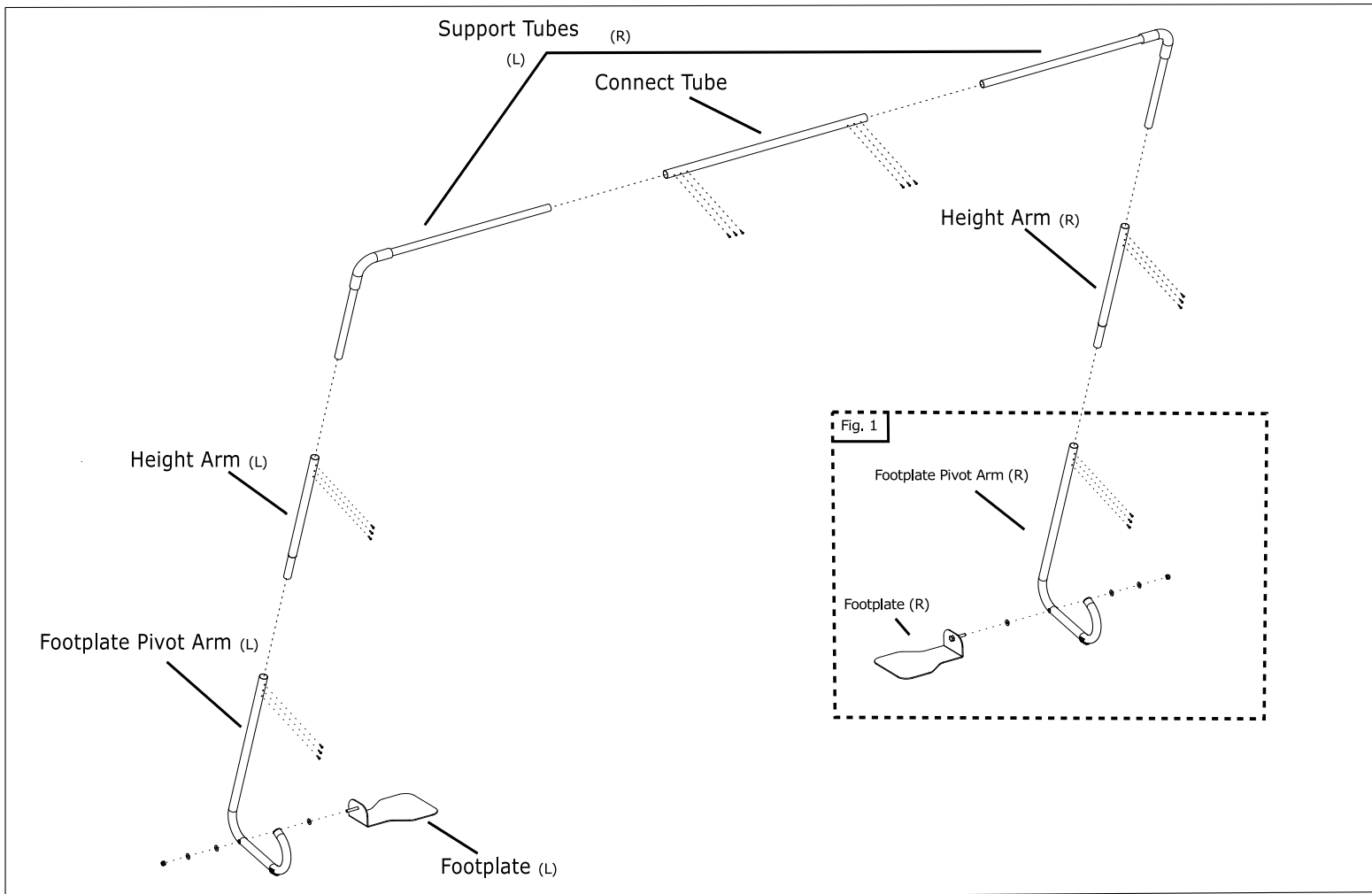

- Components:** (2) Footplates with welded bolts [(1) right footplate (1) left footplate]
(2) Footplate Pivot Arms with "stop"
(2) Height Arms (swedged)
(2) Support Arms (with foam elbows)
(1) Connect tube (38")
(1) Hardware kit [(18)Steel Tek screws]

- *Each Footplate bolt is pre-assembled with (2) Nylon Washers (1) Metal washer (1) Locking Nut*

Step 1: Make sure your spa is empty of water. Your spa cover should be closed on top of your spa. Make sure all 4 corners are in their proper position.

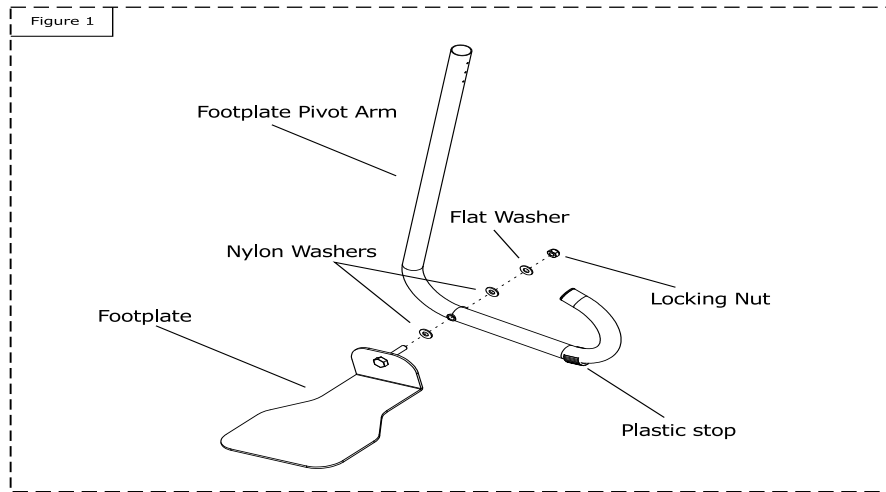

Step 2: Assemble your footplate onto your Footplate Pivot Arm (see Figure 1). Make sure you assemble (2) Footplates (1 Left and 1 right) They should be mirror images of each other. To assemble, unscrew the locking nut, metal washer, and only 1 nylon washer from the footplate bolt. Place the footplate bolt through the footplate pivot arm. Then place the Nylon washer on the bolt first, and then the metal washer. Screw on the locking nut with wrench. Do not over tighten the locking nut. The pivot arm should move freely from the footplate pivot arm.

Step 3: Assemble the other footplate onto your Footplate Pivot arm. Assemble the other footplate on the opposite side of the footplate pivot arm. This will create a left and right footplate. (See drawing on page 1)

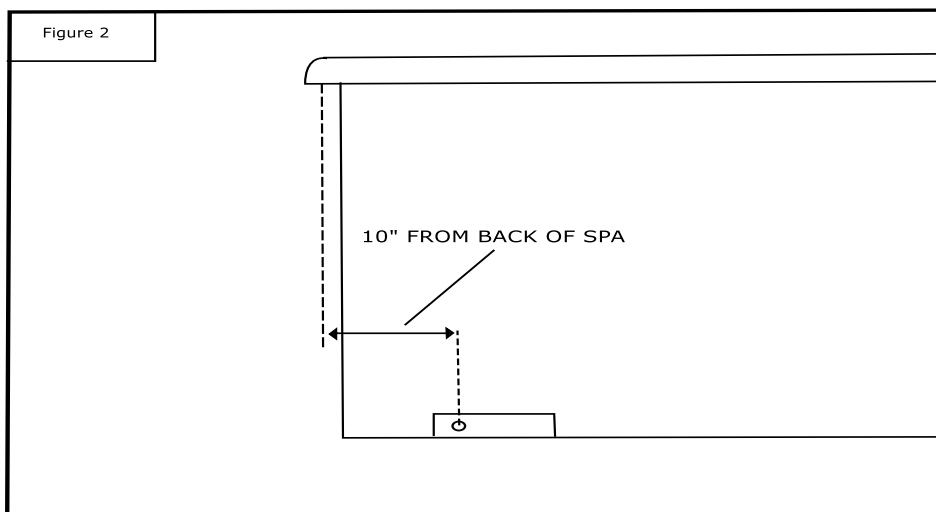

Step 4: Place the footplate under your spa cabinet.

To calculate placement of the footplate: (Use 1/2 the width of the spa) divide by 2 - the thickness of your cover)

<u>Spa Size</u>	<u>1/2 the width</u>	<u>Divide by 2</u>	<u>Thickness of cover</u>	<u>Placement of footplate</u>
6 foot spa	36 inches	18 inches	5 inches	13 inches
7 foot spa	42 inches	21 inches	5 inches	16 inches
8 foot spa	48 inches	24 inches	5 inches	19 inches

Place footplate at the calculated spot. Make sure curved pivot arm (with stop)faces the outside edge of cabinet

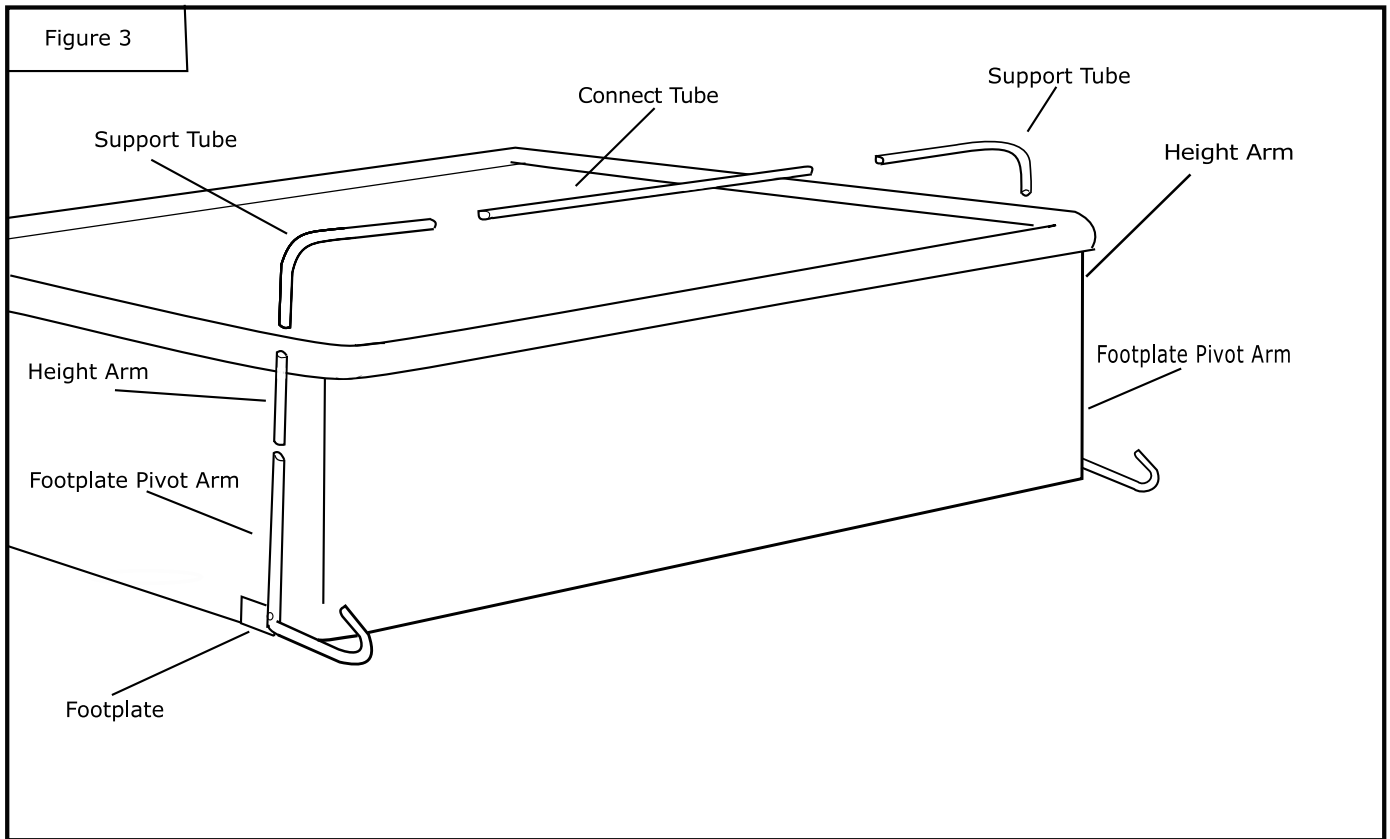

Step 5: Attach Height Arms to Footplate Pivot Arm (see Figure 3). Slide the swaged end (smaller side) of Height arm into the footplate pivot arm ****Do not attach screws at this point **** We will do this later.

****Special Note:** Depending on the **height** of the spa (smaller spas) you may need to omit the (2) height arms. The height arms are needed for larger spas.

Step 6: Attaching the Support tube (one side of the elbow is longer than the other)(**Fig. 3**) **For smaller spas;** the longer side of the Support tube will go directly into the Footplate Pivot Arm.(Omitting the height arm) and the shorter side will be on top of the cover and attached to the Connect tube.

For larger spas; the shorter side of the Support tube will attach to the height arms and the longer side will be on top of cover and attach to the Connect tube.

Step 7: Lay the Connect tube in the center of the closed spa cover. Depending on your spa size; you must adjust the (2) Support tubes and the (1) Connect tube lengths so they overlap. (per directions in step 6) The Support tubes must be **1/2"** away from the edge of your spa for clearance. Otherwise the lifter may rub on your cabinet. (**Fig. 3**)

****Special Note:**The Support tubes and Connect tube should be rotated so the pre-drilled holes and screws face away from the cover. This will prevent the screws from damaging the cover.

Step 8: Once you have all of the metal tubes adjusted to the correct height and width; you are ready to attach the screws. Enclosed are 18 self-tapping screws.

****Basic tips for using self-tapping screws**:**

- You will need to use a power drill or power impact drill
- Use steady pressure on screws (be patience as it may take time for the screw to cut through the metal tube)
- If you are unable to get the screws to penetrate the metal, mark the inside tube aligned with the predrilled tube. Then use a 1/8" metal drill bit to **pre-drill** the solid tube.

Start attaching the Footplate Pivot Arm with 3 screws and then move to the opposite side. Then work up the lifter to the next tube until all pre-drilled holes have been filled with the self-tapping screws. (see drawing on page 1)