

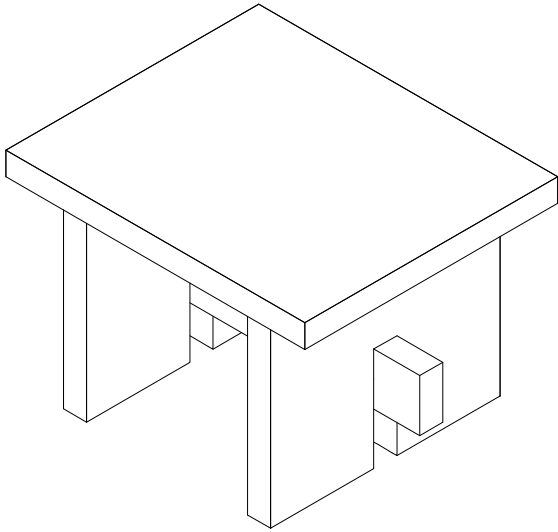

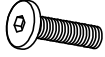

ASSEMBLY INSTRUCTION FOR END TABLE

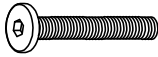

Hardware List

A		Bolt	8x35mm	12
B		Bolt	8x80mm	2
C		Flat Washer	8x19mm	14
D		Spring washer	8x19mm	14
E		Allen Key	5mm	1

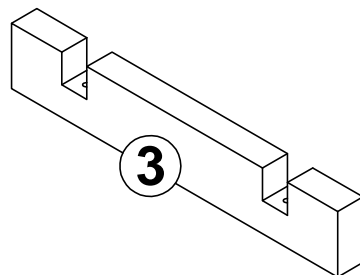
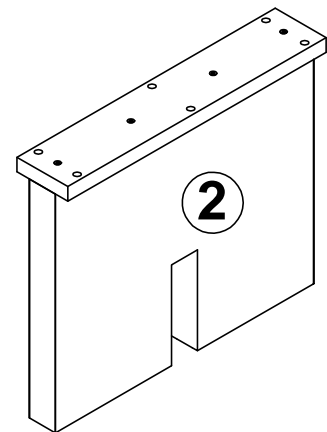
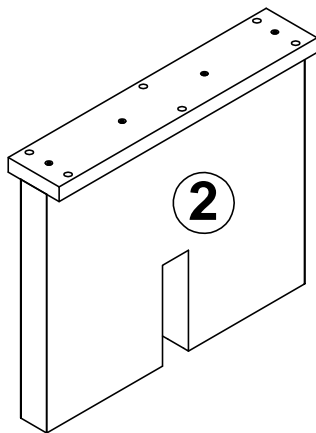
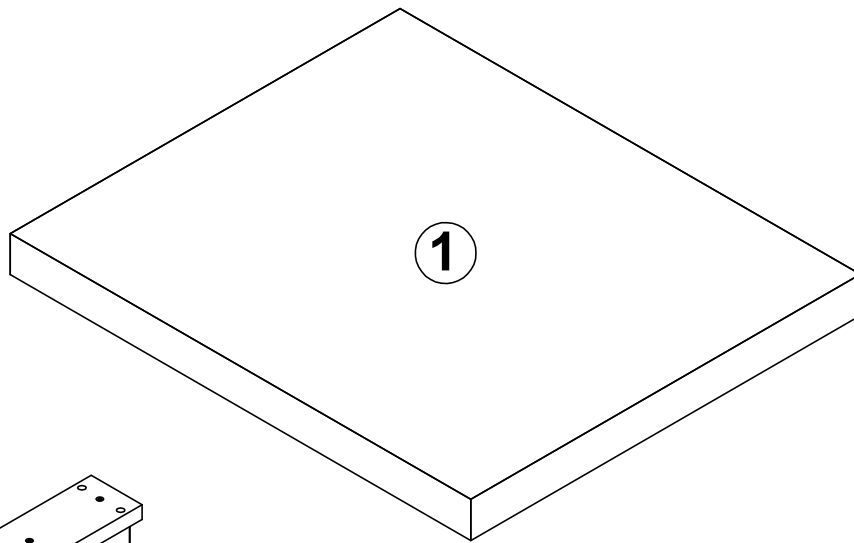

Step 1

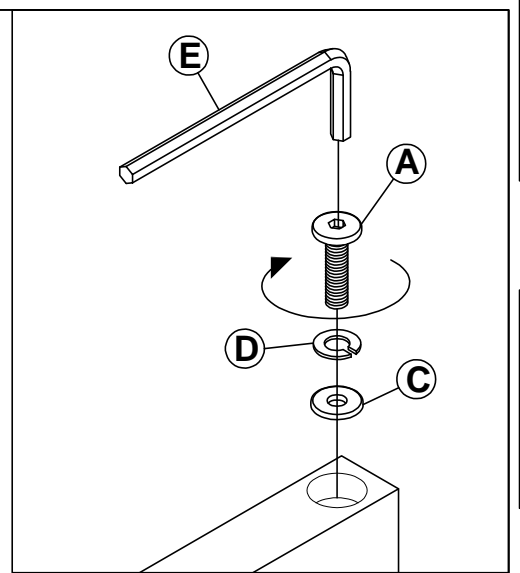
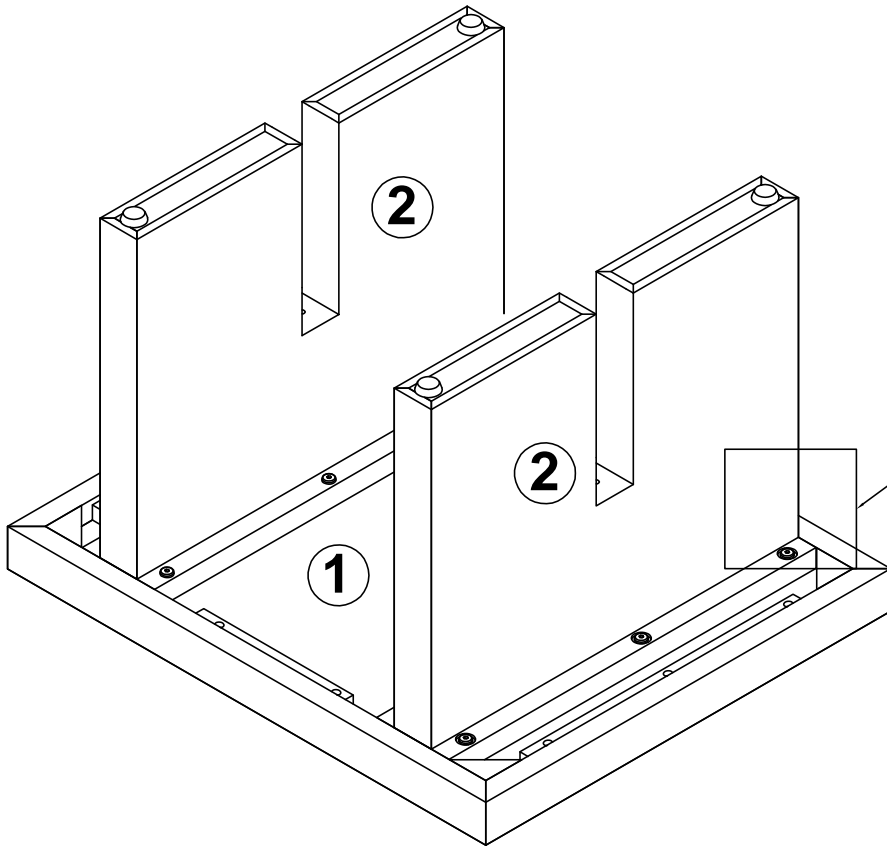

Step 2

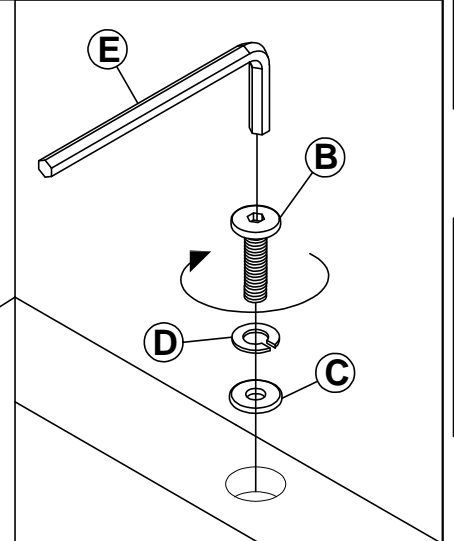
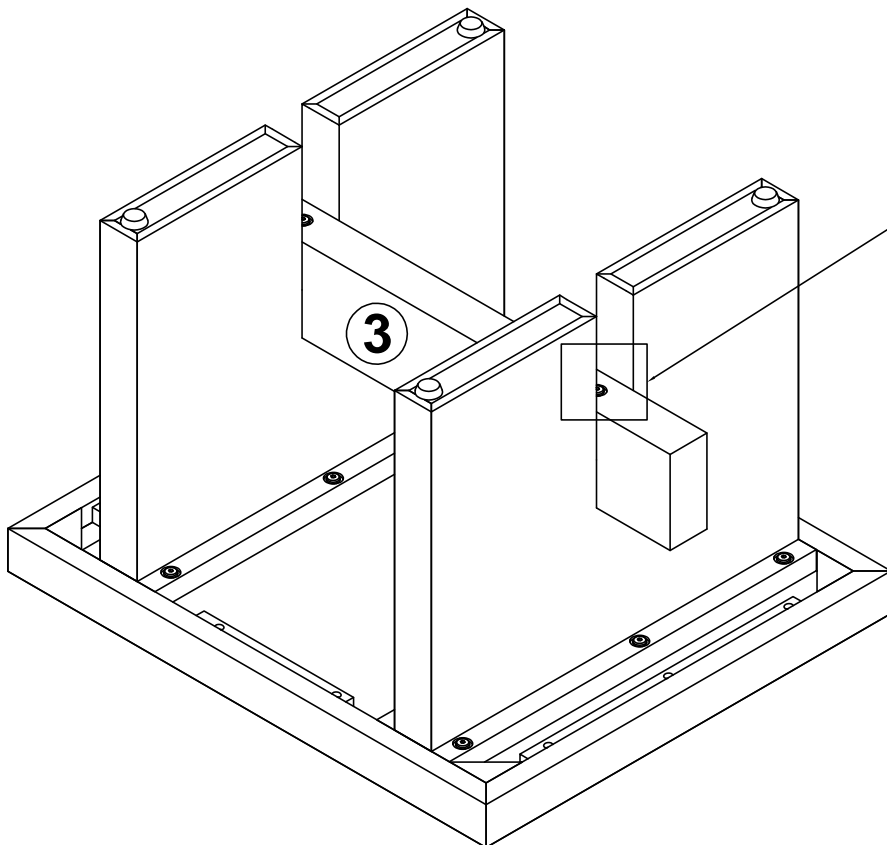

Step 3

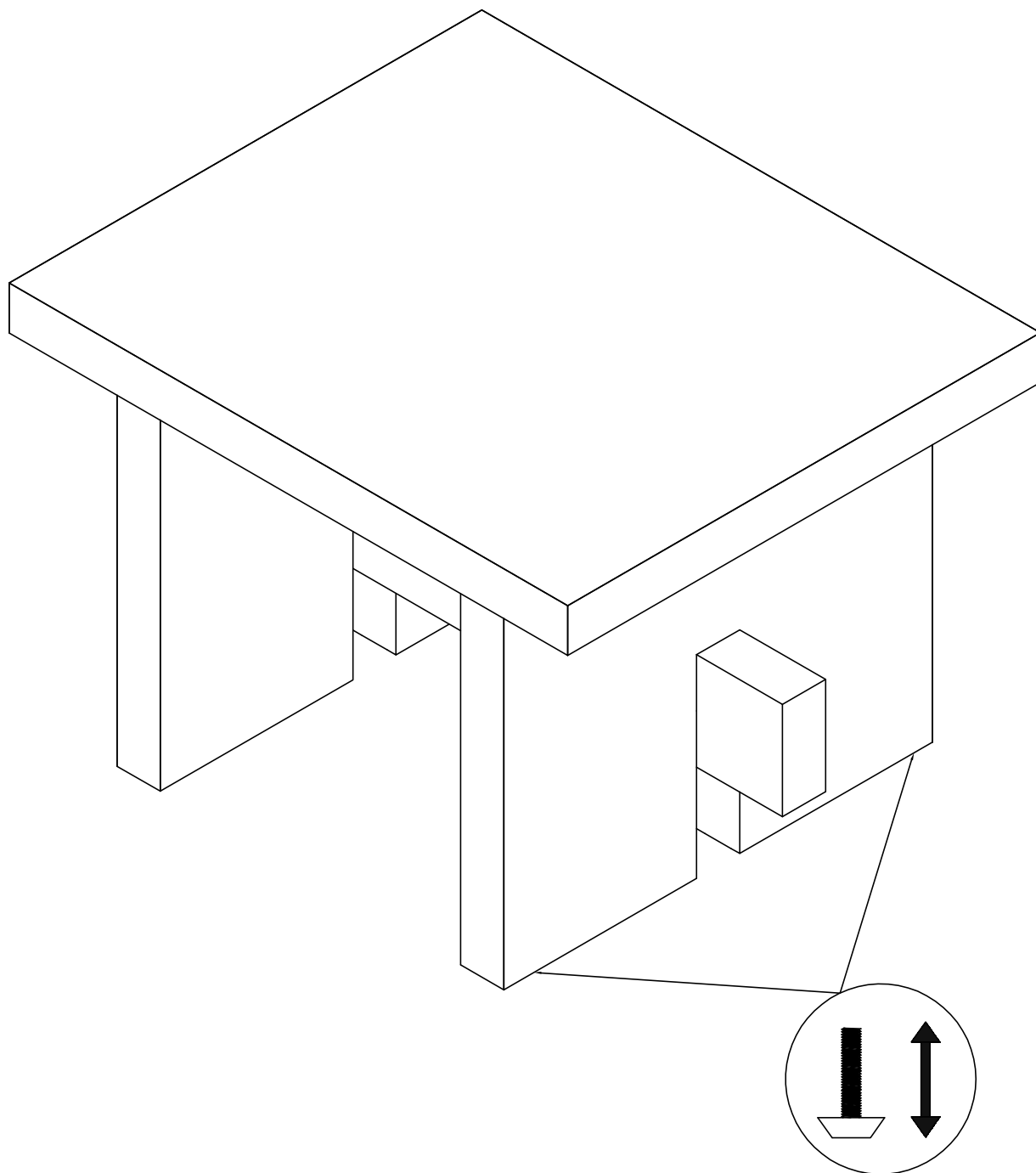

Leveler can be adjusted as necessary for the dresser balance