

# ASSEMBLY INSTRUCTIONS

ITEM NO. ARM CHAIR - WF301169

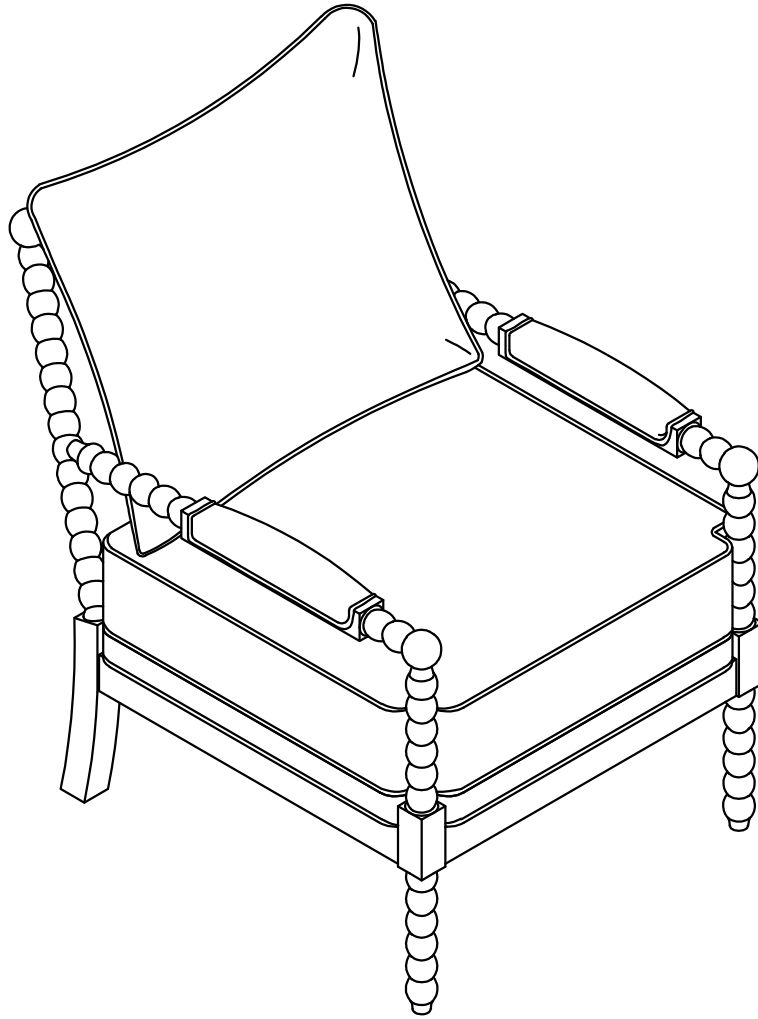





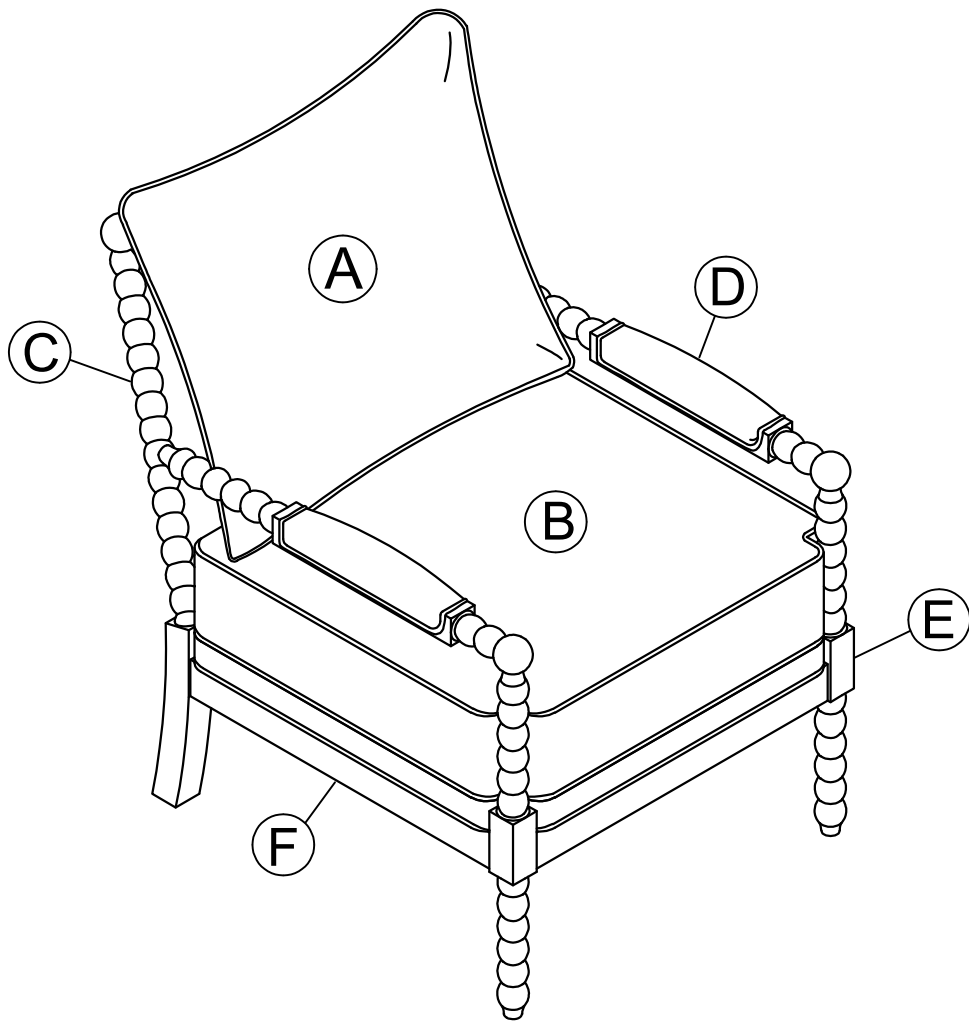

**IMPORTANT NOTE:**

- ① PLACE ALL PARTS ON A CLEAN AND SMOOTH SURFACE SUCH AS A RUG OR CARPET TO AVOID THE PARTS FROM BEING SCRATCHED.
- ② BEFORE YOU BEGIN, KINDLY FOLLOW THE ASSEMBLY INSTRUCTIONS STEP BY STEP.
- ③ DO NOT TIGHTEN ALL SCREWS AND BOLTS UNTIL THE CHAIR IS FULLY SET-UP.

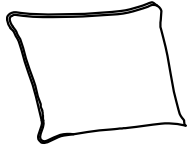
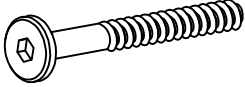
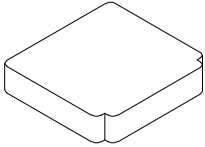
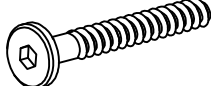
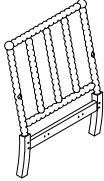
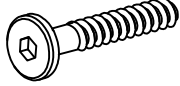
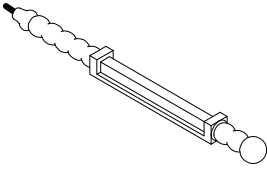

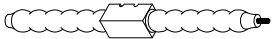
# Part List

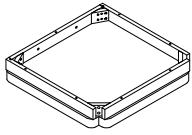
# Hardware List

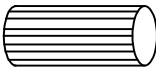
<p>(A)</p>  <p>BACK CUSHION (1 PC)</p>	<p>(1)</p>  <p>Ø 5/16" x 75mm BOLT ( 4 pcs)</p>
<p>(B)</p>  <p>SEAT CUSHION (1 PC)</p>	<p>(2)</p>  <p>Ø 5/16" x 50mm BOLT ( 4 pcs)</p>
<p>(C)</p>  <p>BACK FRAME (1 PC)</p>	<p>(3)</p>  <p>Ø 5/16" x 38mm BOLT ( 2 pcs)</p>
<p>(D)</p>  <p>ARM CHAIR (2 PCS)</p>	<p>(4)</p>  <p>Ø 5/16" x 13mm FLAT WASHER ( 10 pcs)</p>
<p>(E)</p>  <p>FRONT LEGS (2 PCS)</p>	<p>(5)</p>  <p>Ø 5/16" x 19mm LOCK WASHER ( 10 pcs)</p>
<p>(F)</p>  <p>SEAT FRAME (1 PC)</p>	<p>(6)</p>  <p>5mm ALLEN KEY ( 1 pc)</p>
	<p>(7)</p>  <p>WOODEN PEGS (2pcs)</p>

## STEP 1:

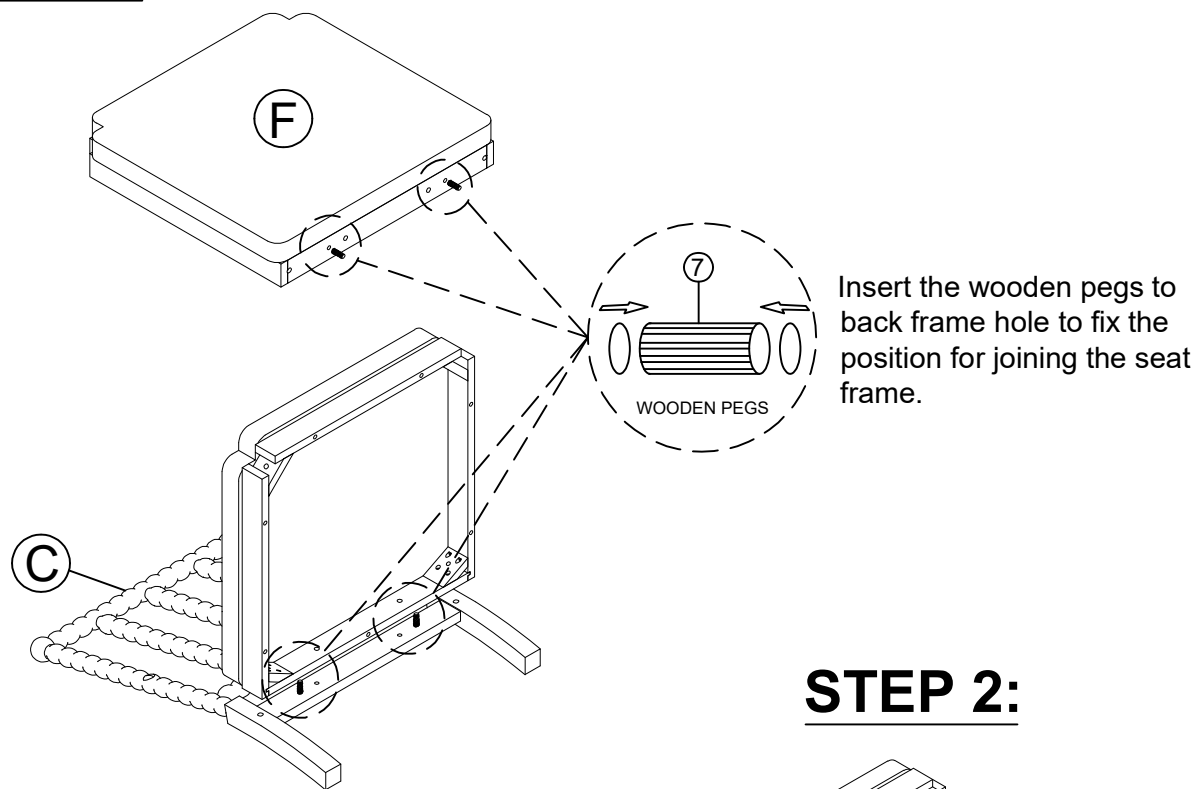

## STEP 2:

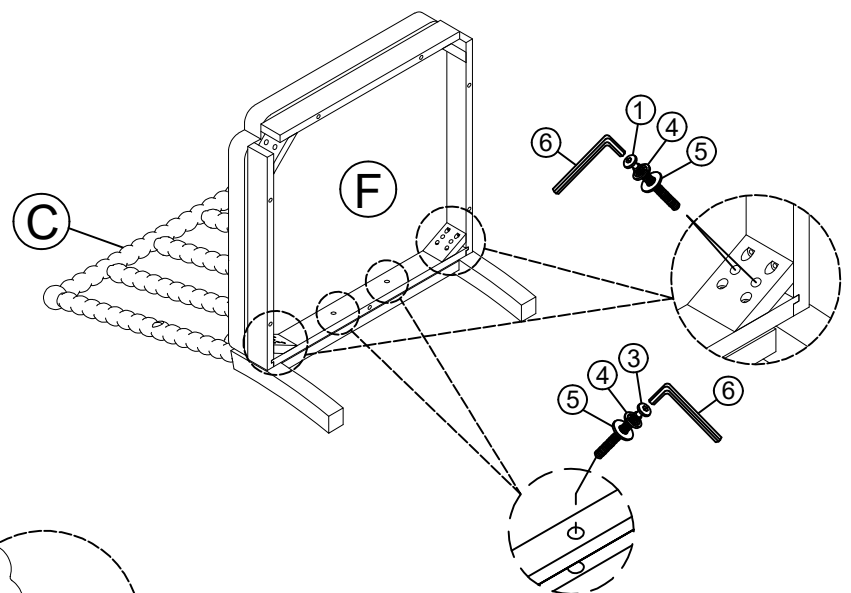

## STEP 3:

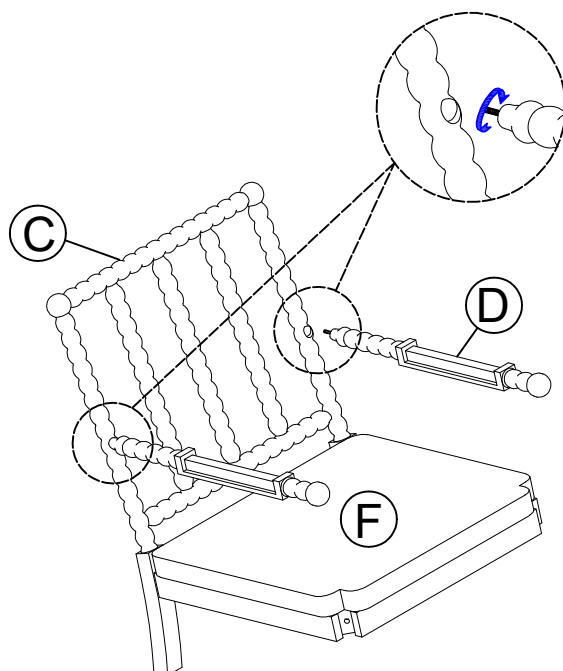

**STEP 4:**

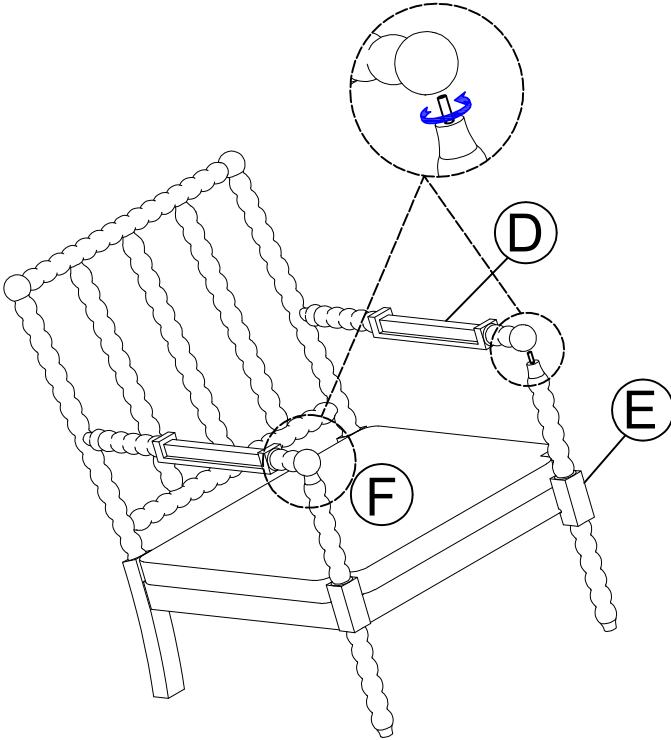

**STEP 5:**

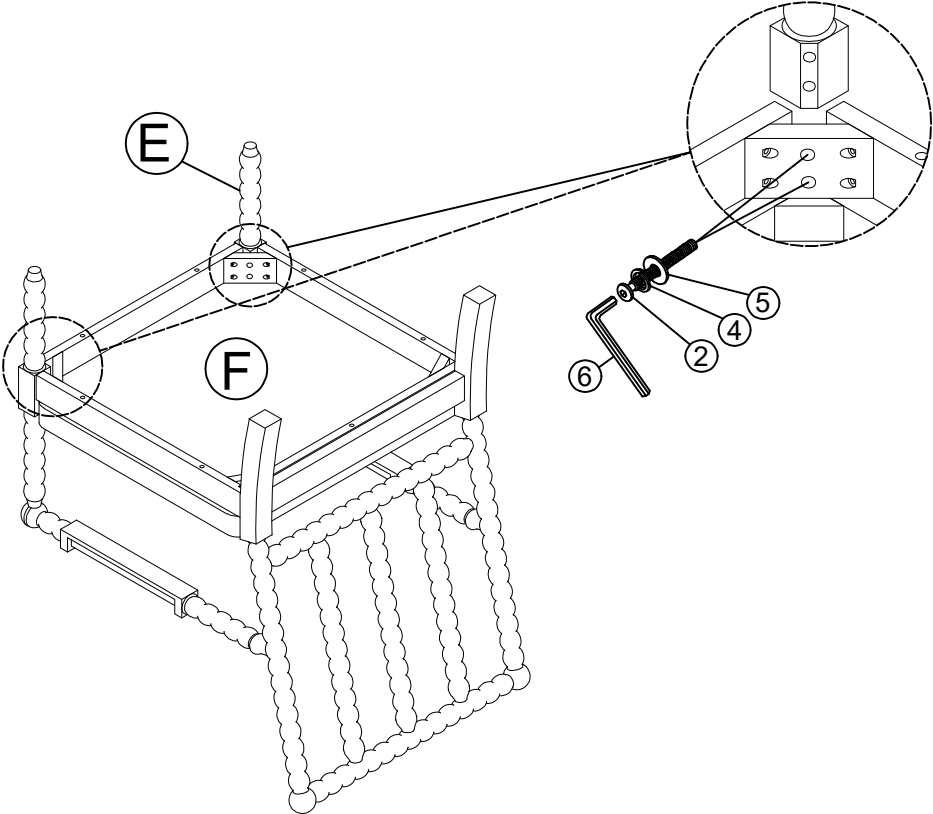

**STEP 6:**

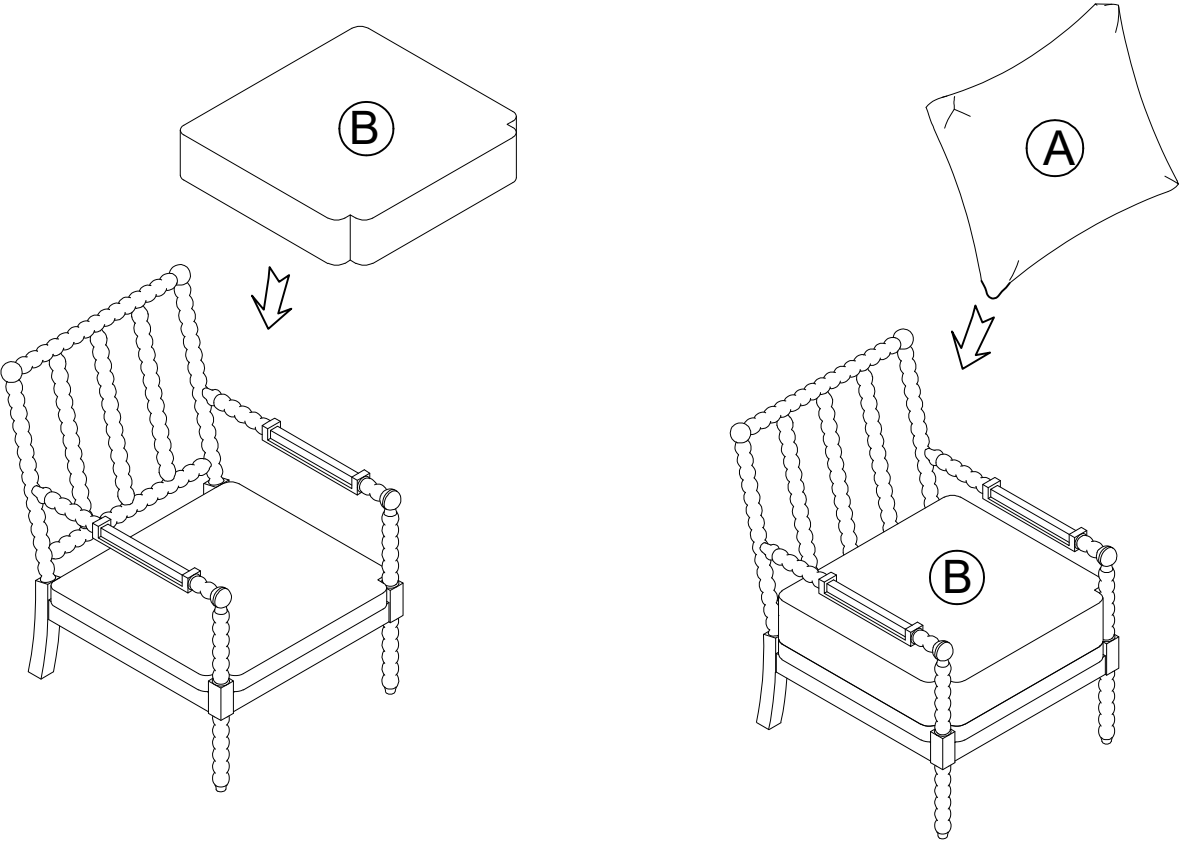

**COMPLETED :**

