

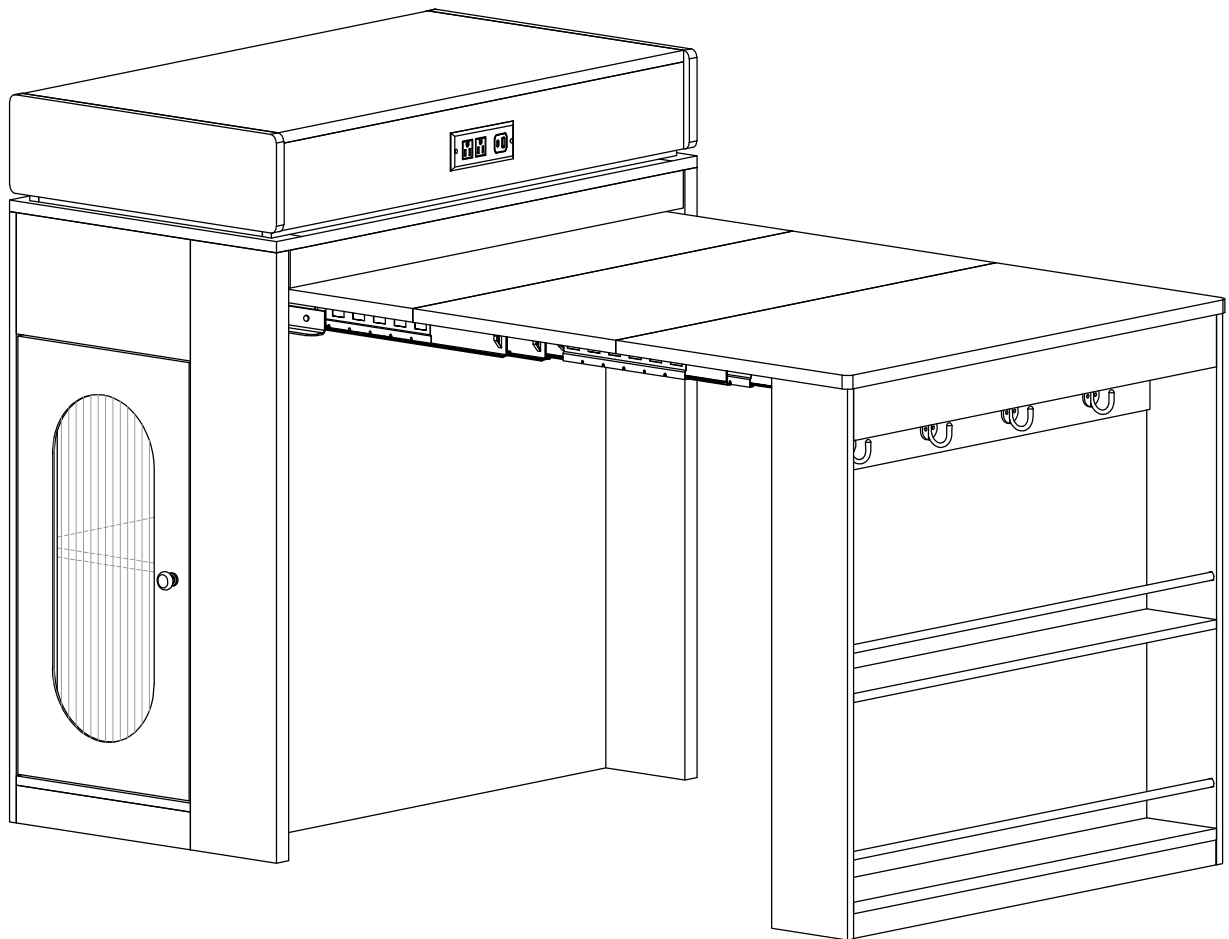

**ASSEMBLY INSTRUCTION**  
**Item : N715P396292/N715P396293**  
**EXTENDABLE TABLE**



# ASSEMBLY INSTRUCTION

## Item : N715P396292/N715P396293

### Important - Please read these instructions fully before starting assembly

- Check you have all the components and tools listed on the following pages.
  - Remove all fittings from the plastic bags and separate them into their groups.
  - Keep children and animals away from the work area, small parts could choke if swallowed.
  - Make sure you have enough space to layout the parts before starting.
  - During assembly do not stand or put weight on the product, this could cause damage.
  - Assemble the item as close to its final position (in the same room) as possible.
  - Assemble on a soft level surface to avoid damaging the unit or your floor.
  - Parts of the assembly will be easier with 2 people.
-  To reduce the likelihood of damaging your product please ensure that your power drill is set on low torque setting.

### Care and maintenance

- Only clean using a damp cloth and mild detergent, do not use bleach or abrasive cleaners.
- From time to time check that there are no loose screws on this unit.
- This product should not be discarded with household waste. Take to your local authority waste disposal centre.

### Handy Hints

- Assemble all parts and bolts loosely during assembly, only once the product is complete should you fully tighten the bolts
- Regularly check and ensure that all bolts and fittings are tightened properly.

## WARNING

**In order to help prevent overturning - please follow these instructions**

To help prevent product toppling over please follow the below steps:-

Use the anti tip strap or wall fixing method provided (if applicable)

Do not allow children to climb or hang on the furniture

Do not open more than one drawer at a time

Do not place heavy items in the top drawers

Do not place heavy items on top of the furniture, unless the furniture has been designed for this purpose

Please note that only the anti tip strap is provided.

You will need to provide wall plugs and screws applicable for your wall type

### Tools required





Screwdrivers can be converted to Phillips and Slotted.

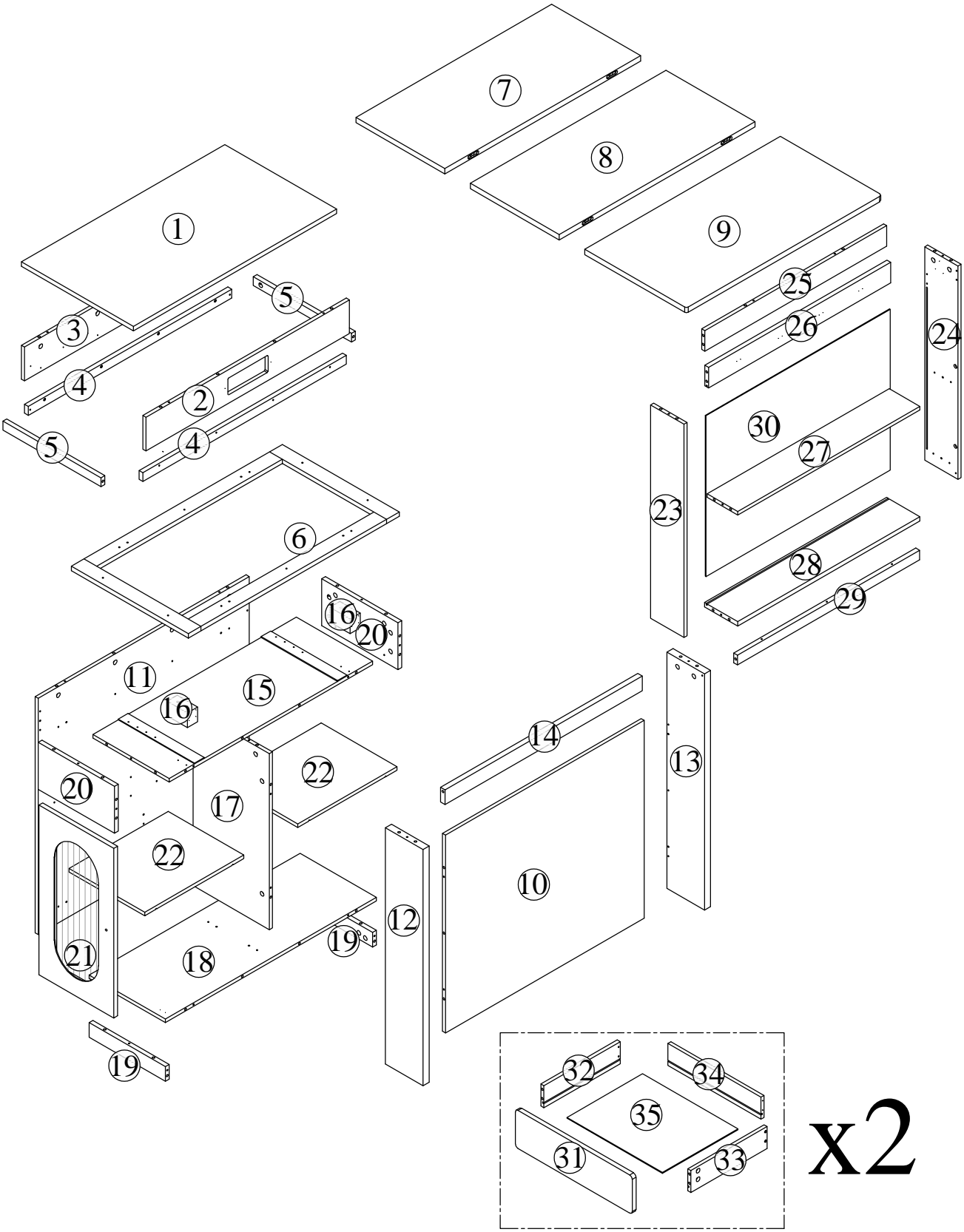

**ASSEMBLY INSTRUCTION**  
**Item : N715P396292/N715P396293**

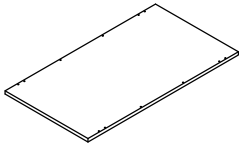
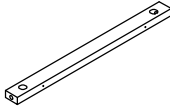
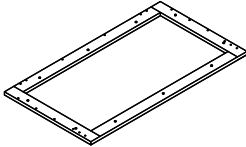
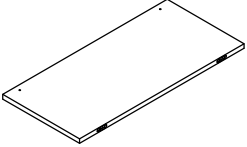
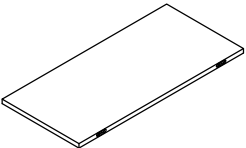
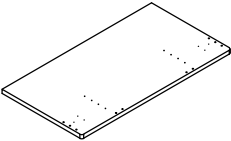
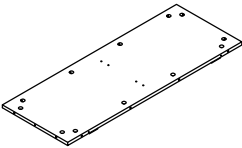

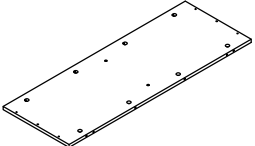
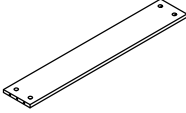
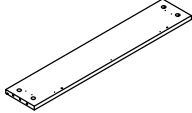



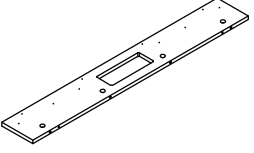
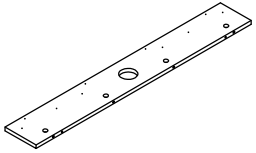
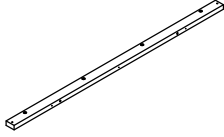
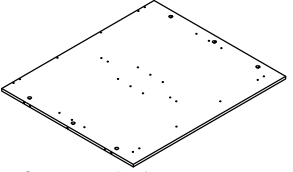
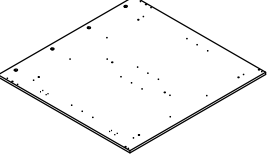
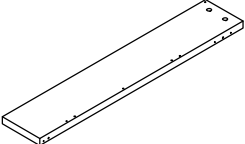
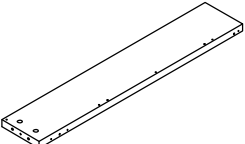
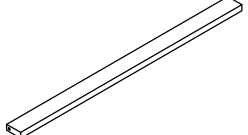
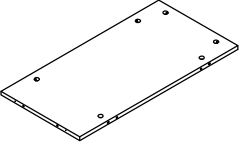
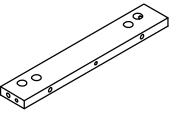
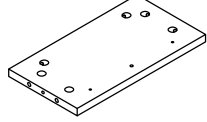
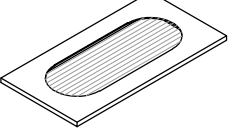
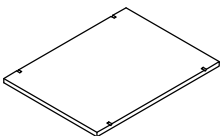
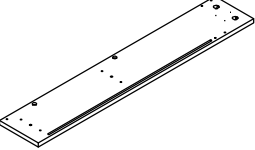
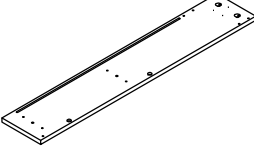
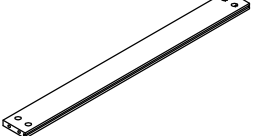
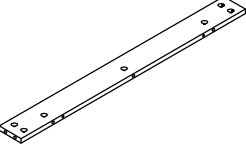
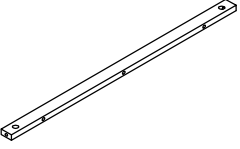
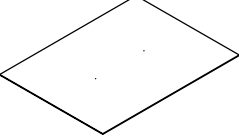
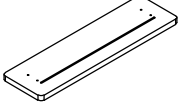
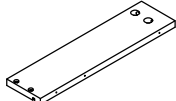
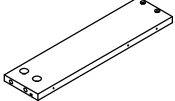

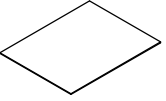
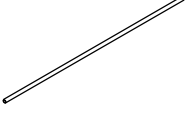



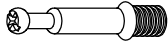

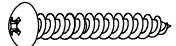

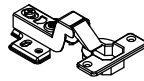

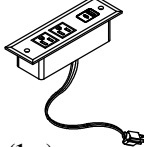

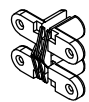

**ASSEMBLY INSTRUCTION**  
**Item : N715P396292/N715P396293**  
**PART LIST**

<b>N715P396292</b>			
<div style="border: 1px solid black; padding: 2px; display: inline-block; margin-bottom: 5px;"><b>1</b></div>  <p><b>Top panel - 1pc</b></p>	<div style="border: 1px solid black; padding: 2px; display: inline-block; margin-bottom: 5px;"><b>5</b></div>  <p><b>Up side bottom panel - 2pcs</b></p>	<div style="border: 1px solid black; padding: 2px; display: inline-block; margin-bottom: 5px;"><b>6</b></div>  <p><b>Middle frame - 1pc</b></p>	<div style="border: 1px solid black; padding: 2px; display: inline-block; margin-bottom: 5px;"><b>7</b></div>  <p><b>Top panel - 1pc</b></p>
<div style="border: 1px solid black; padding: 2px; display: inline-block; margin-bottom: 5px;"><b>8</b></div>  <p><b>Top panel - 1pc</b></p>	<div style="border: 1px solid black; padding: 2px; display: inline-block; margin-bottom: 5px;"><b>9</b></div>  <p><b>Top panel - 1pc</b></p>	<div style="border: 1px solid black; padding: 2px; display: inline-block; margin-bottom: 5px;"><b>15</b></div>  <p><b>Middle panel - 1pc</b></p>	<div style="border: 1px solid black; padding: 2px; display: inline-block; margin-bottom: 5px;"><b>16</b></div>  <p><b>Little piece of wood - 2pcs</b></p>
<div style="border: 1px solid black; padding: 2px; display: inline-block; margin-bottom: 5px;"><b>18</b></div>  <p><b>Bottom panel - 1pc</b></p>	<div style="border: 1px solid black; padding: 2px; display: inline-block; margin-bottom: 5px;"><b>27</b></div>  <p><b>Middle panel of the activity rack - 1pc</b></p>	<div style="border: 1px solid black; padding: 2px; display: inline-block; margin-bottom: 5px;"><b>28</b></div>  <p><b>Bottom panel of the activity rack - 1pc</b></p>	

**ASSEMBLY INSTRUCTION**  
**Item : N715P396292/N715P396293**  
**PART LIST**

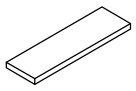
<b>N715P396293</b>			
<b>2</b>  Up front panel - 1pc	<b>3</b>  Up back panel - 1pc	<b>4</b>  Up front and back bottom rail - 2pcs	<b>10</b>  Lower front panel - 1pc
<b>11</b>  Lower back panel - 1pc	<b>12</b>  Left side panel - 1pc	<b>13</b>  Right side panel - 1pc	<b>14</b>  Middle rail - 1pc
<b>17</b>  Neutral plate - 1pc	<b>19</b>  Rail - 2pcs	<b>20</b>  Side panel - 2pcs	<b>21</b>  Door - 1pc
<b>22</b>  Adjustable shelf - 2pcs	<b>23</b>  Left plate of the activity rack - 1pc	<b>24</b>  Right plate of the activity rack - 1pc	<b>25</b>  Up front rail - 1pc
<b>26</b>  Up back rail - 1pc	<b>29</b>  Lower front rail - 1pc	<b>30</b>  Back panel - 1pc	<b>31</b>  Drawer front panel - 2pcs
<b>32</b>  Drawer left side panel - 2pcs	<b>33</b>  Drawer right side panel - 2pcs	<b>34</b>  Drawer back panel - 2pcs	<b>35</b>  Drawer bottom panel - 2pcs
<b>Z</b>  Steel pipe - 2pcs			

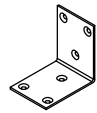
**ASSEMBLY INSTRUCTION**  
**Item : N715P396292/N715P396293**  
**HARDWARE LIST**

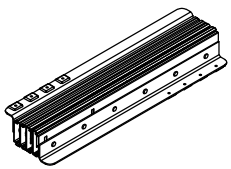
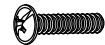
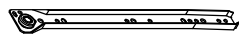
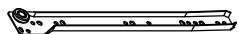
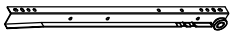
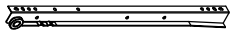
<b>N715P396293</b>			
<p><b>A</b></p> <div style="text-align: center;">             Ø6.5*35mm  <b>Minifix (104+3pcs)</b> </div>	<p><b>B</b></p> <div style="text-align: center;">             Ø15*9mm  <b>Minifix cap (104+3pcs)</b> </div>	<p><b>C</b></p> <div style="text-align: center;">             Ø6*30mm  <b>Wood dowel (54+3pcs)</b> </div>	<p><b>D</b></p> <div style="text-align: center;">             Ø4*35mm  <b>Wood screw (27+2pcs)</b> </div>
<p><b>E</b></p> <div style="text-align: center;">             Ø4*25mm  <b>Wood screw (8+1pcs)</b> </div>	<p><b>F</b></p> <div style="text-align: center;">   <b>Soft close hinges (2pcs)</b> </div>	<p><b>G</b></p> <div style="text-align: center;">             Ø4*12mm  <b>Wood screw (36+2pcs)</b> </div>	<p><b>H</b></p> <div style="text-align: center;">   <b>Insert Row (1pc)</b> </div>
<p><b>I</b></p> <div style="text-align: center;">   <b>Locating piece (2pcs)</b> </div>	<p><b>J</b></p> <div style="text-align: center;">             Ø3*12mm  <b>Wood screw (38+2pcs)</b> </div>	<p><b>K</b></p> <div style="text-align: center;">   <b>Hinges (4pcs)</b> </div>	<p><b>L</b></p> <div style="text-align: center;">             Ø4*19mm  <b>Wood screw (16+1pcs)</b> </div>
<p><b>M</b></p> <div style="text-align: center;">   <b>Handle (1pc)</b> </div>	<p><b>N</b></p> <div style="text-align: center;">   <b>Shelf support (8+1pcs)</b> </div>	<p><b>O</b></p> <div style="text-align: center;">   <b>Hook (4pcs)</b> </div>	<p><b>P</b></p> <div style="text-align: center;">             Ø5*16mm  <b>Wood screw (16+1pcs)</b> </div>
<p><b>Q</b></p> <div style="text-align: center;">   <b>Allen wrench (1pc)</b> </div>	<p><b>R</b></p> <div style="text-align: center;">   <b>Plastic baffle (1pc)</b> </div>	<p><b>S</b></p> <div style="text-align: center;">   <b>Felt pad (8+1pcs)</b> </div>	<p><b>T</b></p> <div style="text-align: center;">   <b>Caster wheels (2pcs)</b> </div>
<p><b>U</b></p> <div style="text-align: center;">   <b>Outlet cover (1pc)</b> </div>	<p><b>V</b></p> <div style="text-align: center;">   <b>L-shaped iron sheet (2pcs)</b> </div>	<p><b>W</b></p> <div style="text-align: center;">   <b>Spring bolt (2pcs)</b> </div>	<p><b>X</b></p> <div style="text-align: center;">   <b>Slide rail (2pcs)</b> </div>
<p><b>Y</b></p> <div style="text-align: center;">             M4*16mm  <b>Bolt (1pc)</b> </div>	<p><b>CL</b></p> <div style="text-align: center;">             300mm  <b>Slide rail (2pcs)</b> </div>	<p><b>CR</b></p> <div style="text-align: center;">             300mm  <b>Slide rail (2pcs)</b> </div>	<p><b>DL</b></p> <div style="text-align: center;">             300mm  <b>Slide rail (2pcs)</b> </div>
<p><b>DR</b></p> <div style="text-align: center;">             300mm  <b>Slide rail (2pcs)</b> </div>			

# ASSEMBLY INSTRUCTION

Item : N715P396292/N715P396293

## Step 1

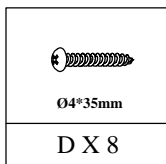
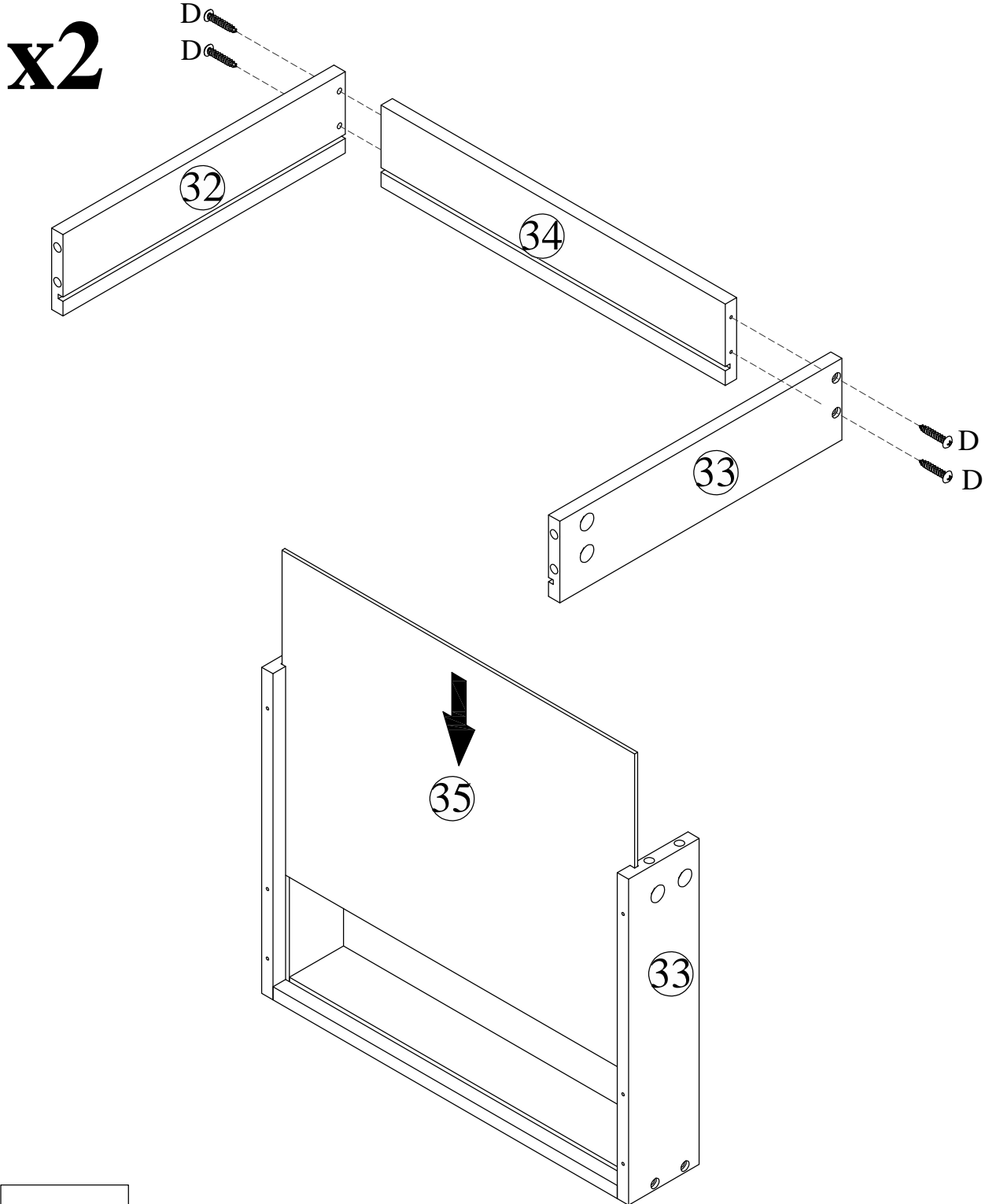



# ASSEMBLY INSTRUCTION

## Item : N715P396292/N715P396293

### Step 2

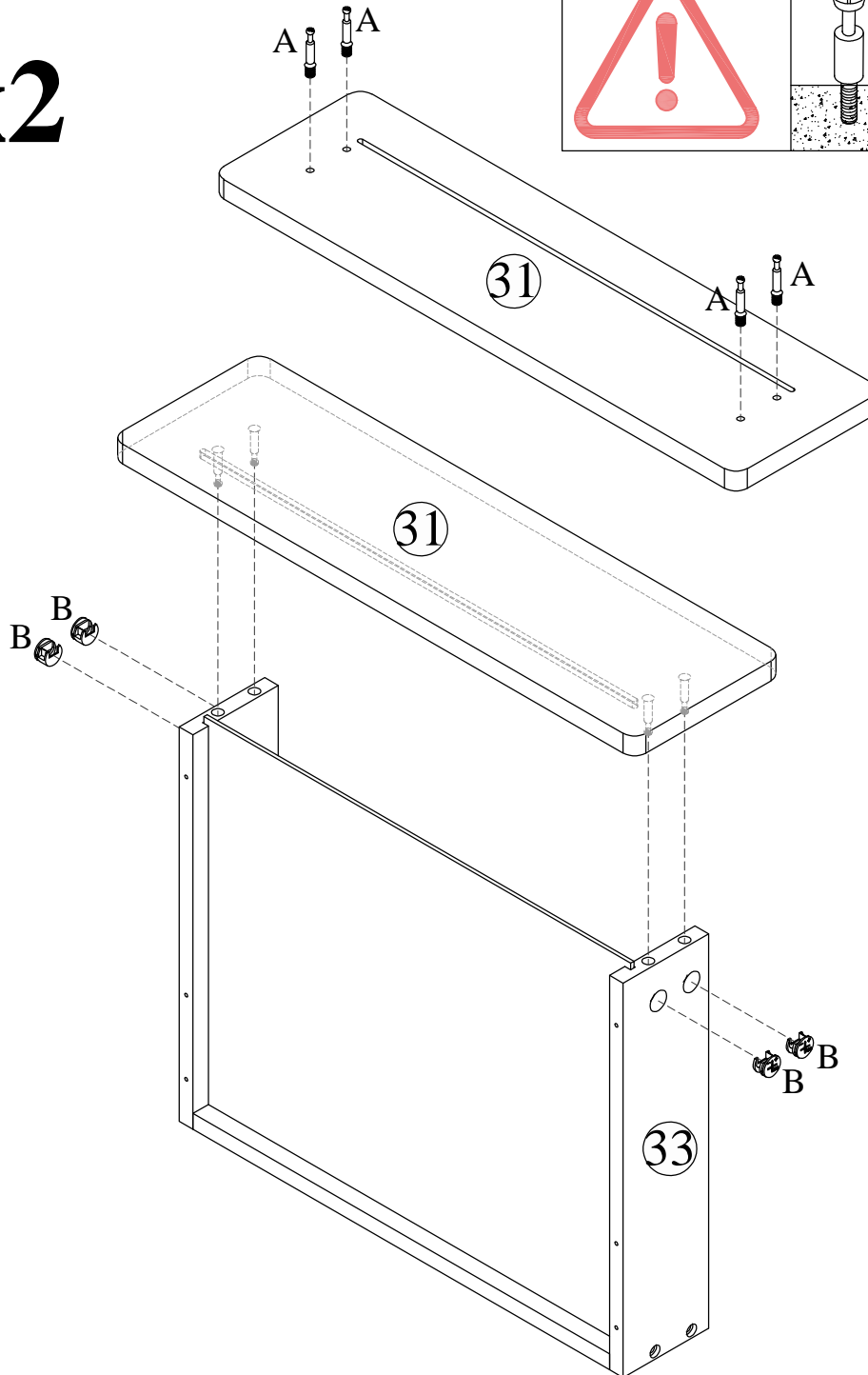
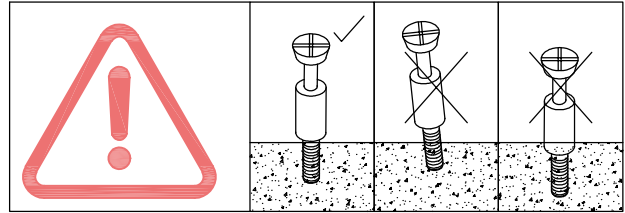
**x2**

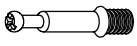

	
Ø6.5*35mm	Ø15*9mm
A X 8	B X 8

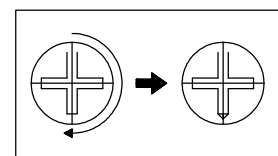

Lock Minifix cap clockwise



# ASSEMBLY INSTRUCTION

## Item : N715P396292/N715P396293

### Step 3

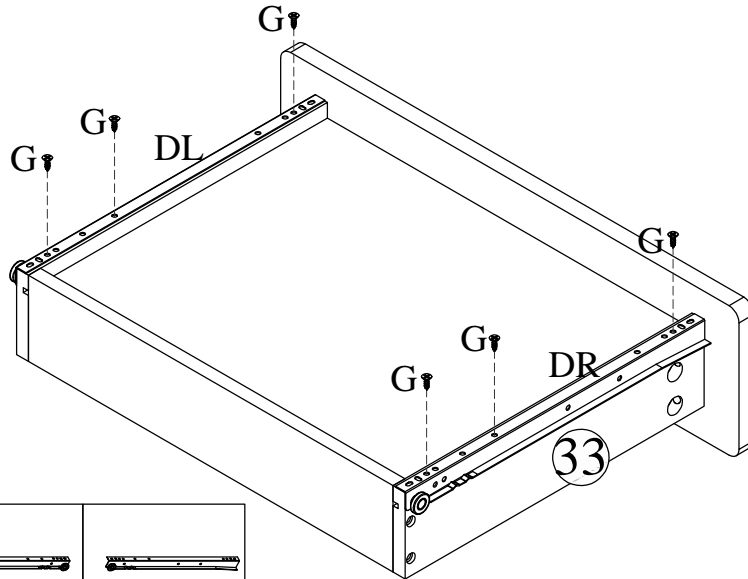



**x2**

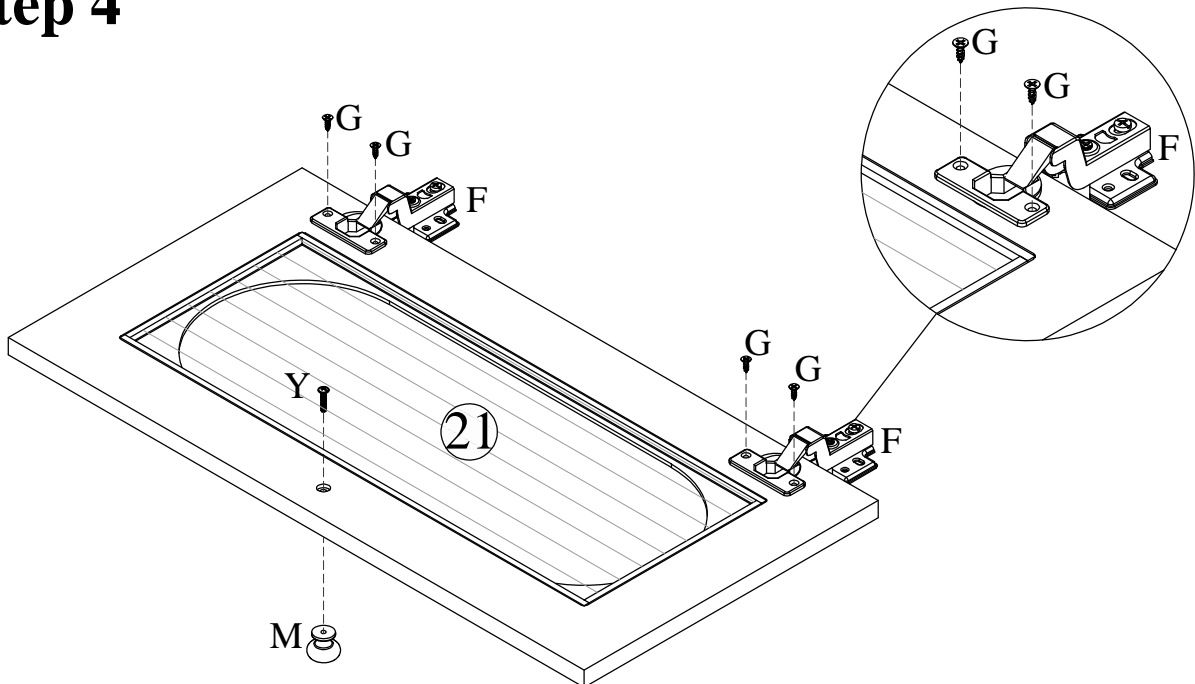

		
Ø4*12mm	300mm	300mm
G X 12	DL X 2	DR X 2

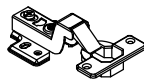
### Step 4



			
	Ø4*12mm		M4*16mm
FX 2	G X 4	MX 1	Y X 1

# ASSEMBLY INSTRUCTION

## Item : N715P396292/N715P396293

### Step 5

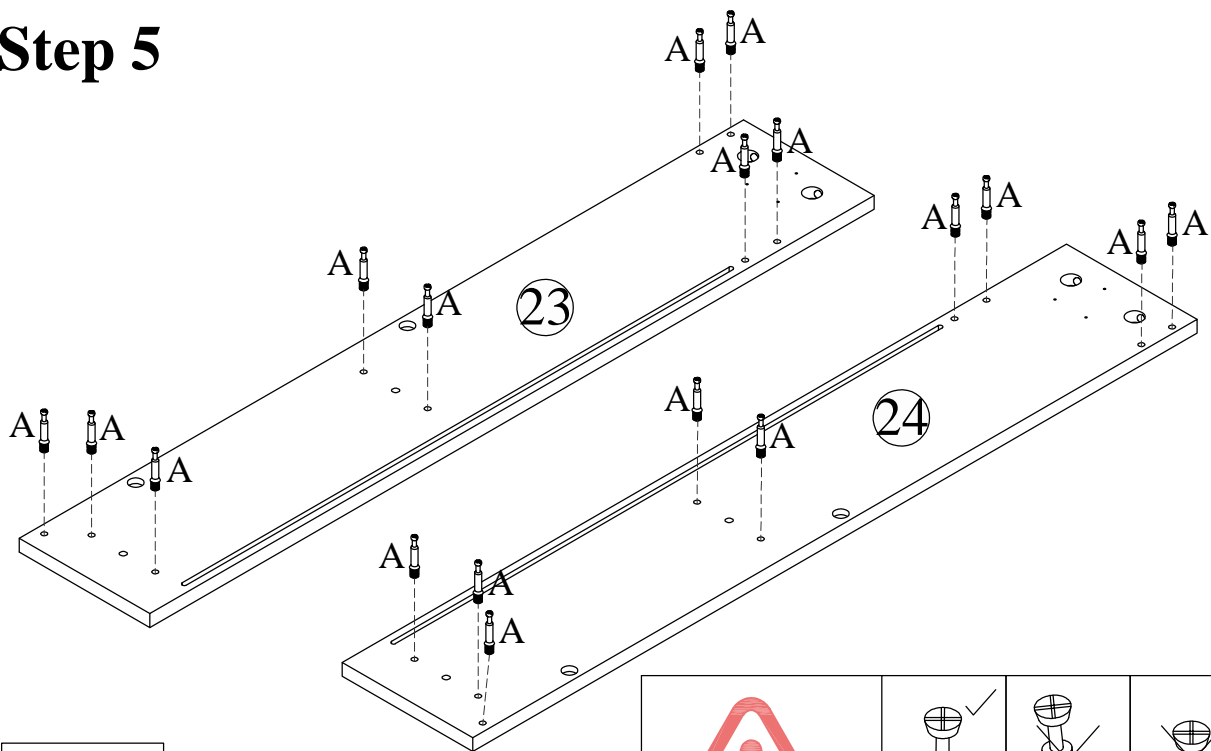

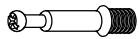

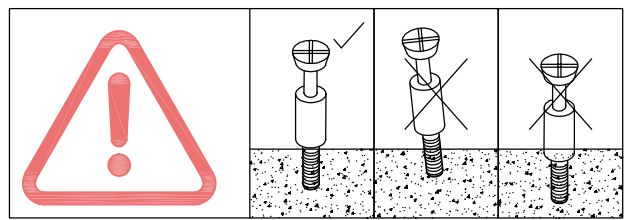

06.5*35mm
A X 18

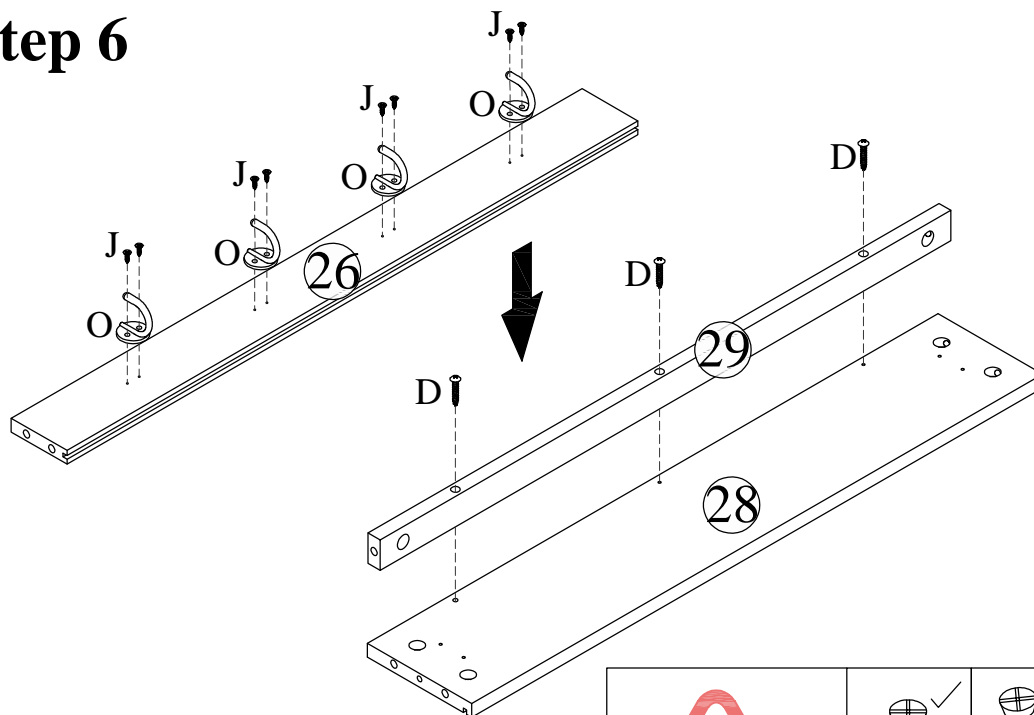

### Step 6

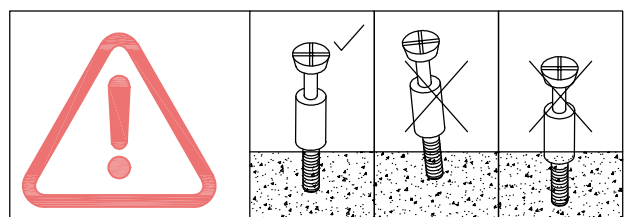

		
04*35mm	03*12mm	
D X 3	J X 8	O X 4



# ASSEMBLY INSTRUCTION

## Item : N715P396292/N715P396293

### Step 7

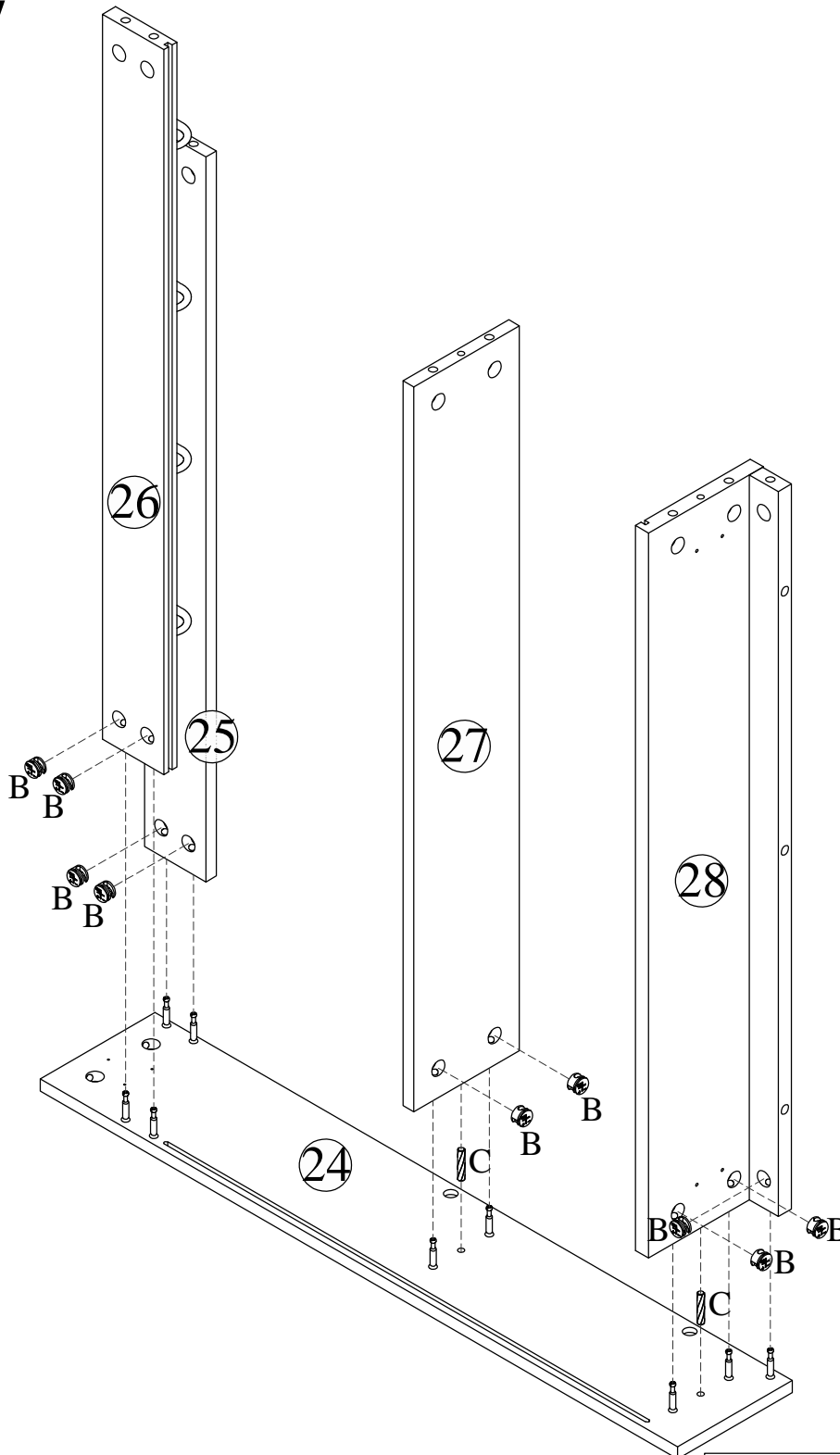

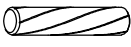
	
Ø15*9mm	Ø6*30mm
B X 9	C X 2

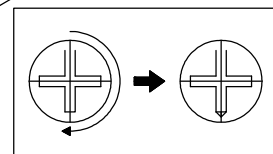

Lock Minifix cap clockwise

# ASSEMBLY INSTRUCTION

Item : N715P396292/N715P396293

---

## Step 8

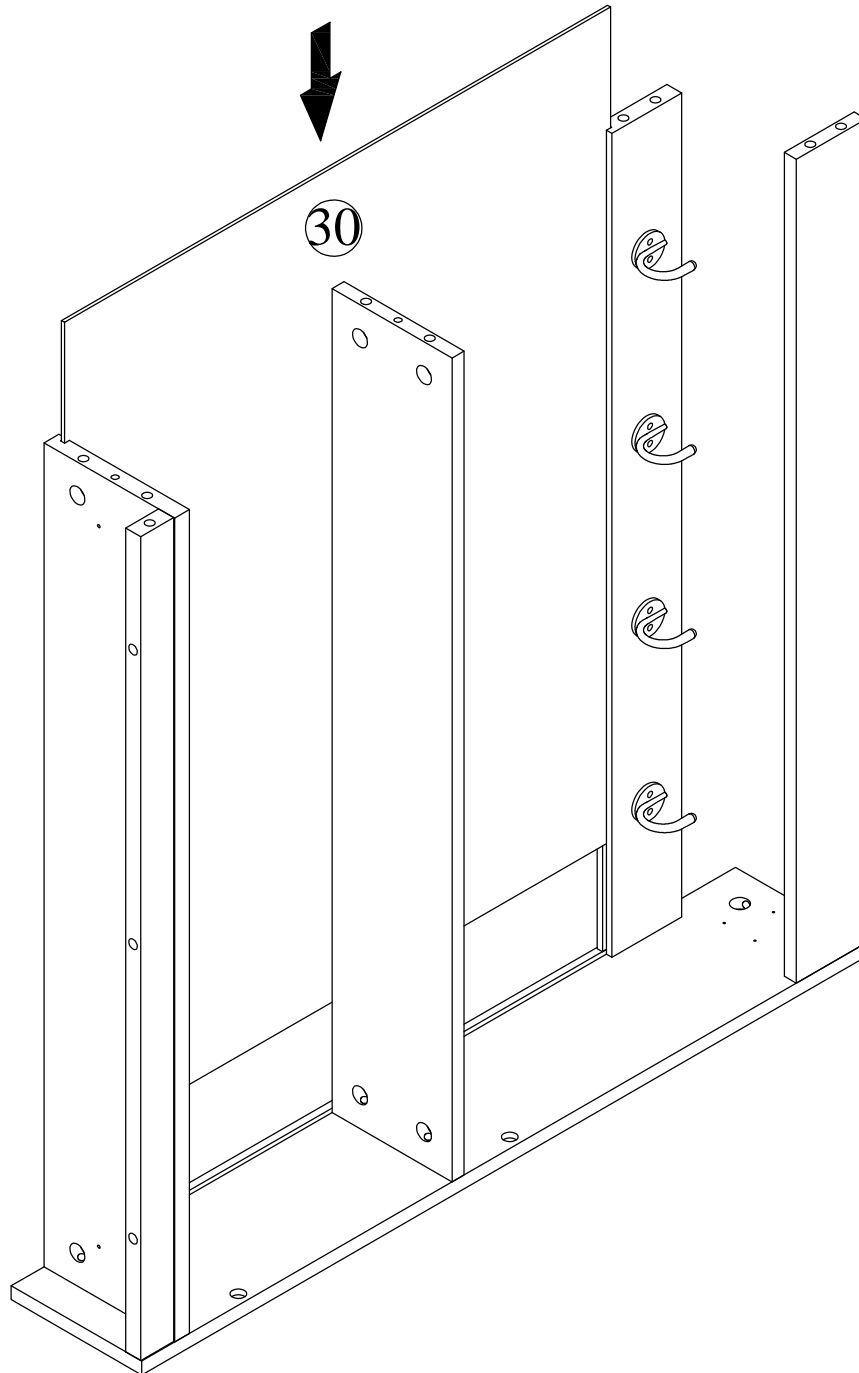



# ASSEMBLY INSTRUCTION

## Item : N715P396292/N715P396293

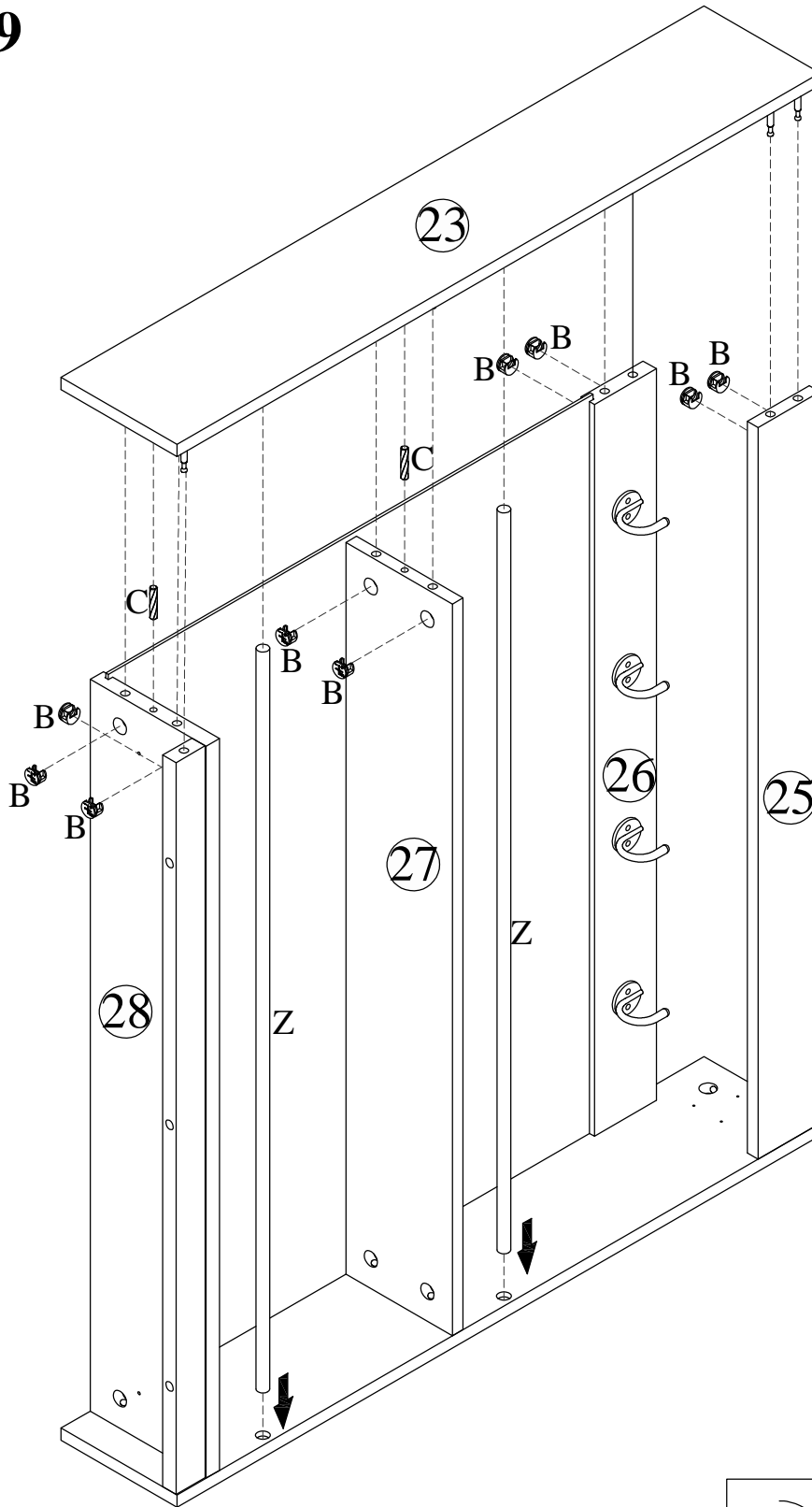
### Step 9

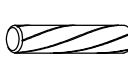

		
Ø15*9mm	Ø6*30mm	
B X 9	C X 2	Z X 2

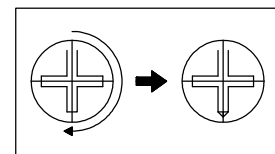



Lock Minifix cap clockwise

# ASSEMBLY INSTRUCTION

## Item : N715P396292/N715P396293

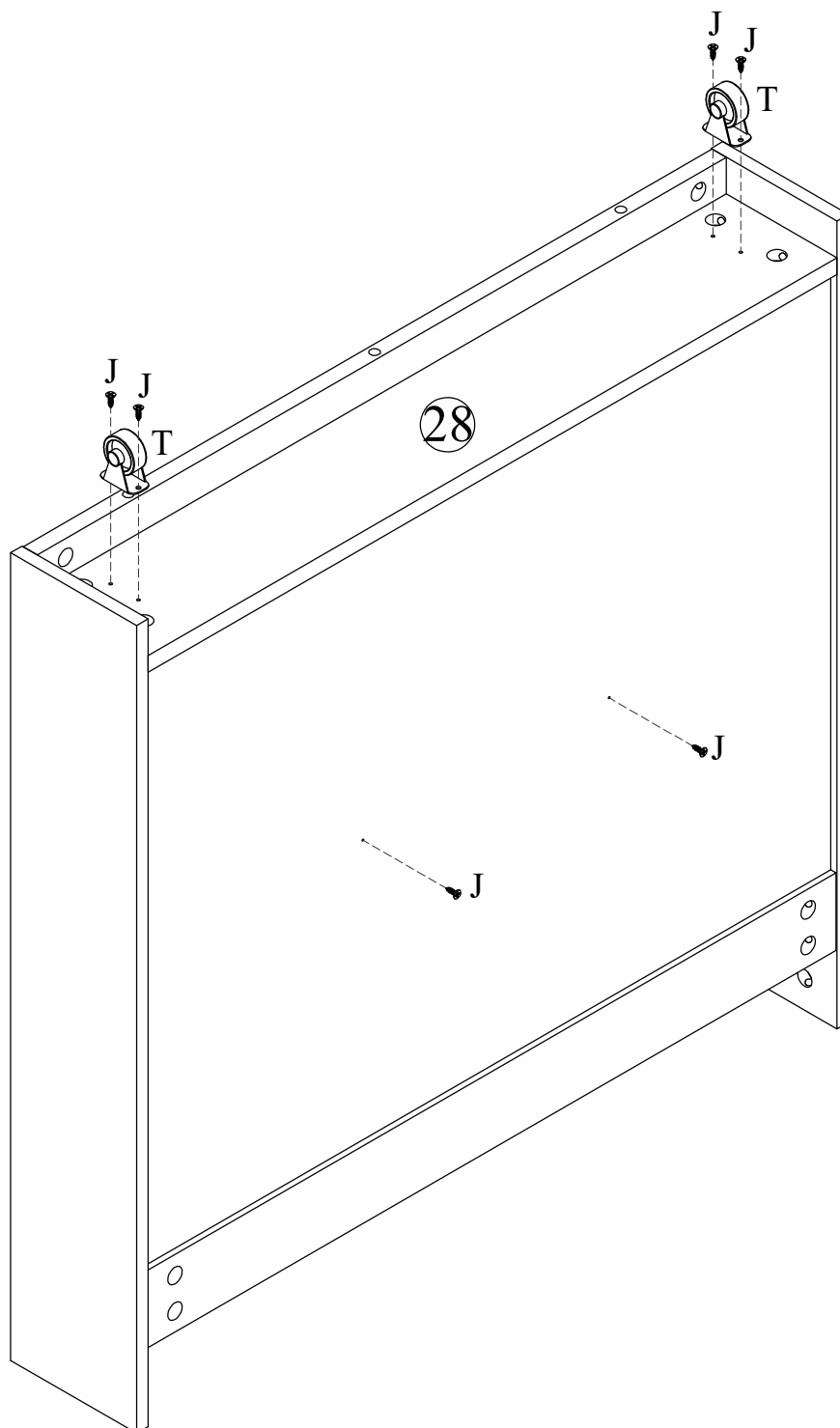
### Step 10



 3*12mm	
J X 6	T X 2

# ASSEMBLY INSTRUCTION

Item : N715P396292/N715P396293

## Step 11

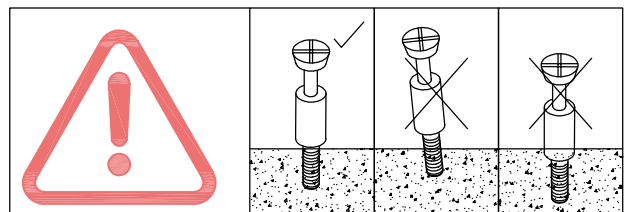
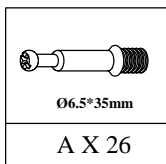
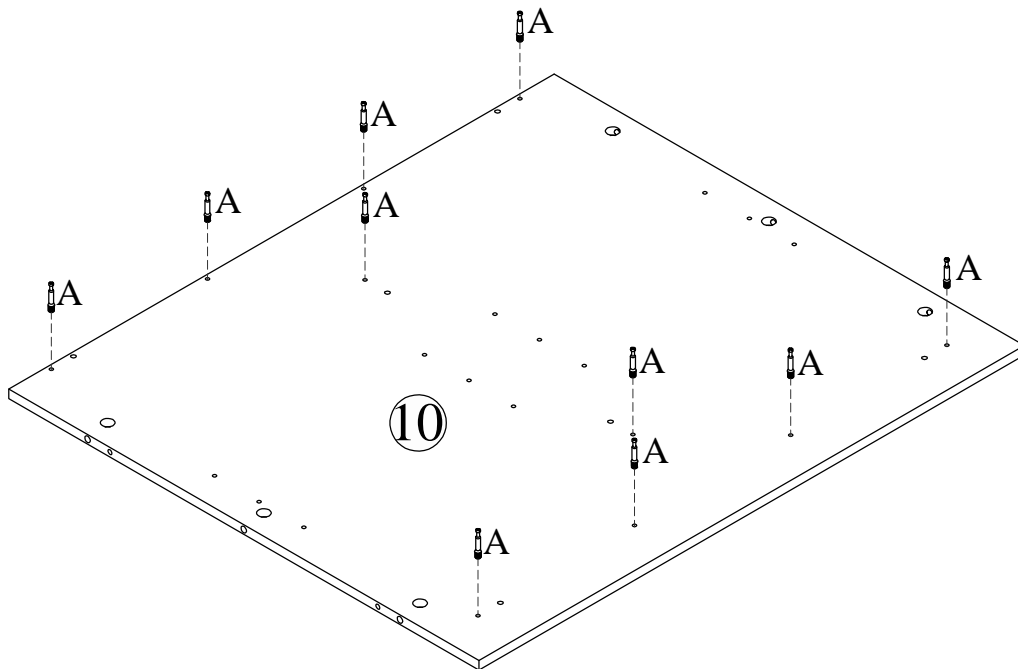
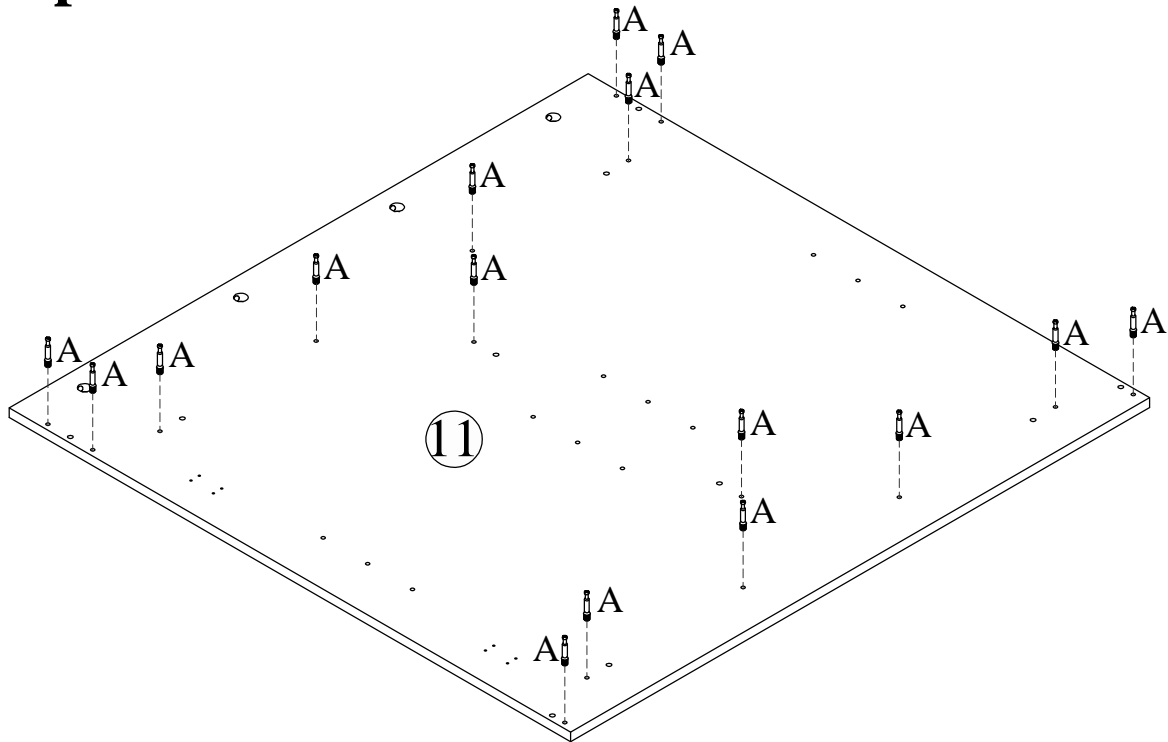



# ASSEMBLY INSTRUCTION

## Item : N715P396292/N715P396293

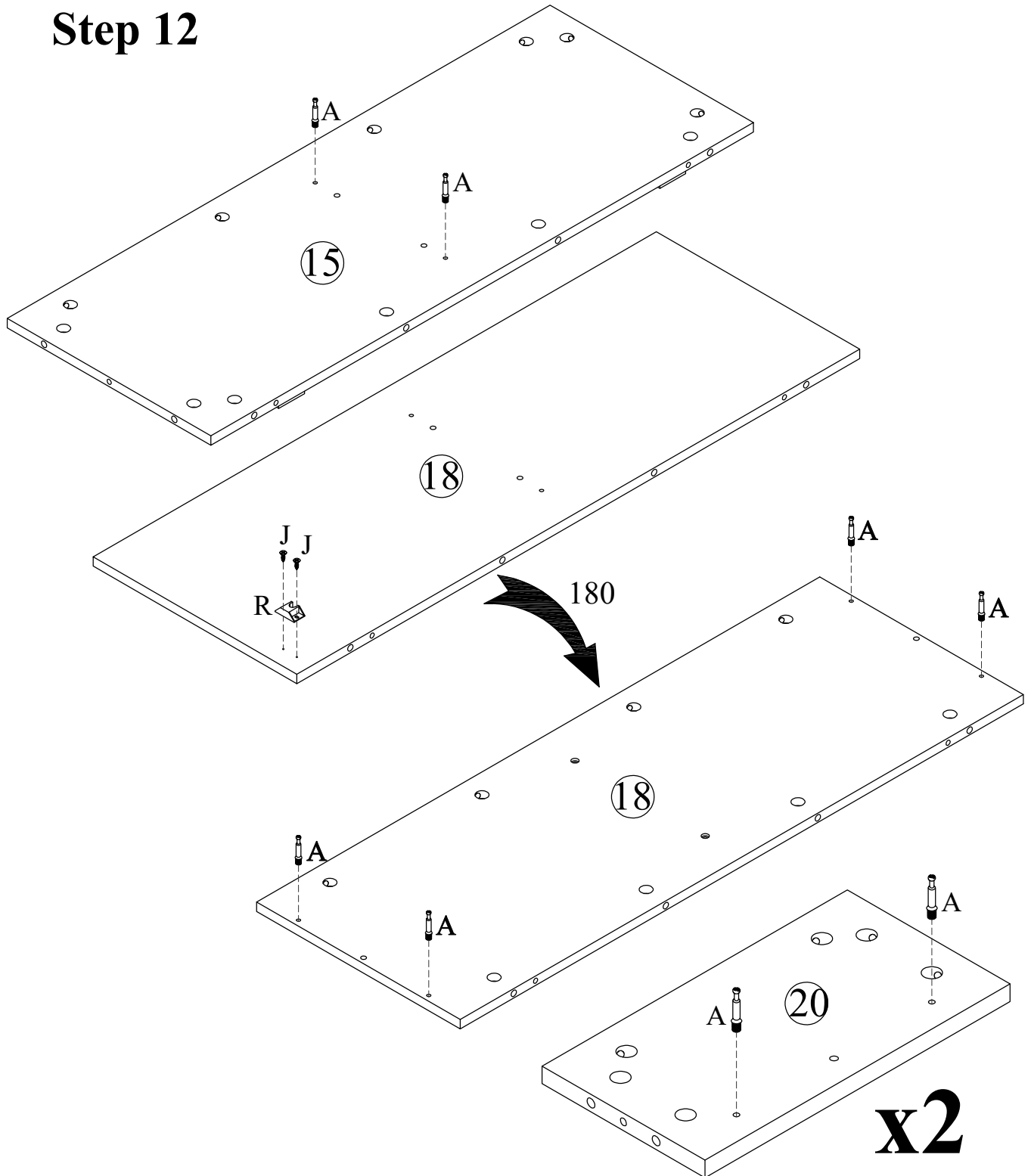
### Step 12

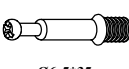

		
Ø6.5*35mm	Ø3*12mm	
A X 10	J X 2	R X 1

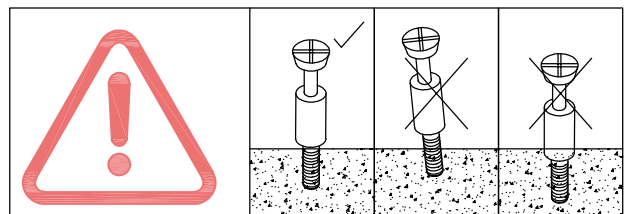



# ASSEMBLY INSTRUCTION

## Item : N715P396292/N715P396293

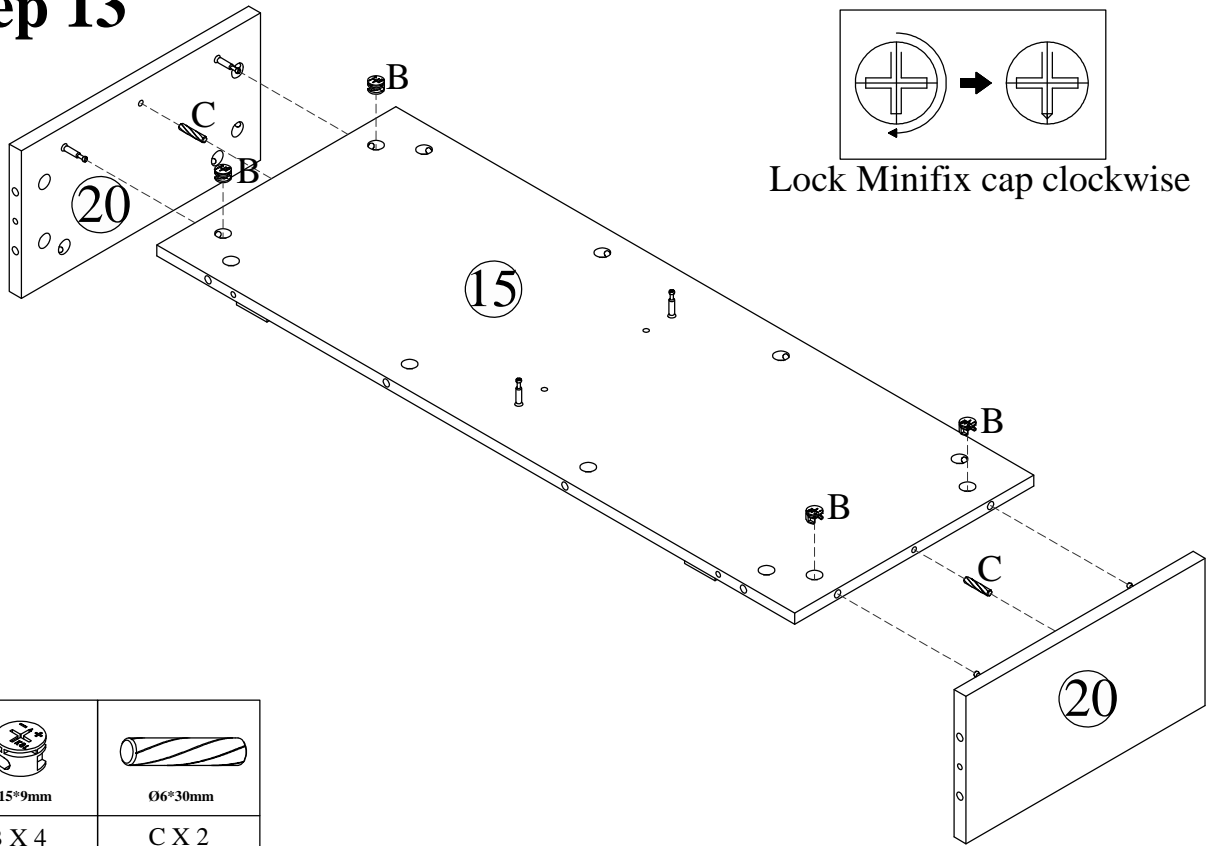

### Step 13

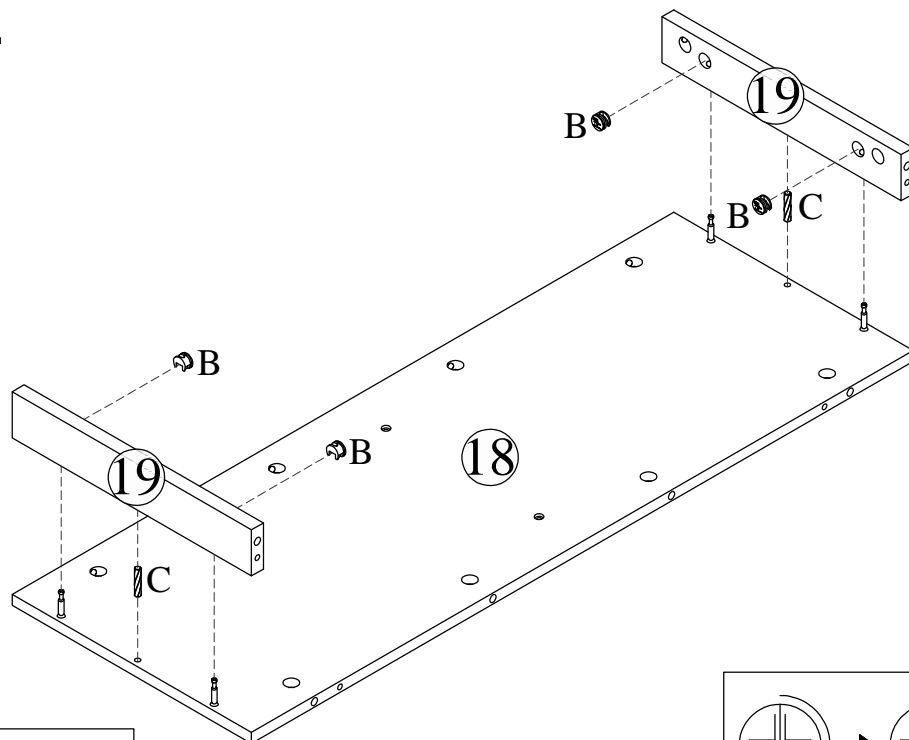

	
Ø15*9mm	Ø6*30mm
B X 4	C X 2

### Step 14



	
Ø15*9mm	Ø6*30mm
B X 4	C X 2

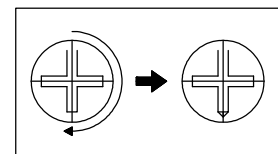



Lock Minifix cap clockwise

# ASSEMBLY INSTRUCTION

## Item : N715P396292/N715P396293

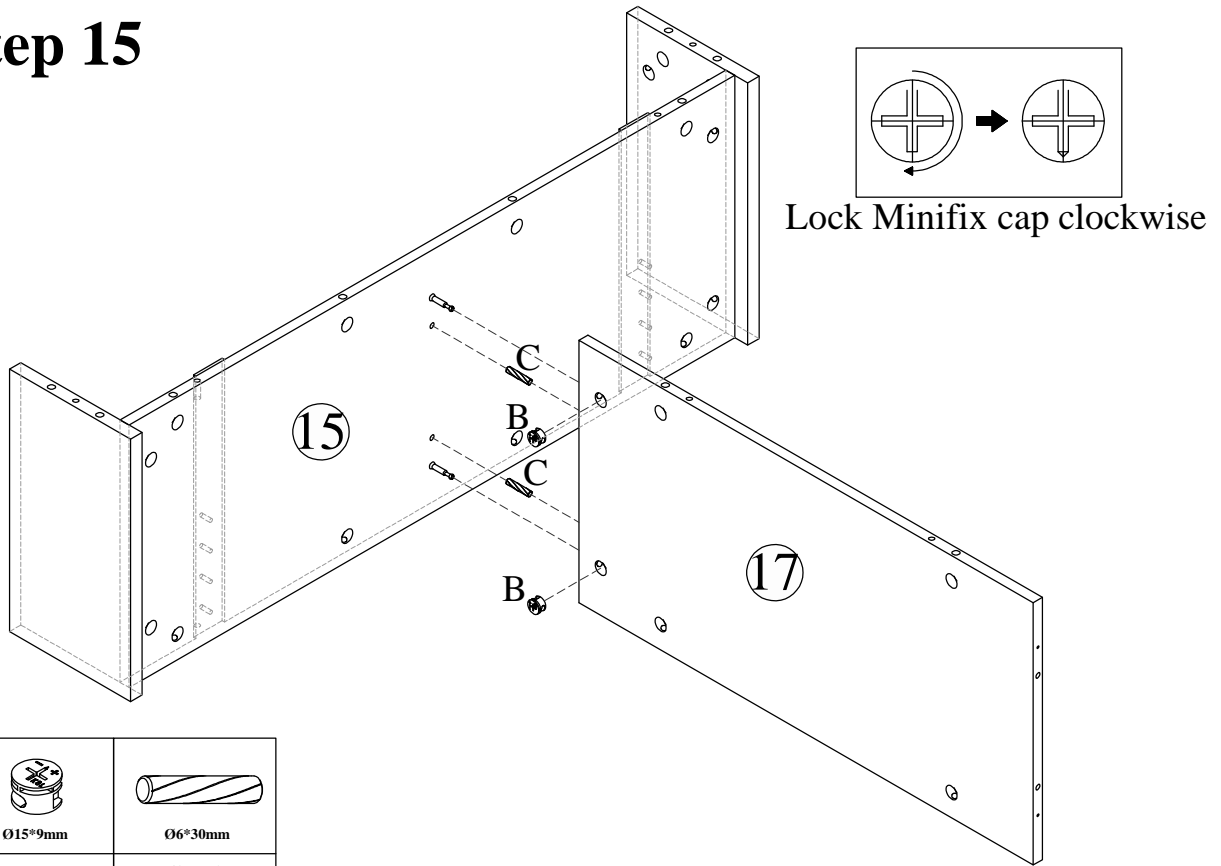

### Step 15

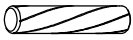

	
Ø15*9mm	Ø6*30mm
B X 2	C X 2

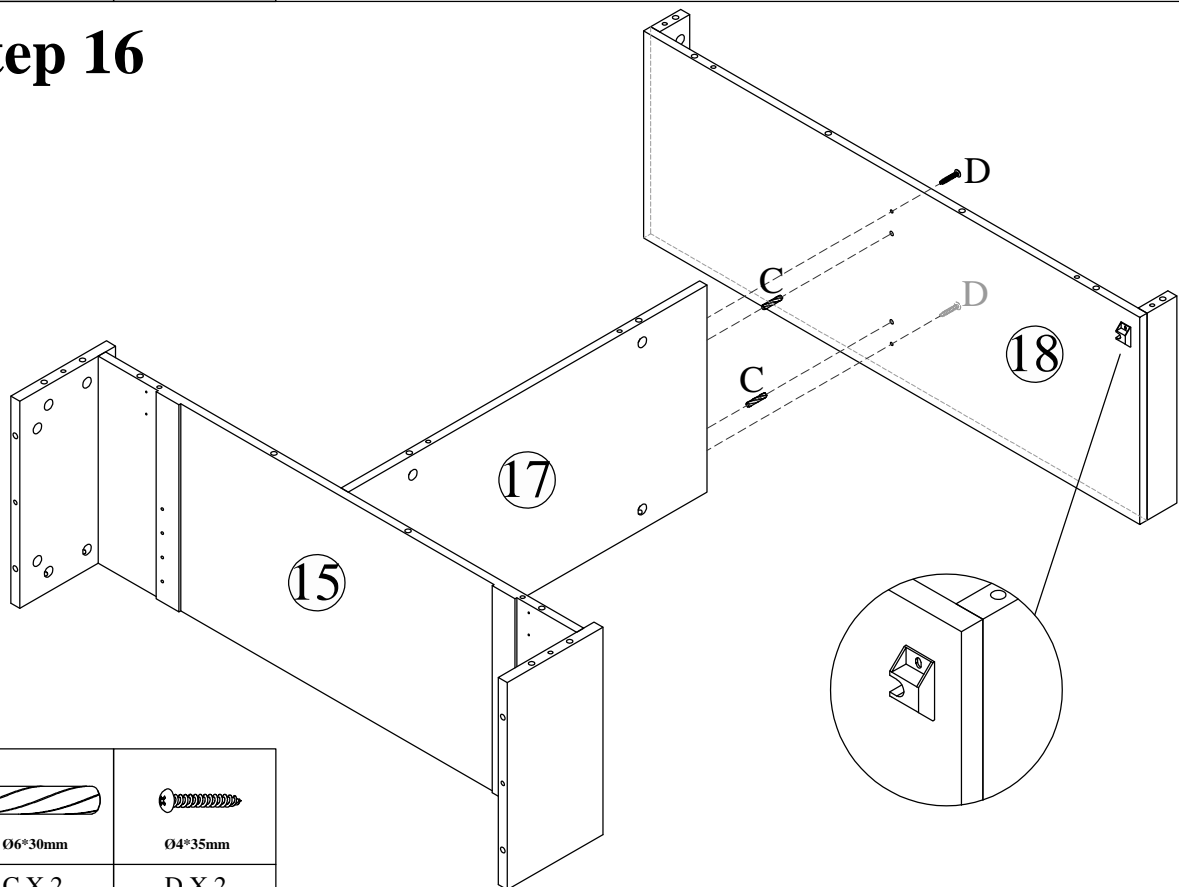
### Step 16

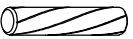



	
Ø6*30mm	Ø4*35mm
C X 2	D X 2

# ASSEMBLY INSTRUCTION

## Item : N715P396292/N715P396293

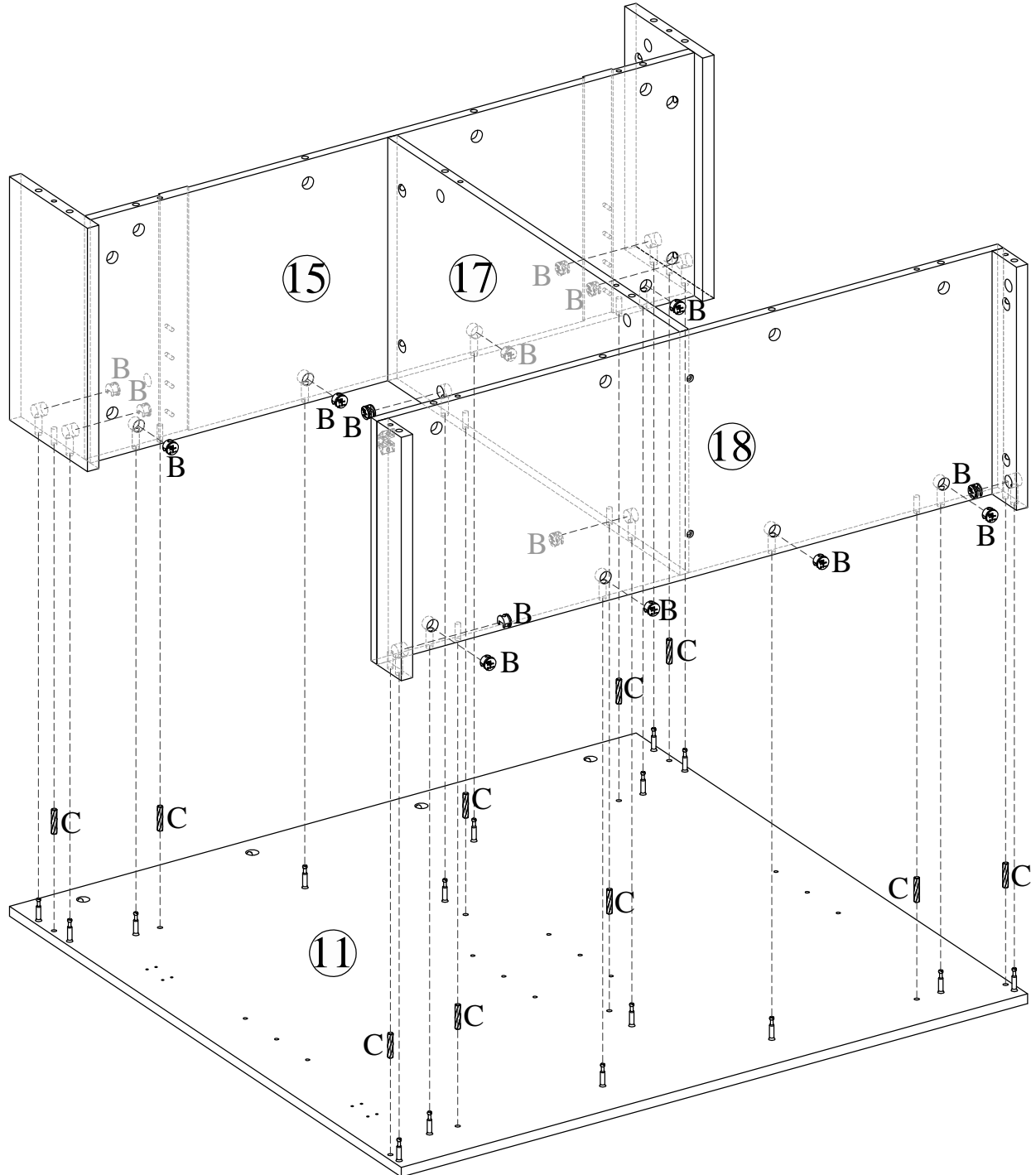
### Step 17

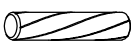

 Ø15*9mm	 Ø6*30mm
B X 16	C X 10

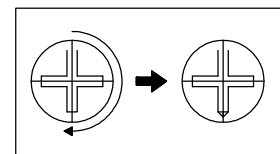

Lock Minifix cap clockwise

# ASSEMBLY INSTRUCTION

Item : N715P396292/N715P396293

## Step 18

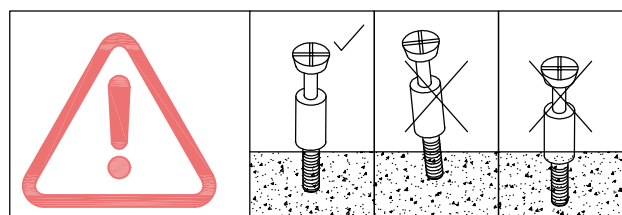
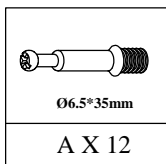
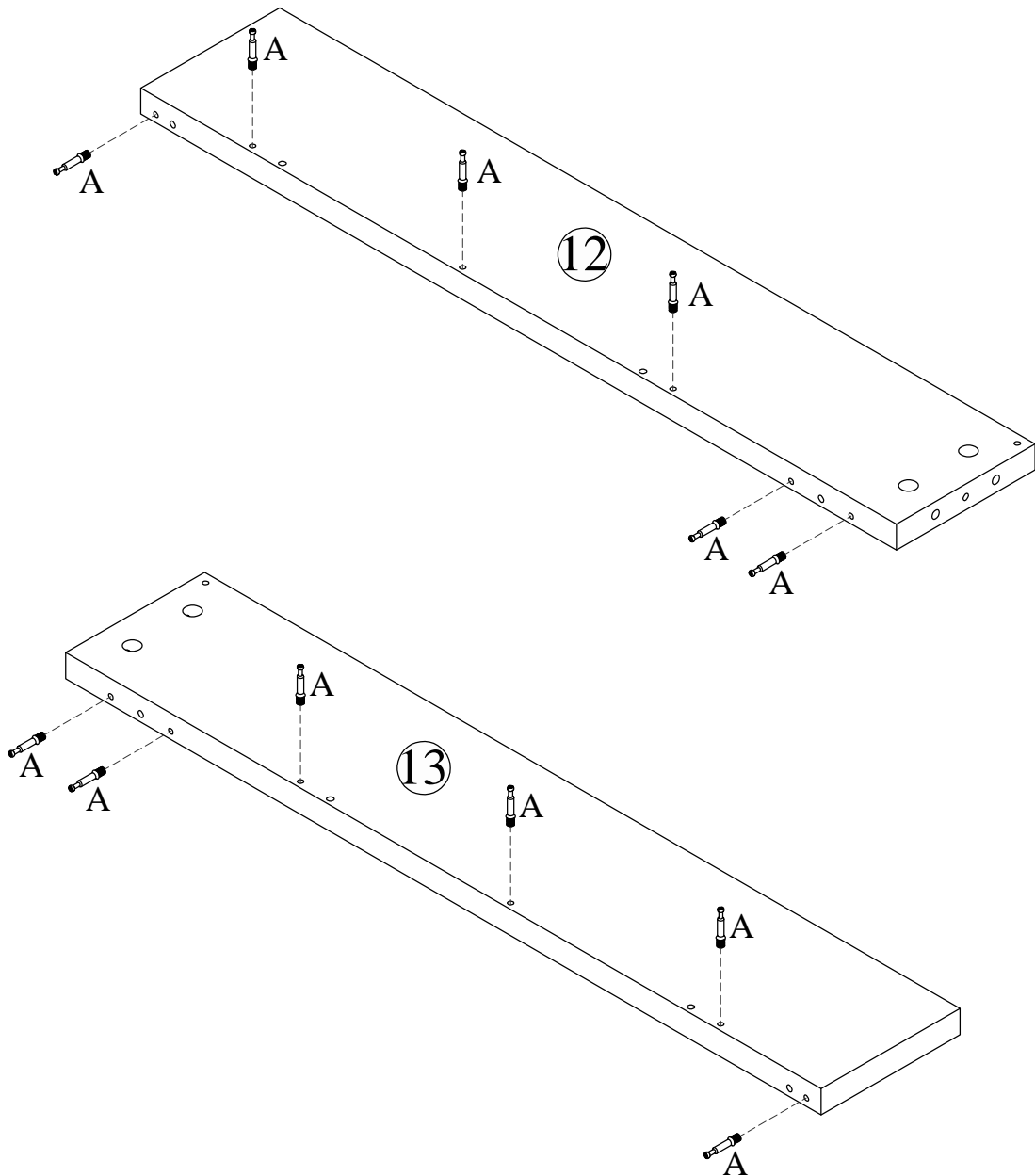

# ASSEMBLY INSTRUCTION

## Item : N715P396292/N715P396293

### Step 19

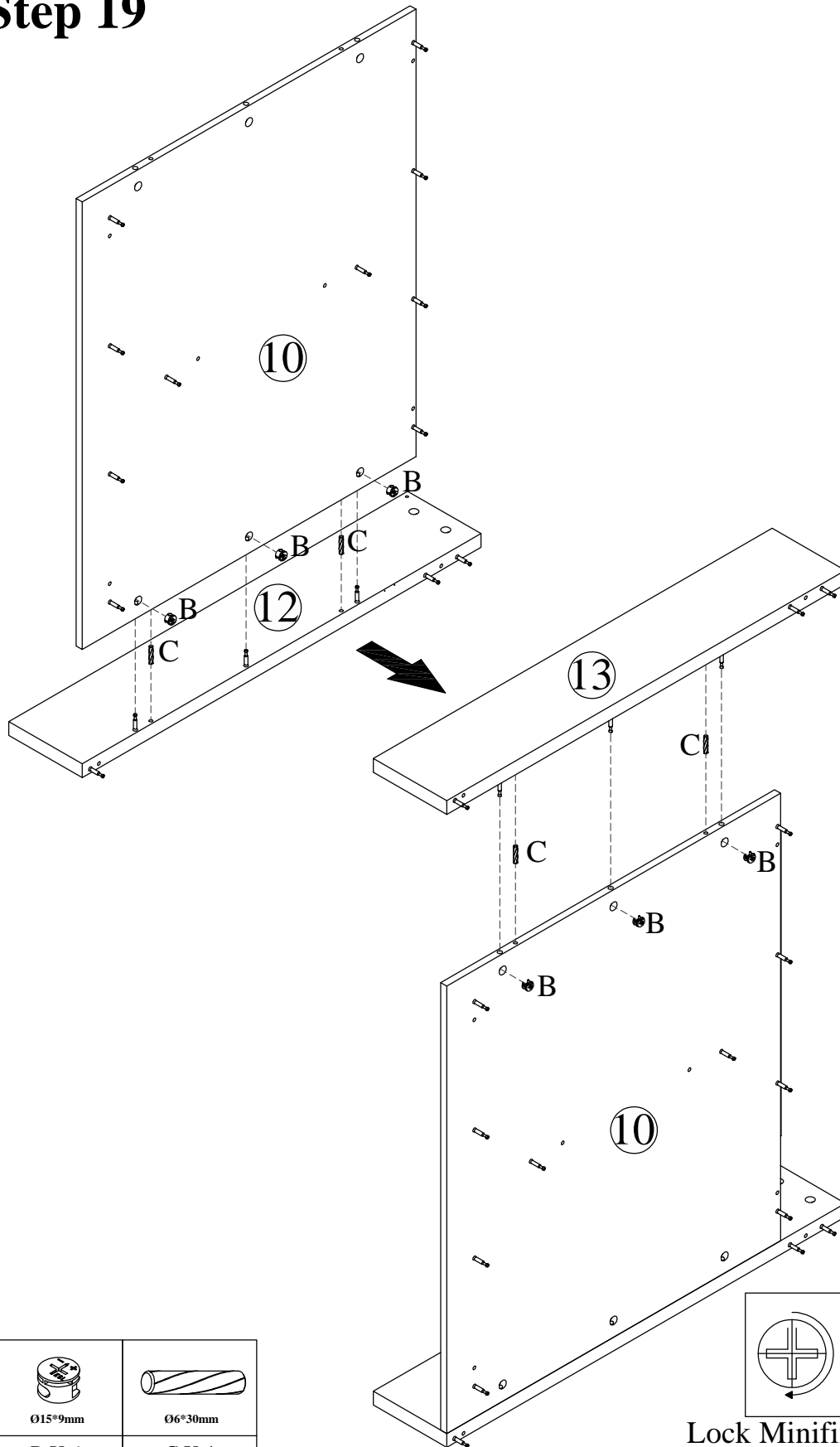

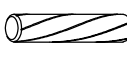
	
Ø15*9mm	Ø6*30mm
B X 6	C X 4

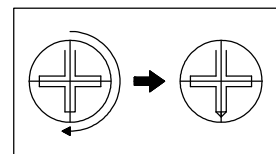



Lock Minifix cap clockwise

# ASSEMBLY INSTRUCTION

## Item : N715P396292/N715P396293

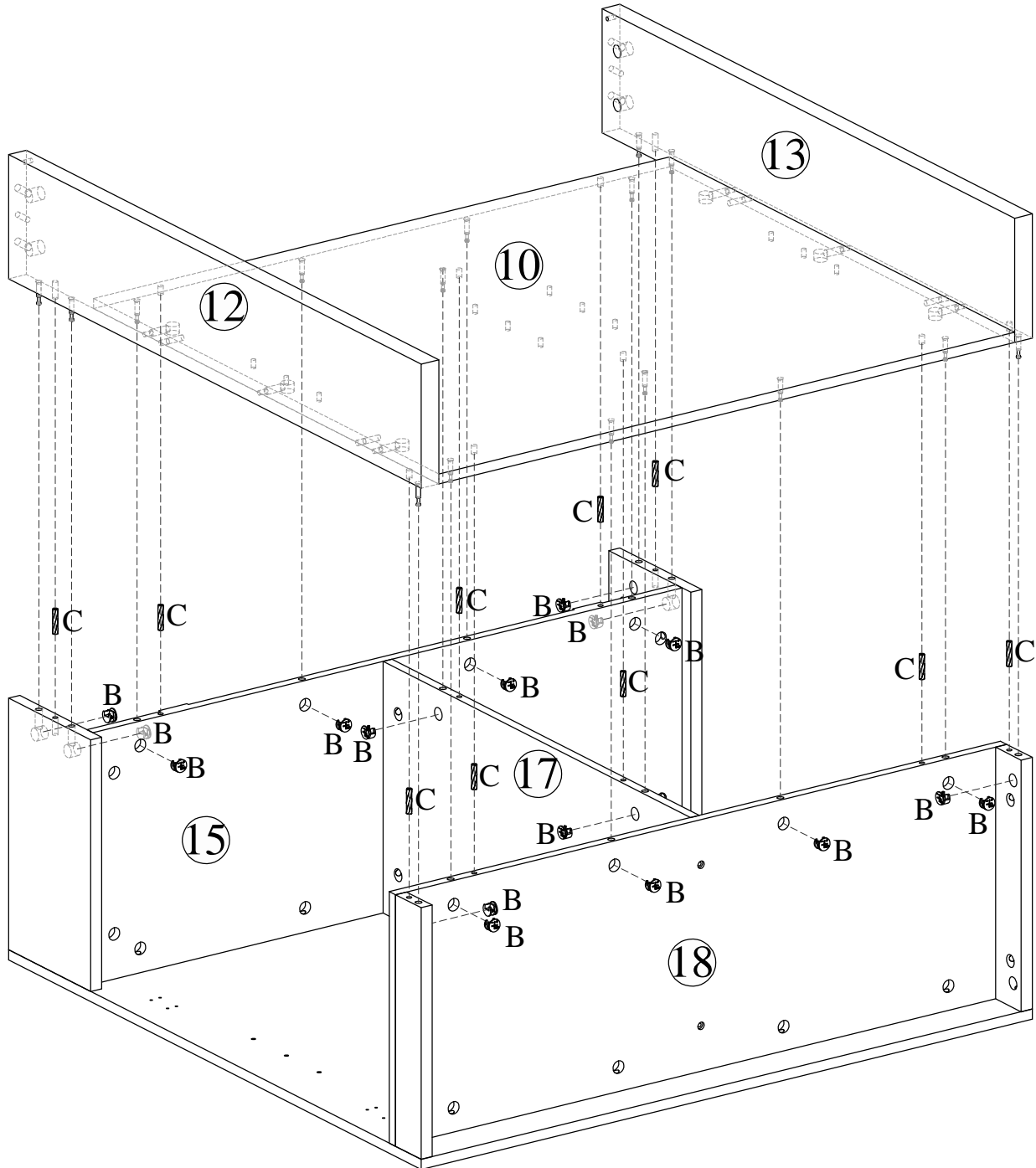
### Step 20

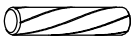

	
Ø15*9mm	Ø6*30mm
B X 16	C X 10

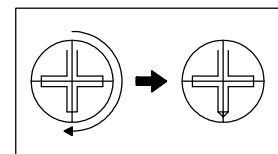

Lock Minifix cap clockwise

# ASSEMBLY INSTRUCTION

Item : N715P396292/N715P396293

## Step 21

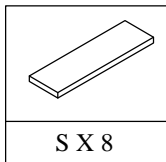
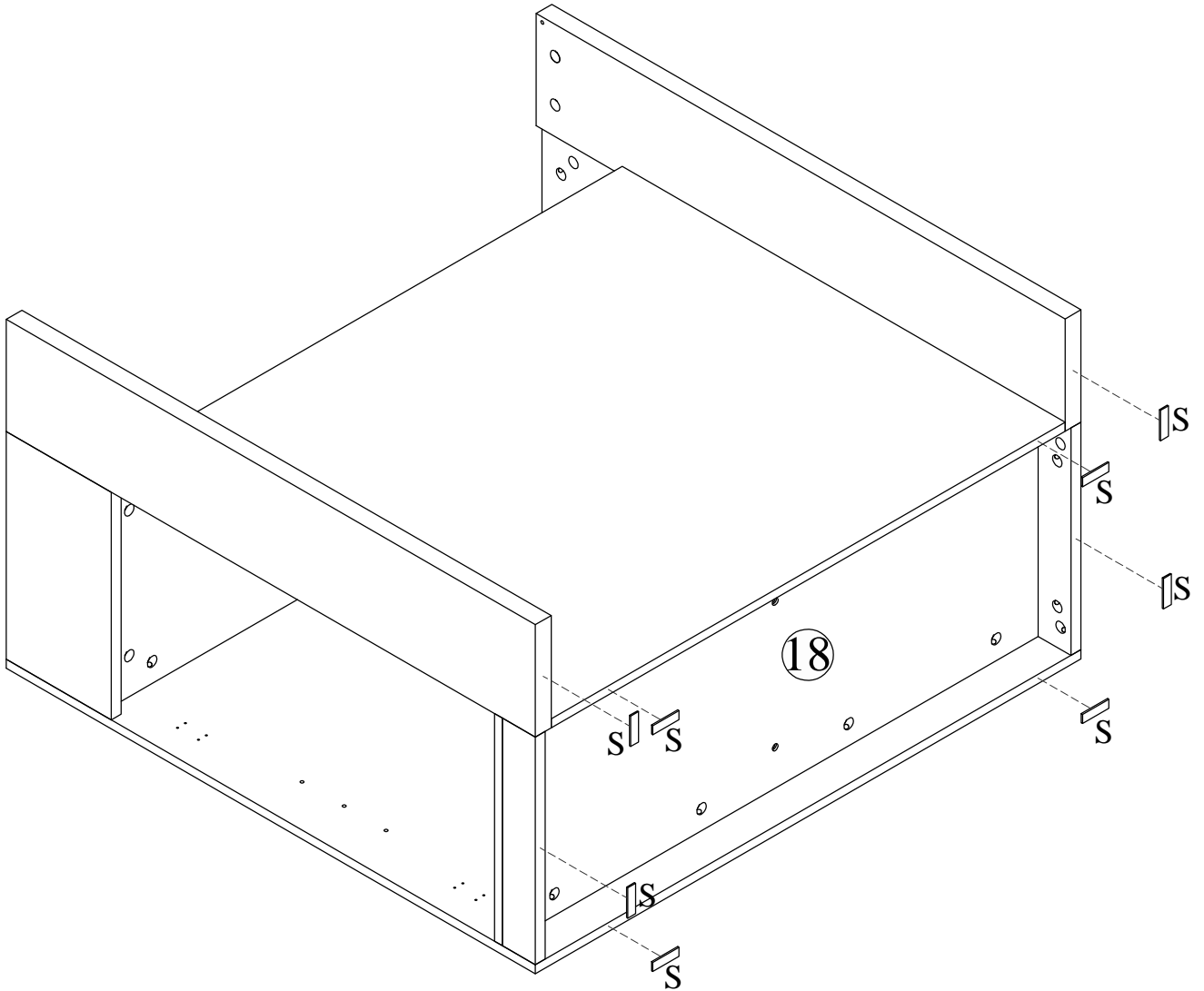

# ASSEMBLY INSTRUCTION

Item : N715P396292/N715P396293

## Step 22

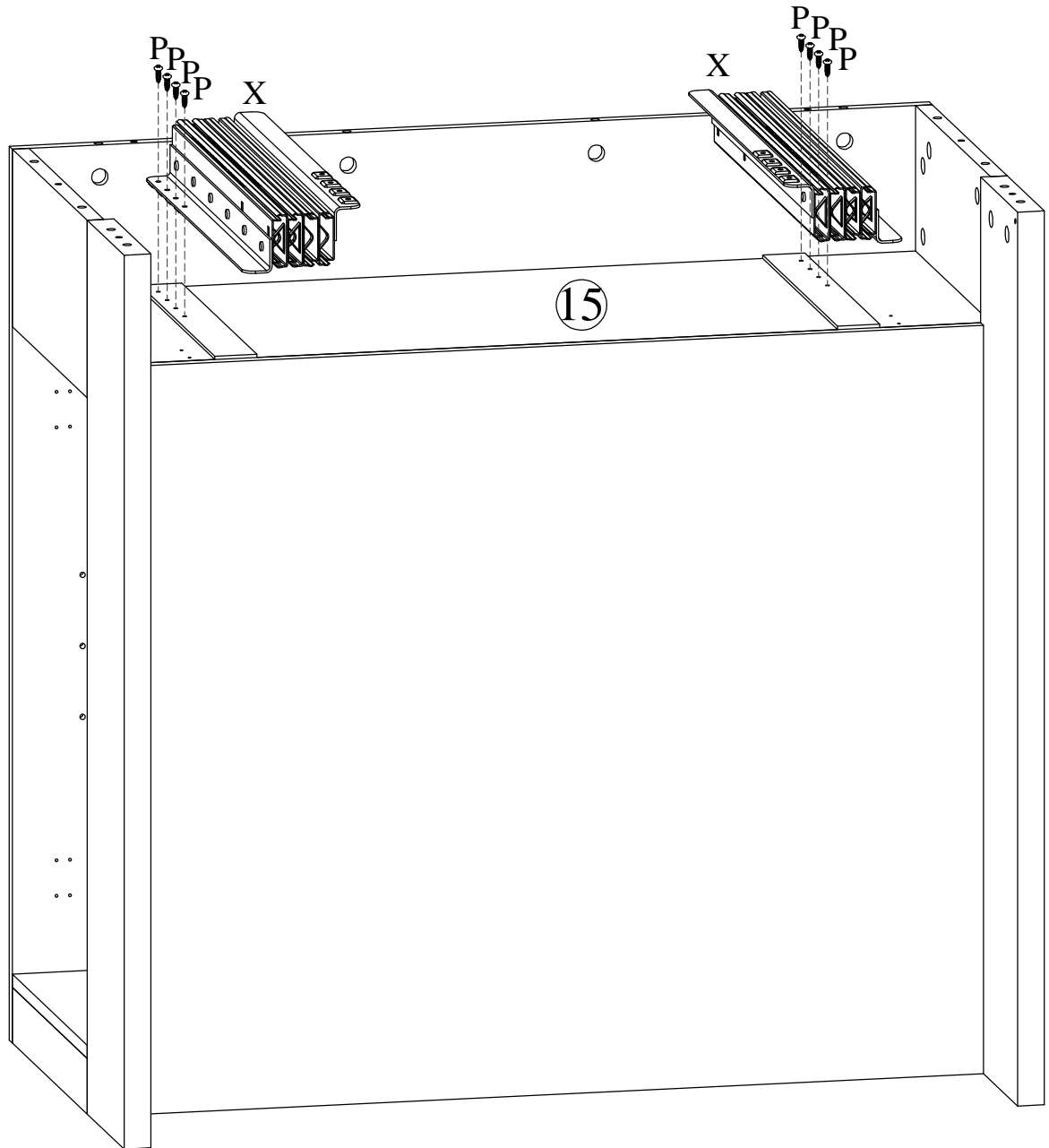

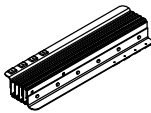



 Ø5*16mm	
P X 8	X X 2

# ASSEMBLY INSTRUCTION

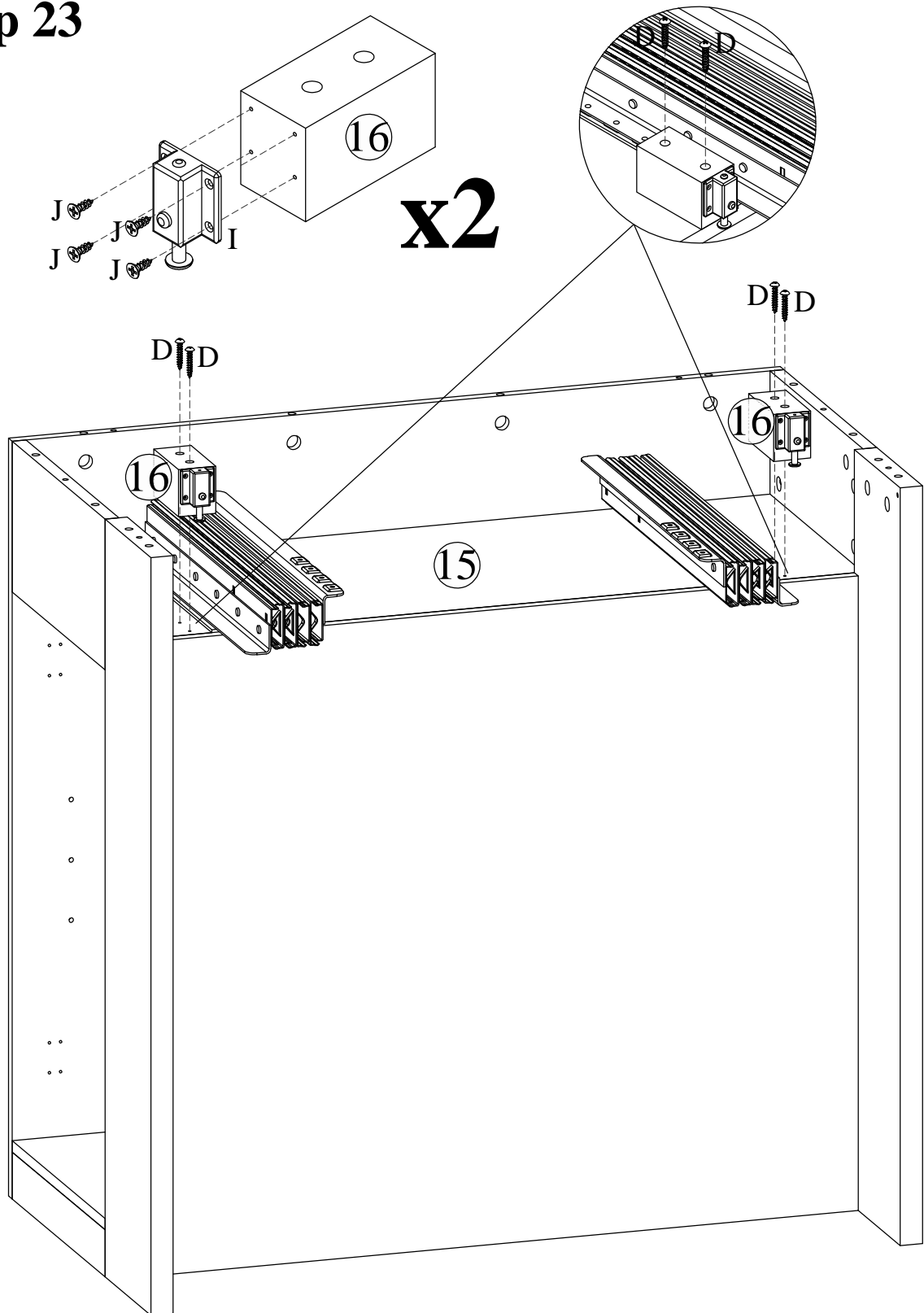
## Item : N715P396292/N715P396293

### Step 23



		
Ø4*35mm		Ø3*12mm
D X 4	I X 2	J X 8

# ASSEMBLY INSTRUCTION

Item : N715P396292/N715P396293

## Step 24

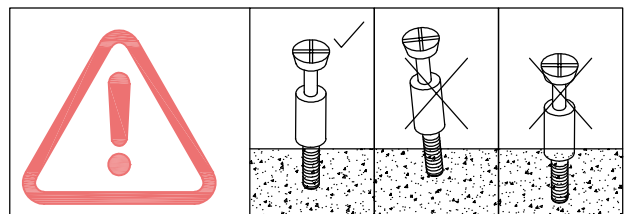
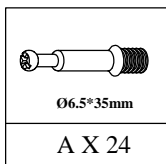
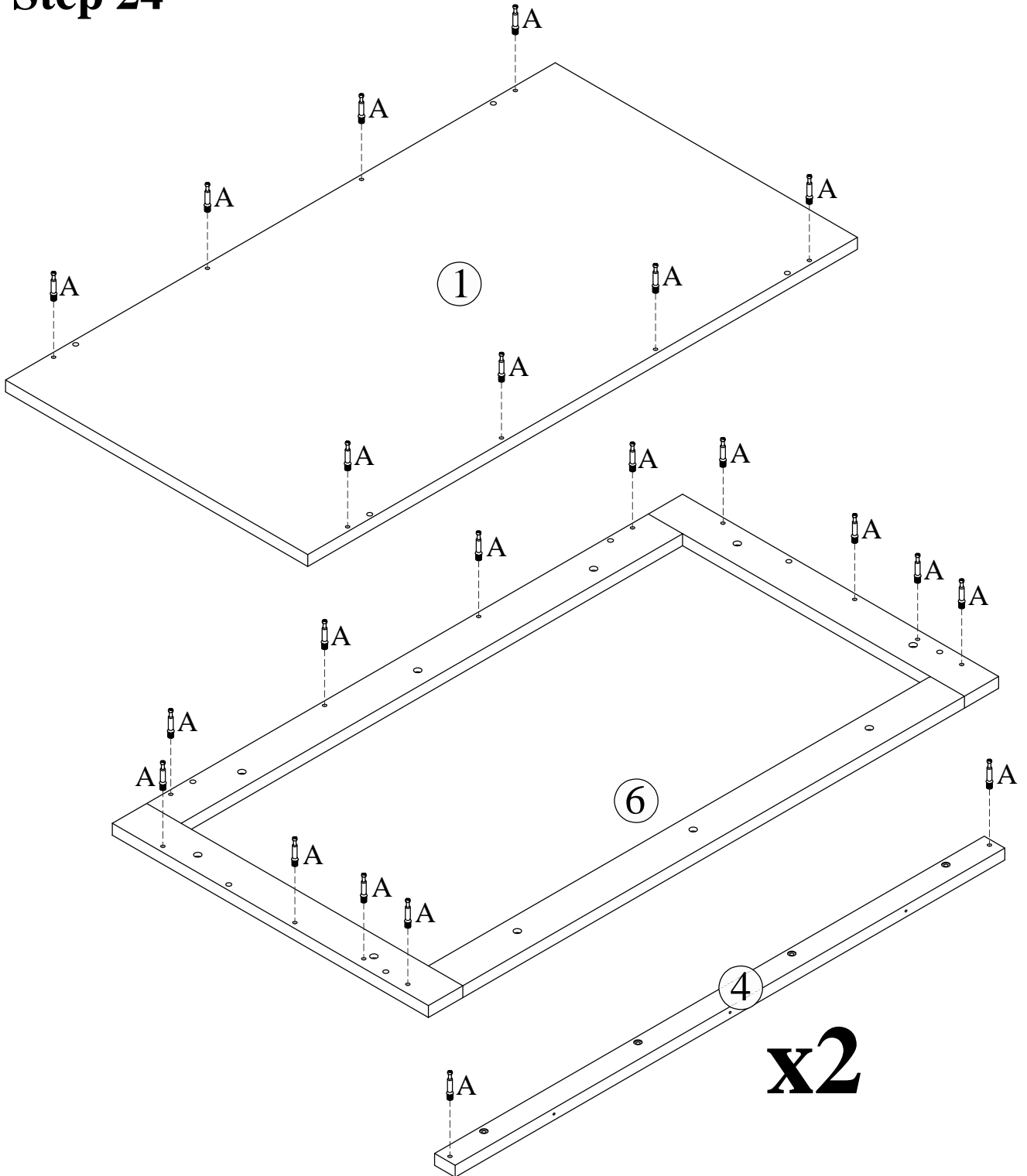



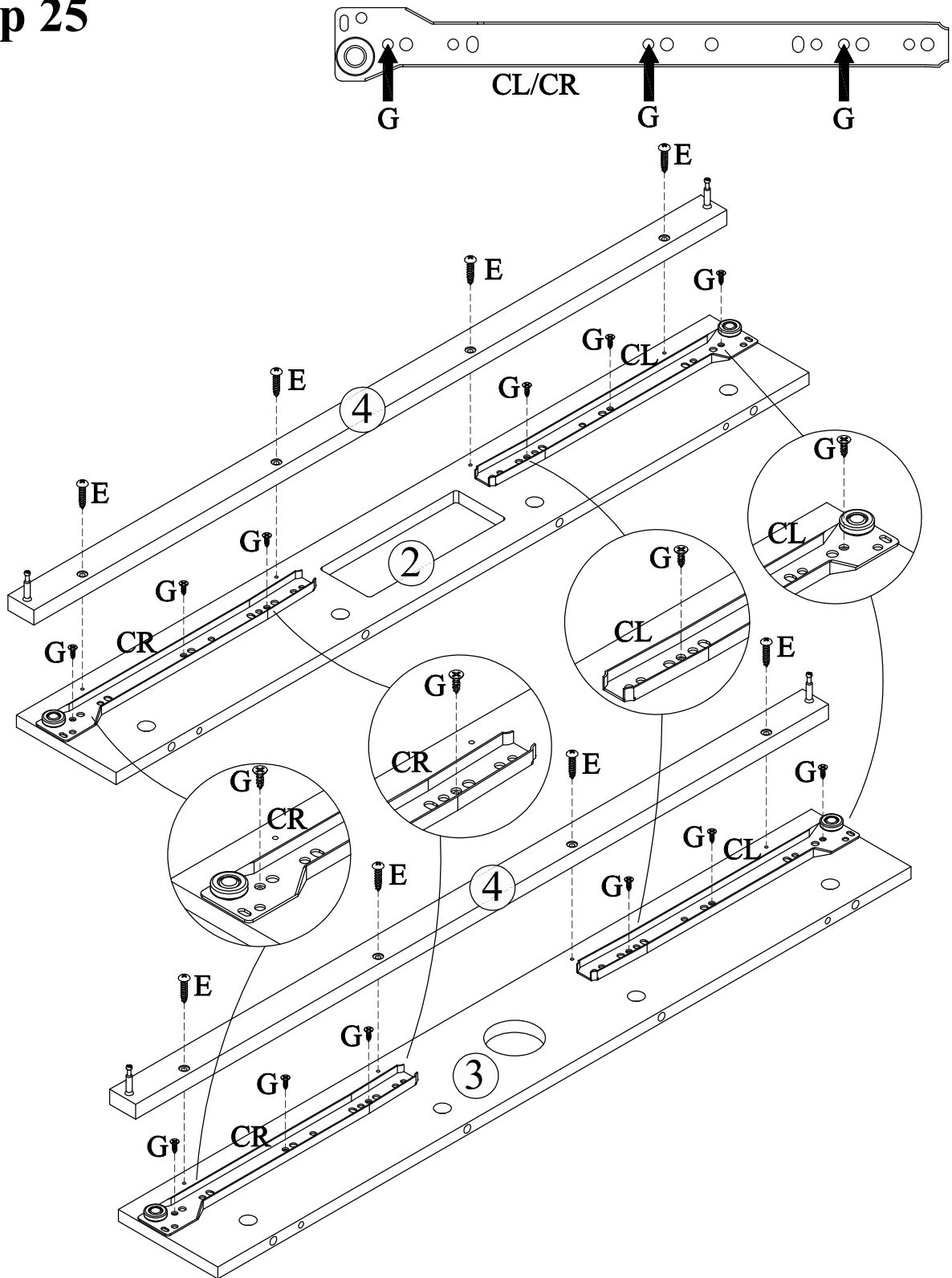

# ASSEMBLY INSTRUCTION

## Item : N715P396292/N715P396293

### Step 25





			
Ø4*25mm	Ø4*12mm	300mm	300mm
E X 8	G X 12	CL X 2	CR X 2

# ASSEMBLY INSTRUCTION

## Item : N715P396292/N715P396293

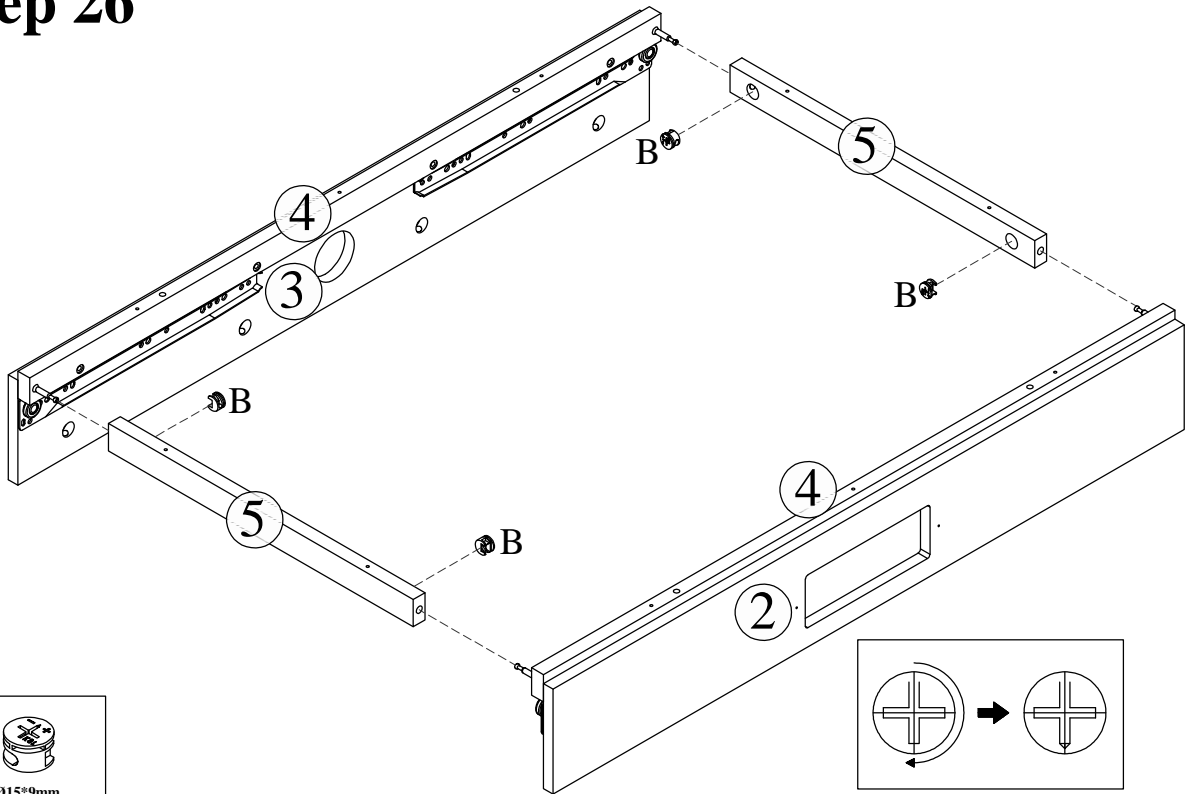
### Step 26



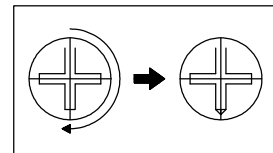

 015*9mm
B X 4

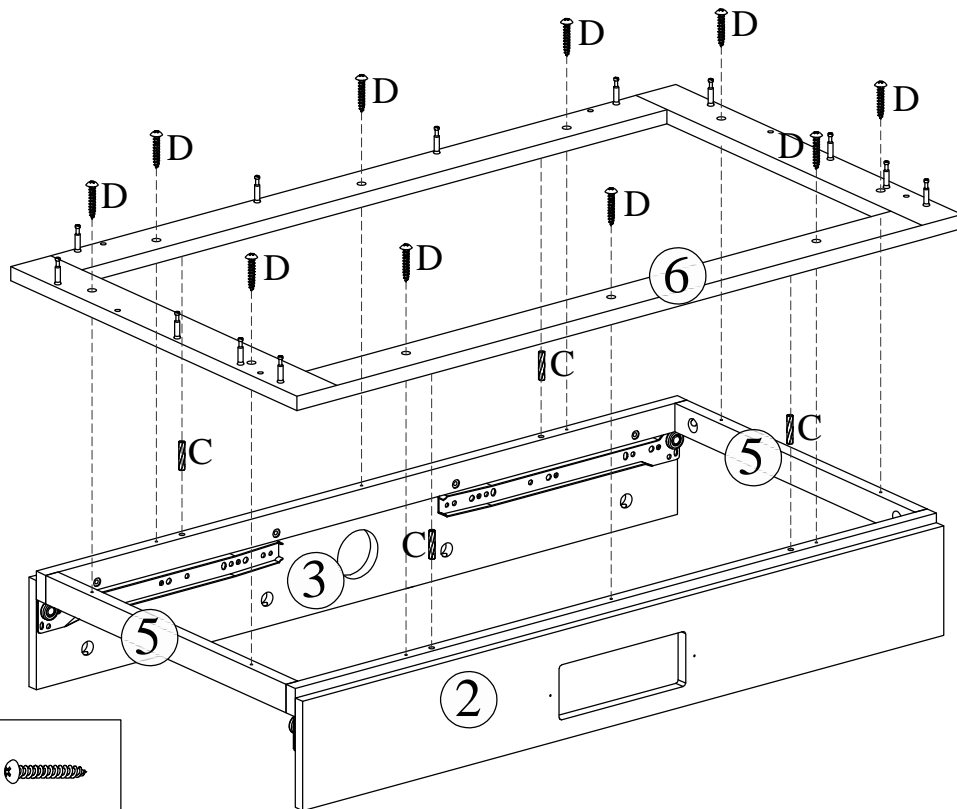

Lock Minifix cap clockwise

### Step 27

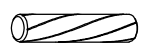



 06*30mm	 04*35mm
C X 4	D X 10

# ASSEMBLY INSTRUCTION

## Item : N715P396292/N715P396293

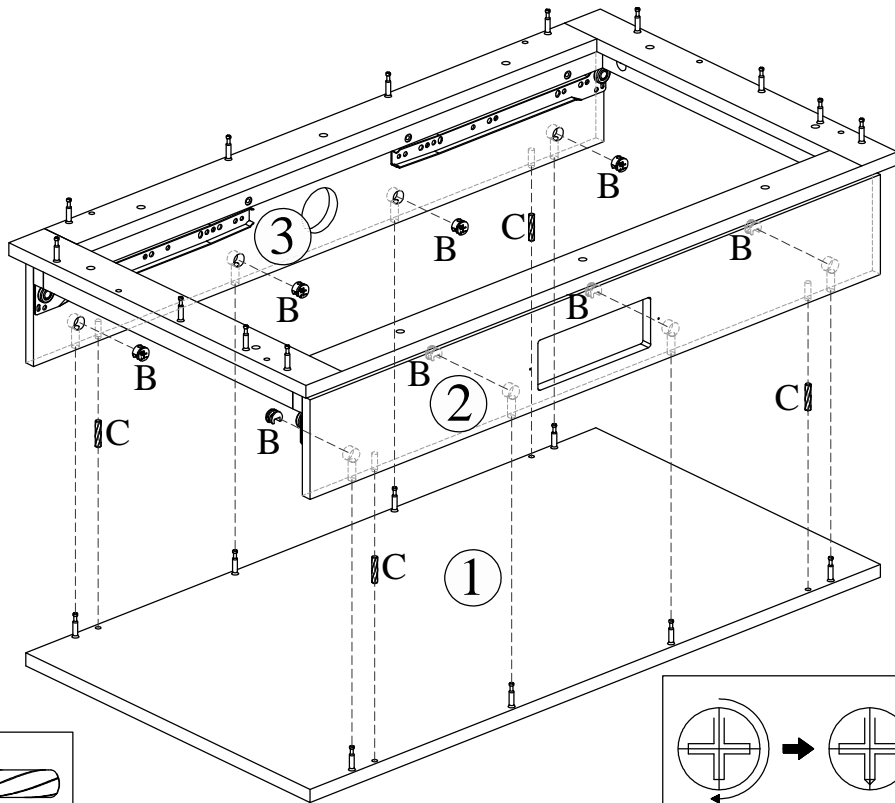
### Step 28



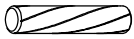

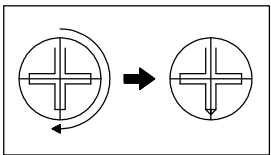
	
Ø15*9mm	Ø6*30mm
B X 8	C X 4

  
 Lock Minifix cap clockwise

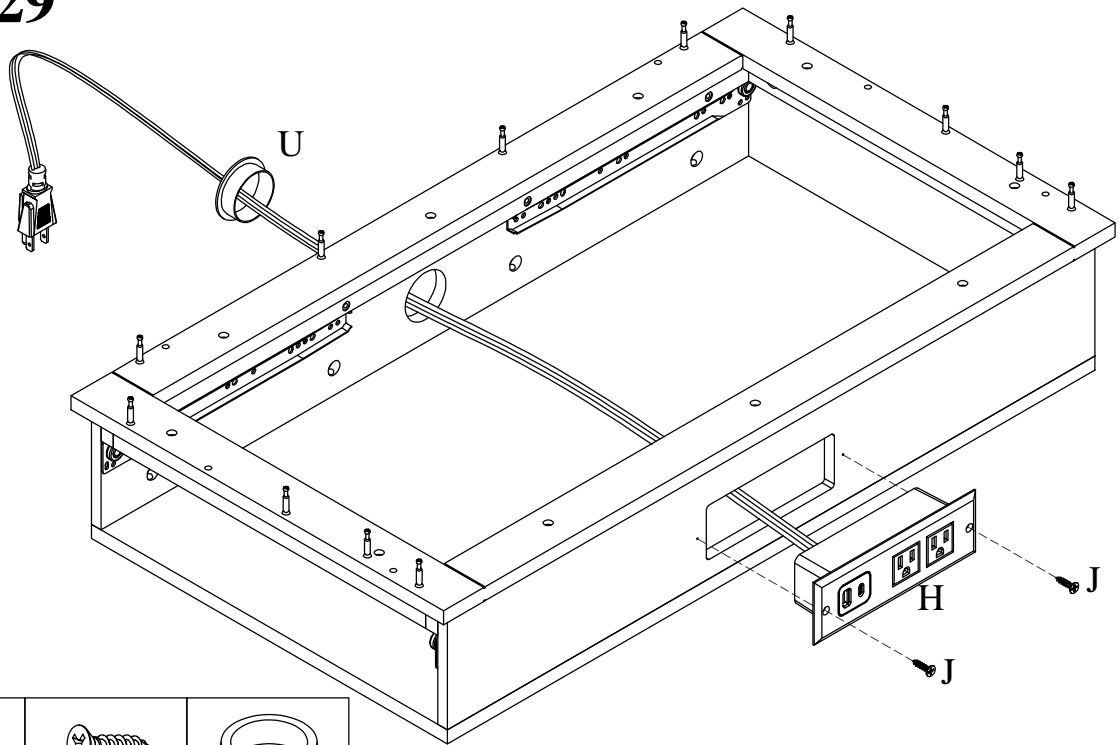
### Step 29





		
H X 1	J X 2	U X 1

# ASSEMBLY INSTRUCTION

## Item : N715P396292/N715P396293

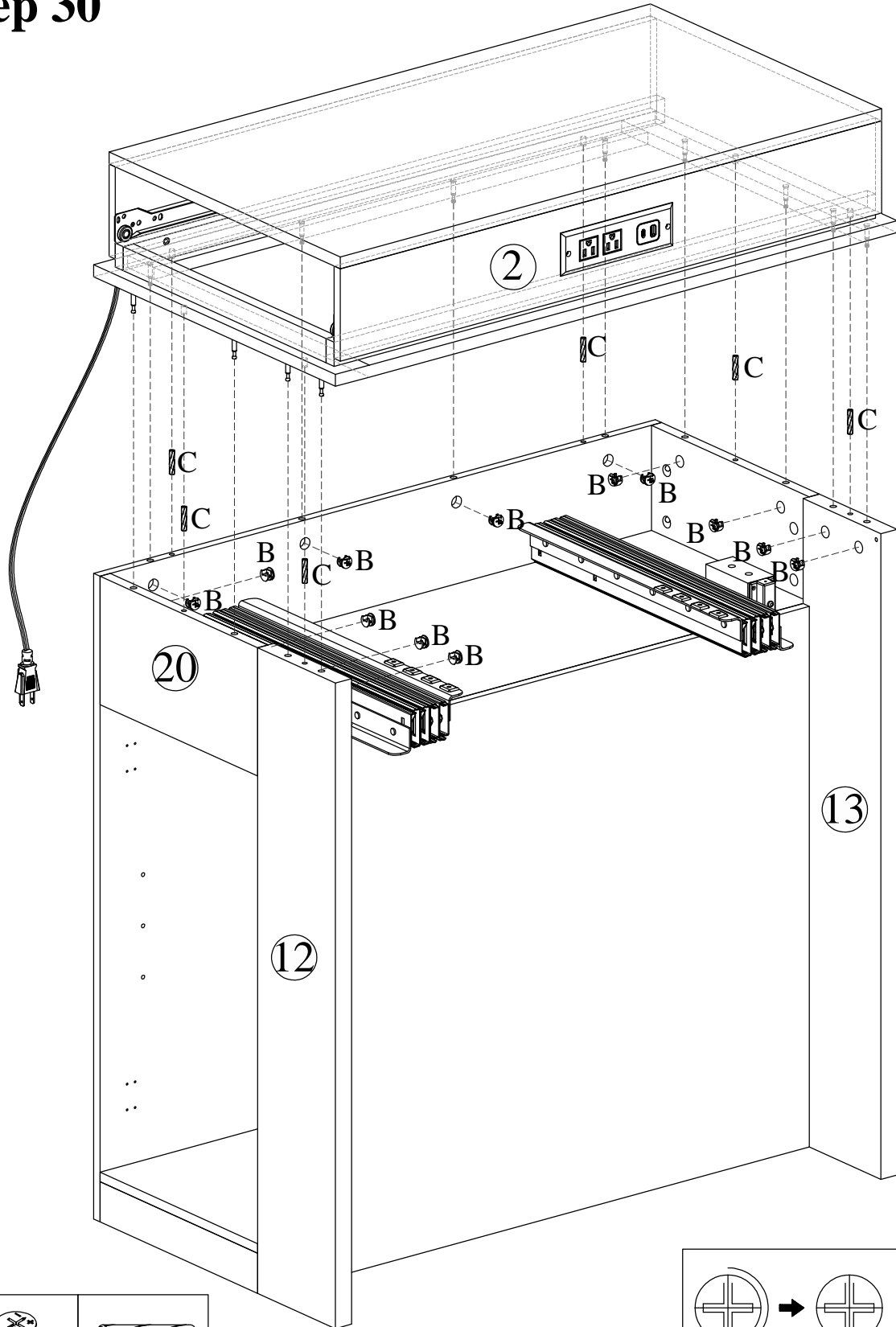
### Step 30

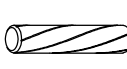

	
Ø15*9mm	Ø6*30mm
B X 12	C X 6

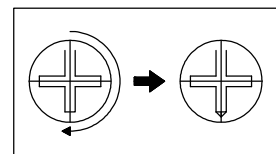

Lock Minifix cap clockwise

# ASSEMBLY INSTRUCTION

Item : N715P396292/N715P396293

## Step 31

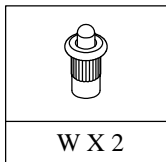
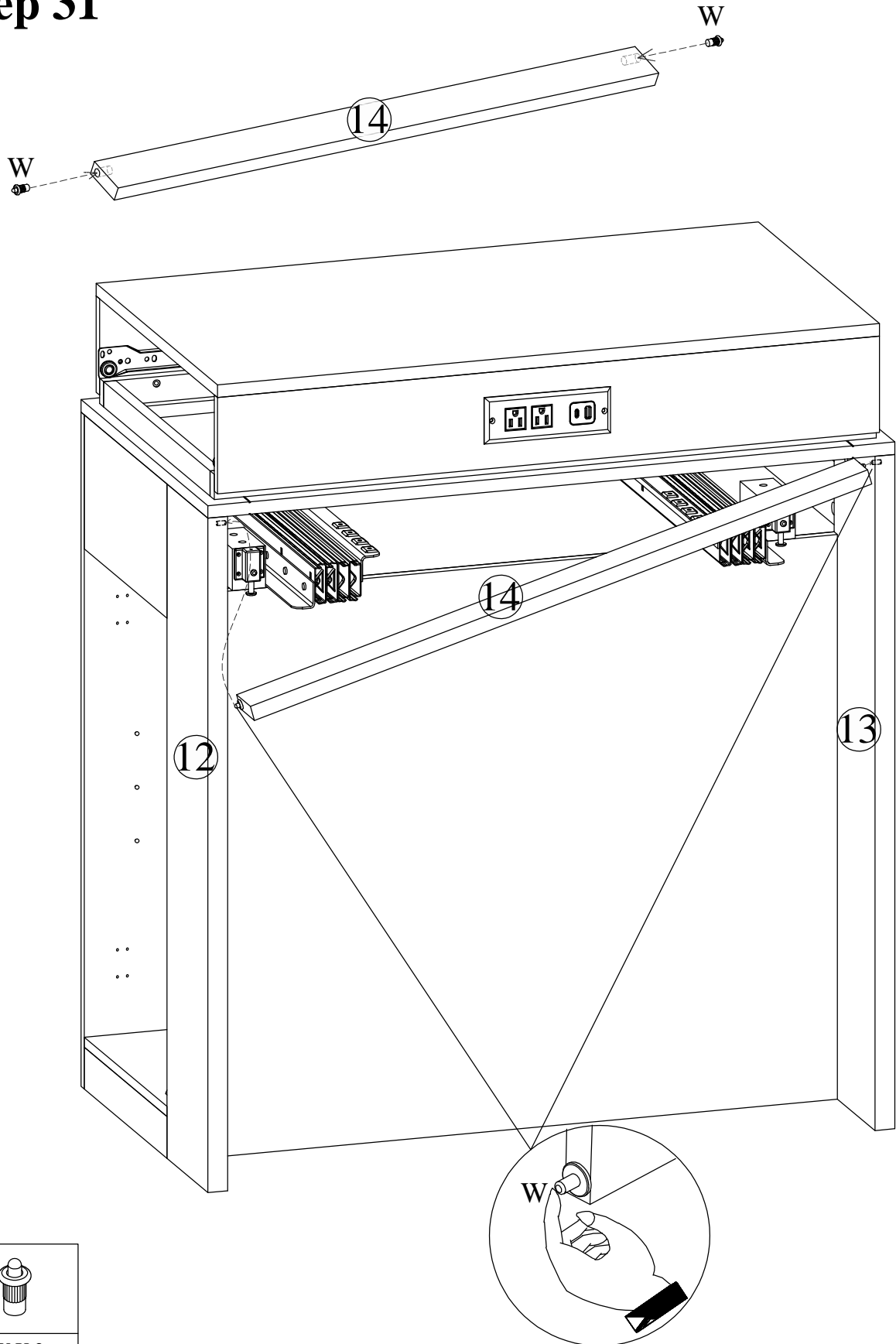



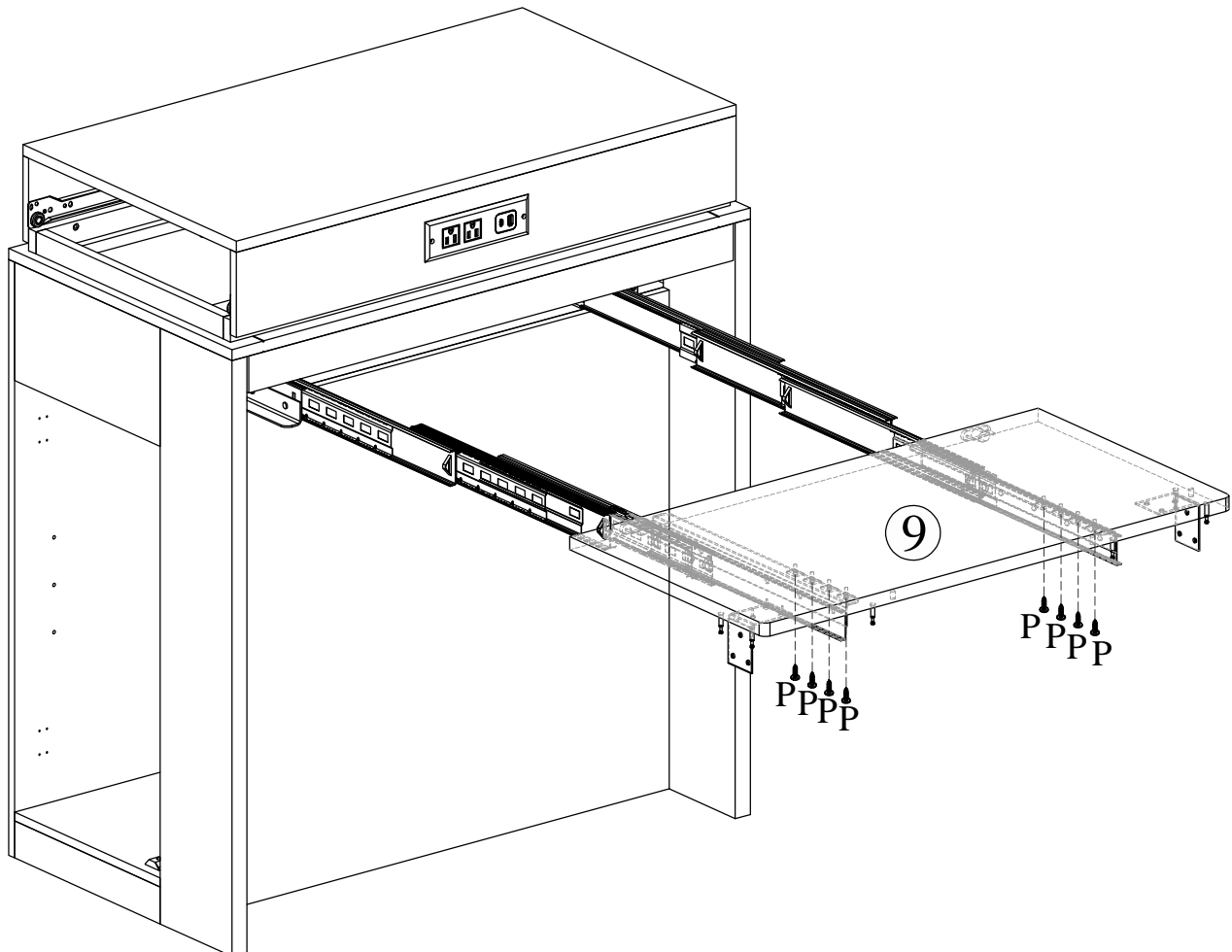
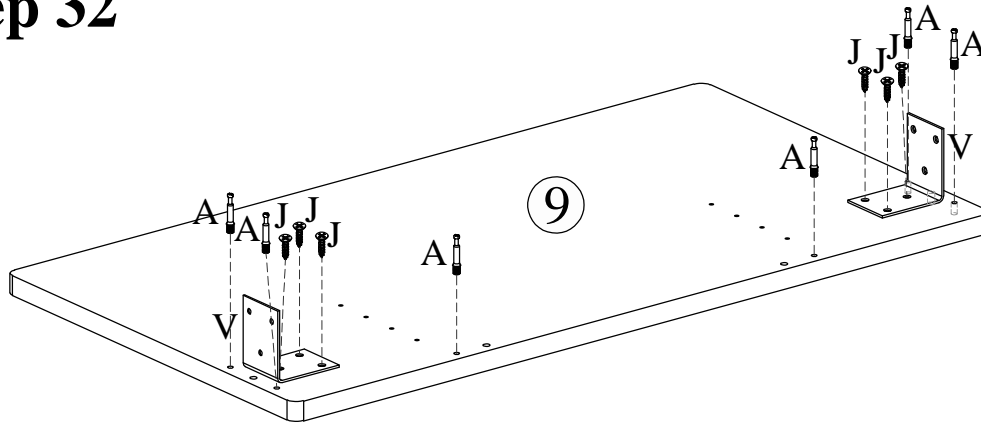

# ASSEMBLY INSTRUCTION

## Item : N715P396292/N715P396293

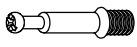
### Step 32



			
Ø6.5*35mm	Ø3*12mm	Ø5*16mm	
A X 6	J X 6	P X 8	V X 2

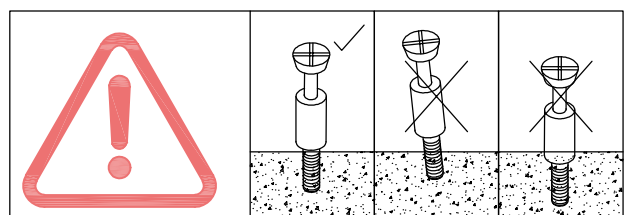

# ASSEMBLY INSTRUCTION

## Item : N715P396292/N715P396293

### Step 33

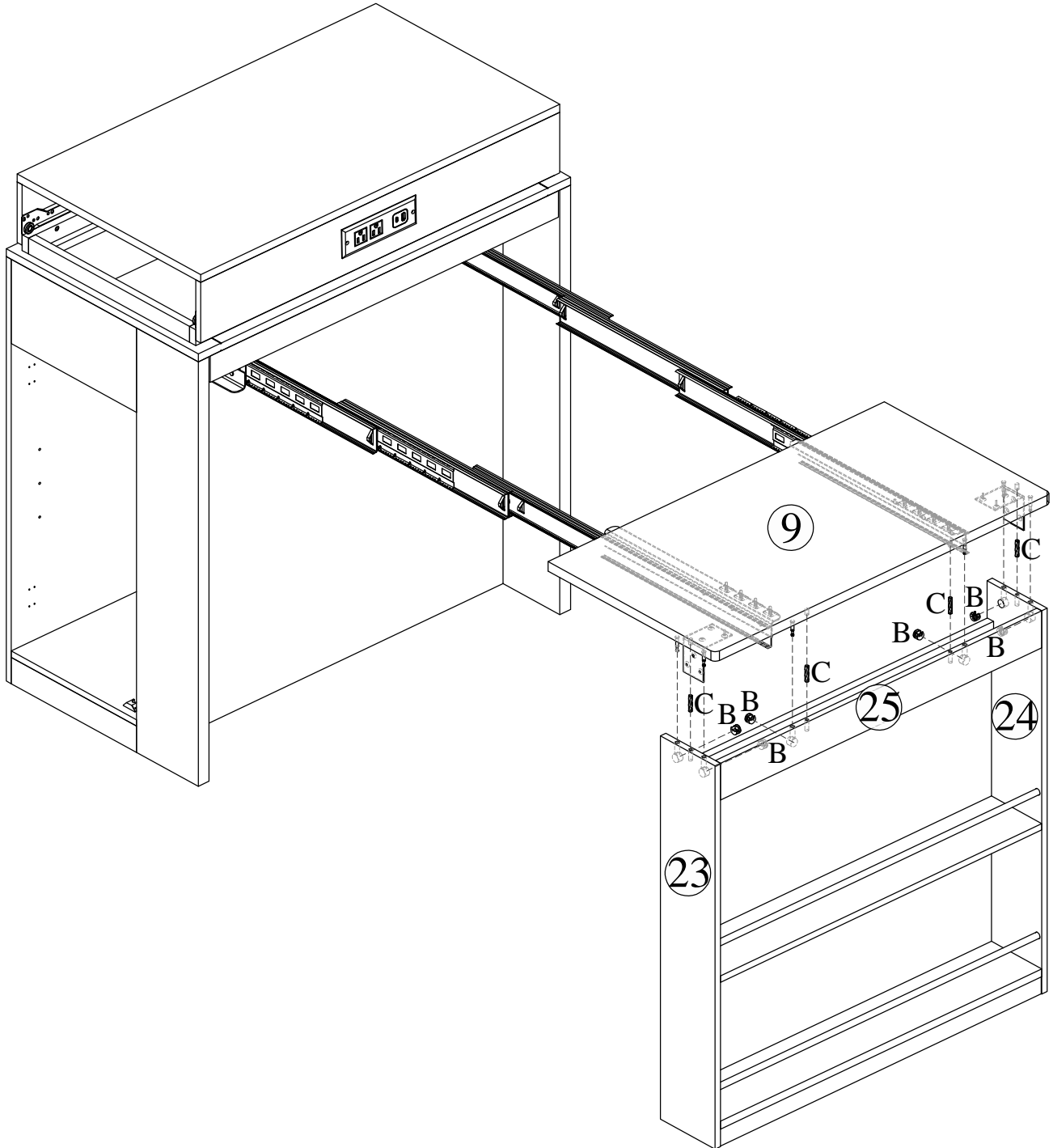

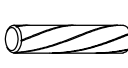
	
Ø15*9mm	Ø6*30mm
B X 6	C X 4

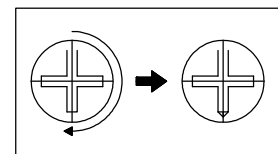

Lock Minifix cap clockwise

# ASSEMBLY INSTRUCTION

Item : N715P396292/N715P396293

## Step 34

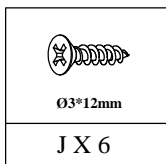
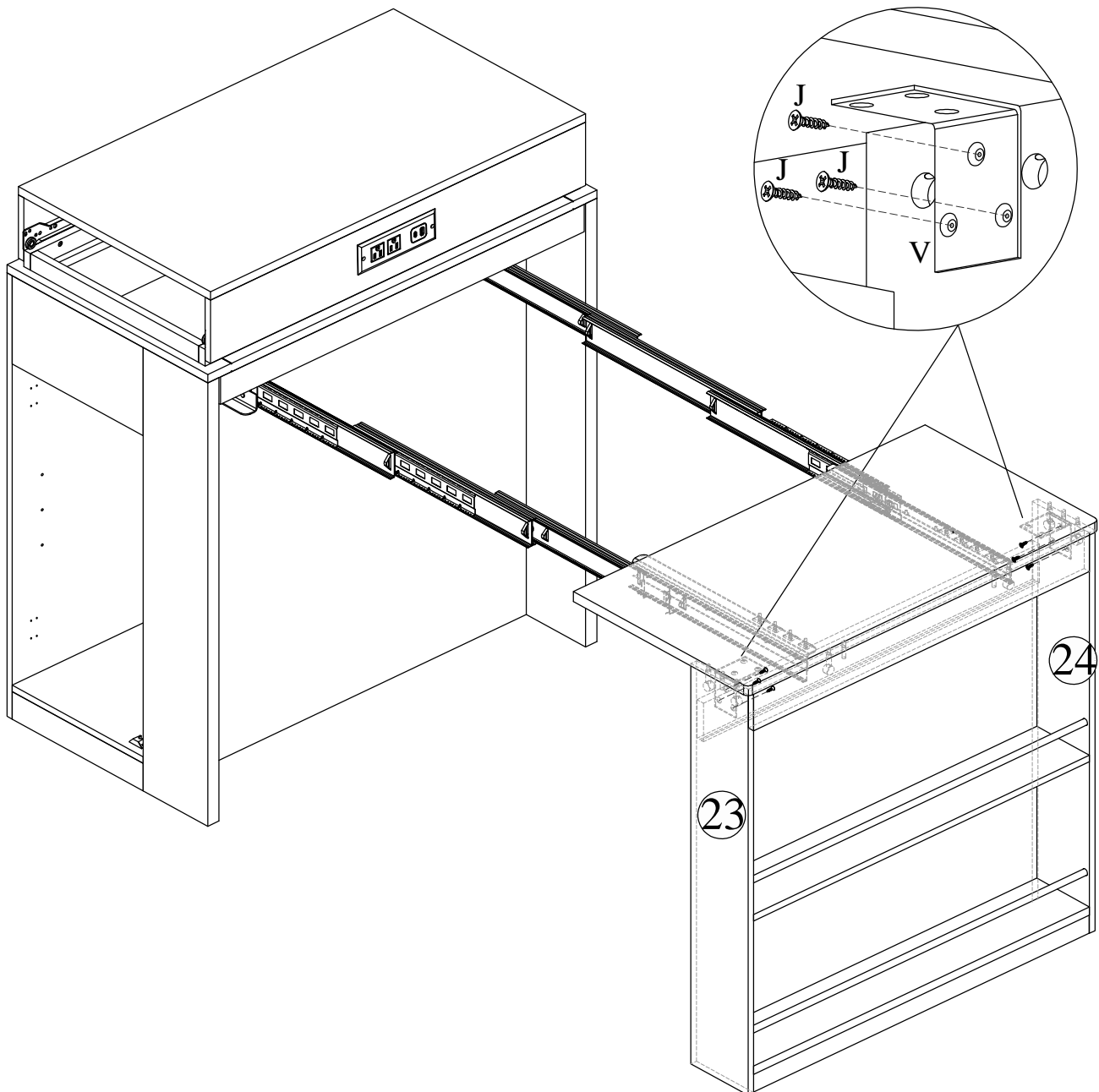



# ASSEMBLY INSTRUCTION

Item : N715P396292/N715P396293

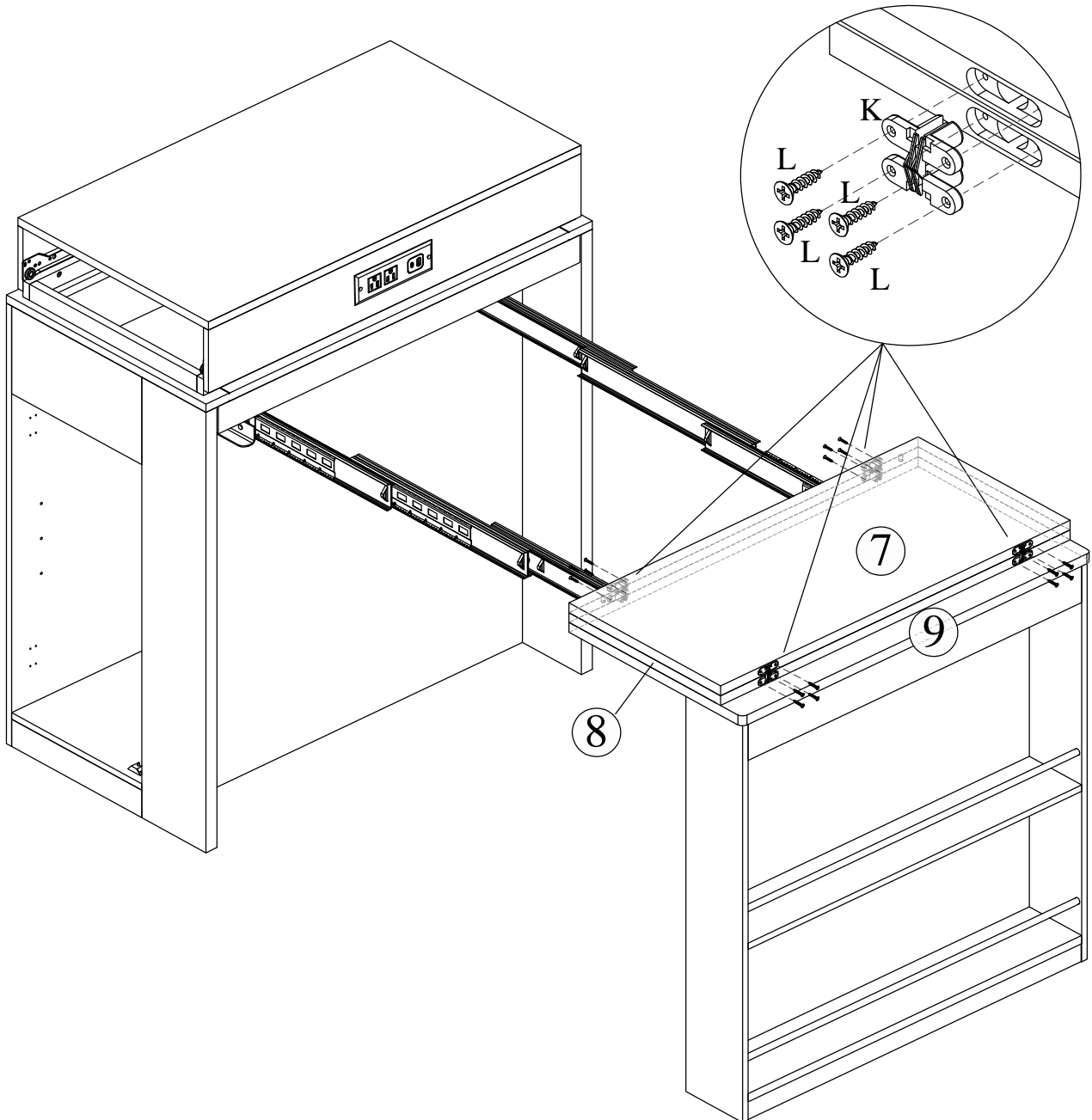
## Step 35



	
K X 4	04*19mm L X 16

# ASSEMBLY INSTRUCTION

Item : N715P396292/N715P396293

---

## Step 36

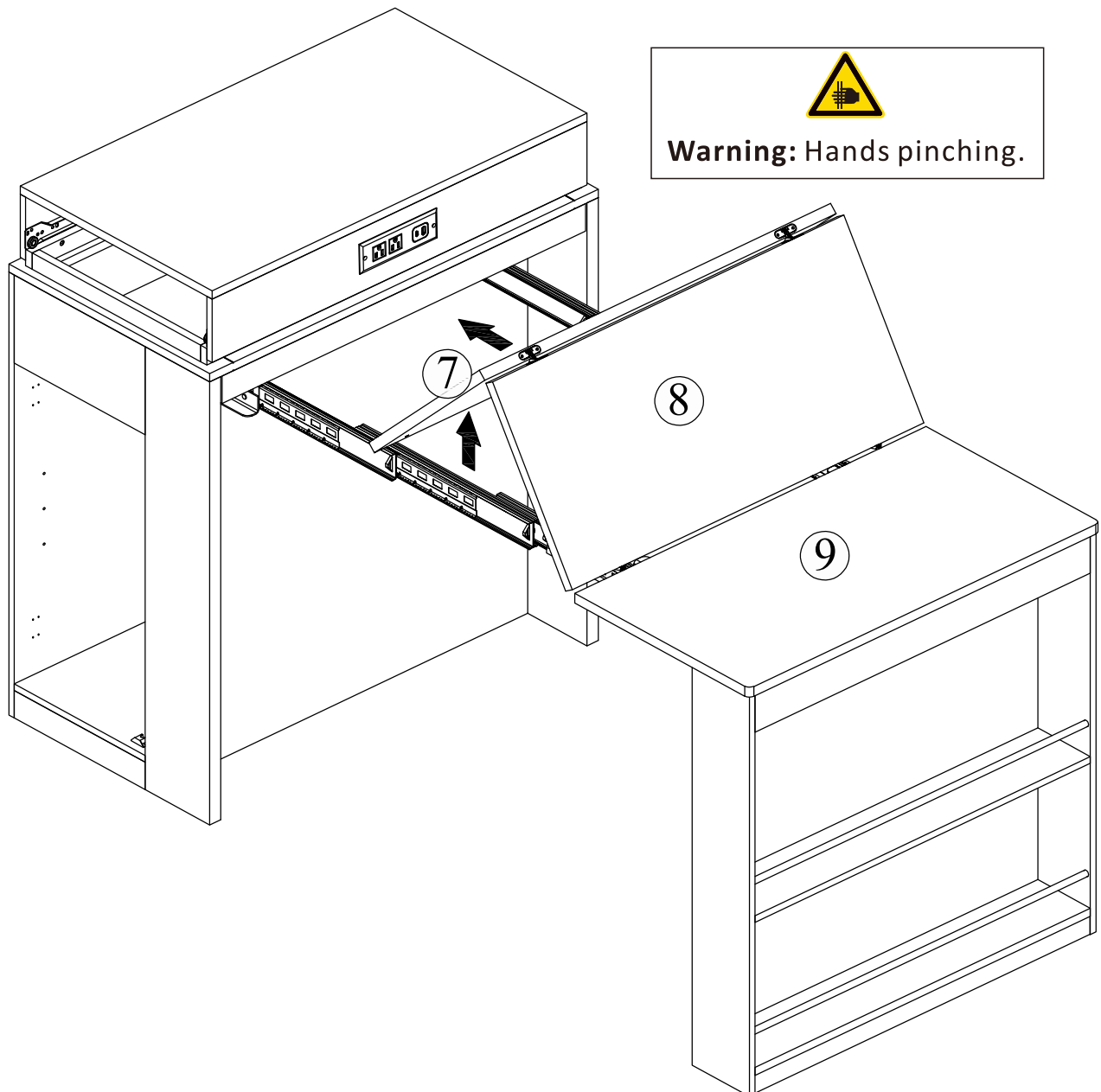

# ASSEMBLY INSTRUCTION

Item : N715P396292/N715P396293

---

## Step 37

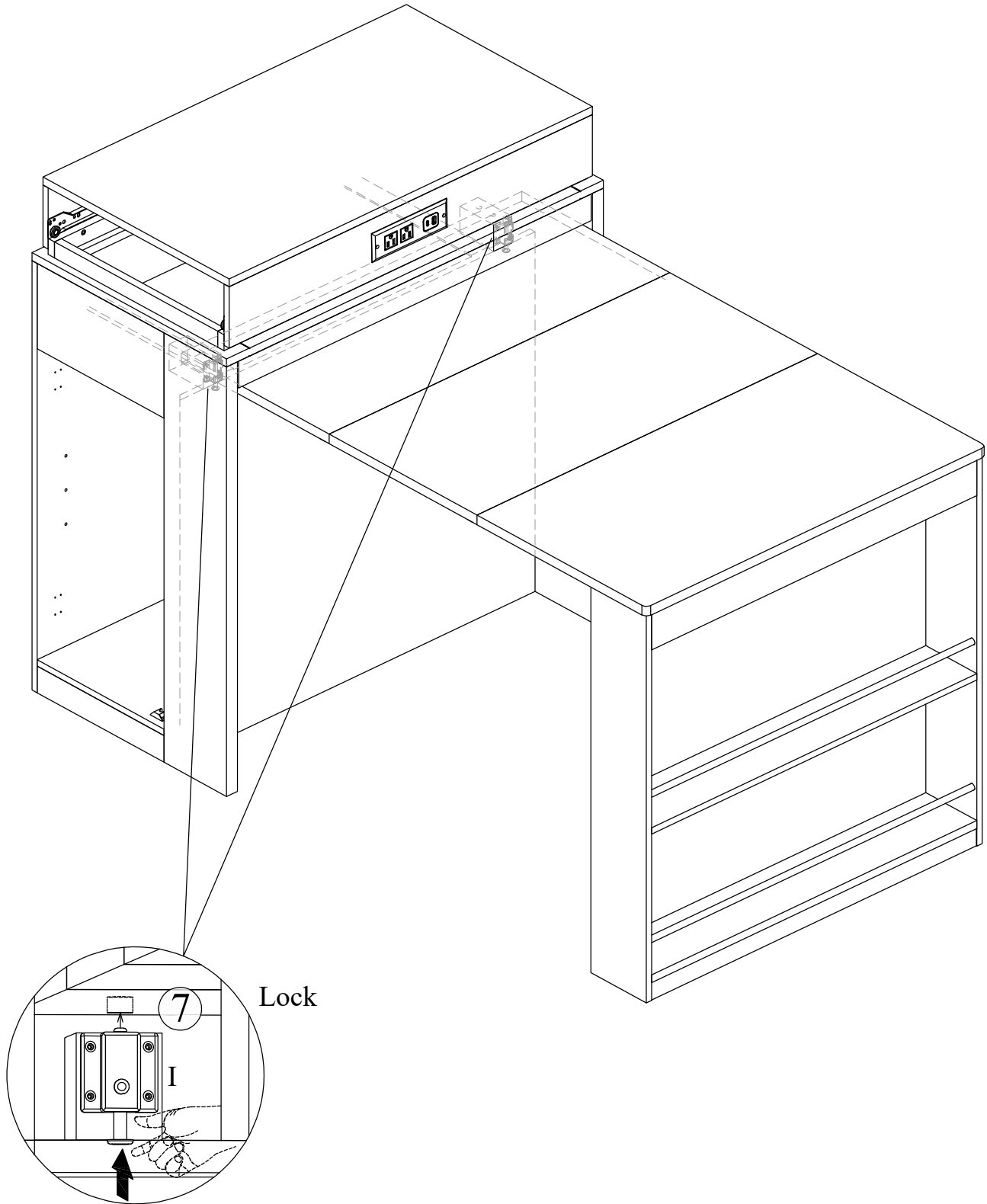

# ASSEMBLY INSTRUCTION

Item : N715P396292/N715P396293

## Step 38

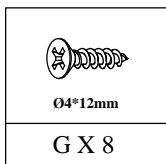
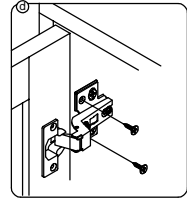
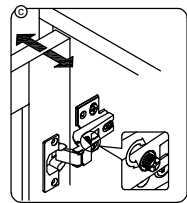
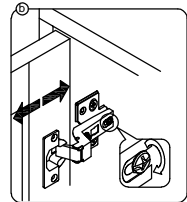
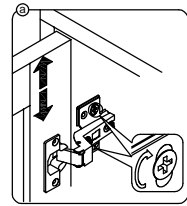
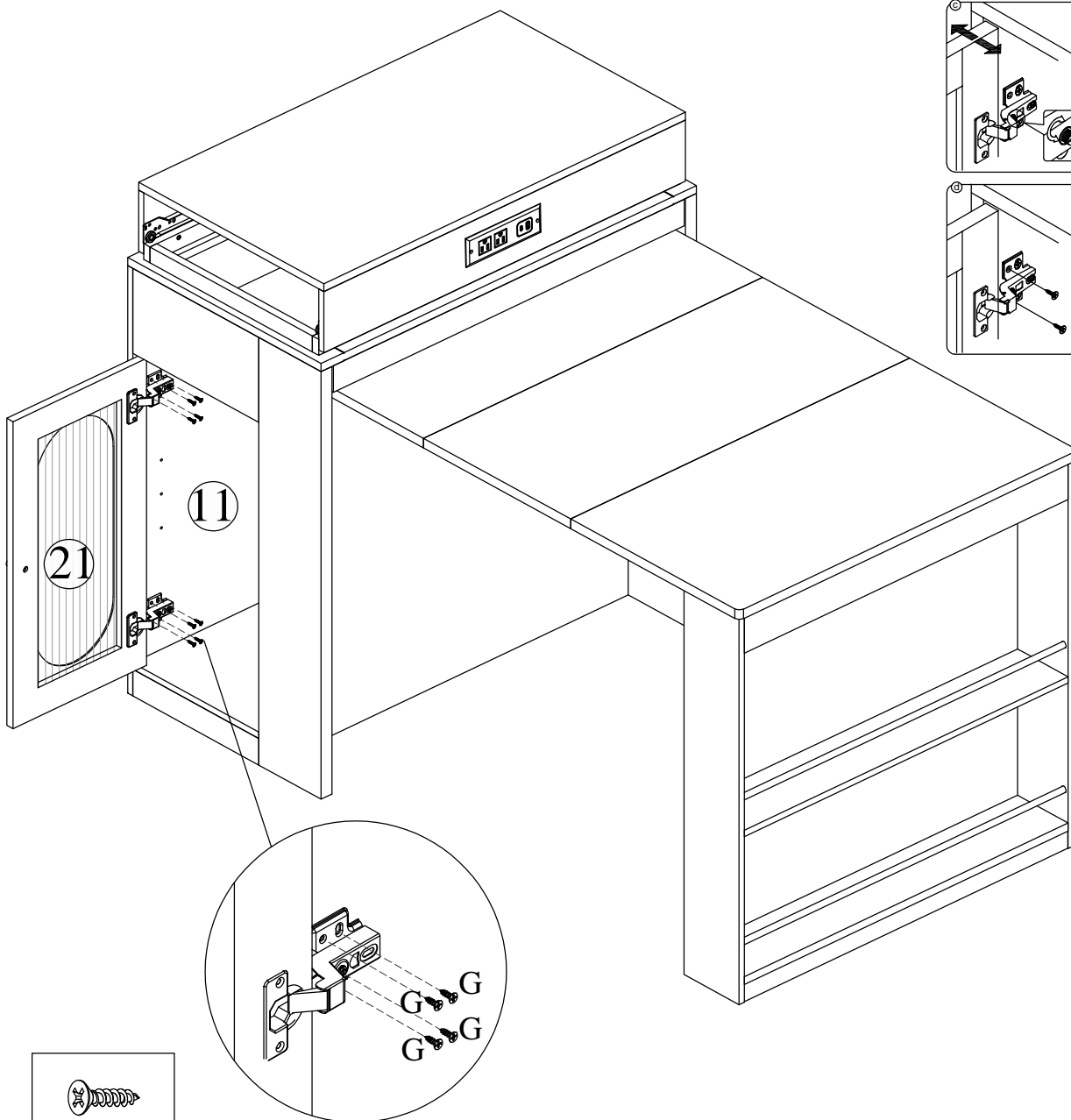

# ASSEMBLY INSTRUCTION

Item : N715P396292/N715P396293

## Step 39

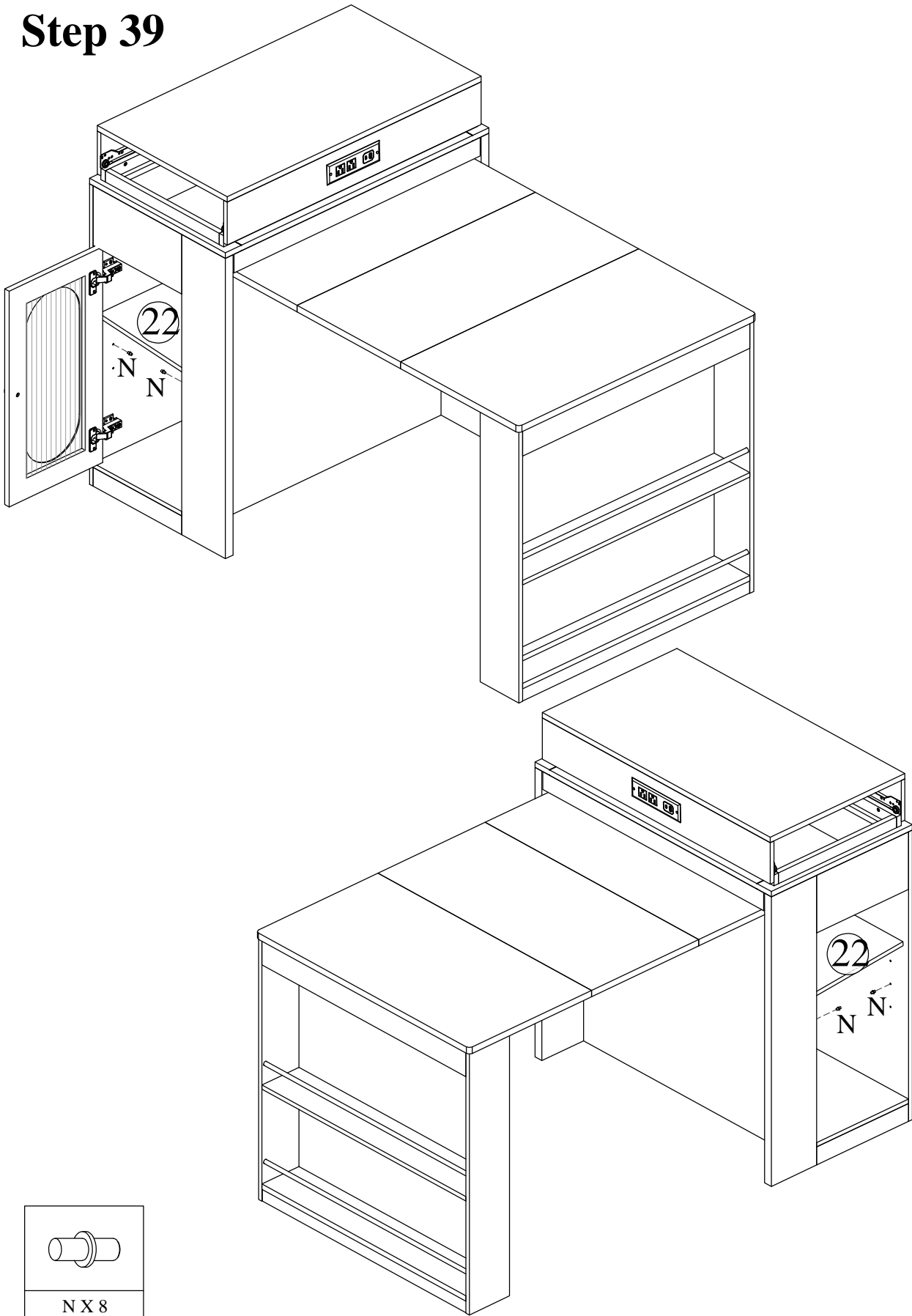

# ASSEMBLY INSTRUCTION

Item : N715P396292/N715P396293

---

## Step 40

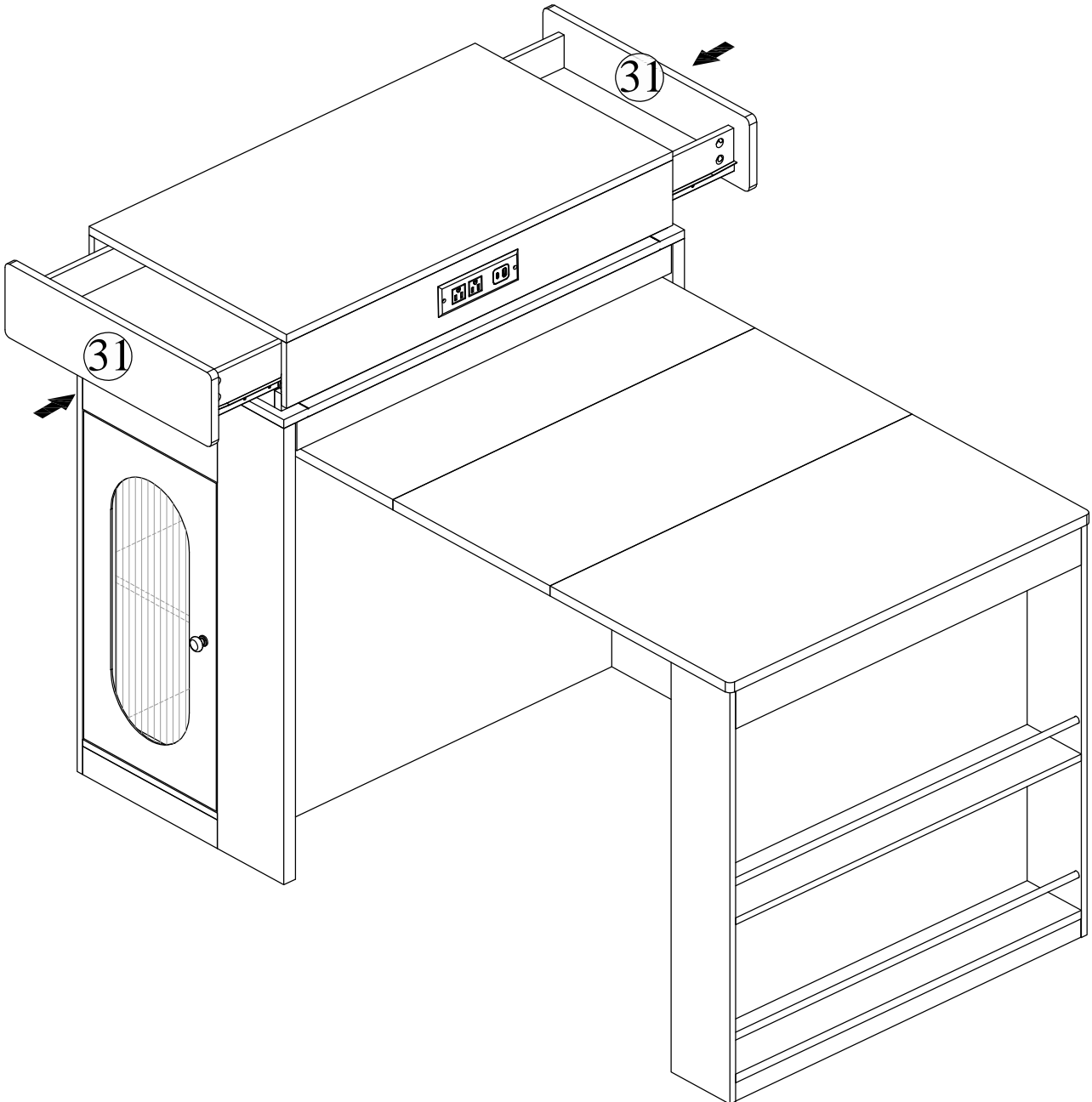

# ASSEMBLY INSTRUCTION

## Item : N715P396292/N715P396293

### Step 41

Lift up the front bar (Panel 14) before closing the table

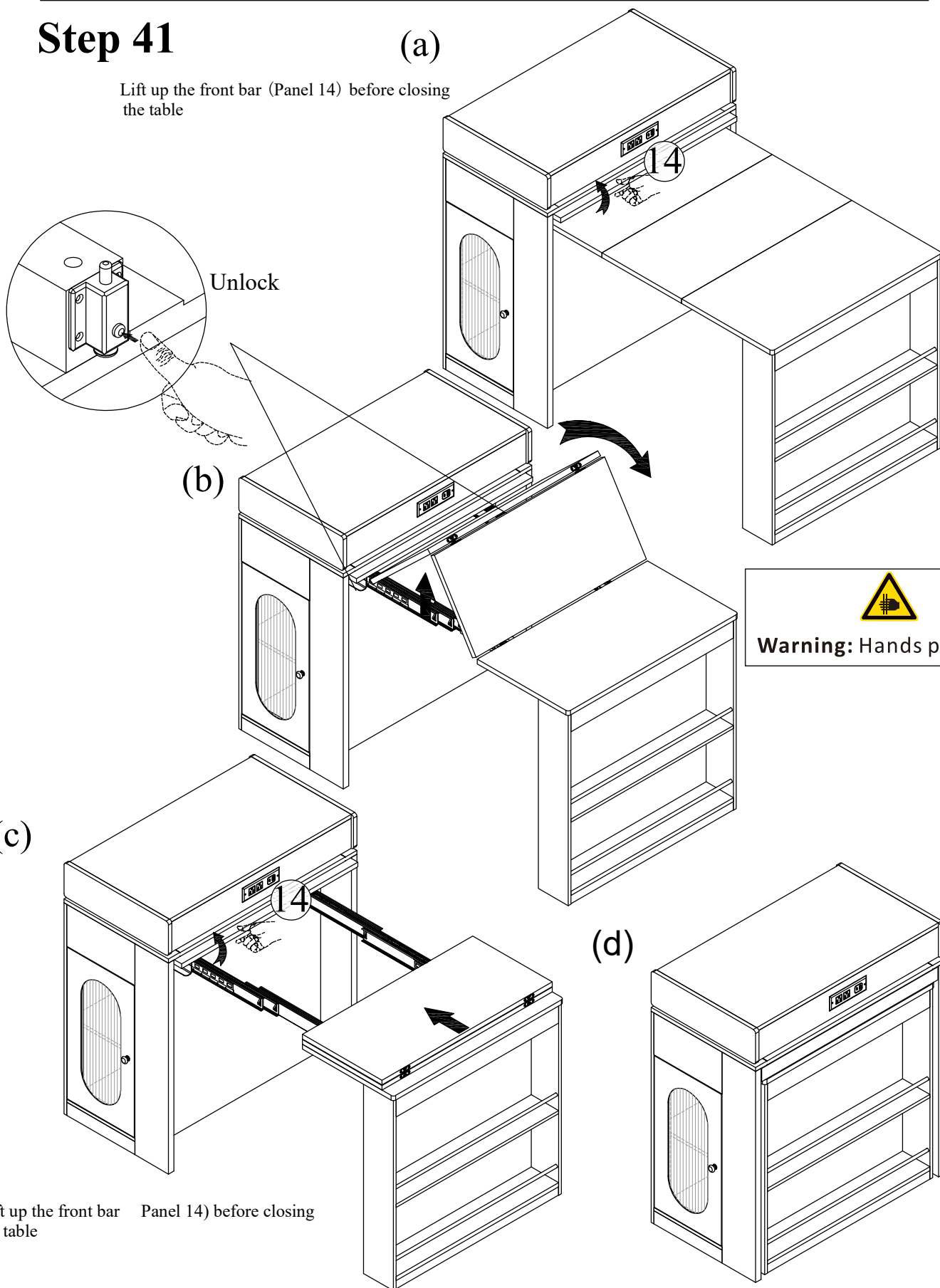

Lift up the front bar (Panel 14) before closing the table