

# ASSEMBLY INSTRUCTION

Caution: You must read this before you proceed

## Care & Maintenance

- Not for commercial use. For residential use only.
- Do not put hot items directly on furniture surface.
- Do not clean furniture with harsh cleansers or polish.
- Do not place furniture under direct sunlight.
- Do not place furniture near heating or cooling vents.
- Do not write on furniture without a padded barrier to protect the surface.
- Do not place furniture outside. For indoor use only.
- Stains may be removed with mild soap solution and damp cloth.
- Children should not climb or jump on the furniture.
- Dust and pick-up spills using a clean, non-colored, lint-free cloth.

## **BED**

**N736P427755B / N736P427756B**  
**N736P427755N / N736P427756N**  
**N736P427757B / N736P427758B**  
**N736P427757N / N736P427758N**  
**N736P427759B / N736P427759N**

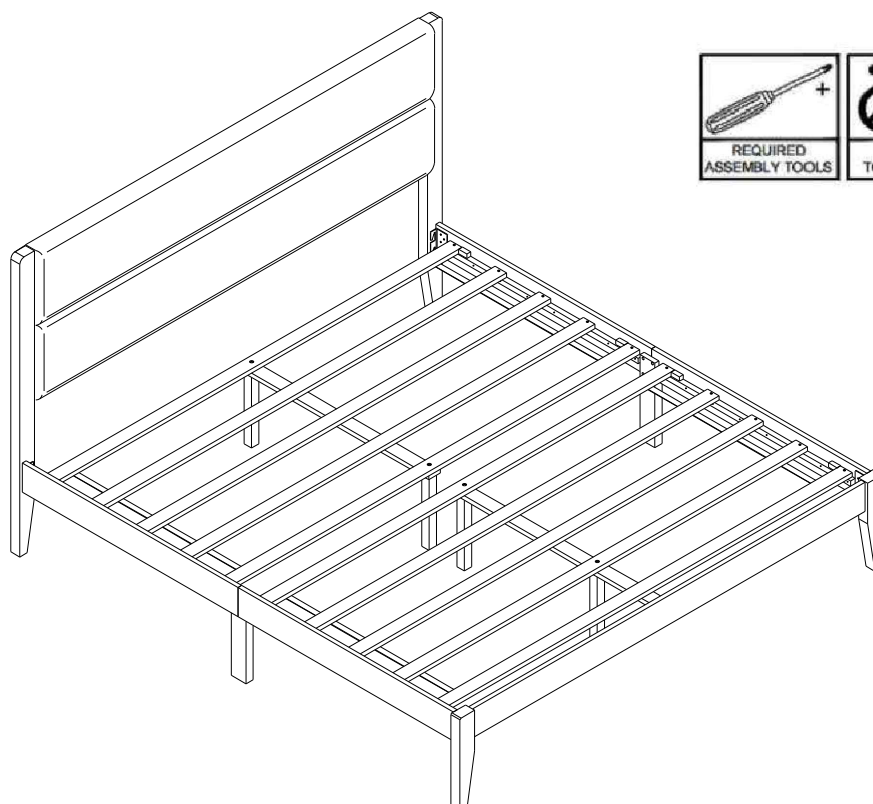



# WARNING

STRANGULATION HAZARD.

NEVER place bed near window where cords from blinds or drapes may strangle a child.

NEVER suspend strings over bed.

NEVER place item with a string, cord, or ribbon, such as hood strings or pacifier cords, around a child's neck. These items may catch on bed parts.

ALWAYS follow assembly instructions.



# WARNING

Not intended for children under the age of six. INFANTS HAVE DIED FROM BECOMING ENTRAPPED IN BEDS. Opening in and between bed parts can entrap the neck and head of a small child. NEVER use bed for child under the age of six.

The mattress must be appropriately sized for the bed. If the mattress is undersized, dangerous gaps can exist and a person can become entrapped or antangled in the frame and suffocate.

Note : This Bed is NOT a TOY.

Keep your child/children at bay during the assembly process.

THE BED is HEAVY.

To prevent injury to yourself or damage to the product a minimum of two adults are required whenever moving or lifting it.

## HARDWARE LIST

Code	Diagram	Description	QTY
①		Bolt (M6 X 50MM)	6
②		Bolt (M6 X 40MM)	8
③		Bolt (M6 X 35MM)	6
④		Bolt (M8 X 35MM)	8
⑤		Bolt (M8 X 20MM)	8
⑥		FLAT WASHER M8	14
⑦		SPRING WASHER M6	14
⑧		DOWEL (M8 X 30MM)	4
⑨		U WASHER (M6 X 25MM)	2
⑩		ADJUSTER	4
⑪		SCREW M4 X 30MM	21
⑫		ALLEN WRENCH BALL M4	1
⑬		ALLEN WRENCH M5	1
		SCREW DRIVER (Not provided)	

# PART LIST

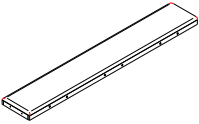
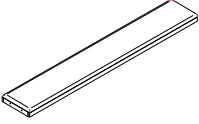
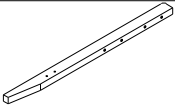
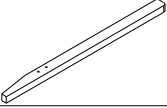
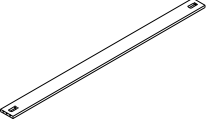
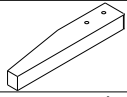
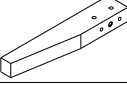
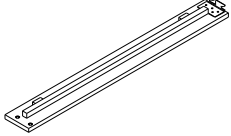
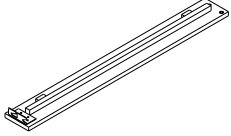
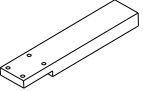
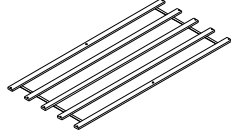
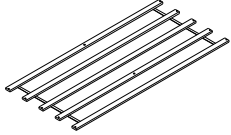
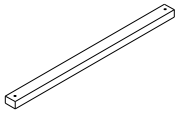
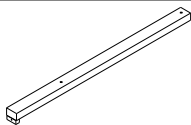
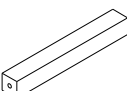
Label	Picture	Description	QTY
<b>A</b>		Upper Headboard	1
<b>B</b>		Lower Headboard	1
<b>C</b>		Headboard Post (Left)	1
<b>D</b>		Headboard Post (Right)	1
<b>E</b>		Footboard Rail	1
<b>F</b>		Footboard Post (Left)	1
<b>G</b>		Footboard Post (Right)	1
<b>H</b>		Side Rail (Left)	2
<b>I</b>		Side Rail (Right)	2
<b>J</b>		Side Rail Leg	2
<b>K</b>		Slat (Rear)	1
<b>L</b>		Slat (Front)	1
<b>M</b>		Center Support (Rear)	1
<b>N</b>		Center Support (Front)	1
<b>O</b>		Support Leg	4

# Assembly Preparation

Before Beginning Assembly:

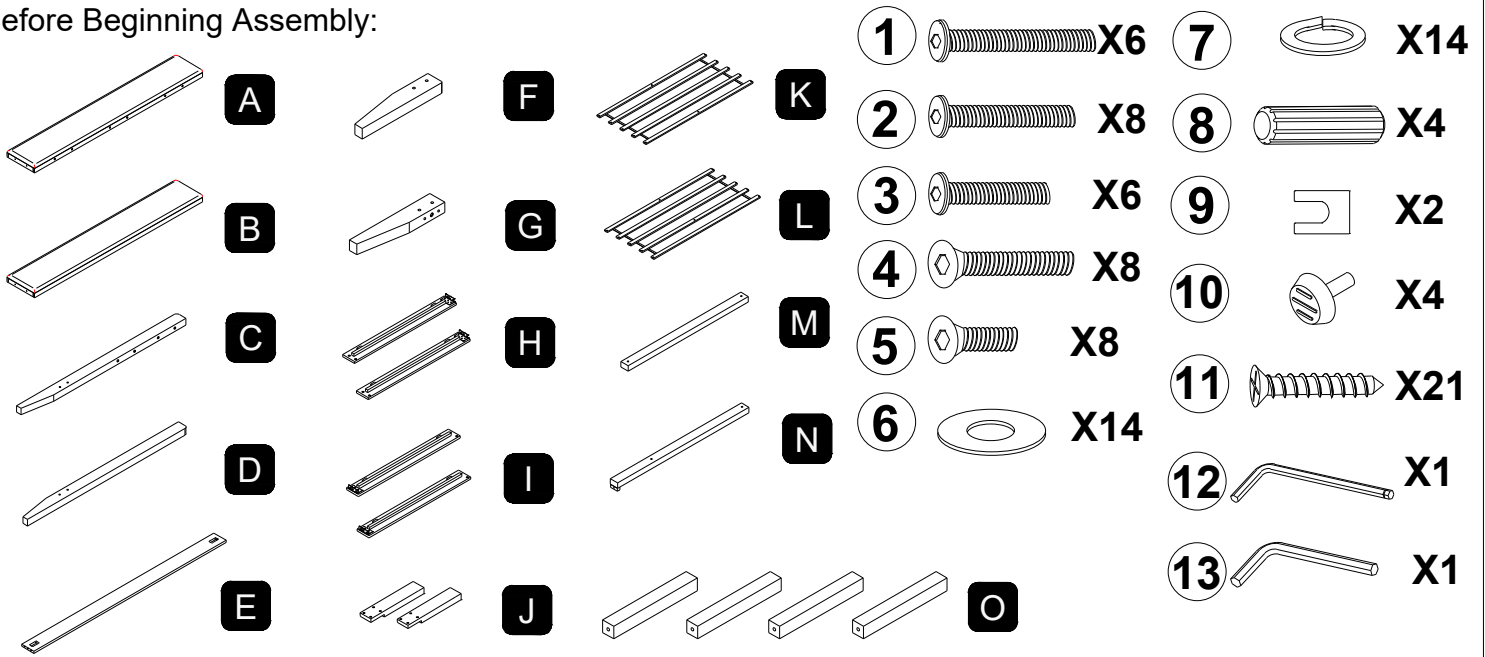

- Read instructions, cover to cover-



- Have 2 adults on hand for assembly-



- Do not assemble on flooring or carpet-



- Assemble on a clean non-marring surface (packing foam)-



- Save all packaging until finished-

## Assembly steps

Overview

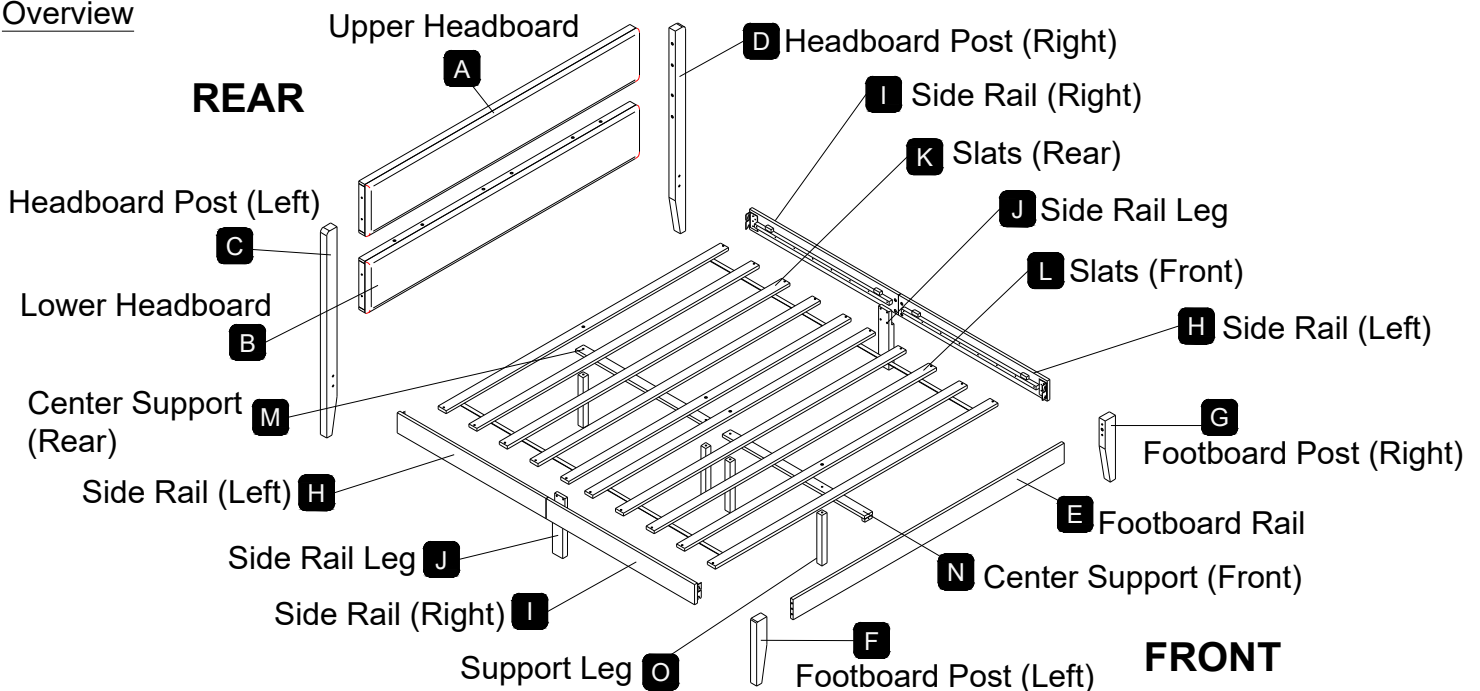

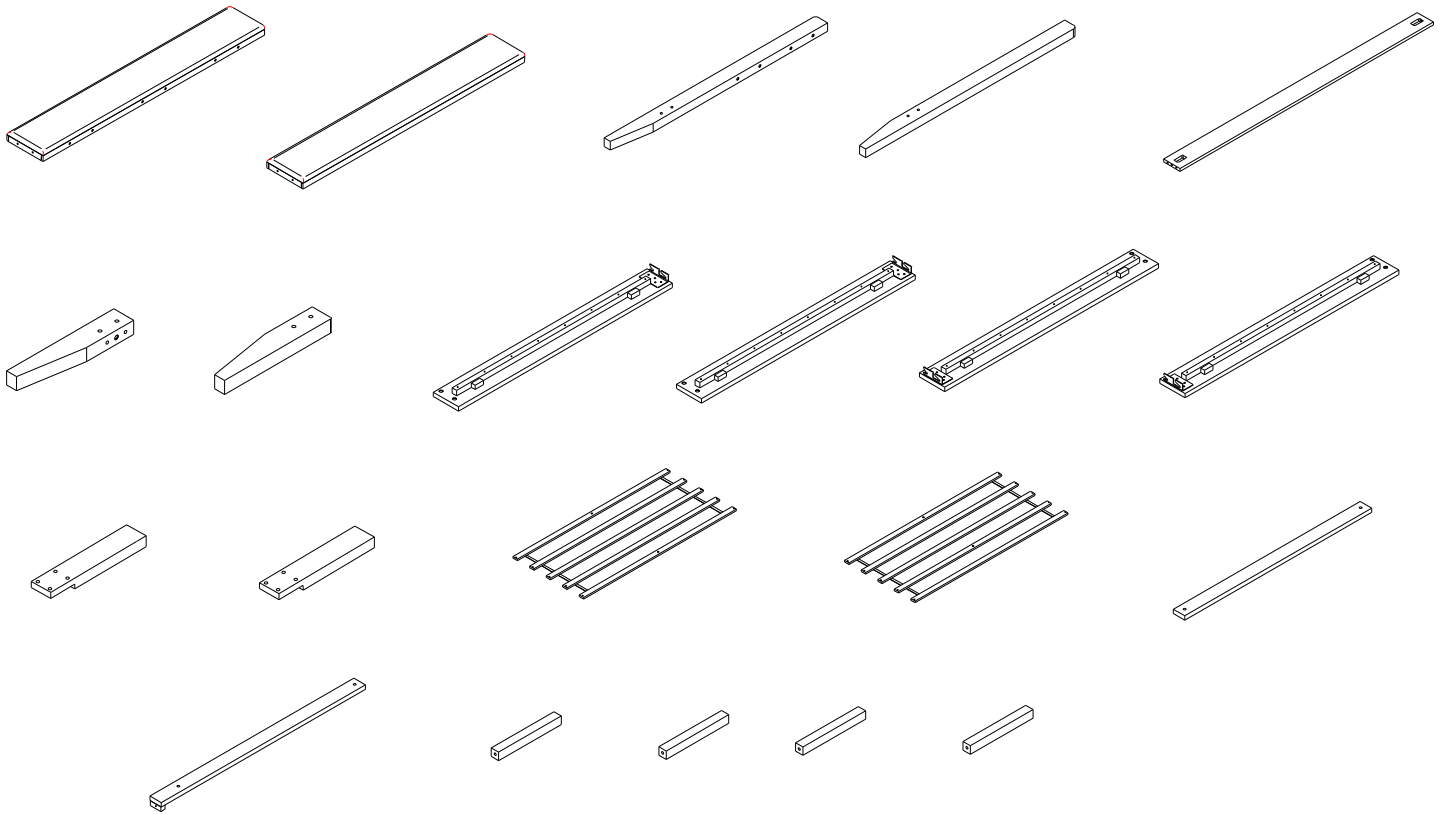

This Bed has multiple parts and may require up to 30 minutes to assemble. To give you an overview of the Bed parts, the above picture is provided to help you put the various parts into perspective. Please read through the instructions below to familiarise yourself with the parts and steps before assembly.

# STEP 1



Unpack and place all parts on a clean, non-marring surface.

# STEP 2

4		8
13		1

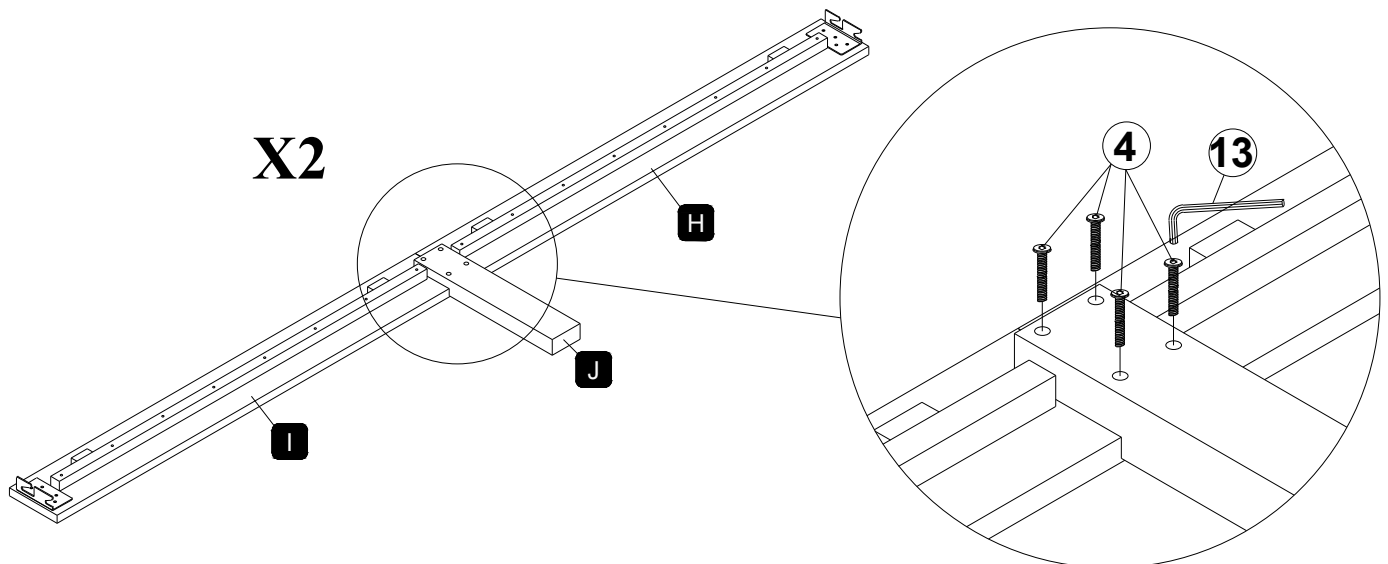

Place the Side Rail Leg (J) with its inner side face skywards onto a clean, soft surface to avoid any scratches or damages to the product. Align the Mounting Position of Side Rail Leg (J) into the Mounting Positions of Side Rail (H) and Side Rail (I) as shown above. Then, affix the Side Rail Leg (J) with Side Rail (H) and Side Rail (I) tighten it up by using Bolt (4), with Allen Wrench M5 (13).

# STEP 3

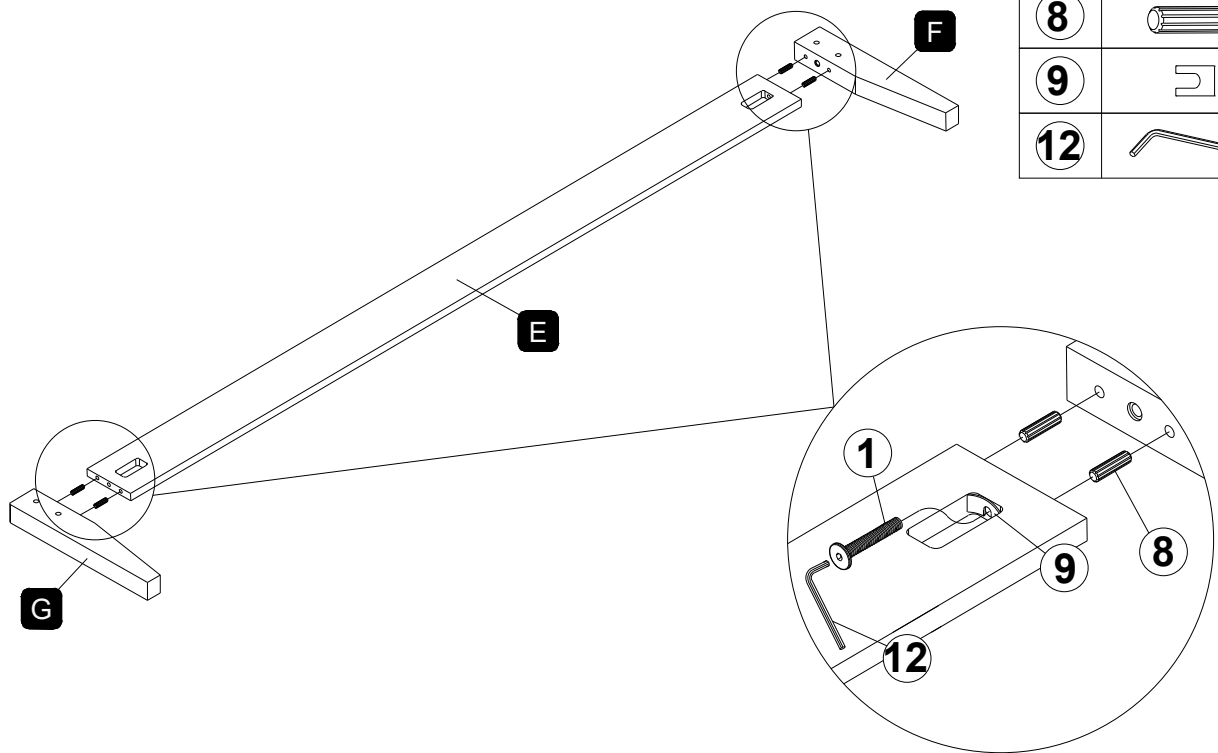

1		2
8		4
9		2
12		1

Place the Footboard (E), Footboard Post Left (F) and Footboard Post Right (G) onto a clean, soft surface to avoid any scratches or damages to the product as show in picture above. Align the Footboard Post Left (F) and Footboard Post Right (G) into the mounting positions of the Footboard (E) by using Dowel (8). Then, affix Footboard Post Left (F) and Footboard Post Right (G) to Footboard (E) by using Bolt (1), U Washer (9) tighten it up with Allen Wrench M4 (12).

# STEP 4

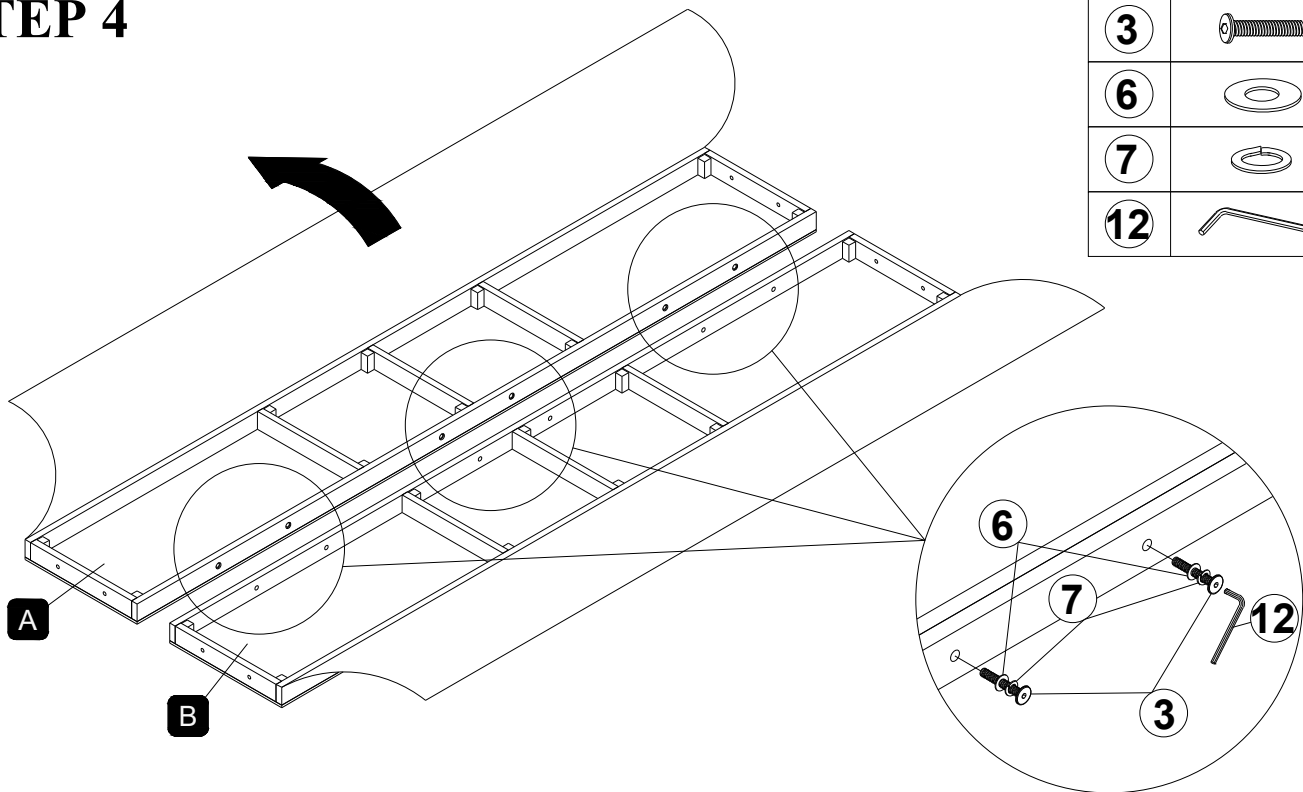

3		6
6		6
7		6
12		1

Place the Upper Headboard (A) and Lower Headboard (B) as show in picture above. Open the back black sheet and align the Upper Headboard (A) and Lower Headboard (B) into the mounting positions. Then, affix Upper Headboard (A) and Lower Headboard (B) by using Bolt (3), Flat Washer (6), Spring Washer (7) with Allen Wrench M5 (12).

**DO NOT FULLY TIGHTEN UNTIL THIS STEP COMPLETED.**

# STEP 5

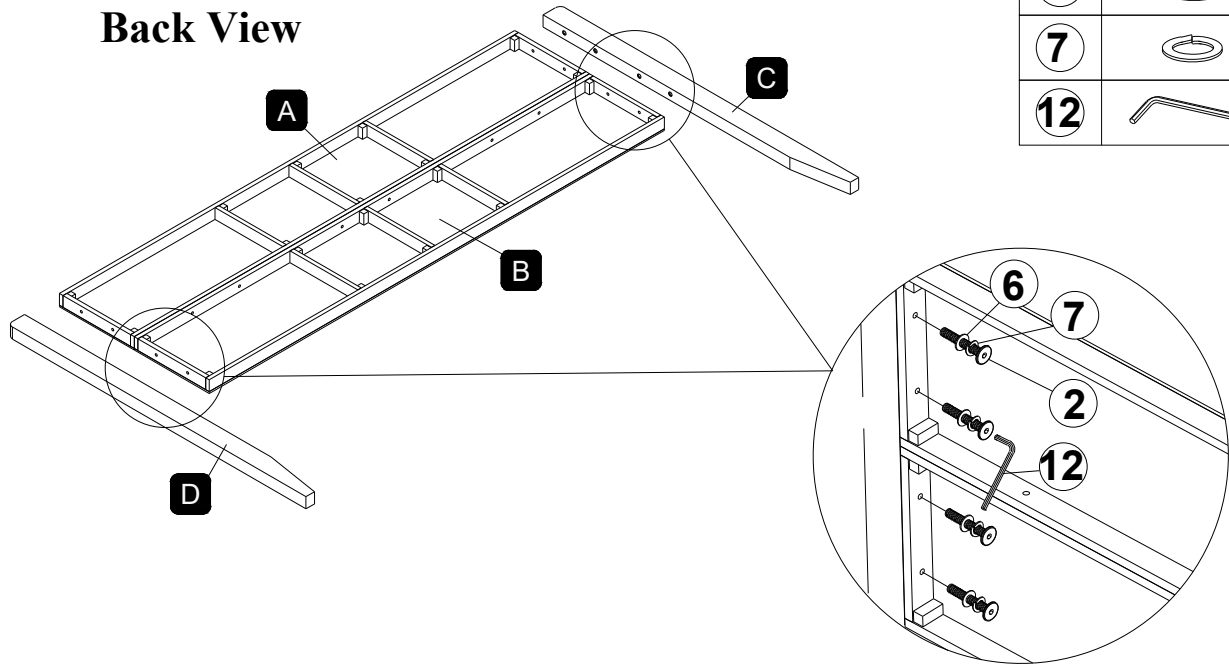

Place the Upper Headboard (A) and Lower Headboard (B) as show in picture above. Align the Headboard Leg L (C) and Headboard Leg R (D) into the mounting positions in the Upper Headboard (A) and Lower Headboard (B). Then, affix Headboard Leg L (C) and Headboard Leg R (D) to Headboard (A) and (B) by using Bolt (2), Flat Washer (6), Spring Washer (7) with Allen Wrench M5 (12). **DO NOT FULLY TIGHTEN UNTIL THIS STEP COMPLETED.**

# STEP 6

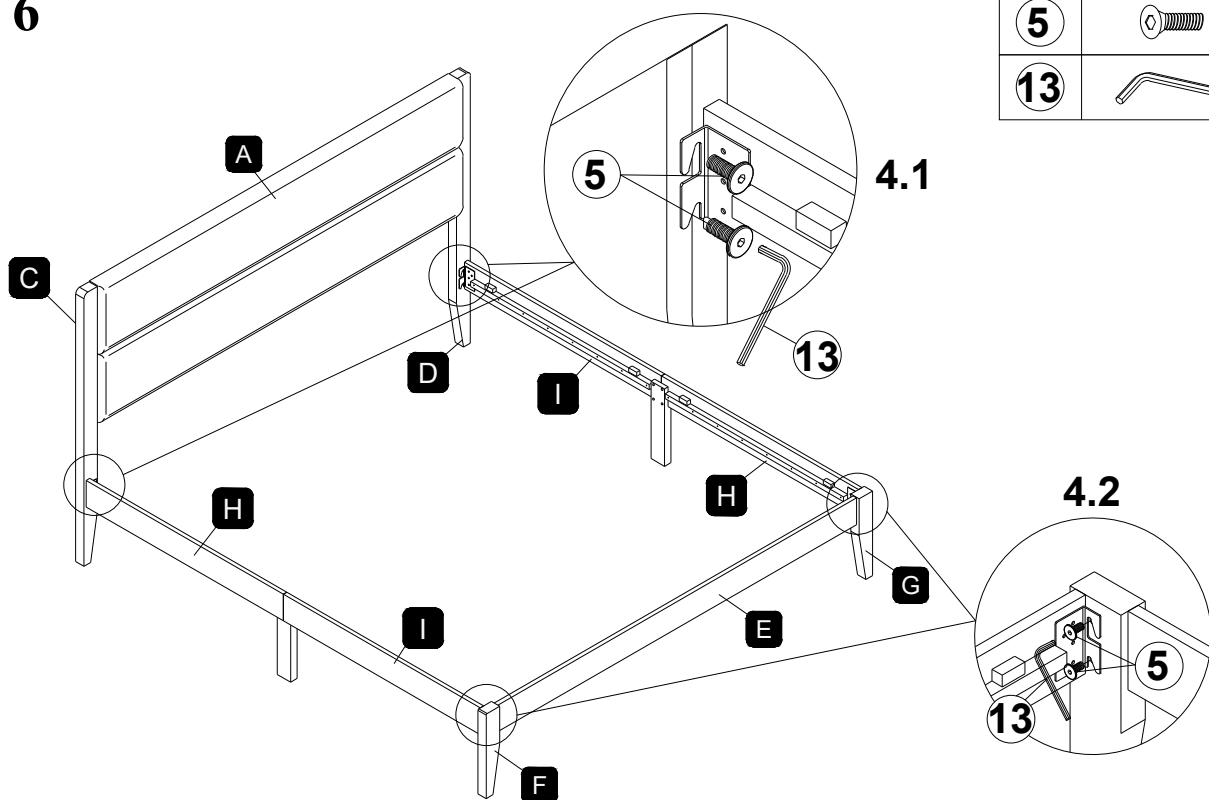

With the help from you partner, stand the assembled headboard (A) standing as shown in picture above

4.1: Attach the assembled side rail (H & I) to the assembled headboard (A & B) by using Bolt (5) with Allen Wrench M5 (13).

4.2: Attach the Footboard (F & G) to the assembled Side Rail (H & I) by using Bolt (5) with Allen Wrench M5 (13). **DO NOT FULLY TIGHTEN UNTIL THIS STEP COMPLETED.**

# STEP 7

10



4

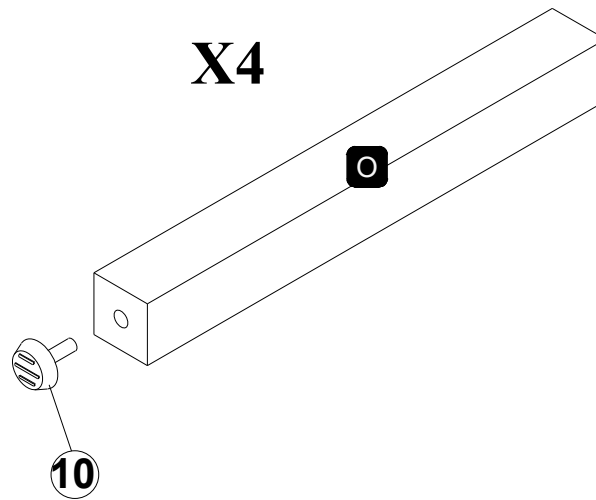

Align and attach the Adjuster (10) to the Support Leg (O).

# STEP 8

1



4

12



1

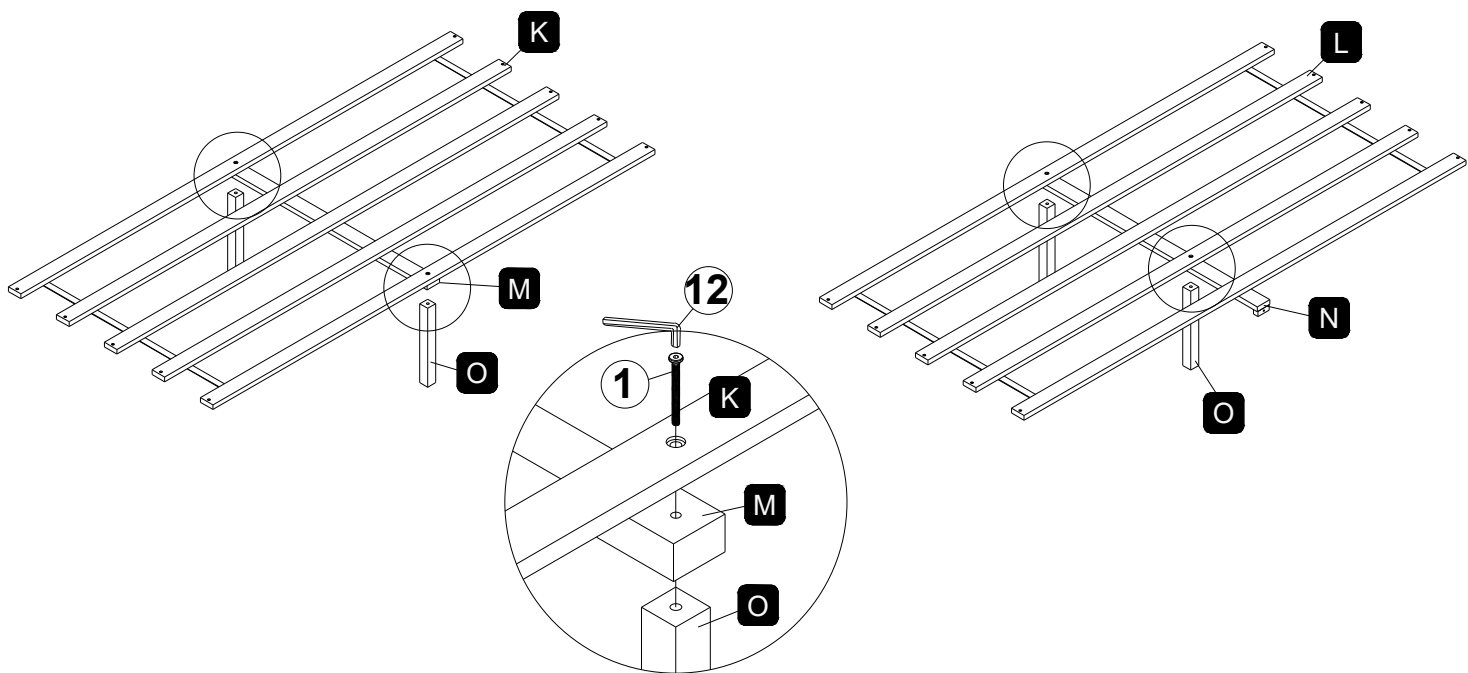

Align the Mounting Position on the Center Support (Rear) (M) to the Support Leg (O) and the Slats (Rear) (K), attach the Slats (Rear) (K) and the Center Support (Rear) (M) to the Support Leg (O) and by using Bolt (1) tighten it up with Allen Wrench M4 (12). Process the same step to attach the Slats (Front) (L) and the Center Support (Front) (N) to the Support Leg (O).

## STEP 9

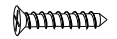
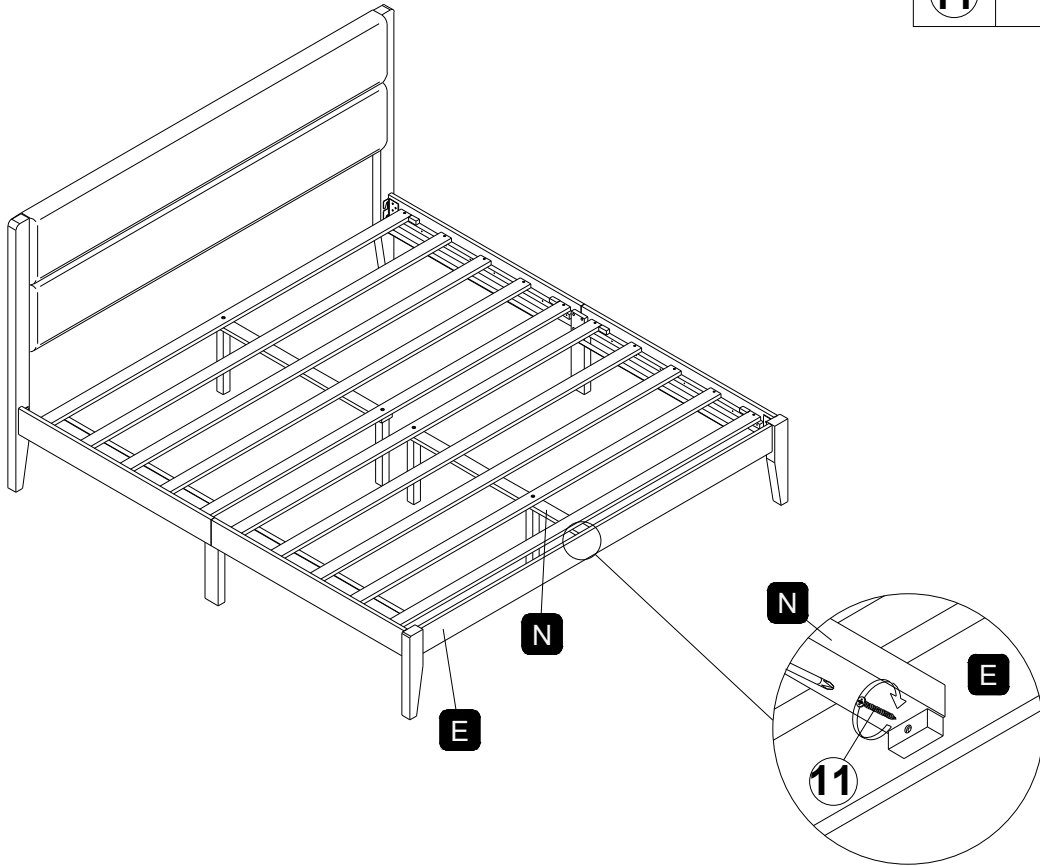
**11****1**

With the help from you partner, place the assembled Slats in the middle of the bed frame.

Attach the corner block under the Center Support (Front) (N) to the Footboard (E) by using Screws (11) and tighten it up.

SCREWDRIVER (Not Provided).

## STEP 10

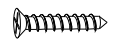
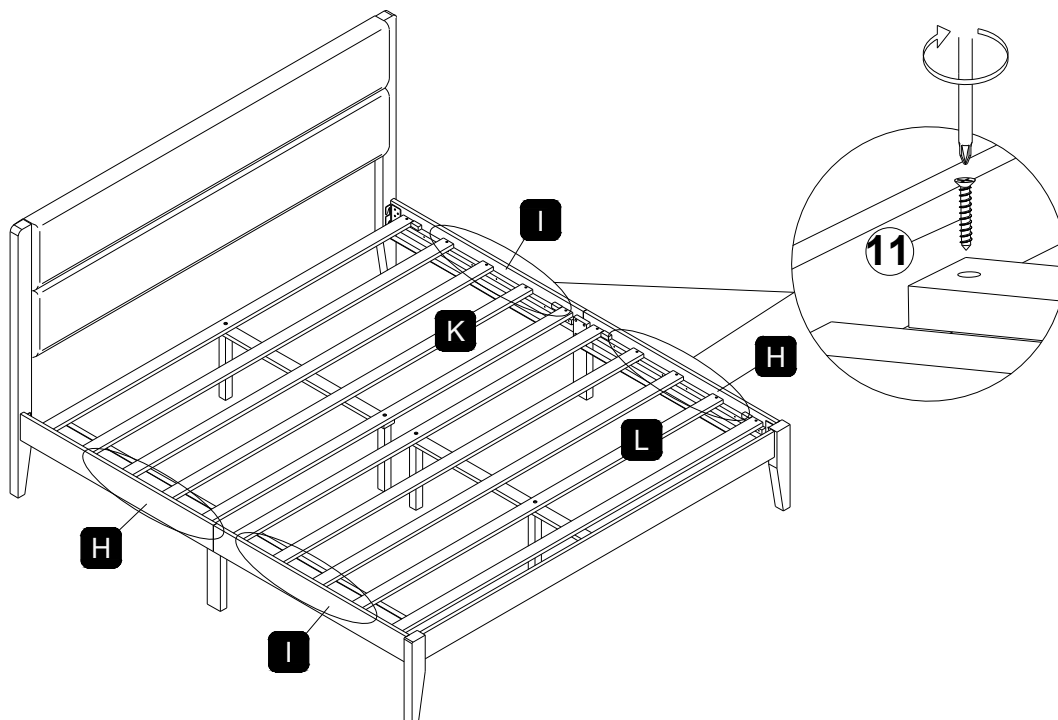
**11****20**

Attach all slats to the rail on Side Rail (H) and Side Rail (I) by using Screw (11) and tighten it up.

SCREWDRIVER (Not Provided).

# STEP 11

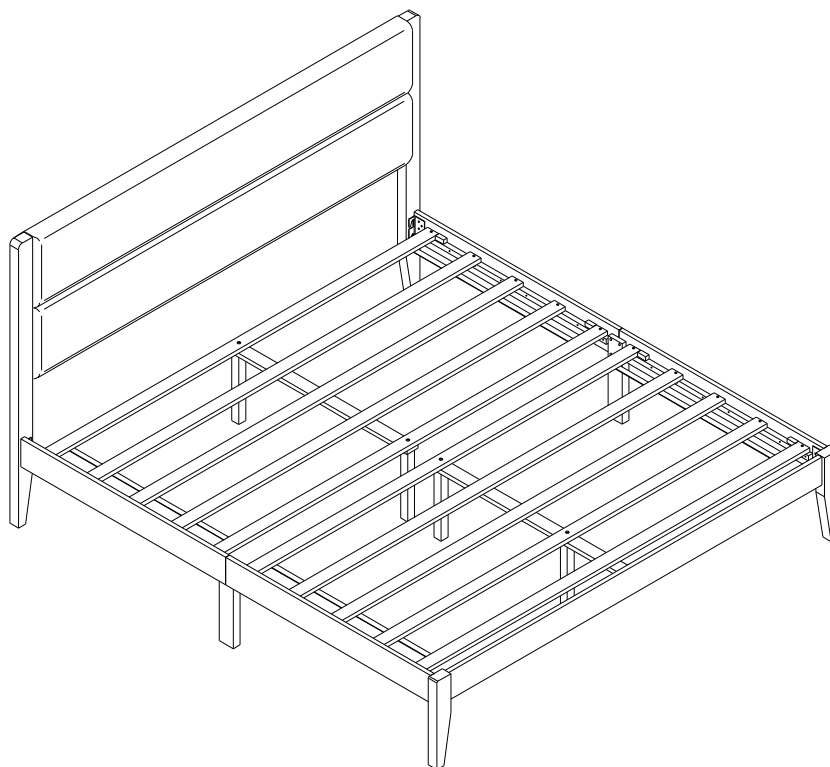

Place the Bed on a LEVEL SURFACE.  
Inspect it and make sure all parts are adequately connected.  
**Don't push too hard, shake on the bed.**  
This would help to align all the parts at all the joint areas.

**CAUTION 1: When tightening these screws, tighten sequentially.**  
**DO NOT tighten any screw fully and then towards the next one.**  
**This would cause the frame to warp.**  
**If there is still wobbles, loosen the screws and execute this same process. DO NOT tighten any screw fully and then towards the next one.**  
**WARNING!! IF BED IS NOT STABLE, IT COULD LEAD TO DAMAGING THE PRODUCT.**  
Ensure all screws are fully locked into position.  
The bed is ready to be used.

**CAUTION 2: This bed can only be used on a flat, level surface.**