

10-12FT Trampoline with Safety Net

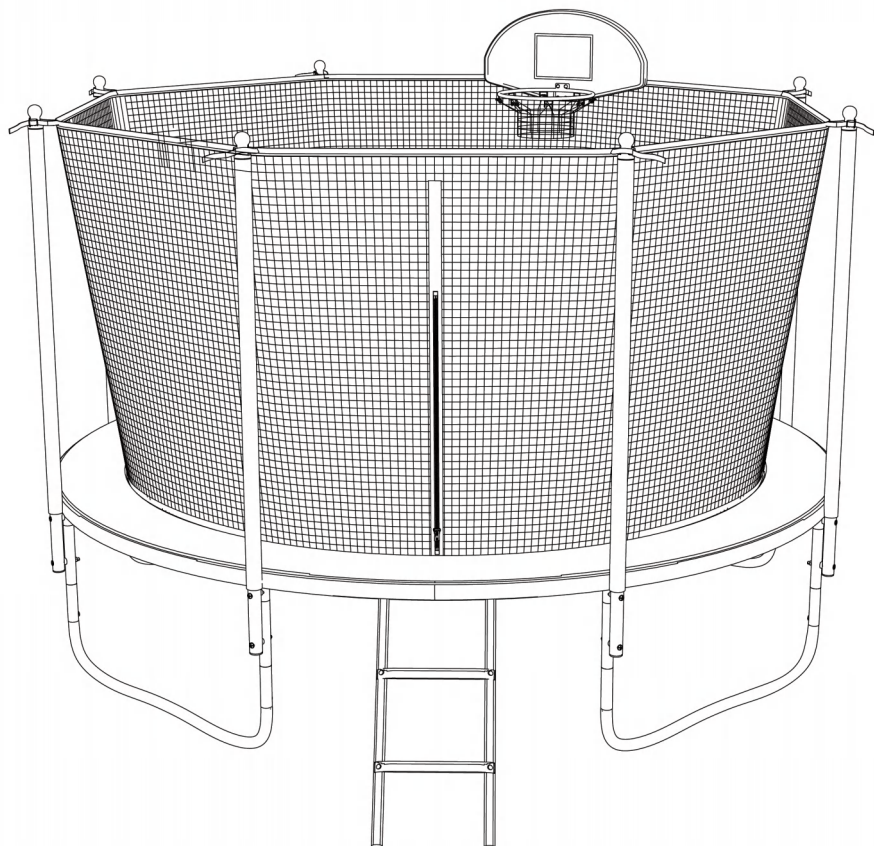

WARNING

The instructions are important for your safety. Please read them thoroughly before you assemble or use the trampoline. Retain this manual for future reference.

Do not use the trampoline without adult or knowledgeable supervision, regardless of your skill level or age.

A maximum of three to four children under the age of six can be accommodated at any one time. More than four children under the age of six will increase the risk of injury.

CONTENTS

Notice to User & Safety	2
Information	11
Trampoline Parts List	13
Assembly Instructions	15
Maintenance & Care	29

GENERAL SAFETY WARNING

BEFORE YOU BEGIN USING YOUR BIG TRAMPOLINE: Read and understand all this information provided to you in this manual. As with a physical sports and activities there is the risk of participants receiving an injury. To ensure your future enjoyment and the prevention of injury, be sure to follow appropriate safety rules and tips.

ALWAYS CONSULT A DOCTOR / PHYSICIAN BEFORE PERFORMING ANY KIND OF PHYSICAL ACTIVITY.

ALWAYS CHECK YOUR BIG TRAMPOLINE BEFORE USE. PAYING SPECIFIC ATTENTION TO ALL THE BOLTS JUMP MAT AND PADS POSITION. DON'T USE IF ANY PARTS ARE MISSING OR LOOK LIKE THEY SHOW WEAR AND TEAR

Using instructions

I . The weather environment and storage method of the trampoline

- Do not use when trampoline is wet or in windy conditions. In high winds, the trampoline may blow away. If windy weather is expected, move the trampoline to a shelter or remove it; Another method is to use ropes and stakes to tie the round outer part of the trampoline (top frame) to the ground, ropes and stakes; For safety, at least three straps should be used.
- Bounce only when the surface of the bed is dry. Wind or air movement should be calm to gentle. The trampoline must not be used in gusty or severe winds
- Bounce only when the surface of the bed is dry. Wind or air movement should be calm to gentle. The trampoline must not be used in gusty or severe winds
- Do not use the trampoline in heavy rain. Rain will make the jumper surface become very slippery, to avoid slipping and safety problems. If windy weather is expected, move the trampoline to shelter or remove it.

II .Trampoline installation, site and handling requirements



1. Please make sure at least 2 people install the trampoline.



2. Please install the trampoline on the flat and non-slippery ground.



3. Please install the springs in the X-shape order one by one as requested in the instructions.

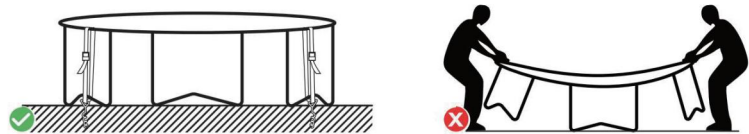

4. Please do not move or lift the trampoline during or after installation but use the tie down stakes kit to secure it.

III . Dress requirements when using the trampoline

- Wear clothing without draw lines, hooks, loops, or anything that can become entangled and cause entanglement or suffocation when using the trampoline/fence.
- When using this trampoline ensure appropriate clothing is worn, preferably sports wear and socks .NEVER WEAR SHOES ON THE MAT.
- It is recommended to remove glasses, watches, bracelets, necklaces, and other items that are easy to fall.

IV . Physicalex amination

- Always consult a doctor/physician before performing any kind of physical activity.
- Do not use the trampoline while under the influence of alcohol or drugs.

V . Other instructions for use

- Trampolines over 20 in. (51 cm) tall are not recommended for use by children under 6 years of age.
- If a trampoline ladder is used, the supervisor should remove it from the trampoline when leaving the area to prevent unsupervised access by children under 6 years of age.
- Do not attempt or allow somersaults. Serious injuries, paralysis, or death may result
- Use trampoline only with mature, knowledgeable supervision.
- Inspect before use. Keep frame padding in place.
- Climb on and off the trampoline. Do not use the trampoline as a springboard.
- Stop bounce by flexing knees as feet come in contact with the bed.
- Learn fundamental bounces and body positions thoroughly.
- Avoid bouncing too high. Maintain control.
- While keeping the head erect, focus eyes on the trampoline toward the perimeter.
- Bounce in the center of the bed.
- Avoid bouncing when tired.
- Secure the trampoline against unauthorized use.
- Keep objects away which could interfere with the performer.
- For equipment information, contact the manufacturer.
- For skill training information, contact a trainer certification organization.

⚠️ ADDITION SAFETY WARNING

- Stop exercising immediately should you feel unwell or if you feel pain in your joints and muscles. Dizziness is a sign of fatigue and you should stop bouncing and lay down on the ground should you feel dizzy.
- Please be warned that trampoline is spring based and will allow the user to jump to a greater height than that on the ground, so please bear this in mind and ensure that you are comfortable bouncing at low heights first.
- Proper assembly, care and maintenance of product, safety tips, warnings, and proper techniques for jumping on your trampoline are included in this manual for your safety and an extended product life span. A users and supervisors should therefore familiarize themselves with these instructions Anvoody who chooses to use the trampoline must be aware of their own limitations with regards to performing skills on this trampoline.
- The safety enclosure is there to prevent the user falling off the trampoline, and is not to be jumped into unnecessarily.
- Trampoline should be assembled on grass or BSI approved safety matting.

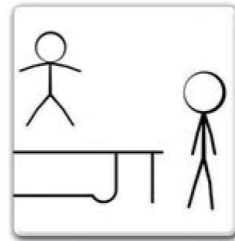
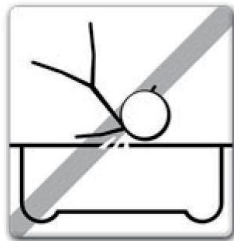

Use of Trampoline

- Inspect the trampoline enclosure before each use. Make sure the barrier and the enclosure support (frame) padding is correctly and securely positioned, Replace any worn, defective, or missing parts.
- Users may become entangled in or strangled by loose cords or in gaps between trampoline and enclosure.
- Keep enclosure tightly fastened to the trampoline in accordance with the manufacturer's instructions. Failure to properly assemble and maintain a tight, secure trampoline/ enclosure boundary may result in serious injury, strangulation, or death.
- Do not attempt to jump over the barrier.
- Do not intentionally rebound off the barrier.
- Do not hang from, kick, cut, or climb on the barrier.
- Wear clothing free of drawstrings, hooks, loops or anything that could get caught while using the trampoline/ enclosure and result in entanglement or strangulation, or both.
- Do not attach anything to the barrier that is not a manufacturer-approved accessory or part of the enclosure system.
- Enter and exit the enclosure only at the enclosure door or barrier opening designated for that purpose.

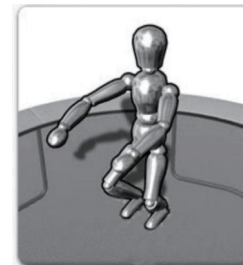

BEFORE YOU TRY TO JUMP TOO HIGH the technique for stopping should be learned as this will help prevent injury should you feel you are jumping out of control.

As the user lands on the mat knees should be bent so that they stop and absorb the spring in the mat. The position is shown in the image to the left. Arms are held out for increased level of balance.

This skill is used when the trampoline user wishes to stop bouncing on the trampoline due to fatigue, loss of control, etc.



SOMERSAULTS (FLIPS): DO NOT PERFORM somersaults of any type (backwards or forwards) on this trampoline. If you make a mistake when trying to perform a somersault, you could land on your head or neck. This will increase your chances of your neck or back being broken, which could result in death or paralysis.



FOREIGN OBJECTS : DO NOT use the trampoline if there are pets ,other people or any objects underneath the trampoline .This will increase the chances of an injury occurring ,DO NOT hold any foreign objects in your hand and DO NOT place any objects on the trampoline while in use. DO NOT place the trampoline under over- hanging objects like tree branches,wires, etc as these will increase your chances of being injured.



POOR MAINTENANCE OF TRAMPOLINE: A trampoline in, poor condition will increase your risk of being injured. Please inspect the trampoline before each use for bent steel tubes, torn mat, loose or broken springs and overall stability of the trampoline.



WEATHER CONDITIONS: Please be aware of the weather conditions when using the trampoline. If the mat of the trampoline is wet, the user could slip and injure himself herself .If it is too windy, the user could lose control.



RESTRICTING ACCESS: When the trampoline is not in use, always store the access ladder in a secure place so that unsupervised children can not play on the trampoline.

- Always control their jump by taking off and landing in the middle of the trampoline.
- Always jump vertically and refrain from bouncing towards the springs in any direction.
- Always consult a professionally certified trampoline instructor before attempting anything beyond basic techniques.

In order to reduce the risk of accident the “SUPERVISOR” should:

- Fully understand and enforce all the safety rules and guidelines.
- Advise the trampoline user and provide knowledge in what they are doing right and wrong to ensure the safety of trampoline user.
- Be aware and advise the trampoline user of all the safety warnings.

▲ WARNING

IMPORTANT: If the Trampoline can not be supervised there should be a method for securing it and preventing anyone from using the product until supervision is available.

▲ RISK OF ACCIDENTS

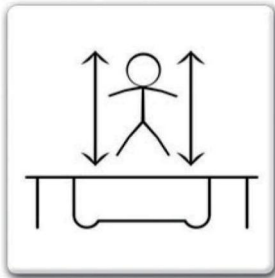

▲ WARNING

In order to reduce the risk of accident the “TRAMPOLINE USER” should:

- Always remain in control of their jumps and body position at all times.
- Not attempt to perform skills that are beyond their own level of competence.
- Read and understand the jump by taking off and landing in the middle of the trampoline.

▲ SAFETY INSTRUCTIOS GUIDE

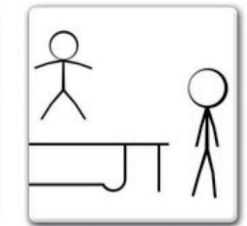
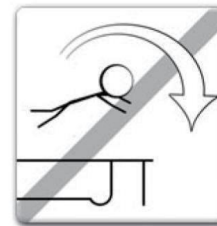

▲ WARNING

- Do not use trampoline if you have consumed alcohol or narcotic substances.
- You should climb on and off the trampoline in a controlled and careful manner. Never jump onto or off the trampoline and never use the trampoline as a means to bounce onto or into another object.
- Always learn the basic bounce and master each type of bounce before trying more difficult types of bounces .Review the basic skills section to learn how to do the basics.
- To stop your bounce, flex your knees when you land on your feet.

- Always be in control when you are bouncing on the trampoline. If at any time you feel out of control, stop bouncing immediately.
- Do not jump or bounce for prolonged periods of time or too high for a number of jumps. Keep your eyes on the mat to maintain control. If you do not, you could lose your balance.
- Never have more than 1 person on the trampoline at any one time.
- Do not attempt or allow somersaults. Landing on the head or neck can cause serious injury, paralysis, or death, even when landing in the middle of the bed.
- Do not allow more than one person on the trampoline. Use by more than one person at the same time increases the chance of injury.
- Use trampoline only with mature, knowledgeable supervision.

⚠ WARNING

ADVISORY PRECAUTIONS WHILE SUPERVISING TRAMPOLINE: Familiarise yourself with the basic jumps and safety rules. To prevent and reduce the risk of injuries, ensure all safety rules are enforced and the new users learn the basic bounces before trying more advanced techniques.

- ALL USERS need to be supervised, regardless of skill level or age.
- Never use the trampoline when it is wet, damaged, dirty or worn out. The trampoline should be inspected before use.
- Keep all objects that could interfere during use away from the trampoline at all times.
- To prevent unsupervised and unauthorized use, the trampoline should be secured at all time.

▲ ACCIDENT CLASSIFICATION & IDENTIFICATION



MOUNTING AND DISMOUNTING:

Be very careful when getting on and off the trampoline. DO NOT mount the trampoline by grabbing the frame pad, stepping onto the springs or by jumping onto the mat of the trampoline from an object (eg. A deck, roof, or ladder). This is considered highly dangerous. DO NOT dismount by jumping off the trampoline and landing on the ground. If small children are playing on the trampoline, they may need help in mounting and dismounting.



USE OF ALCOHOL OR DRUGS:

DO NOT consume any alcohol or take any drugs (this includes medication that could affect the user's co-ordination) when using this trampoline. This is considered highly dangerous since these foreign substances impair your judgments, reaction time and overall physical co-ordination.



MULTIPLE USERS:

If you have multiple users (more than one person on the trampoline at any one time), you increase the chance of being injured. Injuries can occur when you fly off the trampoline, lose control, collide with other jumper(s), or land on the springs.



STRIKING THE SPRING FRAME:

When playing on the trampoline, STAY in the centre of the trampoline mat. This will reduce the risk of being injured by landing on the spring frame. Always keep the frame pads covering the frame of the trampoline. DO NOT jump or step onto the frame pad directly since it is not intended to support the weight of a person.



LOSS OF CONTROL:

DO NOT try difficult maneuvers until you have mastered the basics. If you do not follow these guidelines, you increase the risk of someone being injured.

▲ TRAMPOLINE BASIC TECHNIQUES

BASIC SKILL1: The Basic Bounce

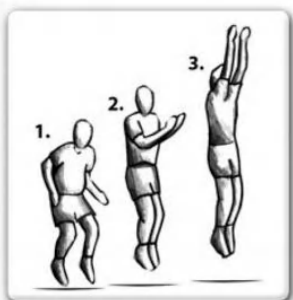

- Start from a standing position, with feet shoulder width apart head up and eyes on the trampoline bed.
- Swing arms forward and up above head in a circular motion.
- Bring legs and feet together in " mid-air " position and point toes
- Land back on the mat with feet shoulder width apart (same as start position).
- Why not try moving onto the next skill once comfortable and proficient.

BASIC SKILL 2: The Knee Drop

- Start with a low basic bounce (as detailed in BASIC SKILL 1).
- Land on knees shoulder width apart, keeping back straight and a strong body position using arms out to the side or in front to maintain balance.
- Bounce back to basic bounce position by using bounce momentum and swinging arms above head.
- Once mastered at this height try bouncing a little higher, but remember to always stay in control of your height.



BASIC SKILL 3: The Seat Drop



- Start with a low basic bounce (BASIC SKILL 1) in the normal position.
- Land with legs out straight in front of you, with hands either side of your hips and back straight in a strong body position.
- Use the bounce momentum aided with a push from hands to return to a standing position.
- Once mastered at this height try bouncing a little higher, but remember to always stay in control of your height.

⚠ WARNING

IMPORTANT: Please consult a trained trampoline instructor before attempting any more advanced skills to ensure highest possible safety levels are maintained.

▲ TRAMPOLINE ADVANCED TECHNIQUES

ADVANCED SKILL 1: The Basic Bounce

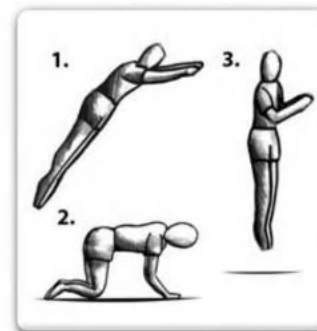

- Start with a low basic bounce (BASIC SKILL1) in the normal position
- Land on your hands and knees at the same time, ensure that back is horizontal to the bounce mat and hands & legs are shoulder width apart also.
- Use the momentum of bounce and push off hands to regain the standing position.
- Once mastered at this height try bouncing a little higher, but remember to always stay in control of your height.
- Try moving onto the next skill once comfortable and proficient.

ADVANCED SKILL 2: Hands and Knees to Front Drop

- Land on your hands and knees at the same time, ensure the back is horizontal to the bounce mat and hands & legs are shoulder width apart also.
- Maintain strong body position with back horizontal to mat and straighten legs behind and fold arms in front of face in mid-air ready to land on the mat in a lying down position.
- Ensure the landing is done with all of body touching the mat at same time.
- Push off hands and recover the standing position.
- Once mastered at this height try bouncing a little higher, but remember to always stay in control of your height .Trying moving onto the next skill once comfortable and proficient.

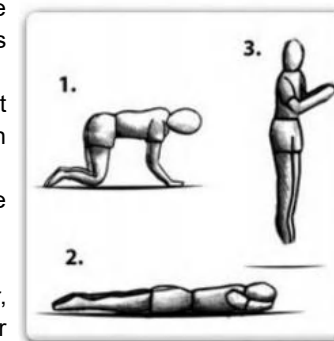



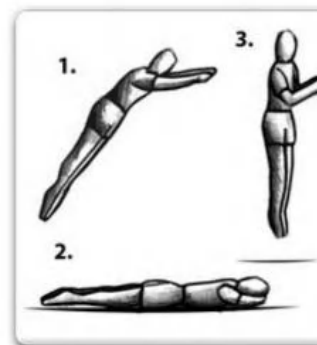



ADVANCE SKILL3: The Front Drop

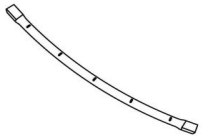
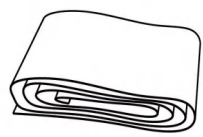
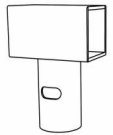

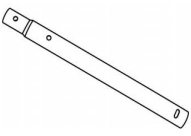
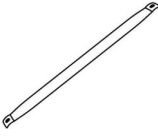
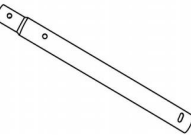
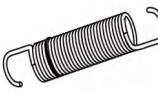
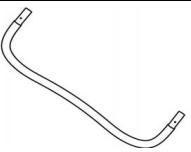
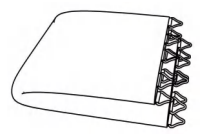
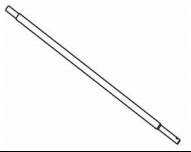

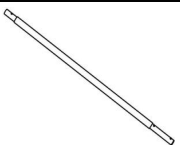

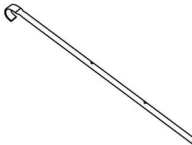

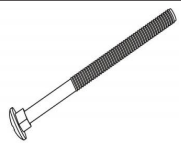

- Start with a low basic bounce (BASIC SKILL 1) in the normal position.
- Maintain strong body position with back horizontal to mat and straighten legs behind and fold arms in front of face in mid-air ready to land on the mat in a lying down position.
- Ensure the landing is done with all of body touching the mat at the same time.
- Push off hands and recover the standing position.
- Once mastered at this height try bouncing a little higher, but remember to always stay in control of your height.

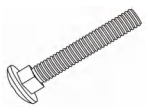
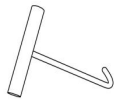
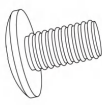
TRAMPOLINE PART LIST

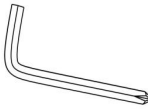
1		Top Rail	8x	9		Safety Net	1x
2		T Shaped Connector	8x	10		Rope	1x
3		Leg Extension	4x	11		Vertical Stair Parts	2x
4		Leg Extension	4x	12		Springs	64x / 72x
5		W-shaped Leg	4x	13		Jumping Mat	1x
6		Upper pole A	8x	14		Basketball Board	1x
7		Upper pole B	8x	15		Basketball Stand	1x
8		Cover Pad	1x	16		Horizontal Stair Parts	2x

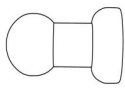
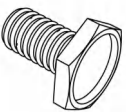
HARDWARE PARTS LIST

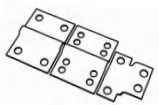
1		Screw #1	16pcs	6		Washer	16pcs
2		Screw #2	4pcs	7		Spring tool	1pc
3		Screw #3	8pcs	8		Screw tool	1pc
4		Spacer	20pcs	9		Screw tool	1pc
5		Nut	20pcs	10		Net pole cap	7pcs
Screw List Use for Basketball Board							
1		Screw #4	4pcs	3		Nut	4pcs
2		Screw #5	4pcs	4		Basketball Screw holder	1pcs

Assemble instructions

Please read the assembly instructions before beginning to assemble the product.

Please refer to the table for part descriptions and numbers. The assembly instruction use these descriptions and numbers as reference.

Please use gloves to protect your hands from pinch points during assembly. When you are ready to start, make sure that you have plenty of space and a clean dry area for assembly.

Before you start: check all the steps before assembling and read all precautions before using the trampoline.

It requires at least two adults to assemble the trampoline. Must use Protective Gloves to avoid injury during the assembly.

Make sure you have a spacious, clean and dry place, suitable for the assembly of the trampoline. It is essential that the right place for this trampoline is completely flat and level. If the ground is uneven, this could cause movement in the frame and can cause stress in the united sections of the trampoline and/or can cause serious injury.

Step 1

Insert the Leg Extension(#3) with the Leg Extension(#4) into the Base Leg(#5) and stick out completely,totally 4 legs.As shown in Fig.

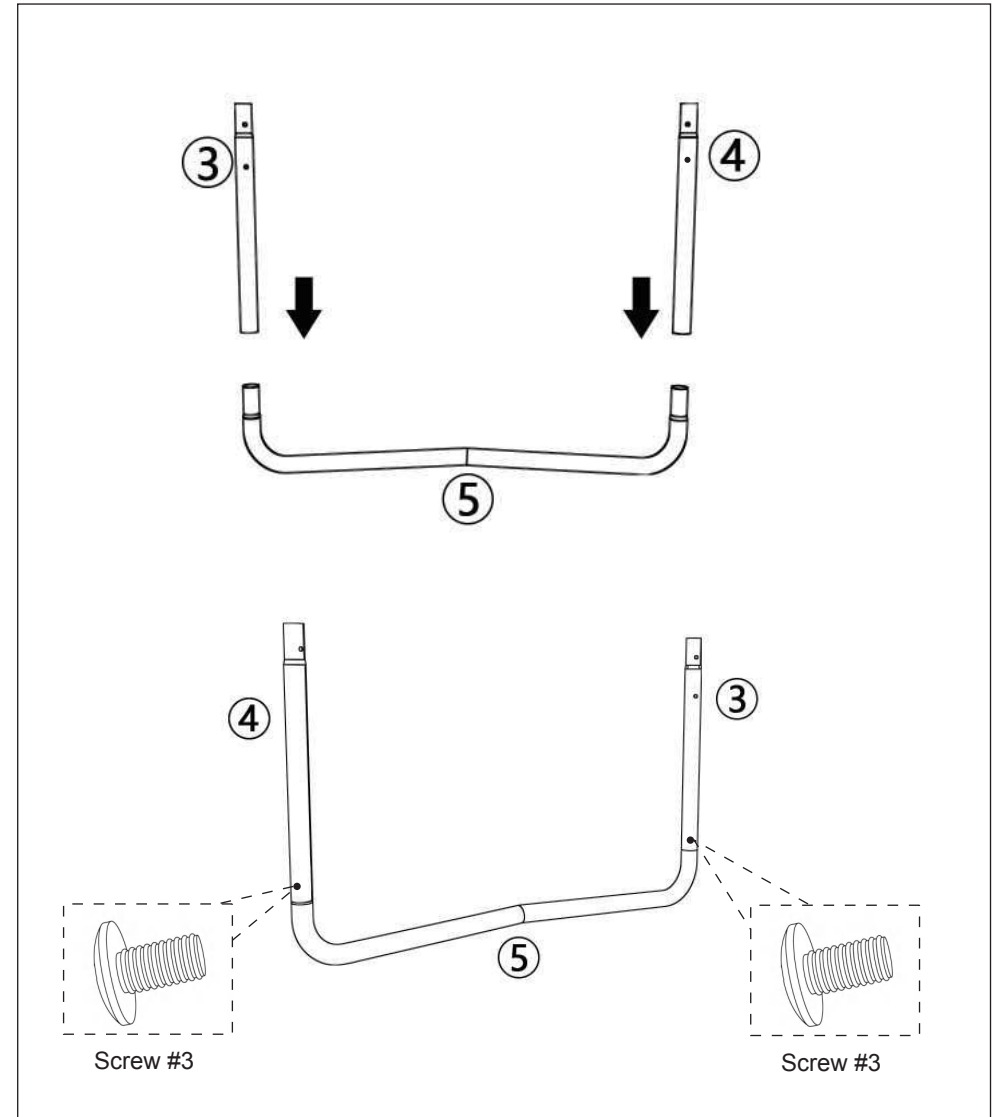

Step 2

Attach the Top Rail (#1) to the T-shaped Connector (#2) until you form the circle. As shown in Fig. (You can use great force if it is too tight)

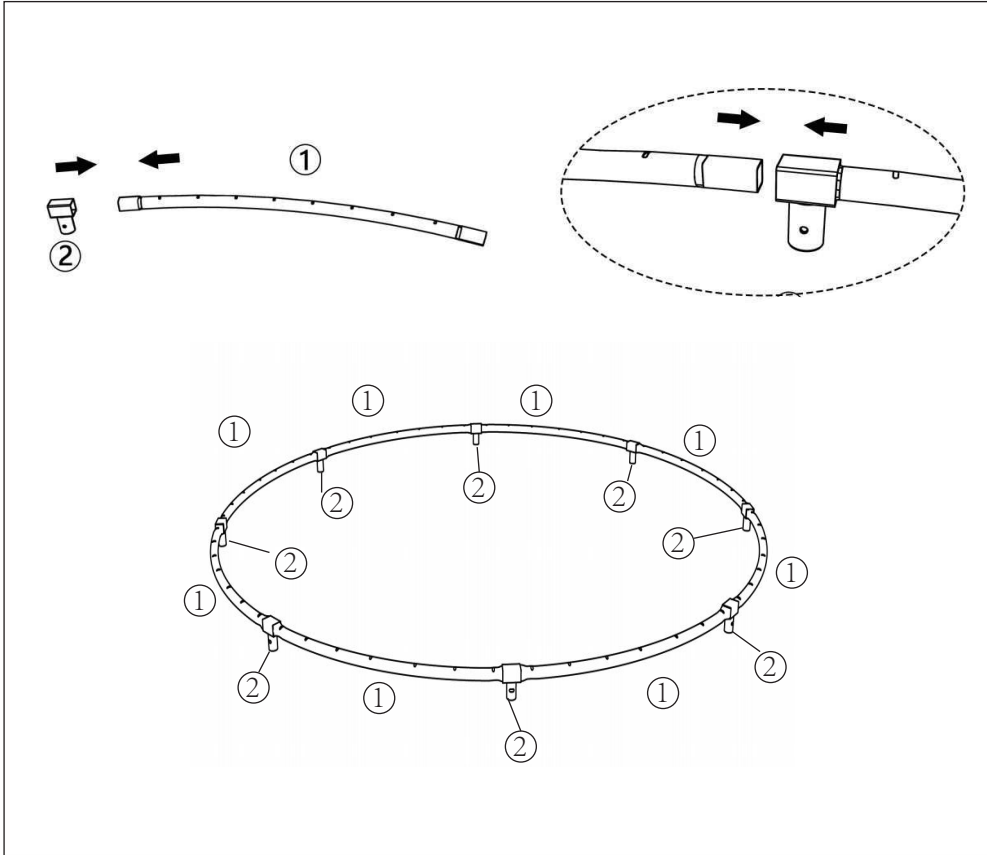

Step 3

Two people will be necessary at this point to install the trampoline. One person lifts up the circle frame, while the other lifts the W-shaped leg tubes to a standing position and inserts the T-shaped Connector (#4) into a W-shaped leg tube. Ensure the locking holes are aligned. As shown in Fig.

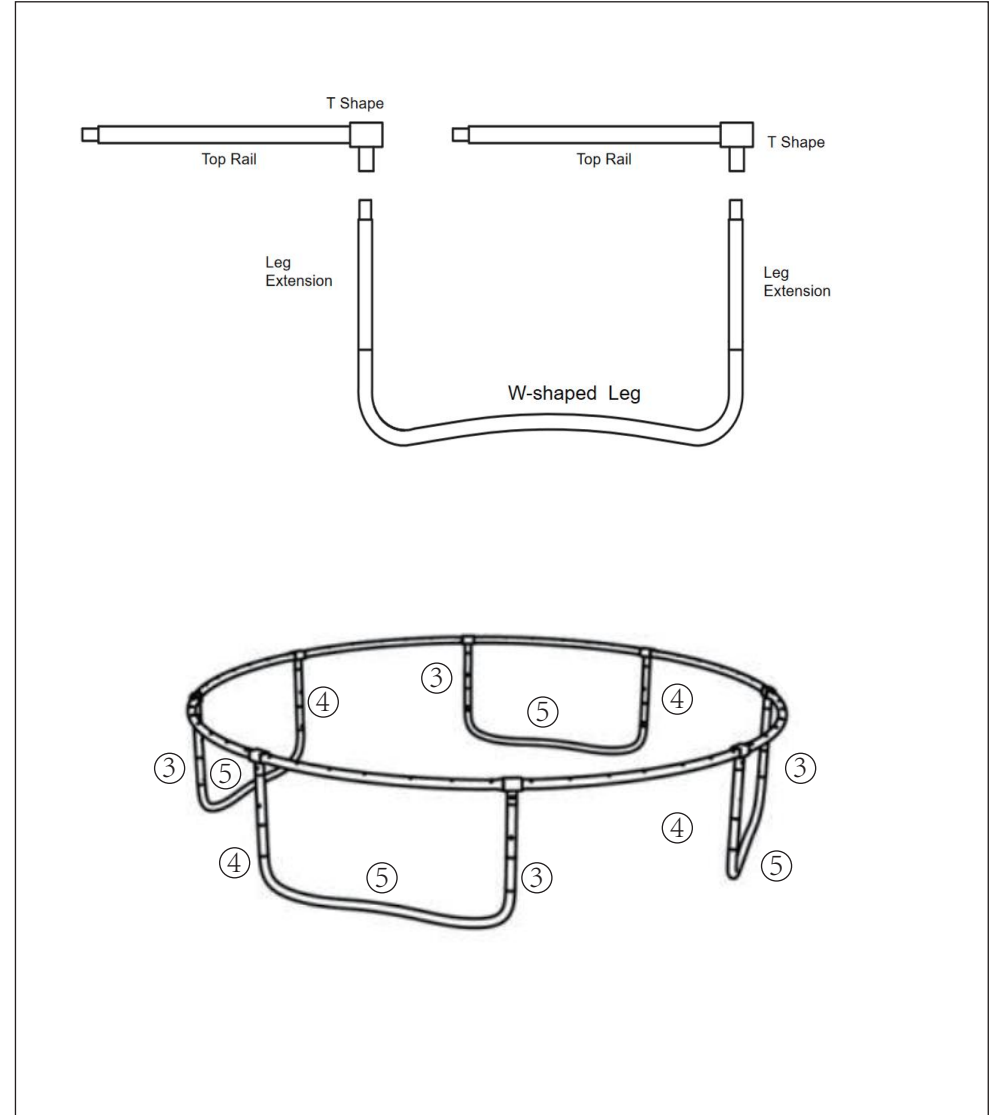

⚠️ WARNING : Attaching springs, the connector points can become pinch points since the trampoline is tightening up. With this in mind please be careful attaching springs to the trampoline mat. Please be careful.

You will need at least one person to help with this portion of assembly.

Pay attention to the operating instructions when installing the spring. Using the wrong installation method may result in unsuccessful installation.

HOW TO USE THE "SPRING TOOL"

Firstly hang one side of spring on the triangle attached to The "Trampoline Mat, and use the "spring tool" to hook the other side of spring (As shown in the top image to the right). 10FT trampoline has 64x springs, 12FT trampoline has 72x springs.

Pull the "Spring Tool" until the spring hook insert the hole on the "trampoline frame and disengage the "Spring Too" leaving the "Spring" in place. Repeat process for all springs.

⚠️ WARNING: Please be careful where your hands and other parts of the body are placed as the connector points and spring attachments can create hand or body traps.

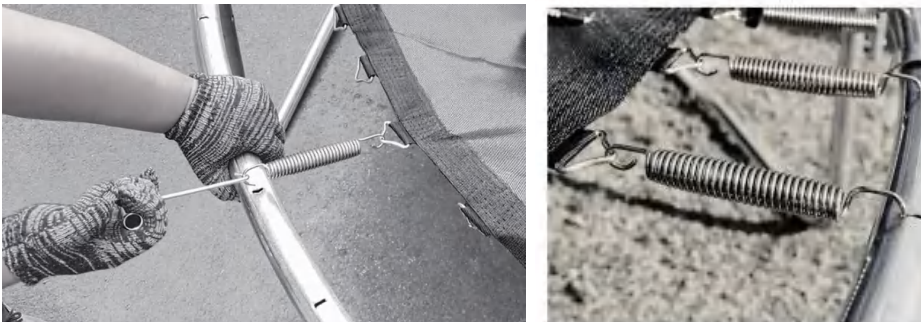

Step 4

Layout the Jumping Mat(#13) inside the circle frame.

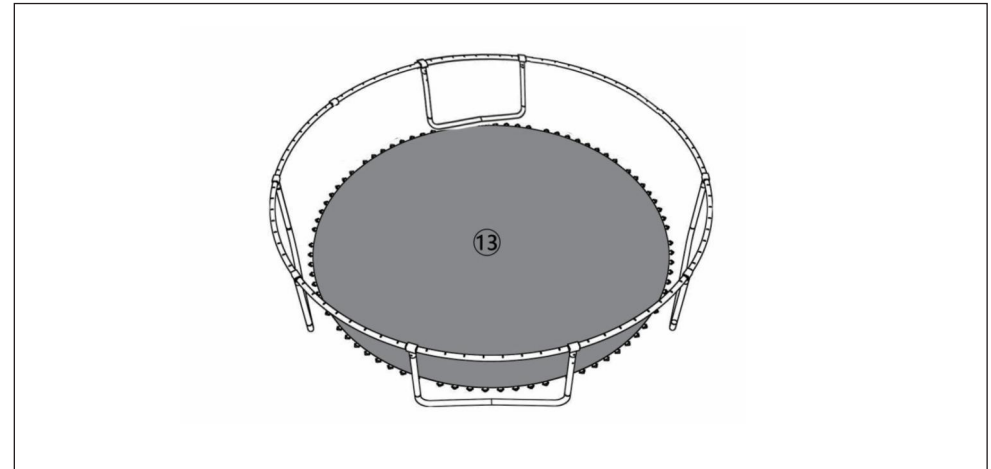

Step 5

Install the Springs(#12) in the X-shape order one by one to make sure the tension is distributed evenly for the Jumping Mat(#13) and pull it with Spring tool. As shown in Fig. (Tip: Please take care not to pinch your hands and other body parts during spring assembly.)

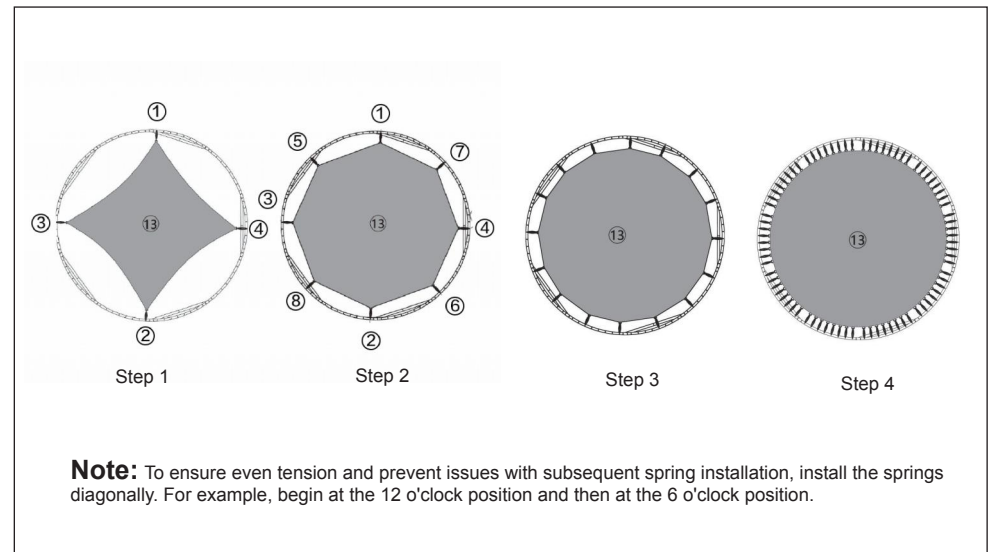



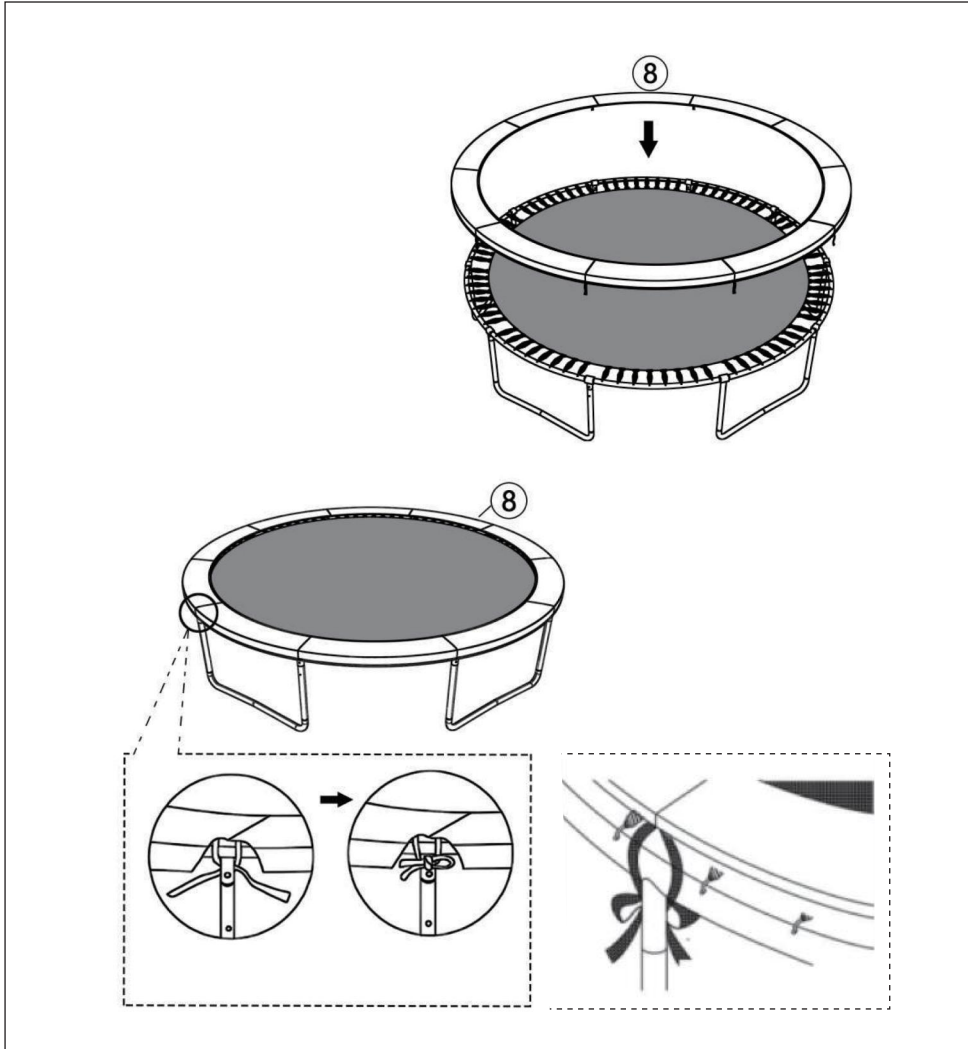

Step 6

Please lay the frame cover pad (#8) over the springs;
Tie the strap located at the under side of the frame pad to the frame. As shown in fig.

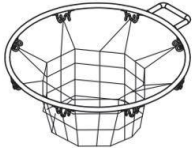
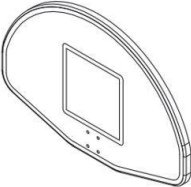
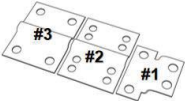
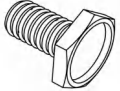

Basketboard Parts List

 <p>A 1PC</p>	 <p>B 1PC</p>	 <p>C 1PC</p>	 <p>D 4PCS</p>
 <p>E 4PCS</p>	 <p>F 4PCS</p>	 <p>G 1PCS</p>	 <p>⑦ Upper pole B</p>

- Place Screw holder (#1) of C between A and B and secure it with screw #5 E
- Place Screw holder (#2) of C on the back of the basketball board and secure it with nut F
- Use the longer Upper pole through the Screw holder (#3) of C, and tighten them with screw #4 D to the back
- Insert the installed basketball board and Upper pole into the remaining Bottom pole, and the upper half of the upper pole is secured through the net

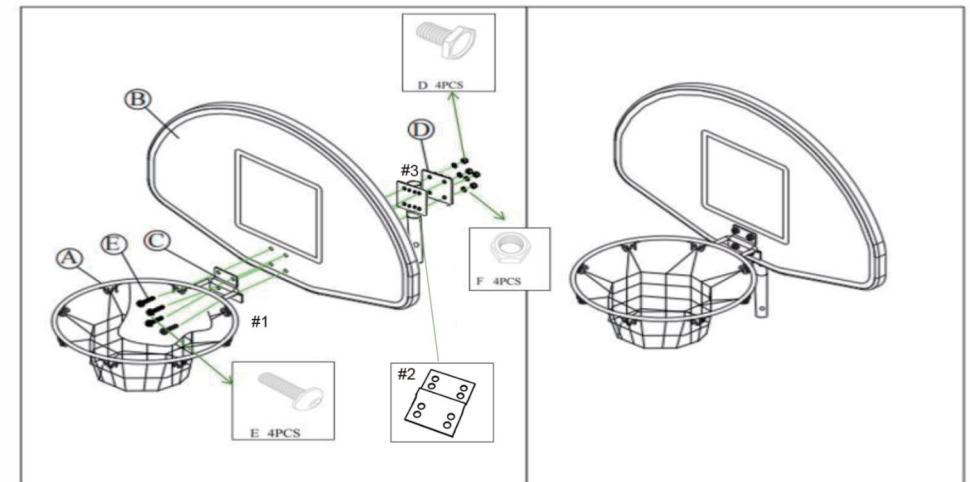

Step 7

The Upper Pole B(#6) is locked and fixed in the two holes at the upper end of Leg Extension (#3) with Screw (#1), Spacer, Nut and Washer to tighten. As shown in fig.

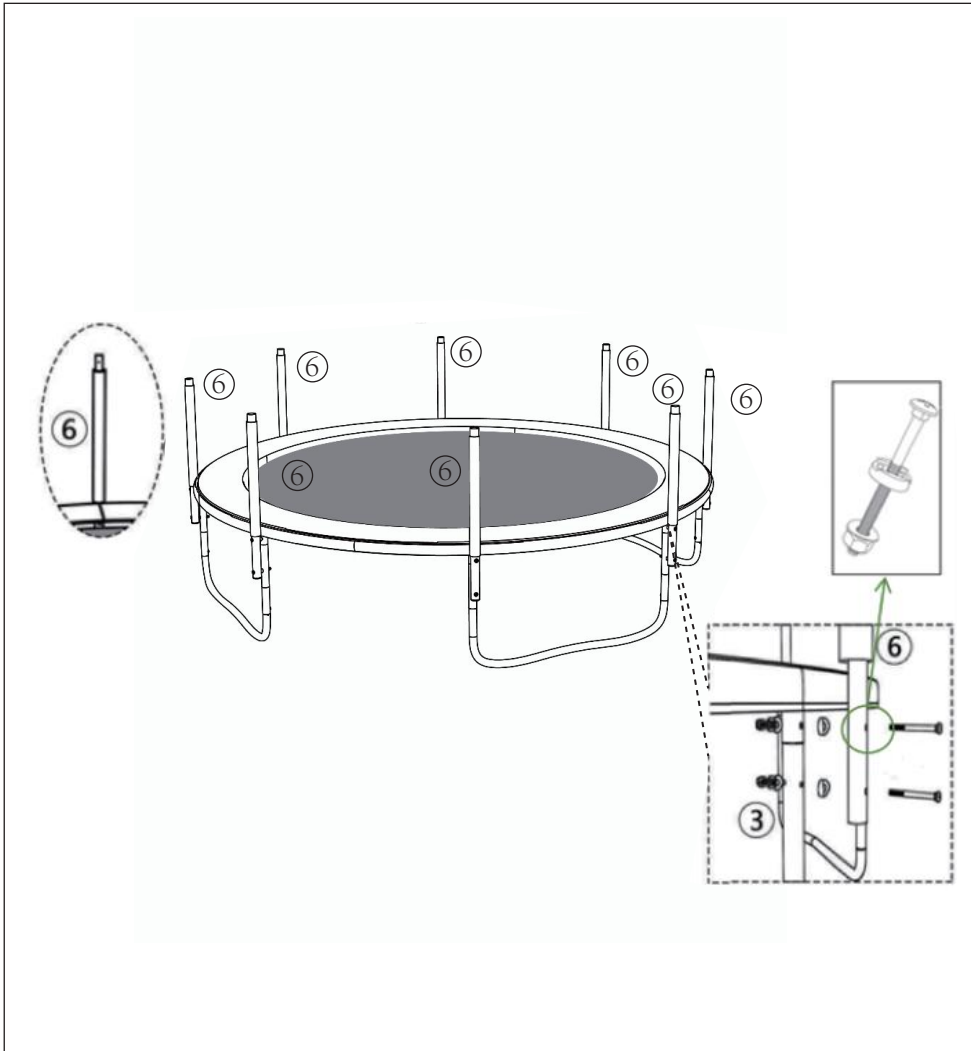

Step 8

Please insert the Upper Pole B (#7) into the Upper Pole A (#6).As shown in fig.

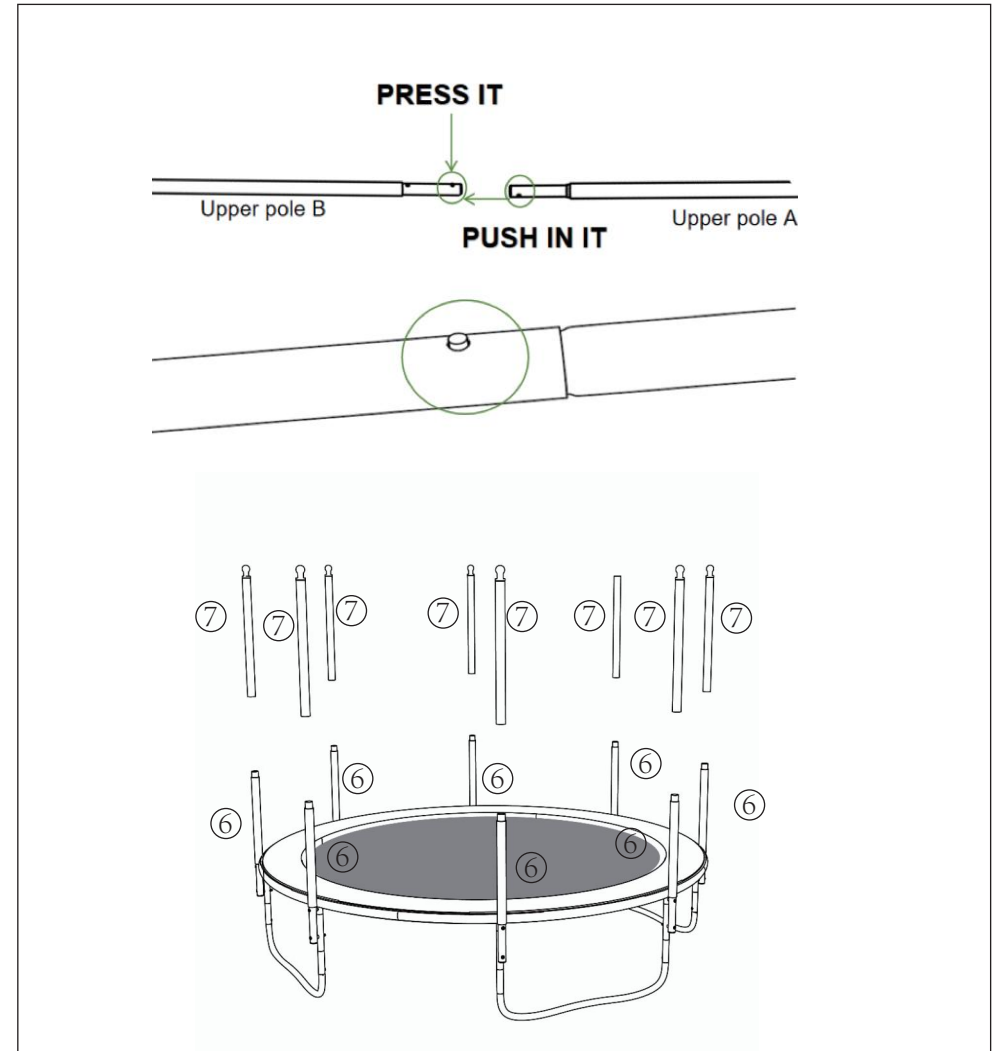

Ladder Parts List

STEP 1-Check the number of pipes required by the ladder.

Ensure there are four stair pipes ,4 pic screw #3,4 pic spacers and 4 pic nuts

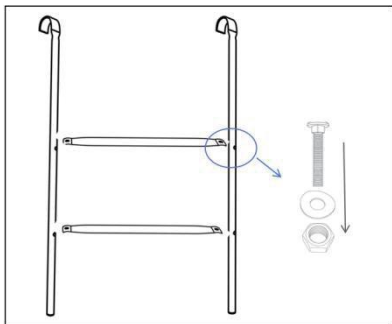
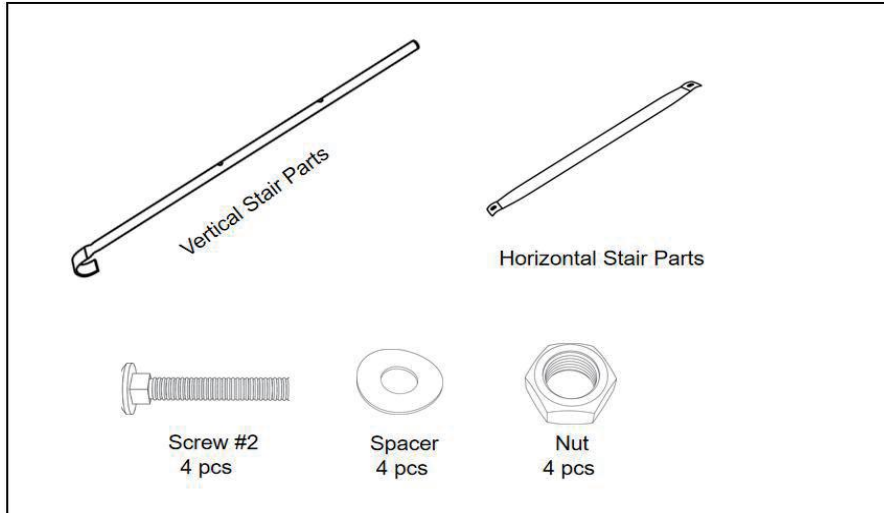

STEP 2-Position the nuts at each hole in each Step.

Ensure that nut and spacer are tightened at hole positions

STEP 3-Position the Steps over the holes in the Poles, and secure them with bolts.

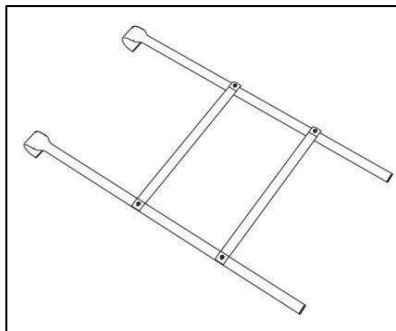

Step 9

Connect Upper Pole B (#7) into the Upper Pole A (#6), the Upper Pole A has one longer pole and seven short poles, the longer pole is reserved for install basketball board and seven short poles use to install the Net pole cap on top as shown in Fig.

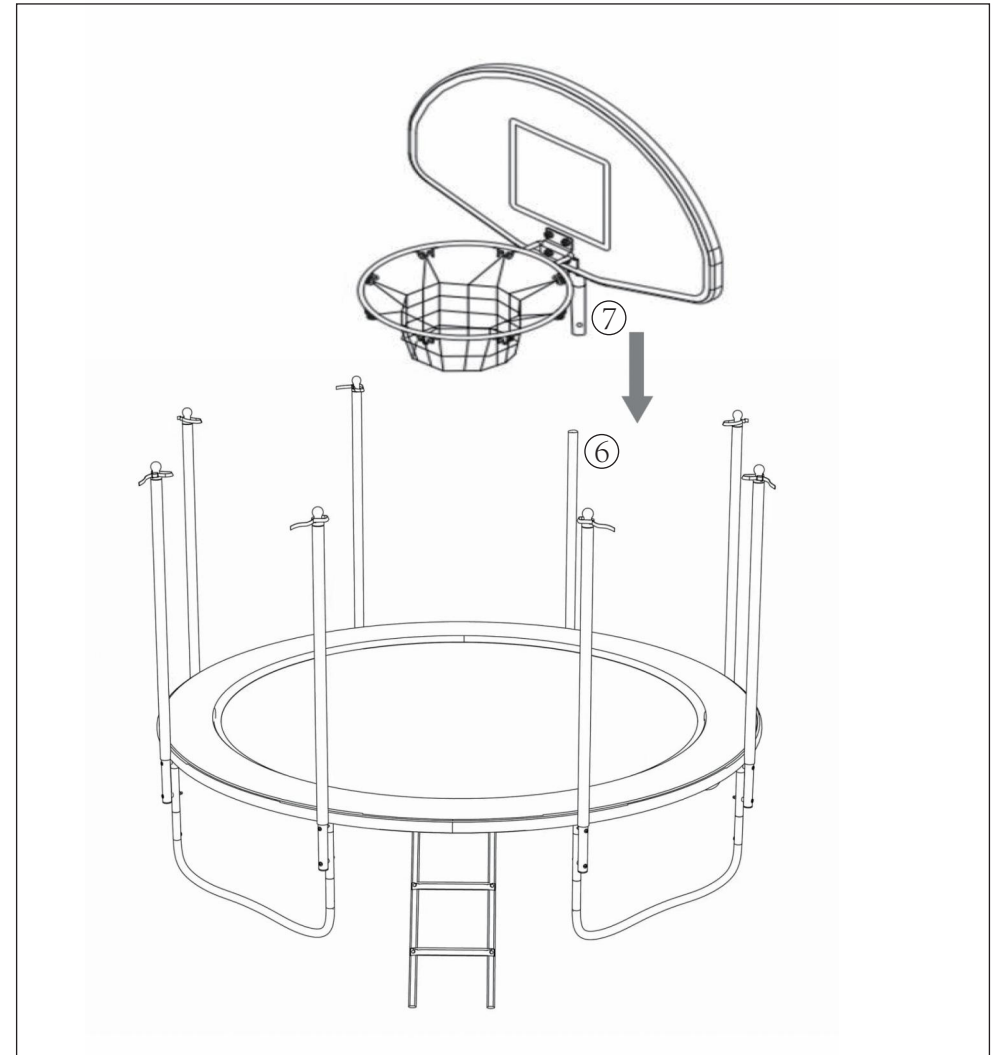

Step 10

Spread Safety Net (#9) out on the trampoline mat. Wrap the strap around the top pole cap (#7) and secure the safety net buckle. As shown in fig.



Step 11

Components Net Ropes (#10), Safety Net(#9) through the bottom hole components, and parts cross around spring, and fixed. As shown in fig.

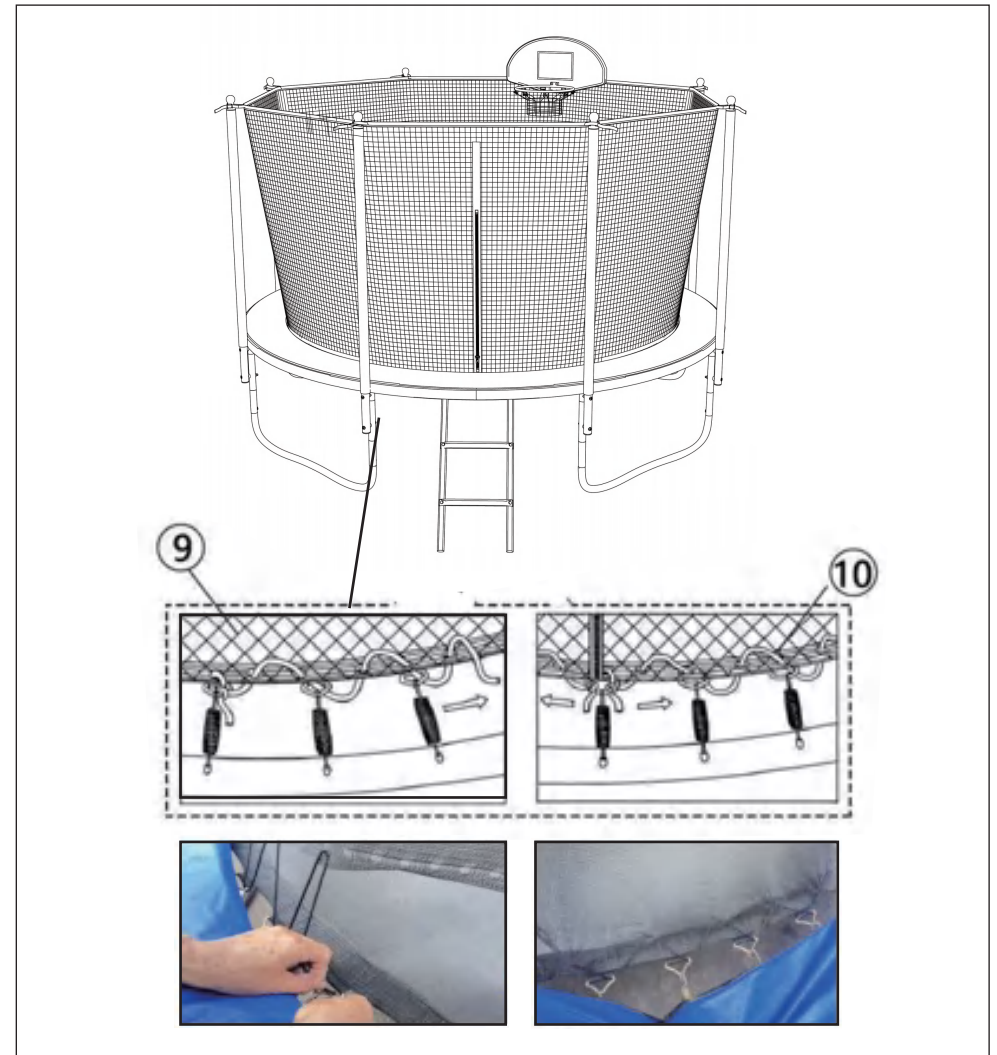

Maintenance & Care

WARNING

This trampoline was designed and manufactured with quality materials and craftsmanship. If proper care and maintenance is provided, it will provide all jumpers with years of exercise, fun, and enjoyment as well as reduce the risk of injury. Please follow the guidelines listed below:

This trampoline is designed to withhold a certain amount of weight and use. Please make sure that only one person at any one time uses the trampoline. Also, the person should weigh less than 300 pounds. Jumpers should either wear socks, gymnastics shoes, or be barefoot when using the trampoline. Please be aware that street shoes or tennis shoes should NOT be worn while using the trampoline. In order to prevent the trampoline mat from getting cut or damaged please do not allow any pets onto the mat. Also, jumpers should remove all sharp objects from their person prior to using the trampoline. Any type of sharp or pointed objects should be kept off the trampoline mat at all times.

Always inspect the trampoline before each use for worn, abused or missing parts. A number of conditions could arise that may increase your chances of getting injured.

Please be aware of:

- Punctures, holes, or tears in the trampoline mat
- Sagging trampoline mat
- Loose stitching or any kind of deterioration of the mat
- Bent or broken frame parts, such as the legs
- Broken, missing, or damaged springs
- Damaged, missing, or insecurely attached frame pad
- Protrusions of any types (especially sharp types) on the frame, springs, or mat

IF YOU FIND ANY OF THE PREVIOUS CONDITIONS, OR ANYTHING ELSE THAT YOU FEEL COULD CAUSE HARM TO ANY USER, THE TRAMPOLINE SHOULD BE DISASSEMBLED OR SECURED FROM USE UNTIL THE CONDITION(S) HAS BEEN RESOLVED.

WINDY CONDITIONS

In severe wind situations, the trampoline can be blown about. If you expect windy weather conditions, the trampoline should be moved to a sheltered area or disassembled. Another option is to tie the round, outside portion (top frame) of the trampoline to the ground using ropes and stakes. To ensure security, at least three (3) tie downs should be used.

MOVING THE TRAMPOLINE

If you need to move the trampoline, two people should be used. All connector points should be wrapped secured with weather resistant tape, such as duct tape. This will keep the frame intact during the move and prevent the connector points from dislocating and separating. When moving, lift the trampoline slightly off the ground and keep it horizontal to the ground. For any type of other move, you should disassemble the trampoline.

Recreational Trampoline

User Manual

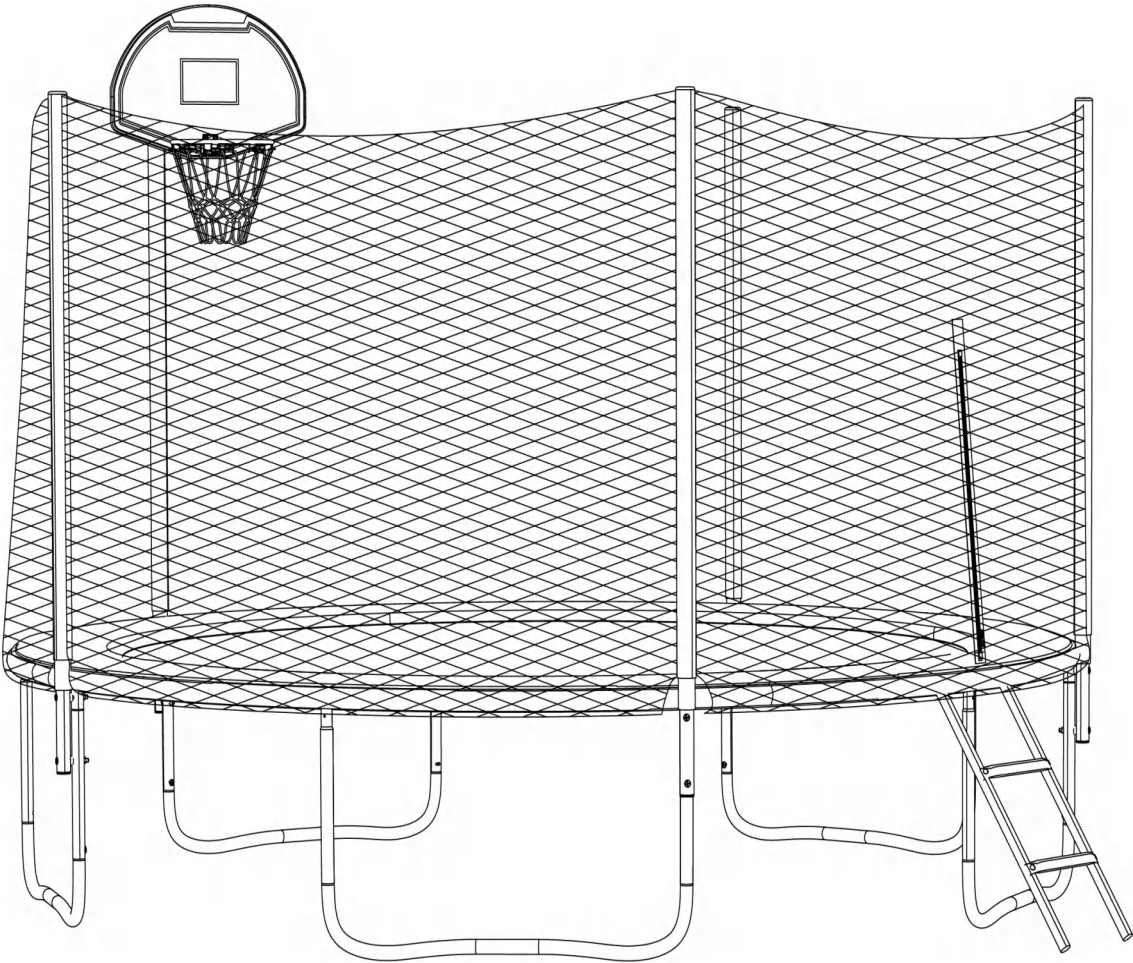

CONTENTS

General Safety Warning..... 02-04

Additional Safety Warning 05-08

Trampoline Parts List 09-10

Installation Instructions 11-18

Maintenance and Care 19-20

GENERAL SAFETY WARNING

Thank you for choosing our recreational trampolines! For the best user experience and safety, please make sure to thoroughly and carefully review this user manual before assembling and using the product, and keep it for future reference. Similar to physical sports and activities, there's always a risk of participants sustaining injuries. To safeguard your future enjoyment and prevent any potential harm, it's crucial to adhere to the relevant safety rules and tips.

Do not use the trampoline without adult or knowledgeable supervision, regardless of your skill level or age.

ALWAYS CHECK YOUR TRAMPOLINE BEFORE USE. PAYING SPECIFIC ATTENTION TO ALL THE BOLTS, JUMP MAT AND PADS POSITION. DON'T USE IF ANY PARTS ARE MISSING OR DISPLAY SIGNS OF WEAR AND TEAR.

Using Instructions

1. The Weather Conditions, Environment, and Storage Method for the Trampoline

- Avoid using the trampoline when it's wet or during windy conditions, as high winds can potentially cause it to blow away. In case of windy weather, relocate the trampoline to a sheltered area or secure it using ropes and stakes. For safety, use a minimum of three straps to fasten the round outer part (top frame) of the trampoline to the ground.
- Only bounce on the trampoline when the mat surface is dry, and ensure the wind or air movement is calm or gentle. Avoid using the trampoline in gusty or severe winds for safety.
- Avoid using the trampoline in heavy rain as it can make the jumping surface extremely slippery, posing safety risks.

2. Requirements for Trampoline Installation, Site, and Handling

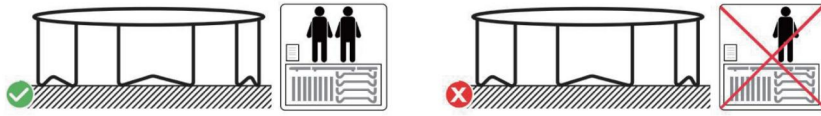

Please make sure at least 2 people install the trampoline.



Ensure the trampoline is positioned and installed on level ground. An uneven ground surface could lead to warping of the trampoline frame.



Ensure that all the bolts securing the frame joints are fully tightened before installing the springs. Do not push against the trampoline leg or frame.



Please install the springs diagonally to ensure even tension and prevent issues with subsequent spring installation.

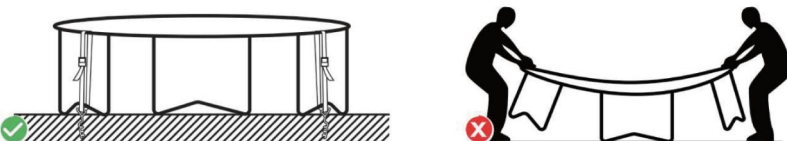

If the trampoline and enclosure need to be moved, it should be done by at least two people, keeping it horizontal, and lifting it slightly. For added safety, make sure to wrap and secure all connection points with weather-resistant tape, such as duct tape. This will help keep the frame intact during the move and prevent the connection points from shifting or separating.

3. Dress Requirements for Trampoline Use

- Select clothing without drawstrings, hooks, or loops that could potentially cause entanglement or pose suffocation risks while using the trampoline.
- When using the trampoline, it's important to wear appropriate clothing, preferably sportswear and socks. NEVER WEAR SHOES ON THE MAT.
- It's advisable to remove glasses, watches, bracelets, necklaces, and any other items that could easily fall off.

4. Physical Examination

- Always consult a doctor/physician prior to engaging in any physical activity.
- Do not use the trampoline while under the influence of alcohol or drugs.

5. Other Instructions for Use

- Somersaults and flips are strictly prohibited, as landing on the head or neck may result in severe injury, paralysis, or even fatality, even if landing in the center of the mat.
- The trampoline should be assembled on grass or BSI-approved safety matting.
- Trampolines over 20in (51cm) tall are not recommended for children under 6 years old.
- Stop exercising immediately if you feel unwell or experience pain in your joints and muscles. If you feel dizzy, a sign of fatigue, stop bouncing and have a good rest.
- If a trampoline ladder is utilized, the supervisor should remove it from the trampoline when not in use to prevent unsupervised access by children under 6 years old.
- Do not use the trampoline without adult or knowledgeable supervision, regardless of your skill level or age.
- Before each use, carefully inspect the trampoline for bent tubes, a torn mat, loose or broken springs, and check the overall stability.
- Do not use the trampoline as a springboard. Do not get off by jumping off the trampoline and landing on the ground, even if it's a grassland.
- Avoid reckless or prolonged bouncing on the trampoline, as it heightens the risk of injury.
- Ensure that all jumpers adhere to the weight limit when playing on the trampoline. Always jump in the middle of the mat and practice bouncing techniques safely under adult supervision and guidance.
- Never put any items on the trampoline while someone is playing, and ensure there are no activities taking place beneath it. Always securely close the safety net before anyone starts jumping.
- Ensure that any potential obstructions are kept away from the trampoline to prevent interference with the jumper.
- Do not use the trampoline when it is wet, damaged, dirty, or worn out, and refrain from using it as a device for bouncing onto or into another object.
- Keep the safety enclosure tightly fastened to the trampoline in accordance with the manufacturer's instructions. Do not attach anything to the safety enclosure that is not a manufacturer-approved accessory or part.
- Learn fundamental bounces and body positions thoroughly.
- Avoid bouncing too high. Maintain control.
- Ensure that the trampoline is properly secured when not in use to prevent unsupervised and unauthorized usage.
- For skill training information, contact a trainer certification organization.



ADDITIONAL SAFETY WARNING



Somersaults are strictly prohibited, as landing on the head or neck can result in severe injury, paralysis, or even fatality, even if landing in the center of the mat.



Do not allow more than one person on the trampoline or inside the trampoline enclosure. Used by more than one person at the same time may result in serious injury.



Do not jump with sharp objects in your hands or pockets.



Do not attempt to jump over the enclosure net hit or.



Do not intentionally rebound off the enclosure net or hang from, kick, cut, or climb on it.



Do not jump from high ledges into the trampoline and avoid dangerous tricks.



Do not use the trampoline if there are obstructions underneath the jumping mat.



Do not exceed weight limit.



Do not dunk or hold onto the basketball rim.



Do not place any sharp objects on the trampoline.

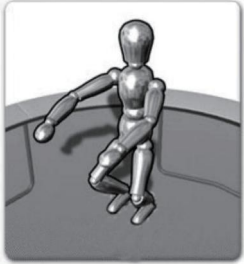

BEFORE YOU TRY TO JUMP TOO HIGH: It's important to learn the technique for stopping. It's recommended to land with bent knees, allowing them to absorb the spring of the mat. This position is shown in the image on the left. Additionally, extending the arms can enhance balance.

This technique is employed when the trampoline user intends to stop bouncing, whether due to fatigue, loss of control, or any other reason.



FOREIGN OBJECTS: Do not use the trampoline if there are pets, children, or any objects beneath it. Refrain from holding any foreign objects in your hand or placing items on the trampoline while in use. Additionally, avoid positioning the trampoline under overhanging objects such as tree branches or wires, etc. As these conditions heighten the risk of potential injuries.



POOR MAINTENANCE: A trampoline in poor condition will raise the risk of injuries. Before each use, please inspect the trampoline for bent steel tubes, a torn mat, loose or broken springs, and ensure overall stability.



WEATHER CONDITIONS: Please be aware of weather conditions when using the trampoline. A wet mat may cause slips and injuries, while strong winds can lead to loss of control.



RESTRICTING ACCESS: When the trampoline is not in use, securely store the access ladder to prevent unsupervised children from playing on the trampoline.

▲ RISK OF ACCIDENTS

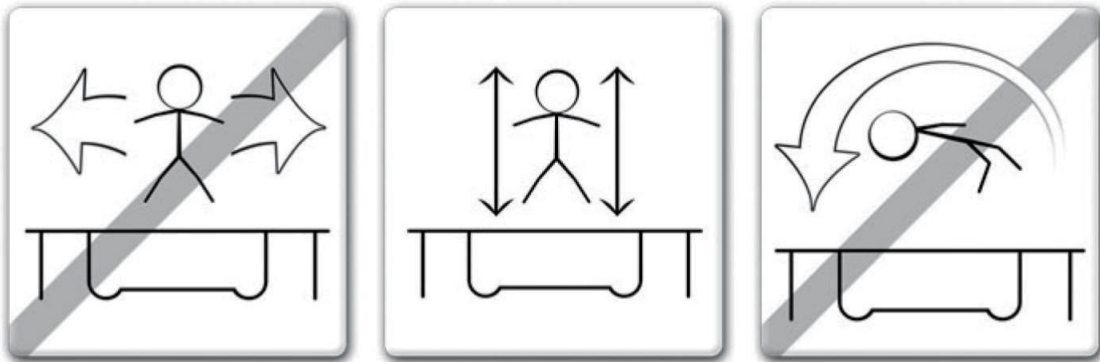

In order to reduce the risk of accidents, the Trampoline User should:

- Maintain control of their jumps and body position at all times.
- Not attempt skills beyond their own competence level.
- Understand the jump by taking off and landing in the middle of the trampoline.
- Always control their jump by taking off and landing in the middle of the trampoline.
- Always jump vertically and refrain from bouncing towards the springs in any direction.
- Always consult a professionally certified trampoline instructor before attempting anything beyond basic techniques.

In order to reduce the risk of accidents, the Supervisor should:

- Fully understand and enforce all the safety rules and guidelines.
- Guide the trampoline user, offering feedback on their actions to ensure their safety and well-being.
- Be aware and advise the trampoline user of all safety warnings.





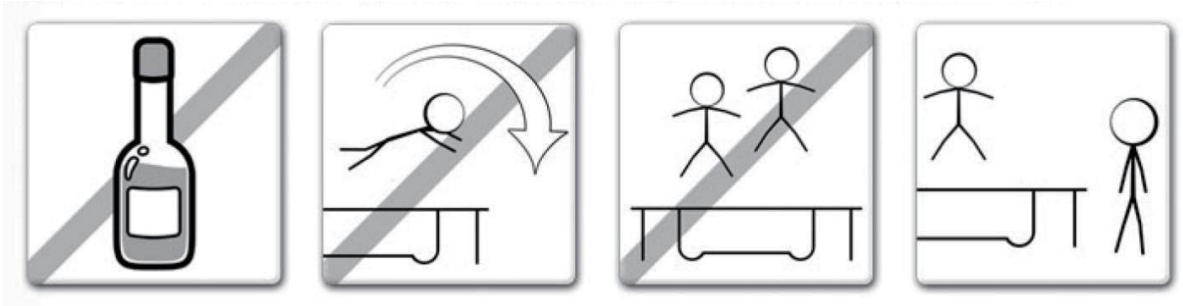





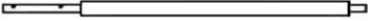

Note: If the trampoline cannot be supervised, there should be a method to secure it, preventing anyone from using the product until supervision is available.

▲ SAFETY INSTRUCTIONS GUIDE





- Avoid using the trampoline after consuming alcohol or narcotic substances.
- Climb on and off the trampoline in a controlled manner. Avoid jumping onto or off it and refrain from using it to bounce onto or into other objects.
- Master the basic bounce before attempting more difficult types.
- To stop your bounce, flex your knees upon landing.
- Maintain control at all times while bouncing. Stop bouncing immediately if you feel out of control.
- Avoid prolonged or excessively high jumping sessions. Keep focus on the mat to retain control and prevent imbalance.
- Do not allow more than one person on the trampoline to minimize the risk of injuries.

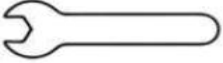
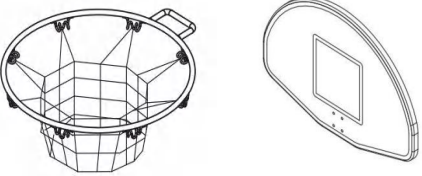

Trampoline Parts List

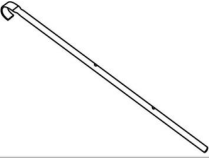
1		Frame Tube	10
2		T-shaped Connector	10
3		Leg Extension Tube (two holes)	5
4		Leg Extension	5
5		U-shaped Leg	5
6		Lower Net Pole	5
7		Upper Net Pole	5
8		Frame Cover	1
9		Safety Enclosure Net	1
10		Screw Pack	5
11		Screw Pack	5
12		Spring	80
13		Jumping Mat	1

14		Spring Loading Tool	1
15		Wrench	1
16		Basketball Backboard	1

17		Vertical Stair Part	2
18		Horizontal Stair Part	3
19	 M6*35	Screw Pack	6

Scerw List Use for Basketball Board

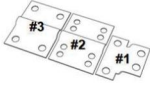
1		Hexagon Head Bolt	4
2		Flat Round Head Inner Hexagon Screw	4
3		Nut	4
4		Mounting Bracket	1

Installation Instructions

Ensure you have a spacious, clean, and dry area suitable for assembling the trampoline. It's crucial that the installation site is entirely flat and level. Please ensure that at least two people are involved in installing the trampoline and use protective gloves to avoid injury during assembly.

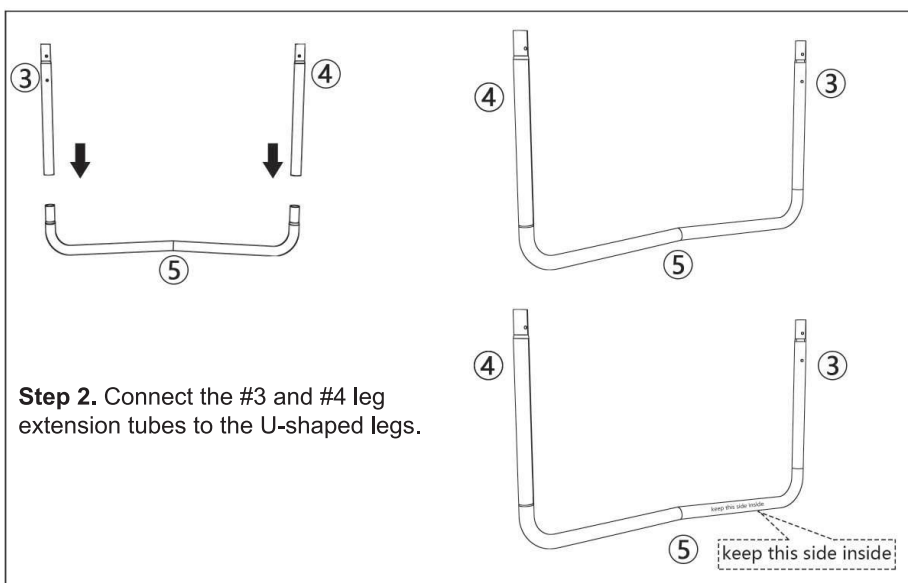
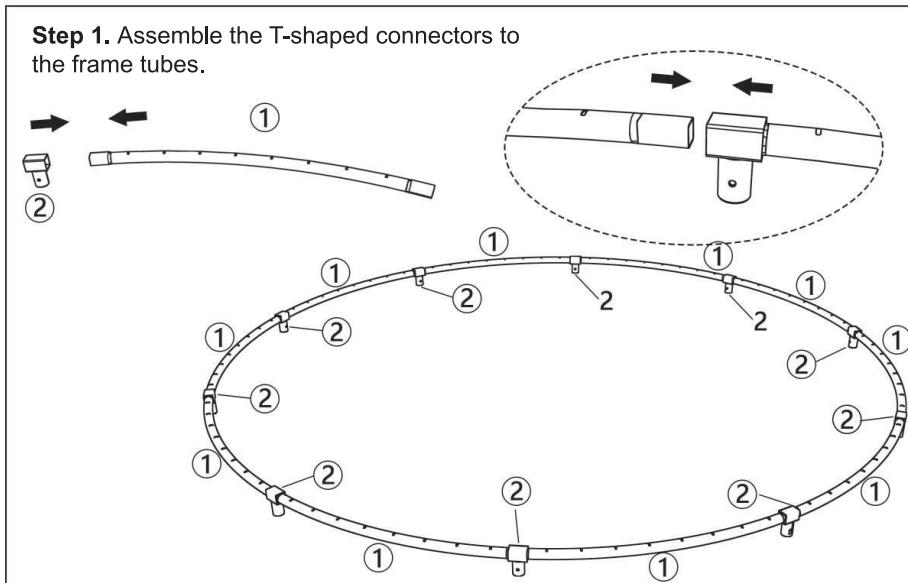

Step 3. Two people are needed at this point to install the trampoline.

One lifts the frame, while the other insert the assembled

U-shaped legs into T-shaped connectors.

Ensure precise alignment of the

locking holes.

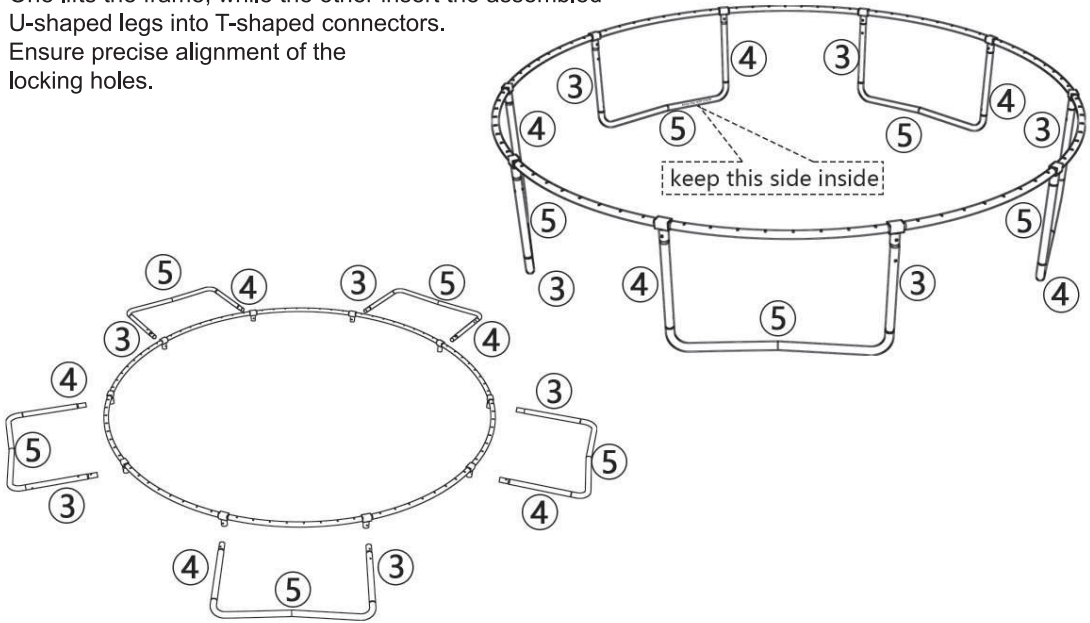

Step 4. Lay the jumping mat flat inside the frame.

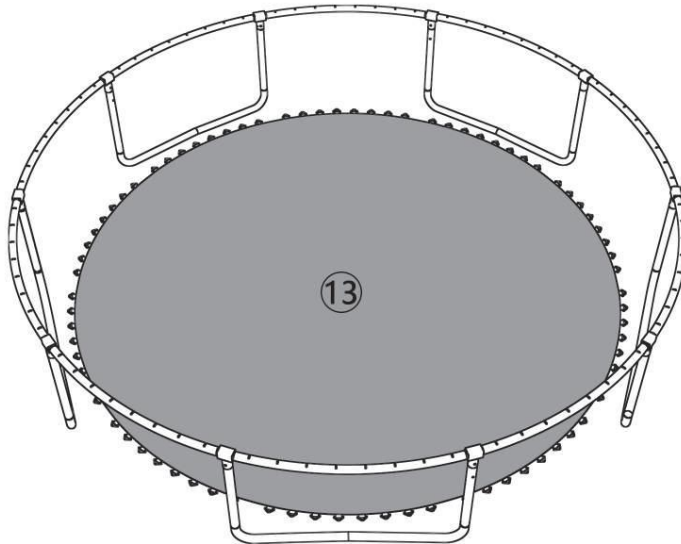

Step 5. Attach the jumping mat to the frame using springs. Ensure the initial attachment to the two sides of the T-shaped connectors on the frame, then install the springs diagonally to ensure even tension and prevent issues with subsequent springs installation.

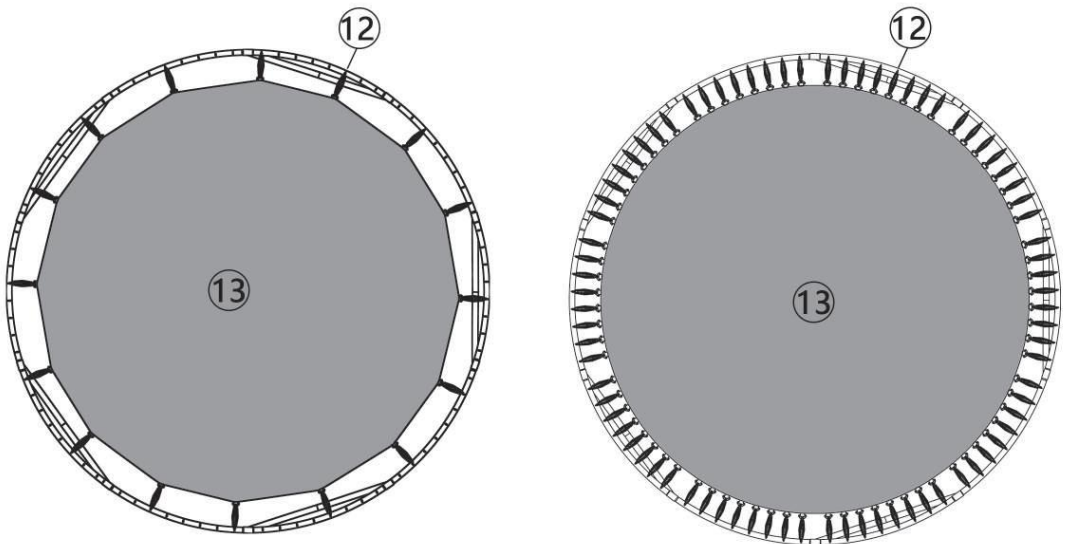
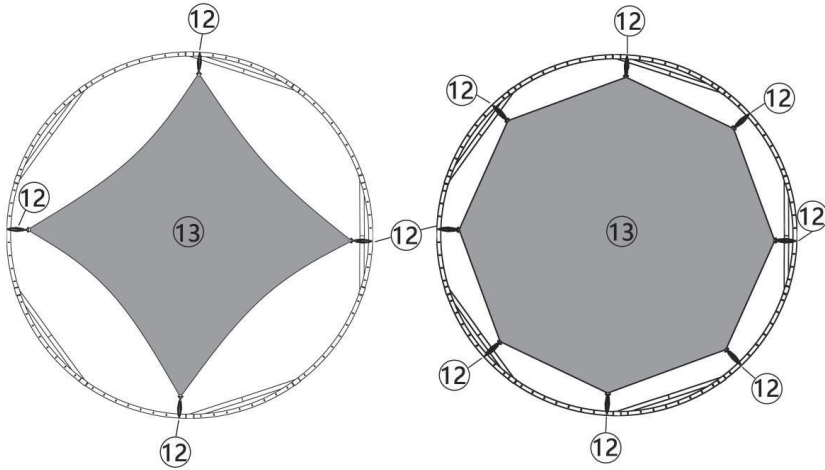

Step 6. Lay the frame cover over the springs, and tie the straps to the frame.

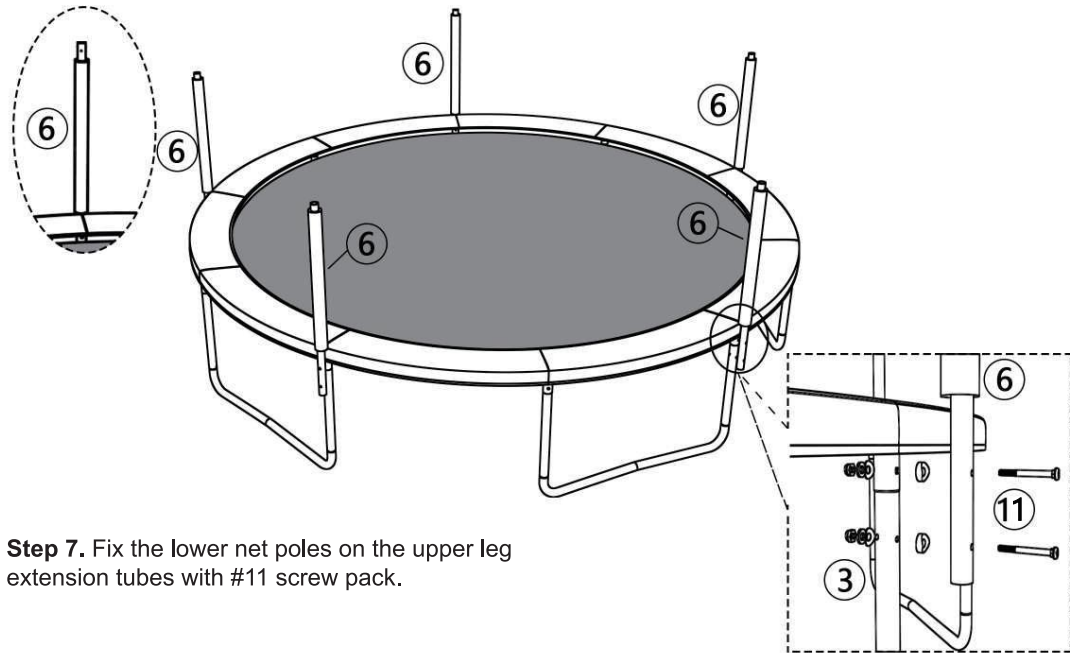
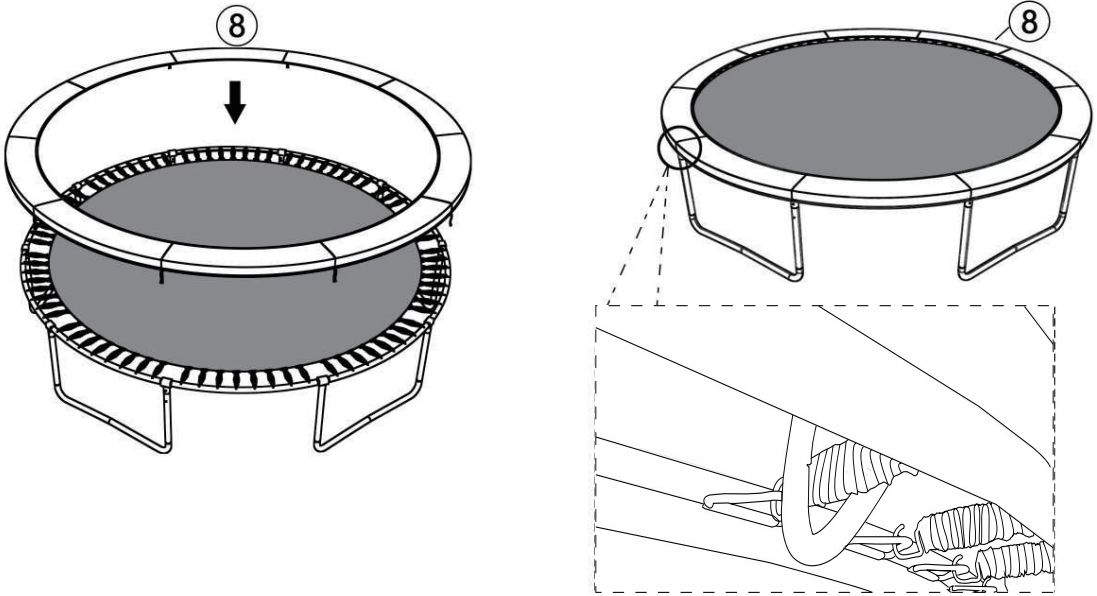

Step 7. Fix the lower net poles on the upper leg extension tubes with #11 screw pack.

Step 8. Insert the upper net poles into the lower net poles.

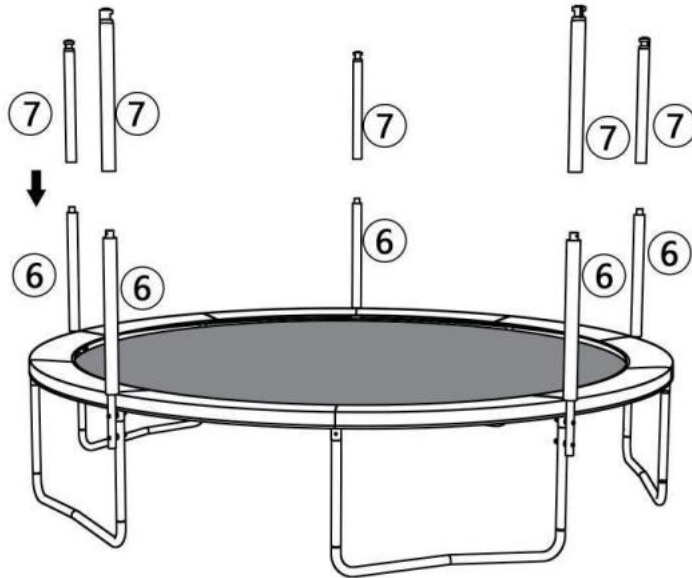

Step 9. Slide the sleeves of the safety enclosure net into the assembled net poles, and snap the buckle to the V-ring of the jumping mat.

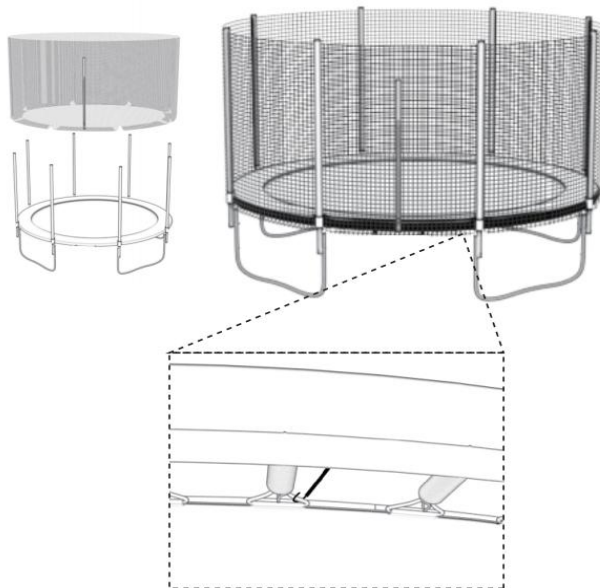

Step 10. Thread the net rope through the bottom holes of the safety net and the V-rings of the springs, and then fix.

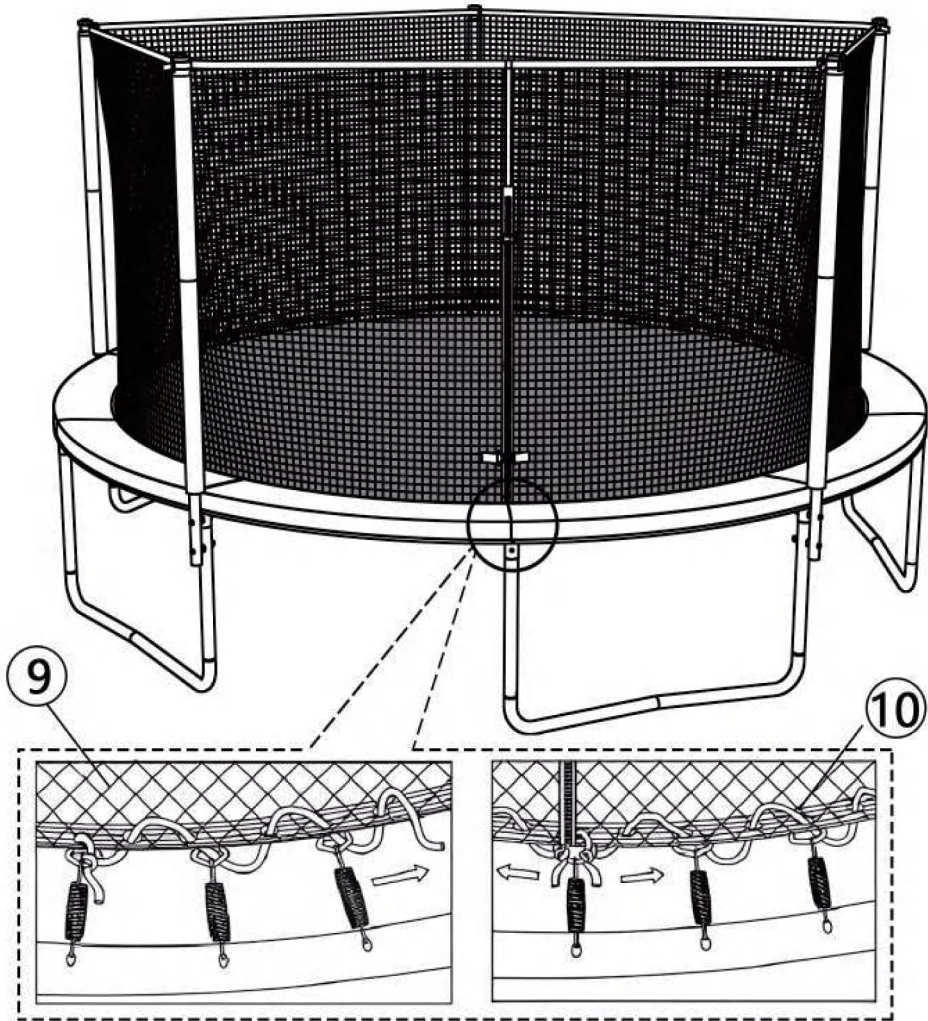

Step 10. Assemble the basketball backboard and rim using mounting bracket and screws; install the longer net pole to the back of the backboard, then, insert it into the net pole.

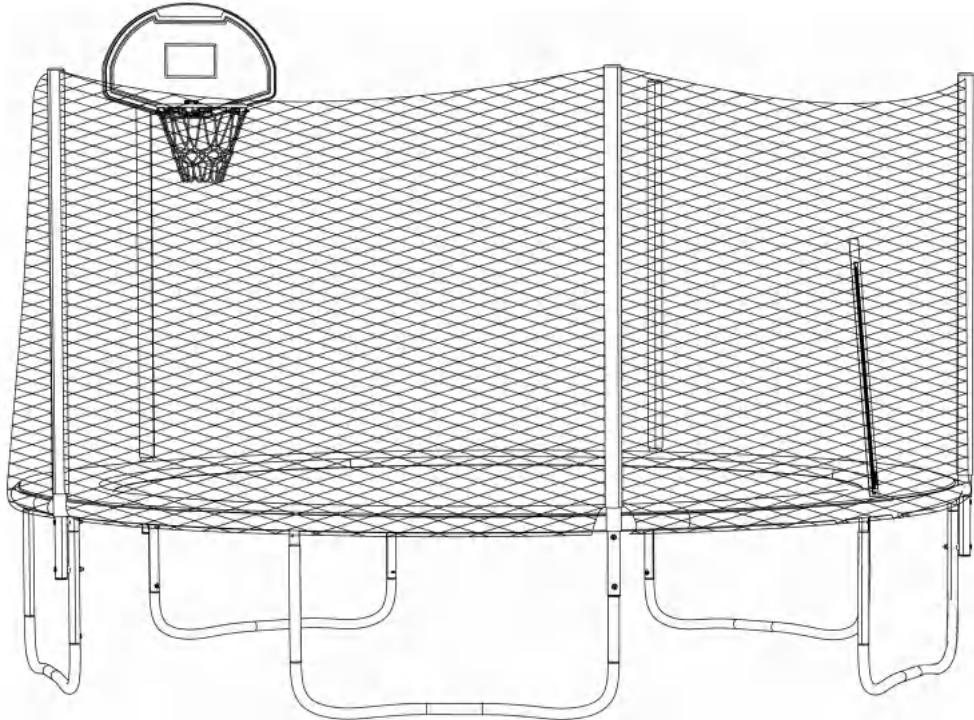
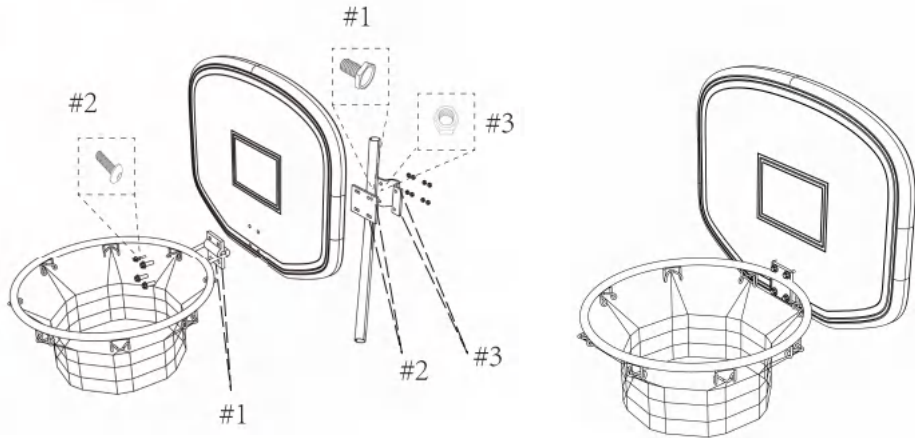

Step 11. Assemble the ladder using #19 screw pack, and then attach the ladder to the frame tube below the safety enclosure net exit. Congratulations! Assembly is now complete!

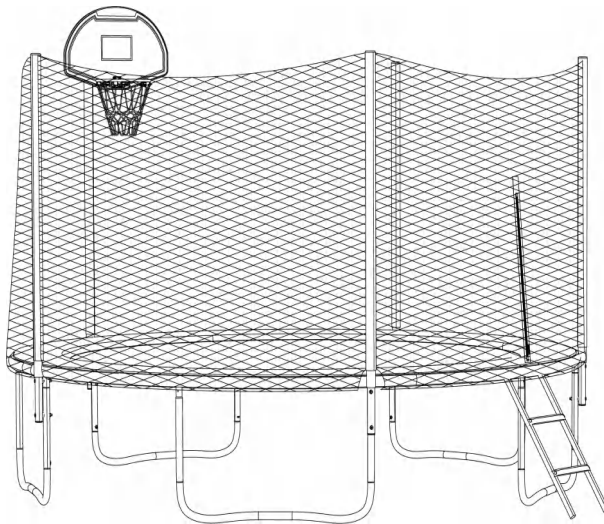
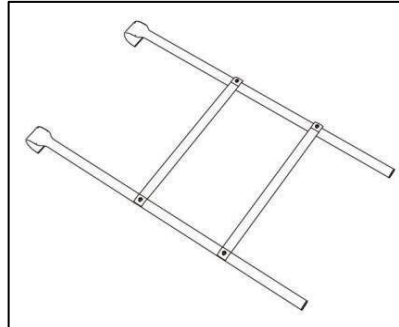
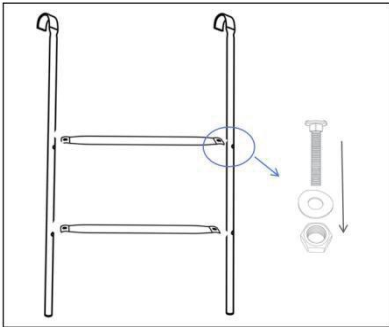

Maintenance and Care

Performing regular maintenance and providing proper care will help prolong the lifespan of the trampoline and decrease the risk of potential injuries.

Trampoline Inspection

Before each use, it is crucial to inspect the trampoline and replace any components that are worn, defective, or missing. The following conditions may present potential hazards:

- Missing, improperly positioned, or insecurely attached frame padding.
- Puncture, frays, tears, or holes worn in the jumping mat or frame padding.
- Deterioration in the stitching or fabric of the mat or frame padding.
- Sharp protrusions on the frame or suspension system.
- Ruptured springs.
- A bent or broken frame.
- A sagging mat.

Jumping Mat Inspection

The only thing between the jumper and the ground is the mat. If a deteriorated mat is not inspected properly, further jumping may cause the mat to detach from the straps over a large area, leading to the risk of the jumper landing on the ground and sustaining serious injuries. Therefore, if any deterioration is found, all bouncing must stop immediately, and the trampoline should either be disassembled or made inaccessible to prevent use until the issue is resolved. The following conditions may represent potential hazards:

- Broken stitching along the mat's edge.
- Rotten or frayed fabric around the V-ring straps.

Safety Enclosure Net Inspection

Before each use, inspect the trampoline enclosure net and replace any worn, damaged, or missing parts. The following conditions may represent potential hazards:

- Missing, improperly positioned, or loosely attached enclosure net or frame padding and pole caps.
- Punctures, frays, tears, or holes in the enclosure net or frame padding.
- Sharp protrusions on the frame or suspension system.
- Deterioration in the stitching or fabric of the enclosure net or frame padding.
- A bent or broken frame.
- A sagging enclosure net.

Extreme Cold Weather Protection

Our trampolines are designed for year-round outdoor use. However, in climates with cold weather where snow and ice are common, we recommend removing and storing the trampoline mat, springs, frame pad, and net in a dry area out of the sun. To disassemble, simply follow the installation instructions in reverse order.

Care

Regularly inspect, clean, and wash your trampoline mat with a garden hose every two weeks.

- Before using the trampoline, ensure there are no sharp objects, leaves, debris, mildew, or bird droppings on it.
- Jumpers should either wear socks or be barefoot when using the trampoline.
- Keep your trampoline away from potential fire sources, such as a grill.
- Do not allow pets or animals to access the jumping area.
- Store the trampoline in a dry area with good ventilation when it's not in use.
- Using the rain cover to protect the trampoline from UV damage, or other potential issues.
- Using the rain cover can help keep your trampoline clean and prevent leaves or bird droppings from accumulating on the mat when you move the trampoline to a sheltered area (note that at least two adults are required when removing it).