



# TRUNDLE BED

## ASSEMBLY INSTRUCTIONS



Before assembling your trundle bed, please read through these instructions carefully. Familiarize yourself with the different parts.

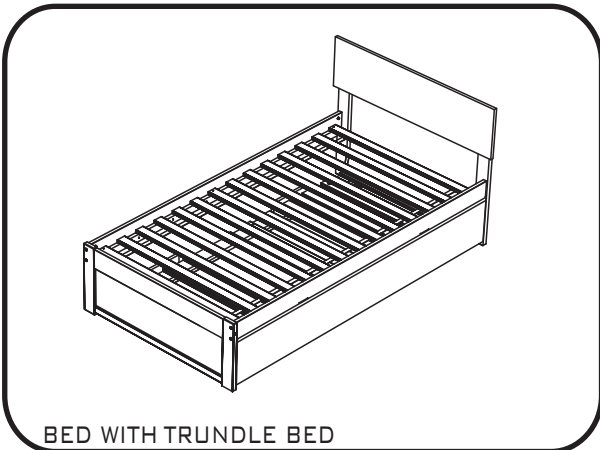
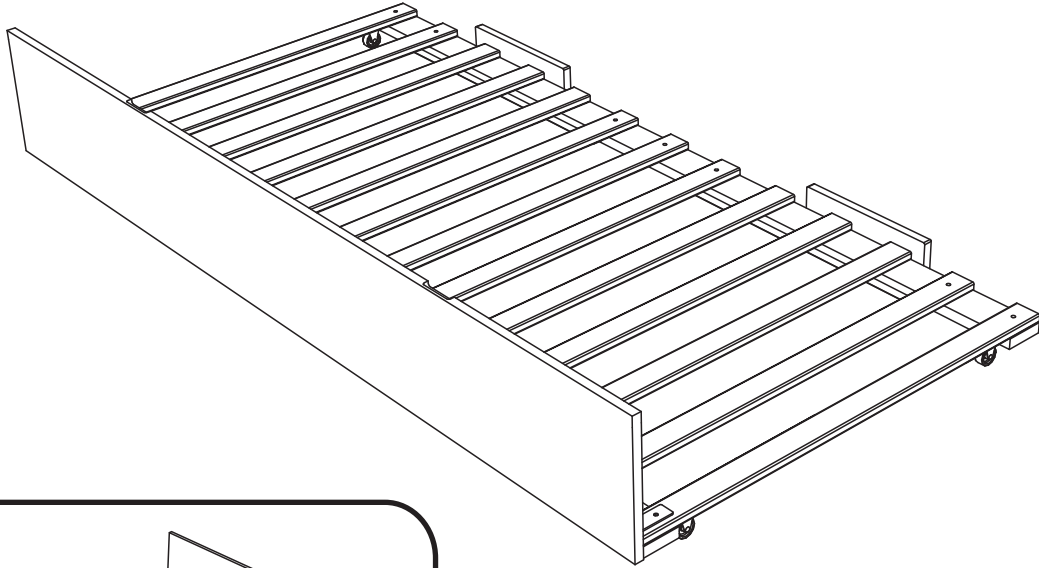
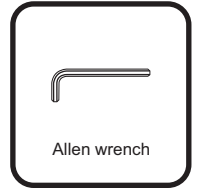

## HARDWARE

NOTE: WE INCLUDE SPARE HARDWARE IN CASE THE ALLEN WRENCH, JCB OR BARREL NUT ARE DAMAGED DURING ASSEMBLY.

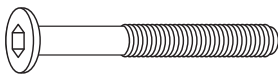
- A**  JCB M6 X 2 3/8" ( 60mm ) - 4 pcs  
Spare - 1 pc

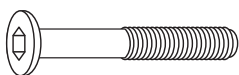
- B**  JCB M6 X 1 3/4" ( 45mm ) - 17 pcs  
Spare - 2 pcs

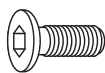
- C**  JCB M6 X 5/8" ( 15mm ) - 6 pcs  
Spare - 2 pcs  
Fix L Bracket to Front Panel

- D**  Barrel Nut - 4 pcs  
Spare - 1 pc  
For JCB M6 X 2"(50mm)

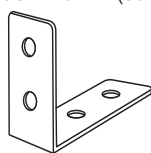
- E**  L Bracket - 3 pcs

- F**  Allen wrench - 1 pc  
Spare - 1 pc

# PARTS LIST

<b>01</b>	<b>HARDWARE</b>	<b>1 BOX</b>	<b>05</b>	<b>SIDE CROSS RAIL</b>	<b>2 PCS</b>
<b>02</b>	<b>FRONT PANEL</b>	<b>1 PC</b>	<b>06</b>	<b>CENTER CROSS RAIL</b>	<b>1 PC</b>
<b>03</b>	<b>FRONT RAIL</b>	<b>1 PC</b>	<b>07</b>	<b>BACK BOARD</b>	<b>2 PCS</b>
<b>04</b>	<b>BACK RAIL</b>	<b>1 PC</b>	<b>08</b>	<b>SLAT</b>	<b>2 SET</b>

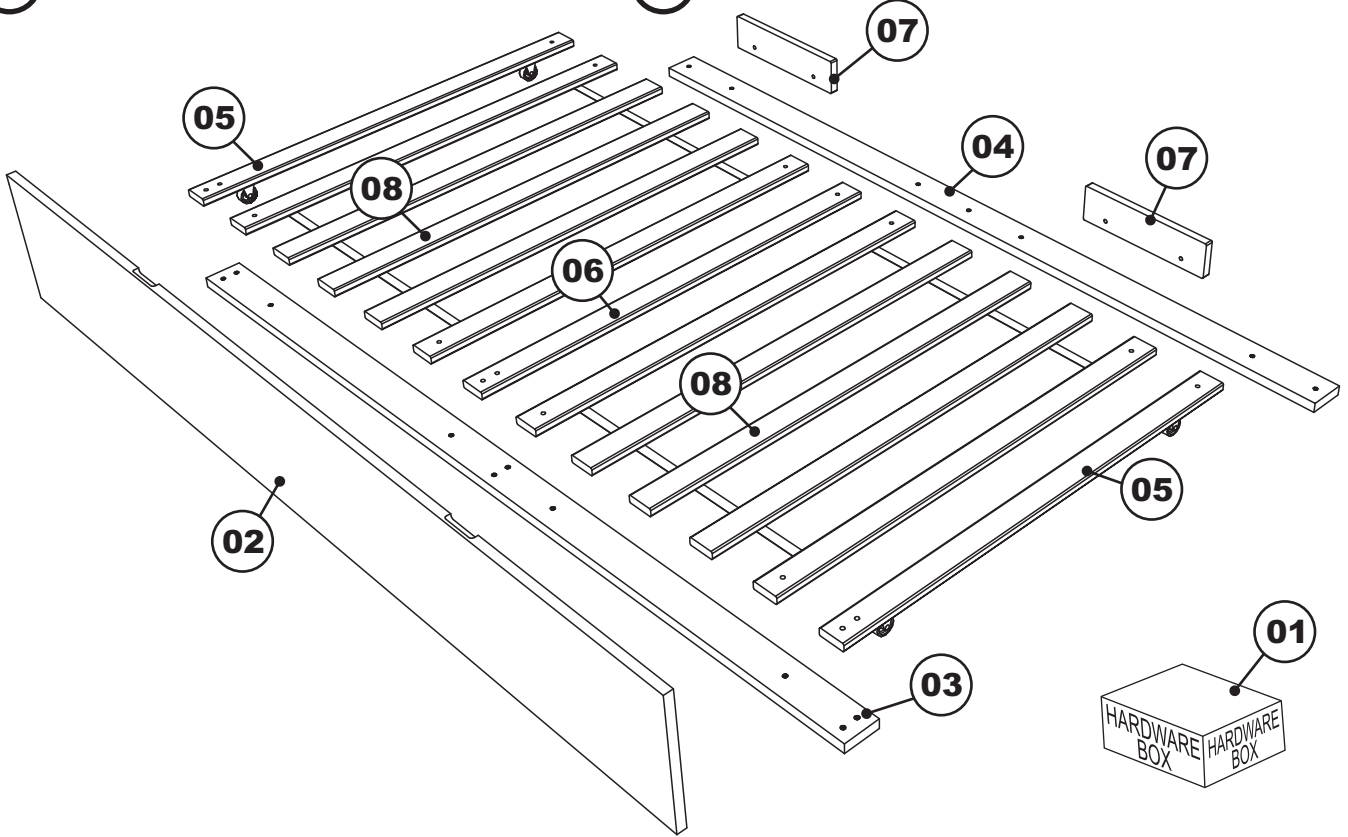

## STEP 1

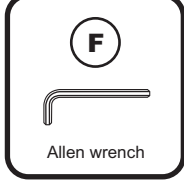
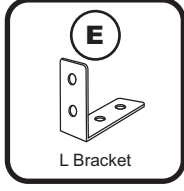
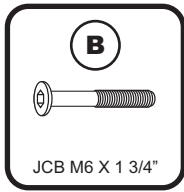
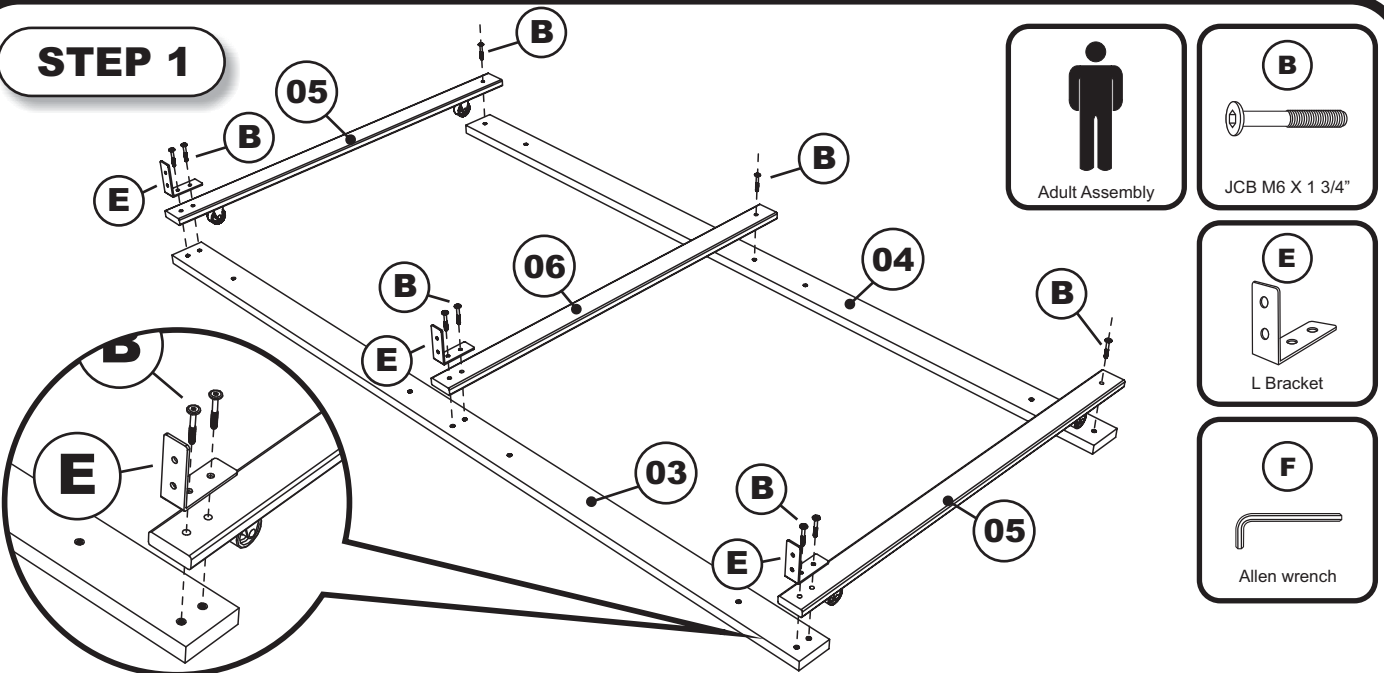

Attach the side cross rail (05) center cross rail (06) to the front and back rail (03)(04), using L bracket (E), JCB M6 X 1 3/4"(B). Tighten with the Allen wrench (F).

## STEP 2

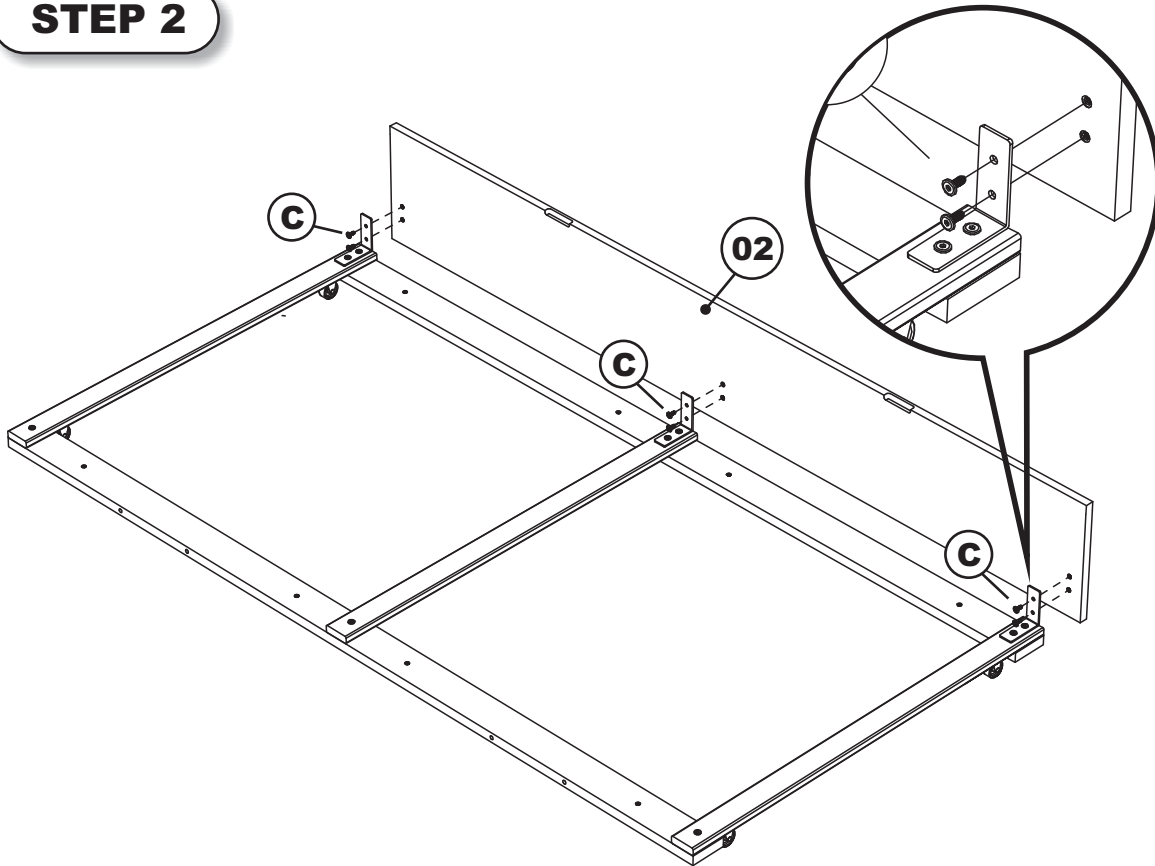

Adult Assembly

C



JCB M6 X 5/8"

F



Allen wrench

Attach the front panel (02) to the rail assemblies as shown, using JCB M6 X 5/8" (C).  
Tighten with the Allen wrench (F).

## STEP 3

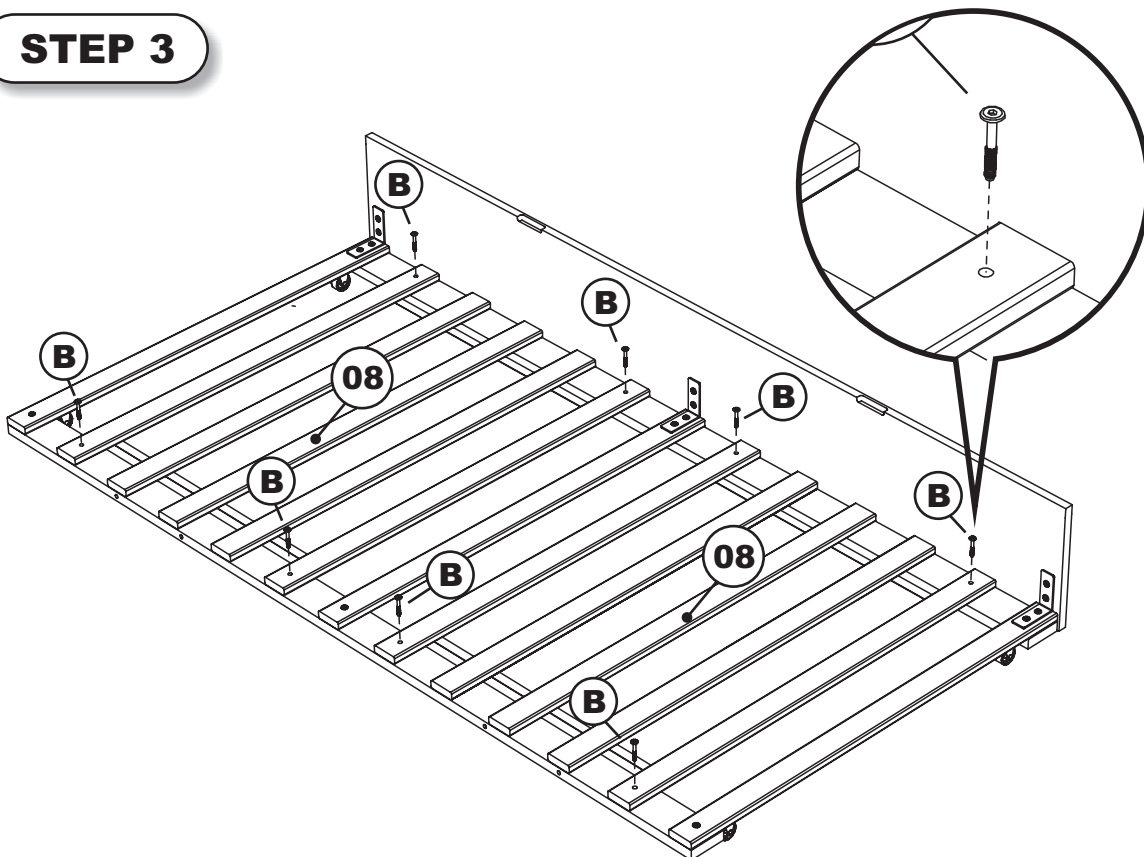

Adult Assembly

B

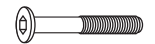

JCB M6 X 1 3/4"

F



Allen wrench

Lay the slat kit (08) onto the rail assemblies as shown, using JCB M6 X 1 3/4" (B).  
Tighten with the Allen wrench (F).

## STEP 4

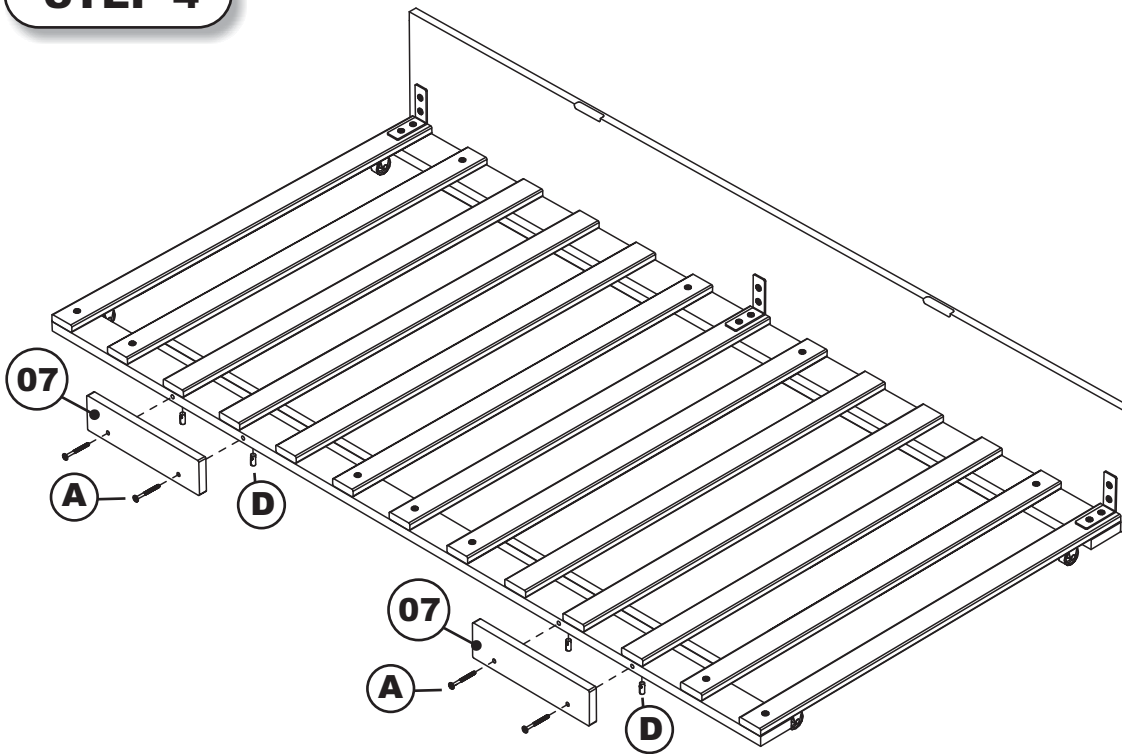

Adult Assembly

A



JCB M6 X 2 3/8"

D



Barrel Nut

F



Allen wrench

Attach the back boards (07) to the rail assemblies as shown. Using JCB M6 X 2 3/8"(A) barrel nut (D), tighten with the Allen wrench (F)

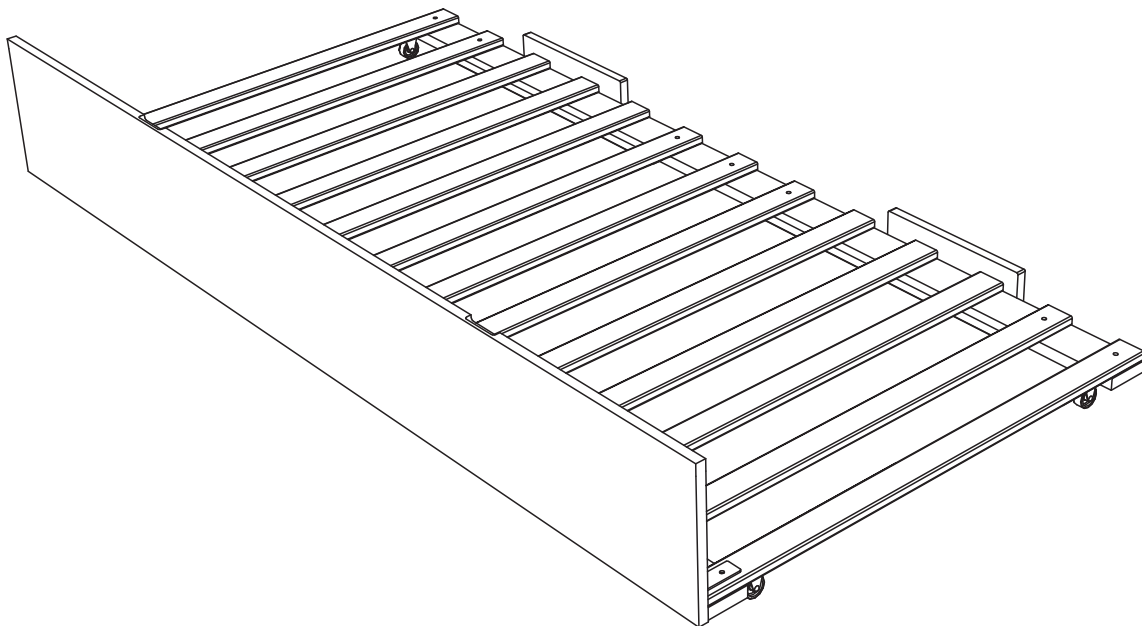

### Congratulations !

Your Trundle Bed is now ready for use.  
We recommend that you periodically check that all screws are tight  
and all parts are secure to ensure lasting safety.