

# ASSEMBLY INSTRUCTION

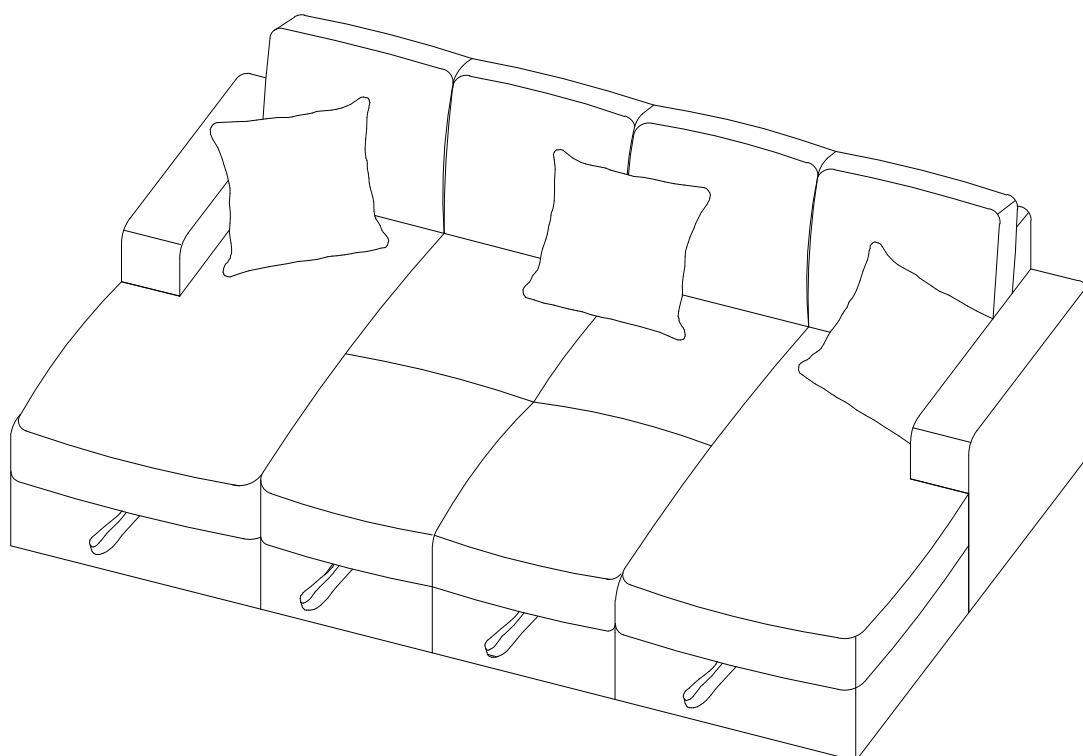

## ASSEMBLY RATING

The Assembly Rating is a 5-point system that shows the degree of effort needed in assembling a specific product (with 1 being easy and 5 being relatively difficult). For some products, two persons are recommended.

EASY



DIFFICULT

**Do not tighten screws until completely assembled.**

# ASSEMBLY & CARE ADVICE

FOR YOUR FURNITURE TO LAST, CORRECT ASSEMBLY AND PROPER MAINTENANCE ARE NECESSARY. PLEASE FOLLOW THE INFORMATION PROVIDED BELOW TO FULLY ENJOY YOUR FURNITURE.

## BASIC ASSEMBLY TECHNIQUES

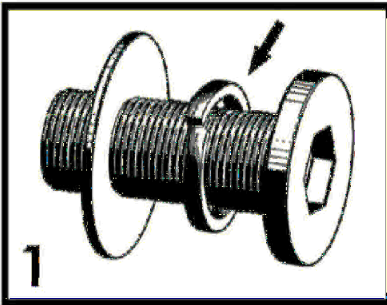

1  
When lock or spring washer is used in an assembly, please make sure the lock or spring washer is placed between the larger flat washer and the head of the screw or bolt.

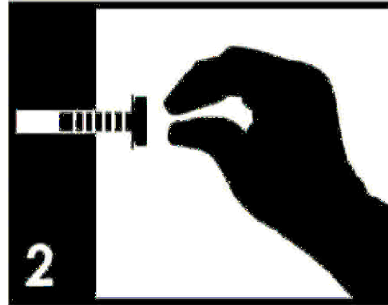

2  
Position each part correctly and insert screws or bolts into their respective holes by hand tighten or using the proper hand tool. Only tighten when step is completed or when instructed to do so.

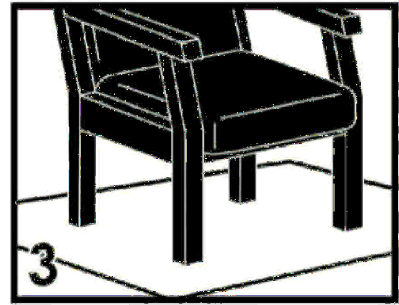

3  
Use cardboard or carpet area when assembling furniture to prevent scratches. Make sure the furniture rests on a flat and level surface with each leg evenly touching the floor. No dragging of products/parts.

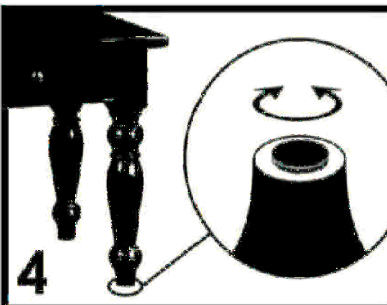

4  
Some furniture comes with height adjustment knobs underneath each leg. To lower or to raise each leg, you need to turn clockwise or counterclockwise, respectively.

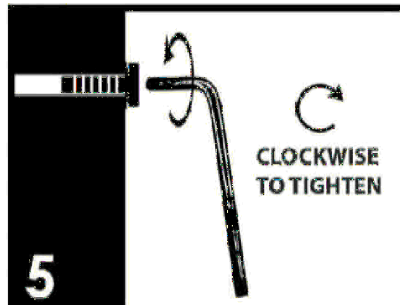

5  
Make sure all parts are properly aligned, then use the appropriate hand tool to completely tighten the bolts or screws. Do not use power tools and do not overtighten.

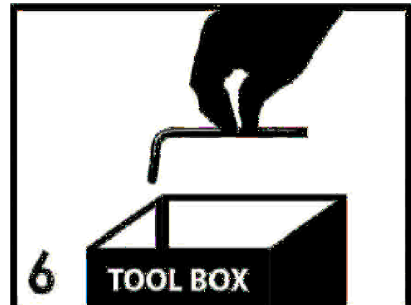















6  
Save the instructions and store the Allen wrench or any supplied tool for later maintenance. After two weeks, check and tighten any loose hardware and repeat again every six months thereafter.

IT IS THE USER'S RESPONSIBILITY TO MAINTAIN THE FURNITURE. THE HARDWARE MAY LOOSEN OVER TIME AND MAY CAUSE THE FURNITURE TO BE WOBBLY AND UNABLE TO SUPPORT ITS INTENDED WEIGHT CAPACITY. THIS MAY LEAD TO COLLAPSE AND MAY CAUSE SERIOUS INJURY.



**FAILURE TO FOLLOW THE GUIDELINES ABOVE MAY RESULT IN INJURY AND/OR PROPERTY DAMAGE.**

PARTS IDENTIFICATION			
NO	Shape	Specification	Quantity
A		RIGHT CHAISE	1PC
B		RIGHT ARM	1PC
C		SHORT BACKREST	2PCS
D		BACK CUSHION	4PCS
E		LOVESEAT	1PC
F		LONG BACKREST	1PC
G		LEFT CHAISE	1PC
H		LEFT ARM	1PC
I		PILLOW	3PCS

HARDWARE LIST			
NO	Shape	Specification	Quantity
1		ROUND LEG Φ50*50MM	8PCS
2		RECTANGLE LEG 150*50*50MM	10PCS
3		MALE BRACKET	6PCS
4		ROTATING WHEEL	4PCS
5		SCREW #8 x 45mm	28PCS
6		SCREW #8 x 25mm	16PCS



Not included  
No Se Adjunto  
Non indus

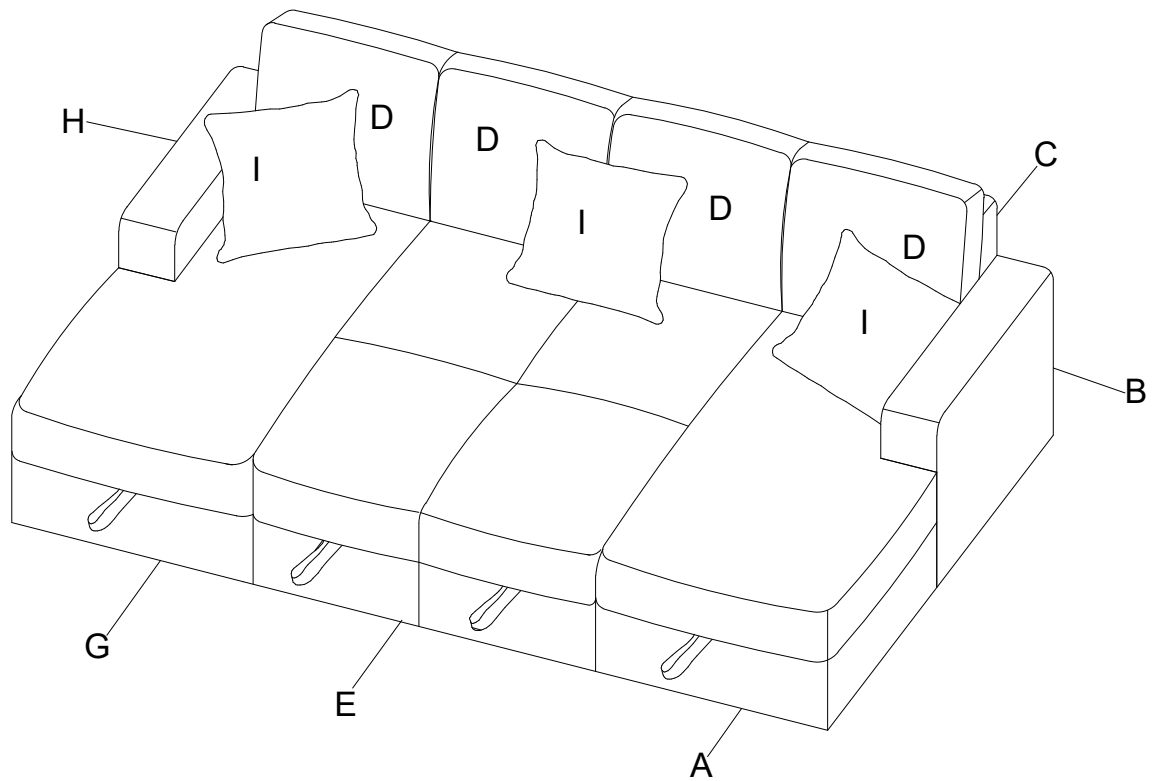

**Do not tighten screws until completely assembled.**

# STEP 1

NOTE: ASSEMBLY INSTRUCTION FOR MULTIPLE UNITS.  
THE PARTS/LABEL INDEX ARE SEPARATED FOR DIFFERENT UNITS  
THE PARTS ARE LOCATED INSIDE THE BOX AS BELOW

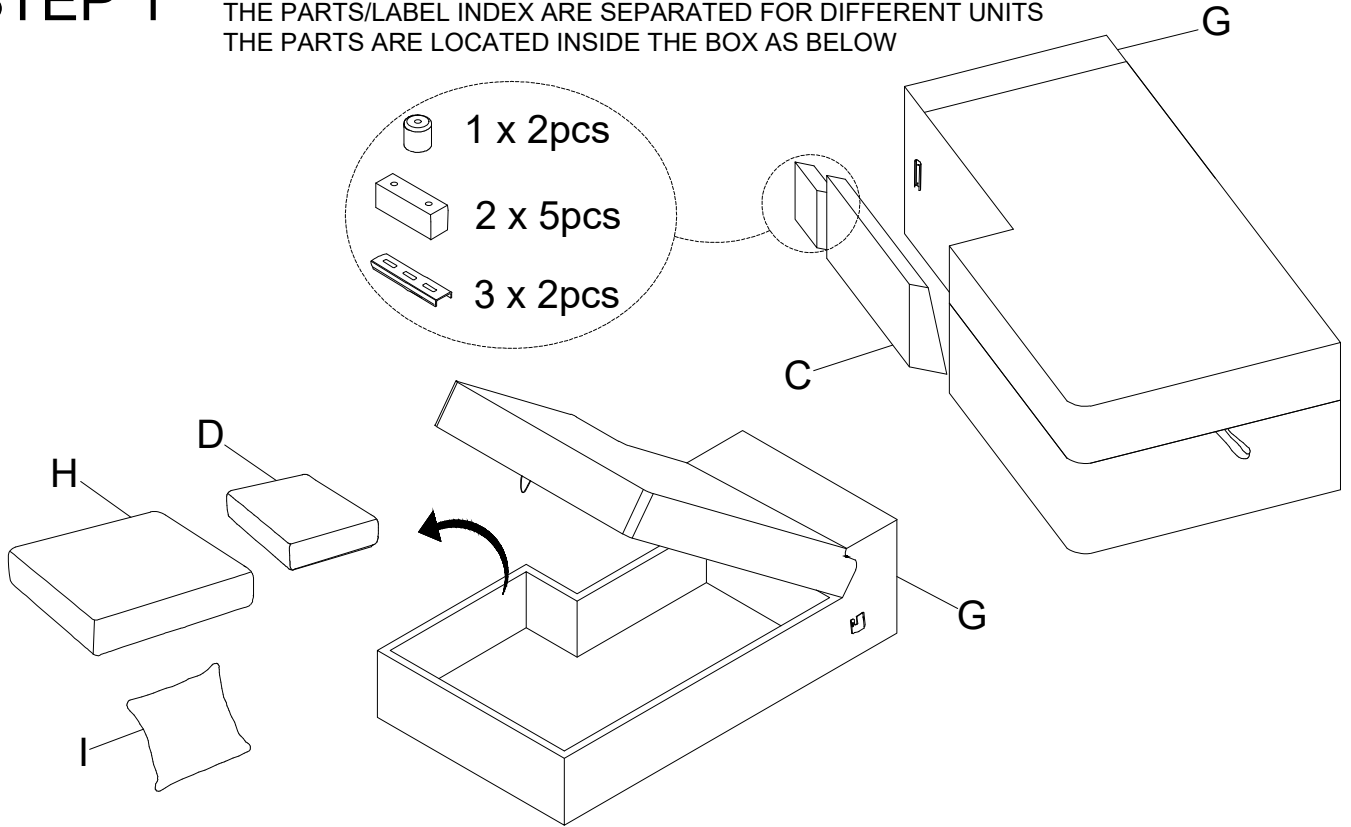

# STEP 2

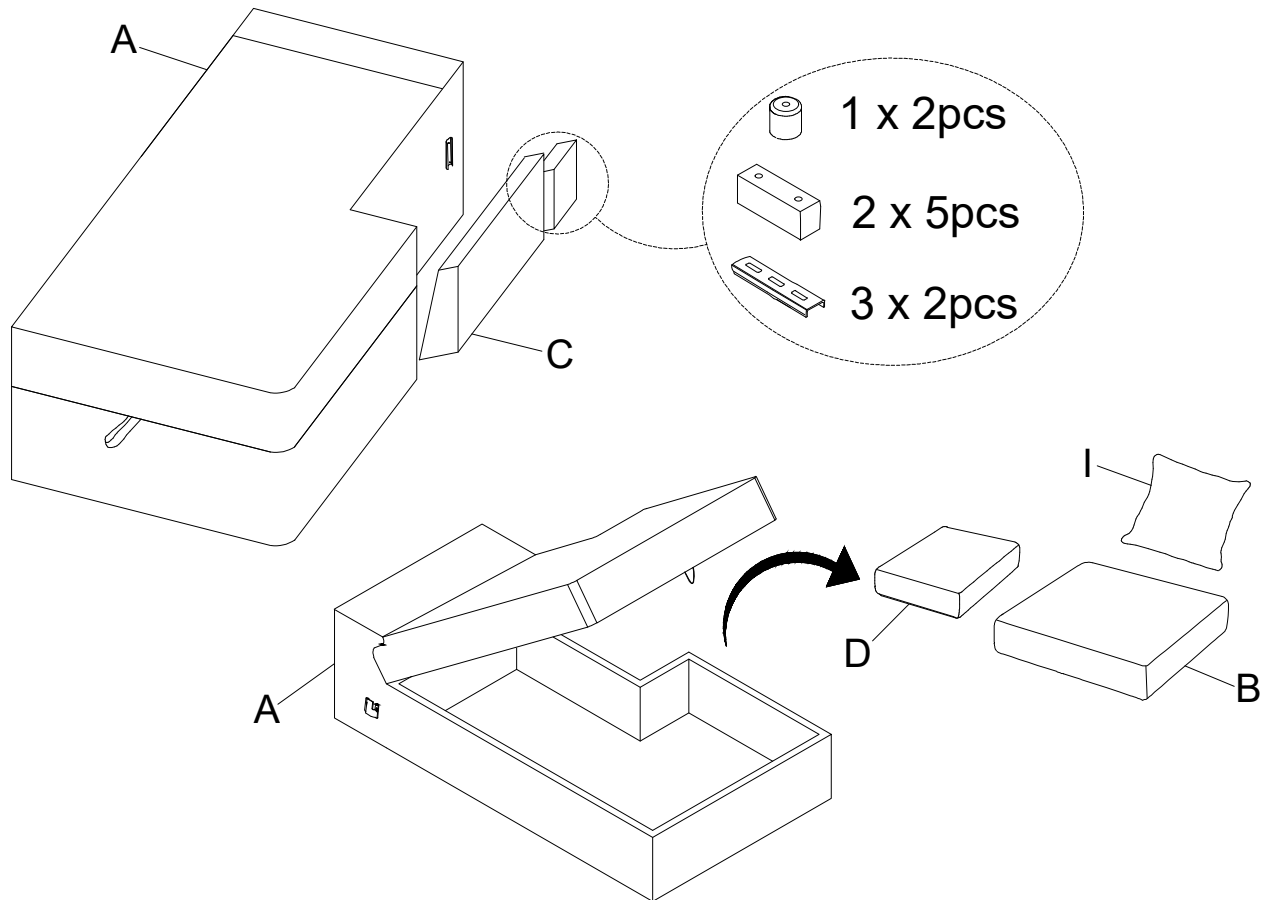

**Do not tighten screws until completely assembled.**

## STEP 3

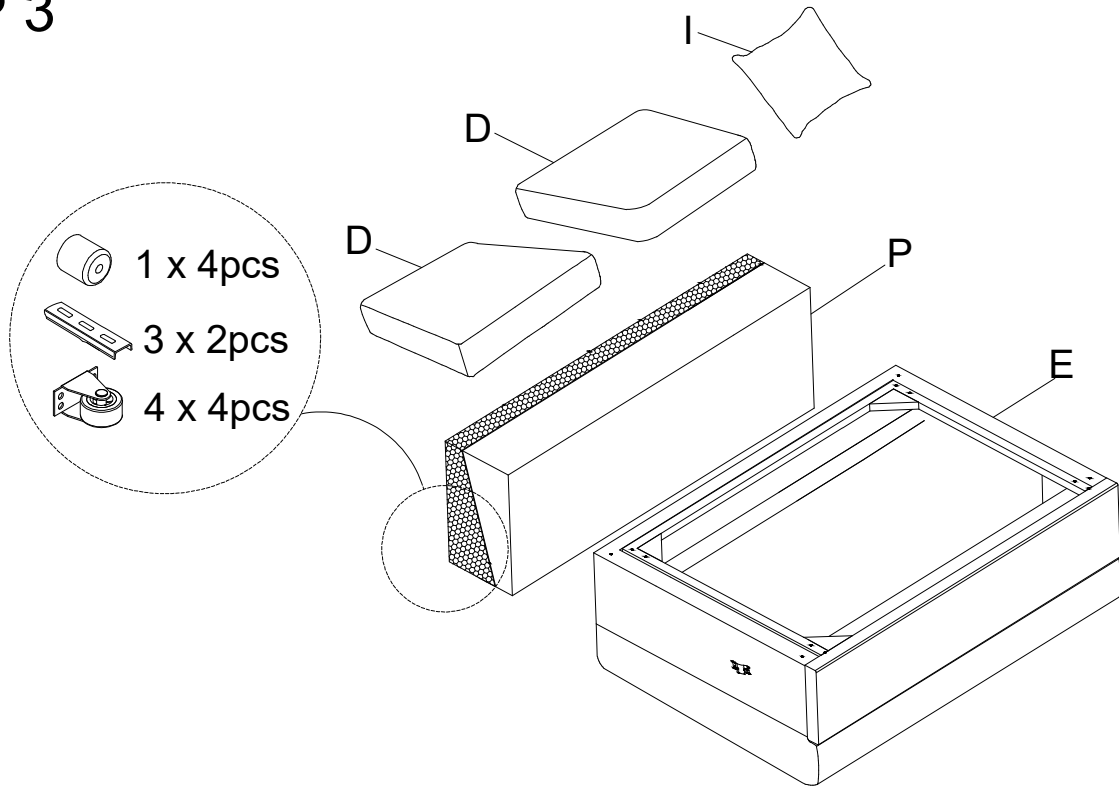

## STEP 4

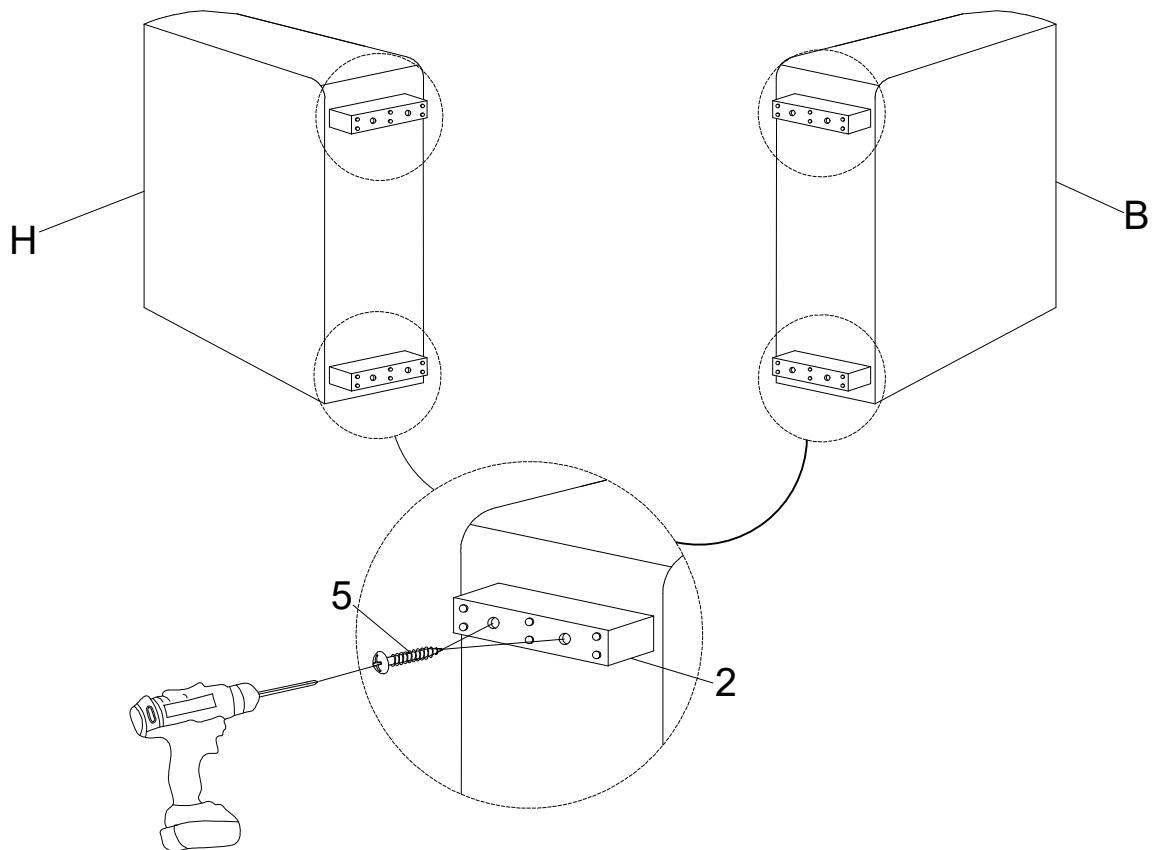

**Do not tighten screws until completely assembled.**

## STEP 5

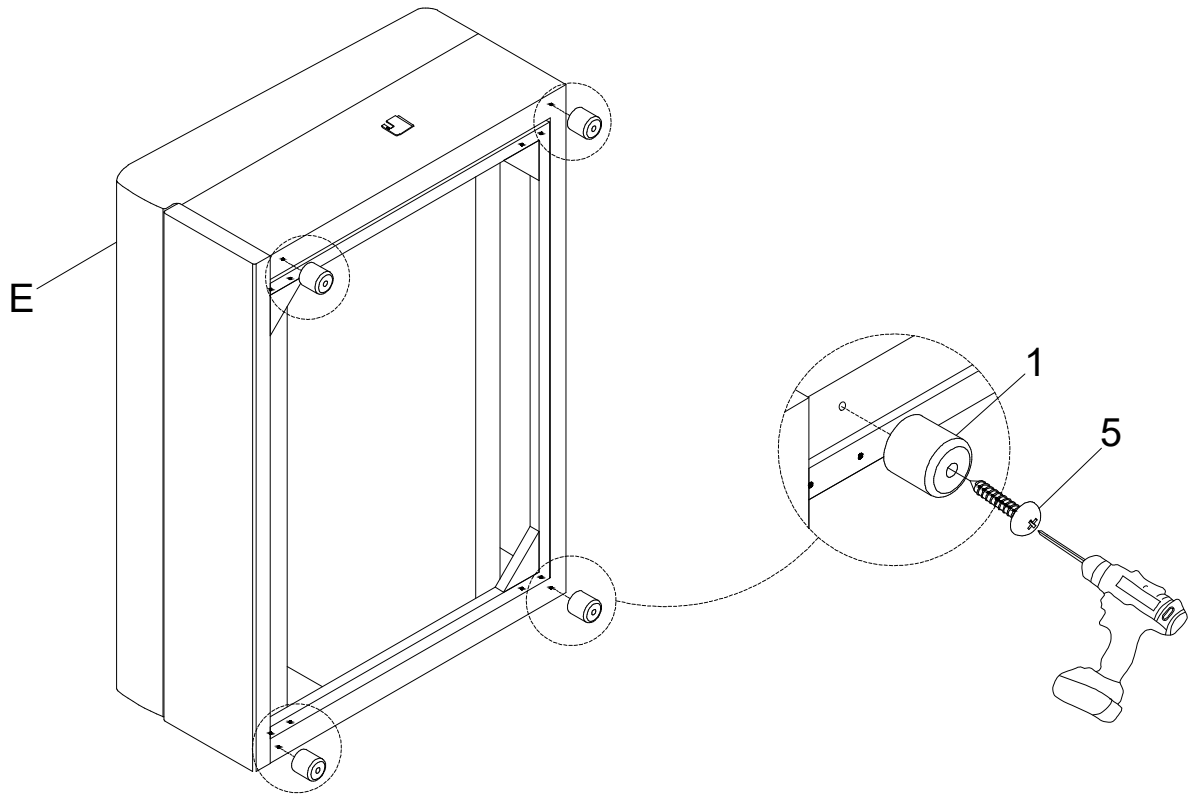

## STEP 6

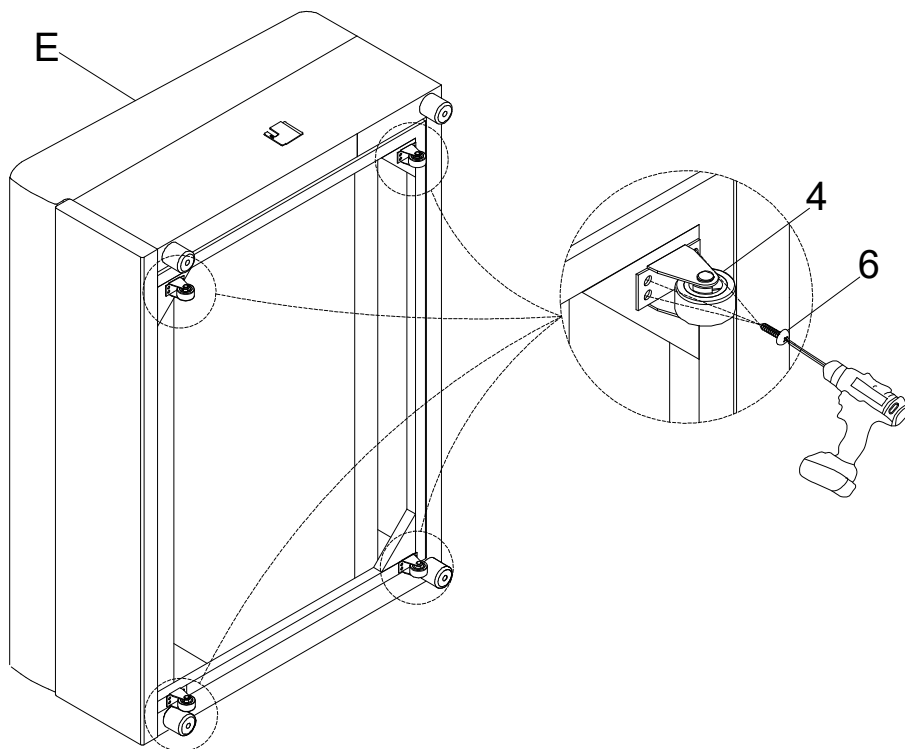

**Do not tighten screws until completely assembled.**

## STEP 7

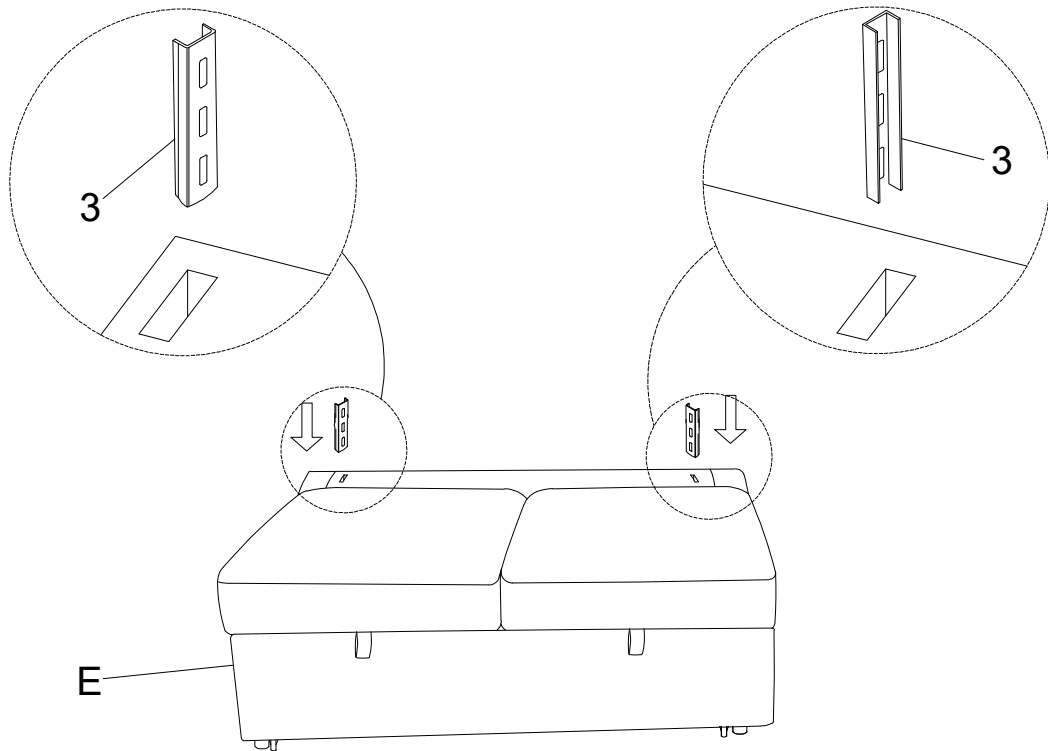

## STEP 8

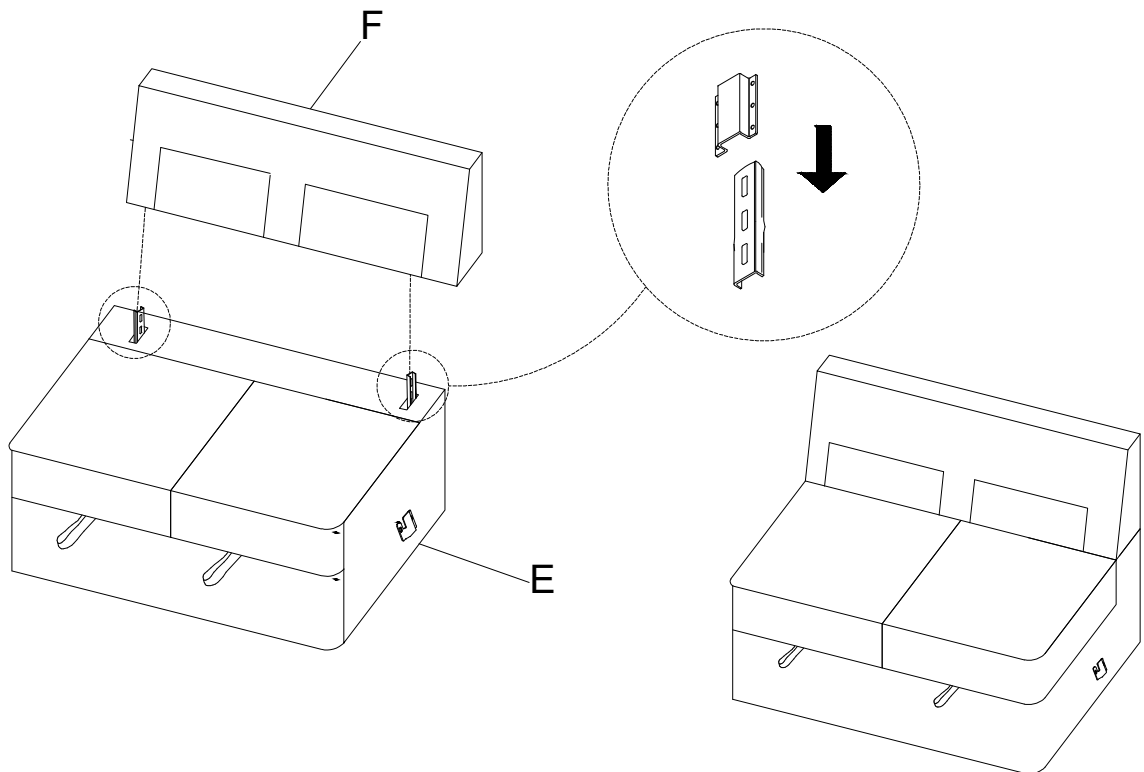

**Do not tighten screws until completely assembled.**

# STEP 9

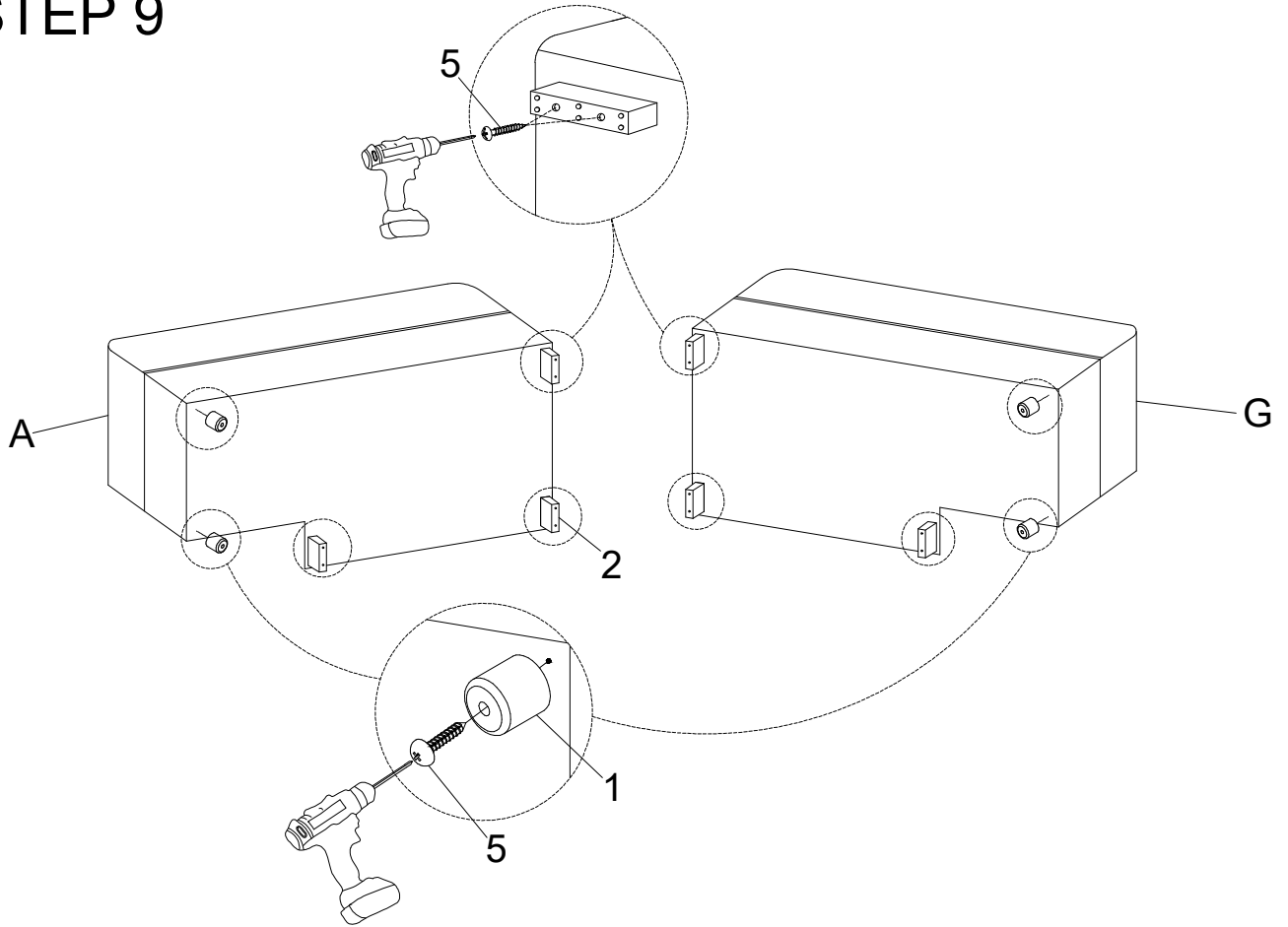

# STEP 10

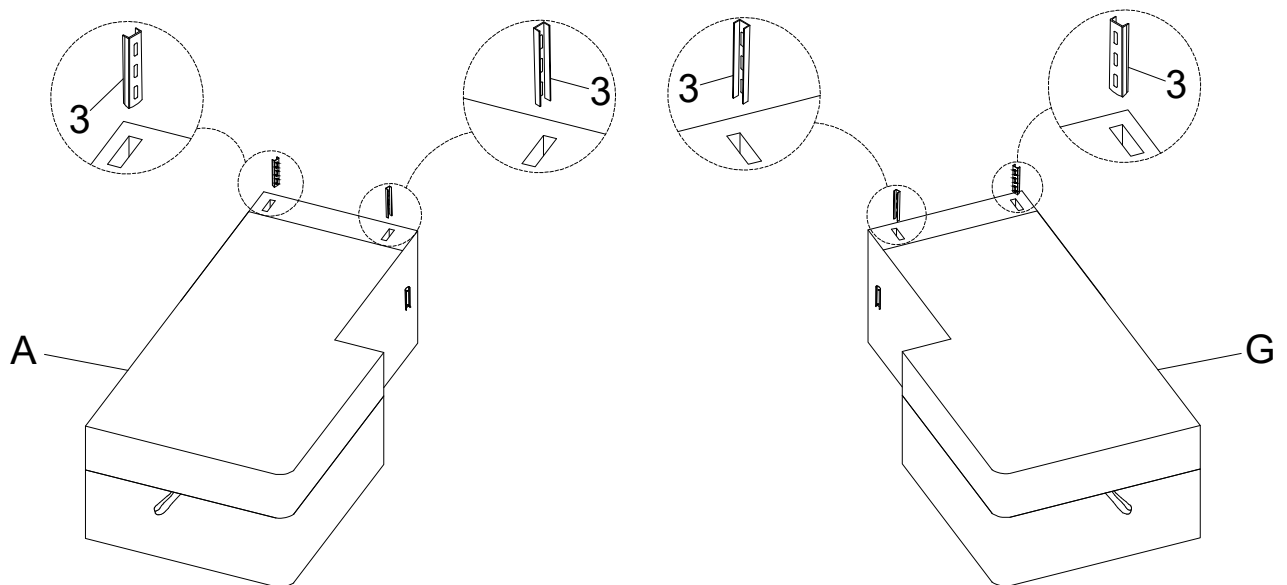

**Do not tighten screws until completely assembled.**

## STEP 11

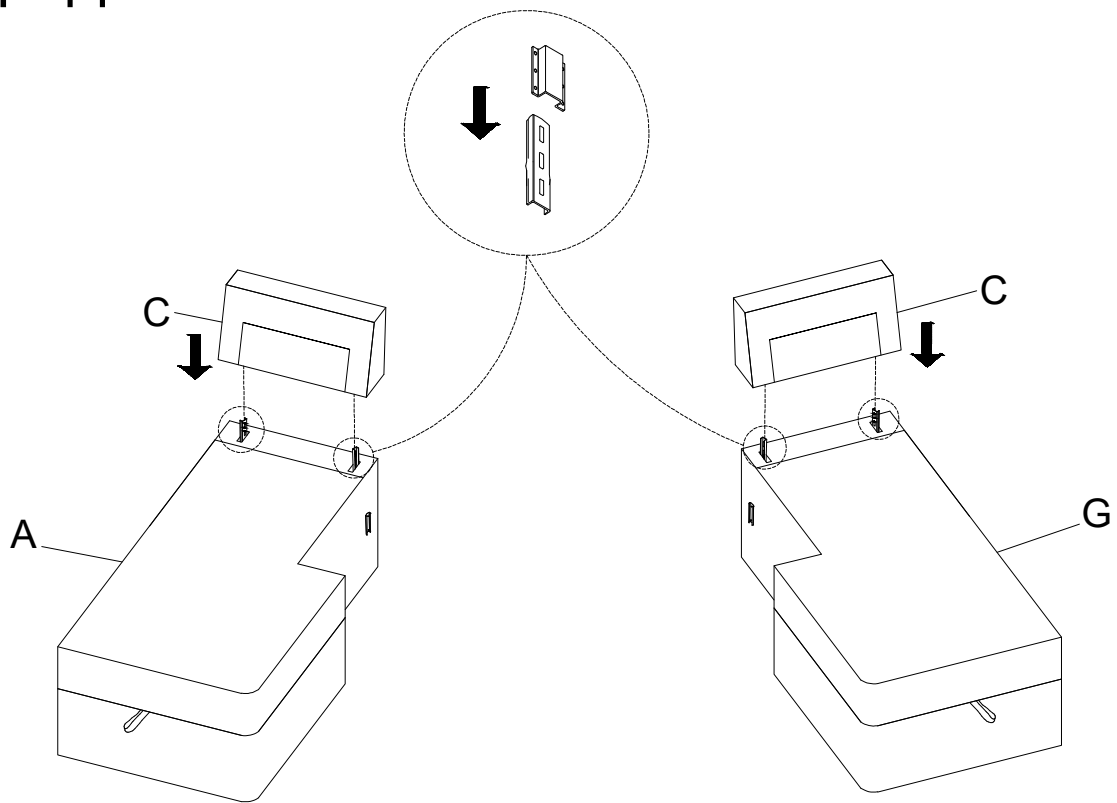

## STEP 12

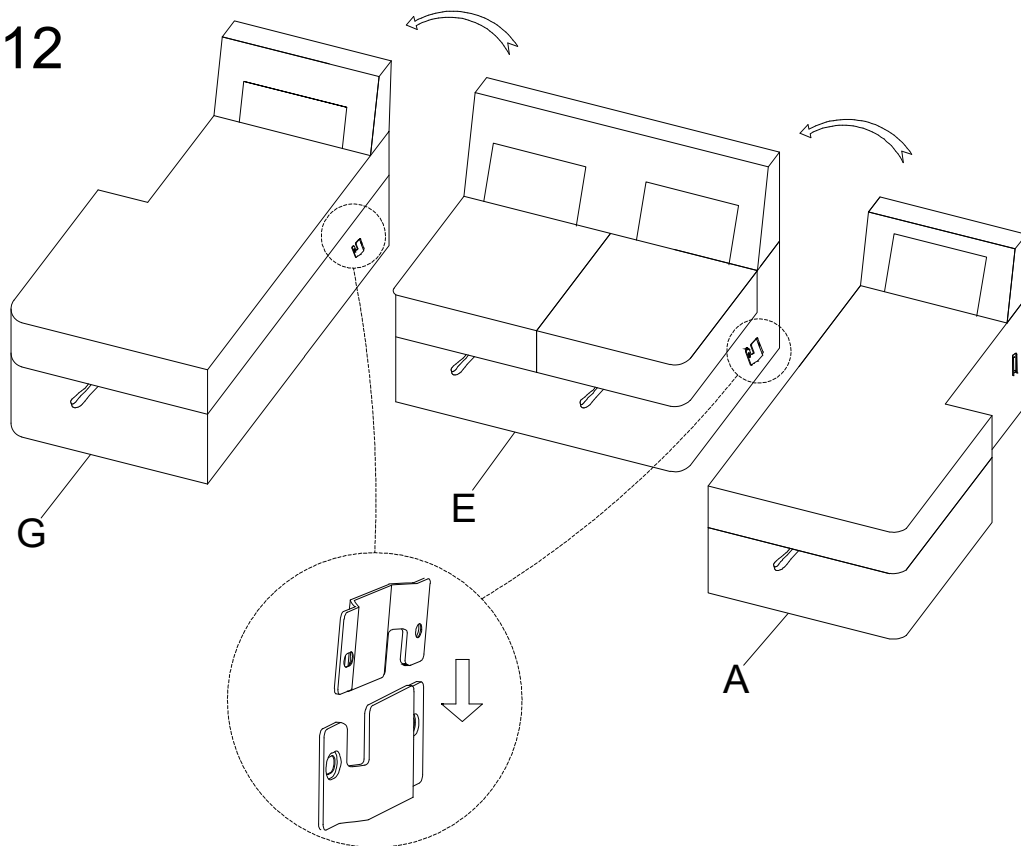

**Do not tighten screws until completely assembled.**

## STEP 13

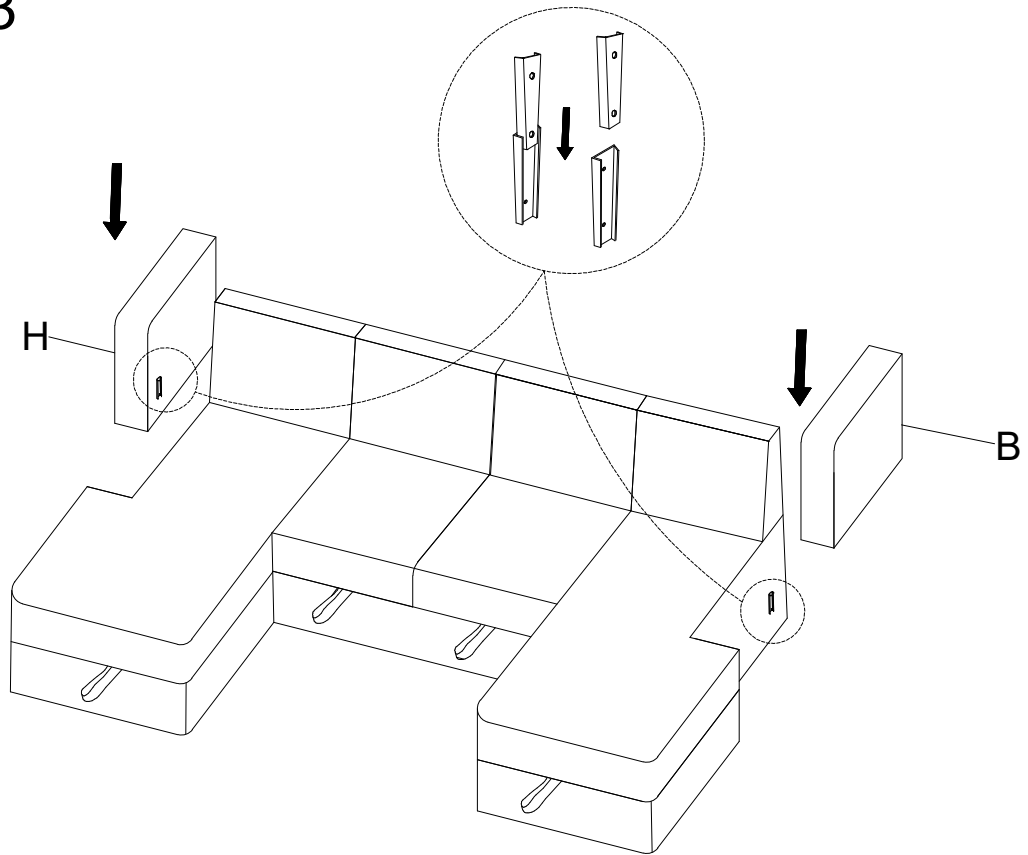

## STEP 14

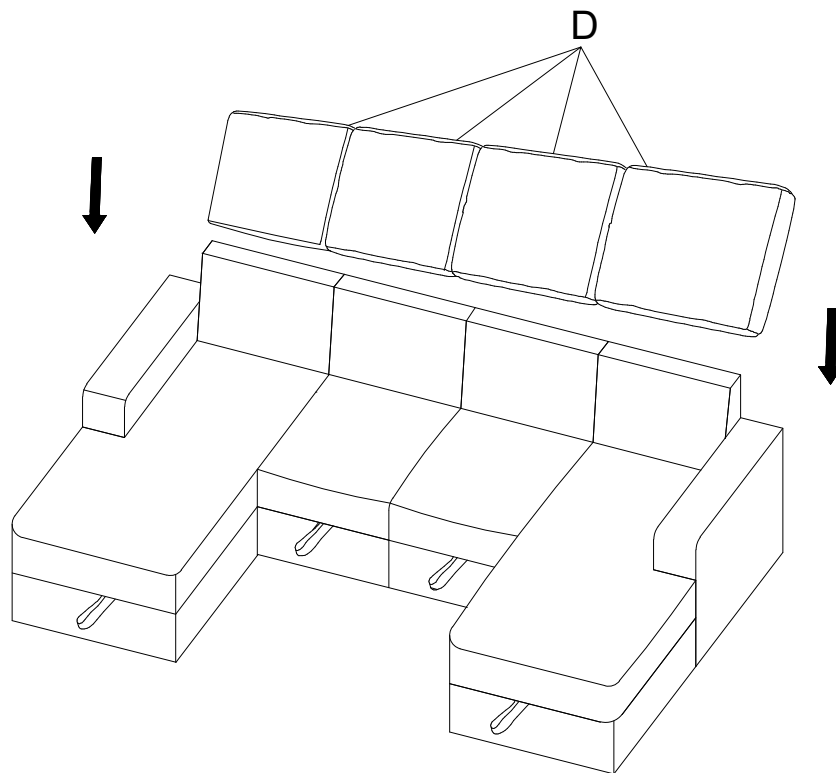

**Do not tighten screws until completely assembled.**

# STEP 15

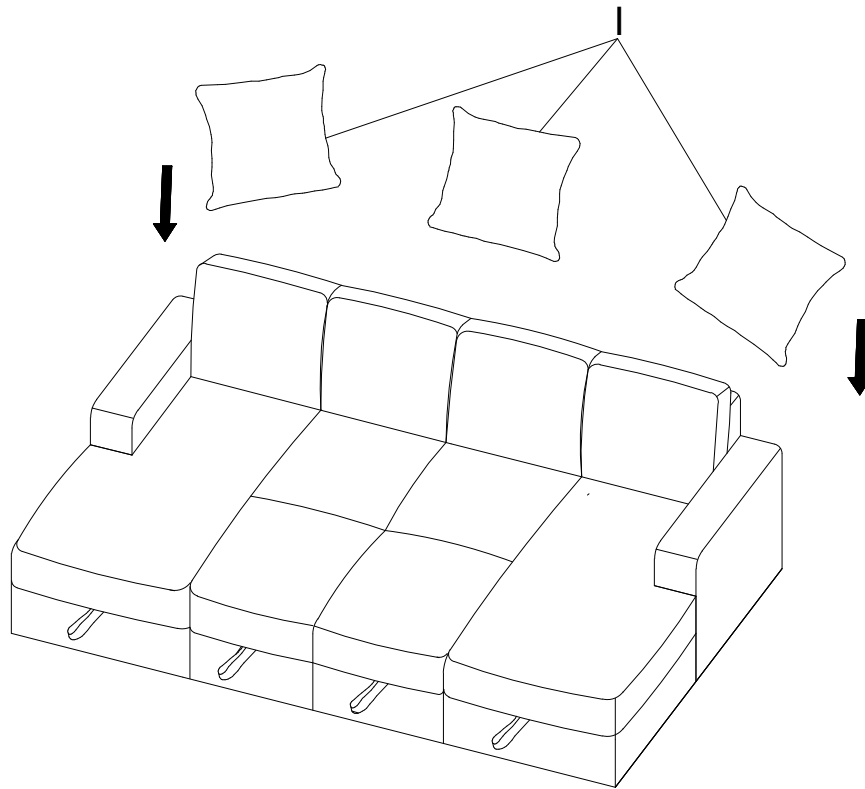

# STEP 16

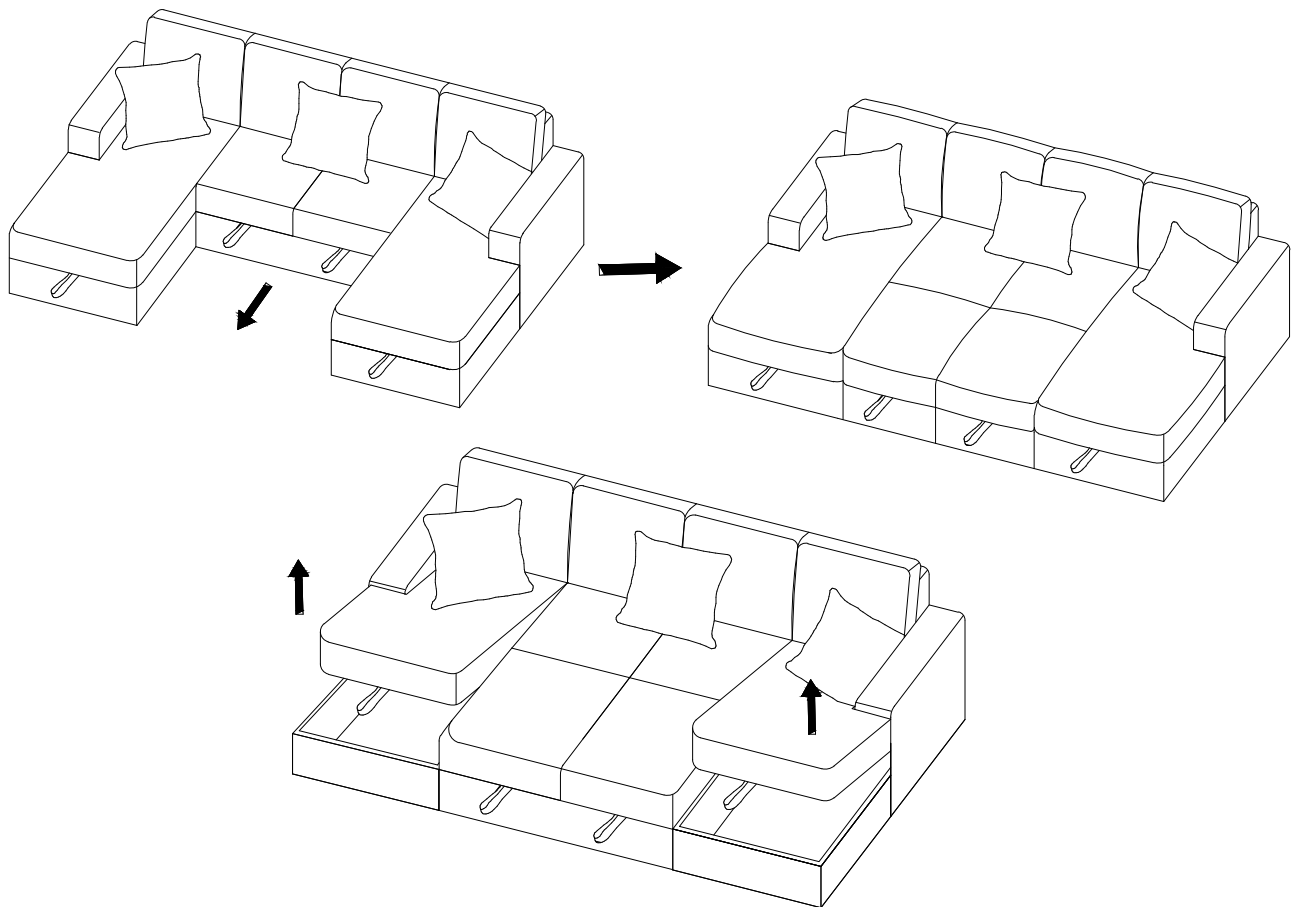

**Do not tighten screws until completely assembled.**