

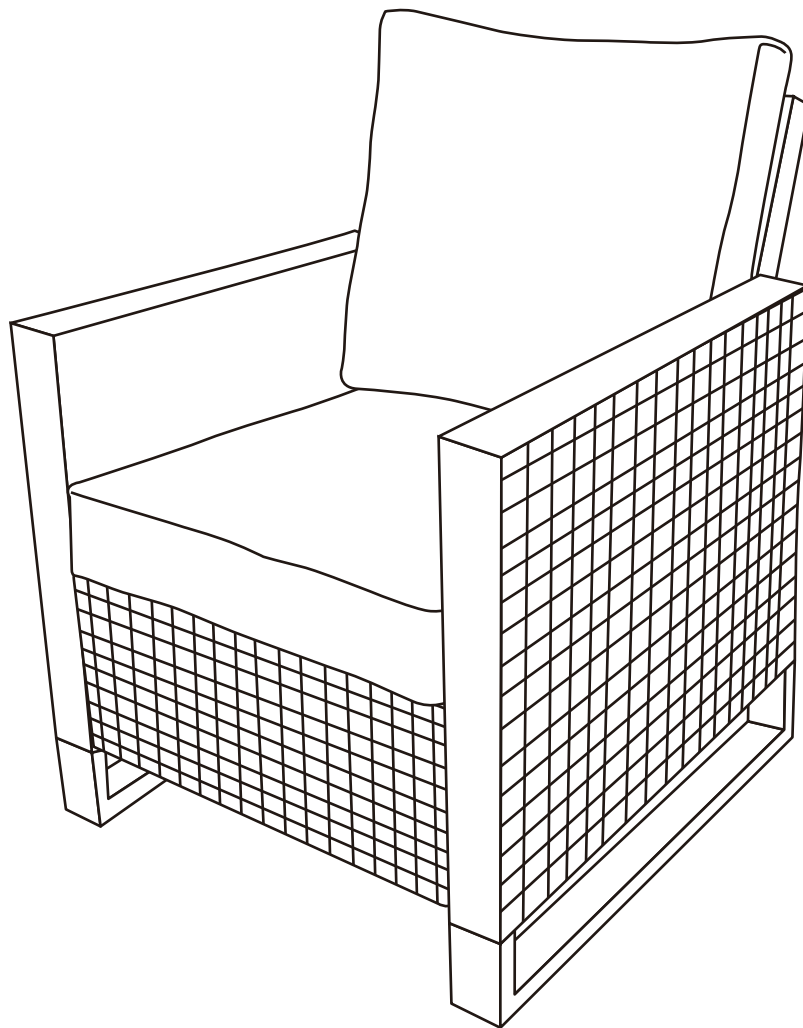

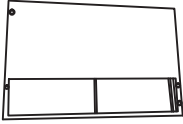

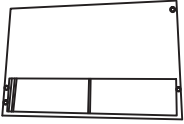



ASSEMBLY INSTRUCTION

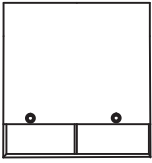
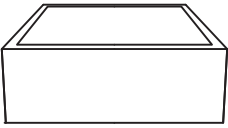
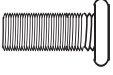

Part No.	Part	Qty	Image	Part No.	Part	Qty	Image
A1	Left Arm	1		A2	Right Arm	1	
B	Feet	2		C	Back	1	
D	Seat	1		E	Bolt	8	 M6 * 20MM
F	Bolt	6	 M6 * 35MM	G	Bolt	2	 M6 * 40 MM
H	Bolt	2	 M6 * 95MM	I	Washer	18	
J	Back Cushion	1		K	Seat cushion	1	
L	Wrench	1					

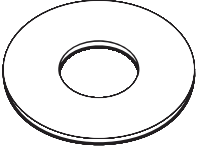
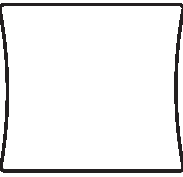
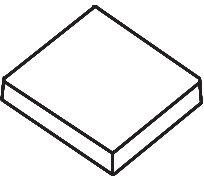
STEP 1

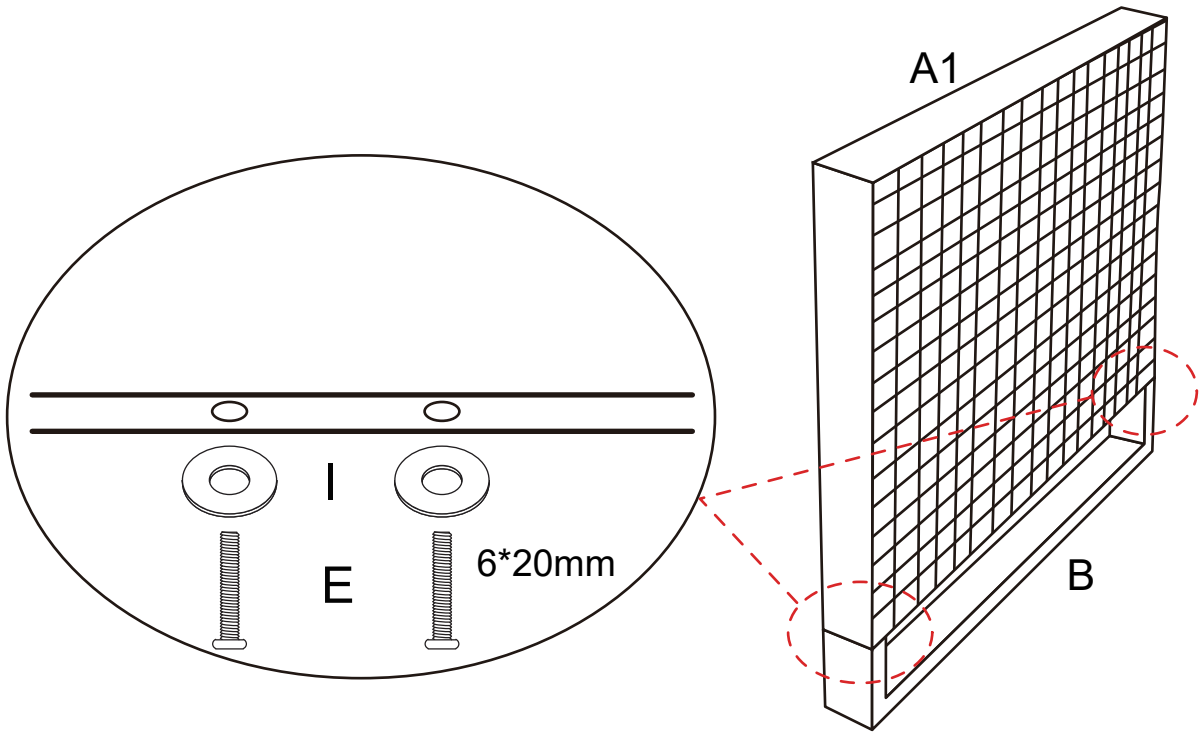

Attach left arm and feet with E and I. Don't tighten bolts!
Attach right arm and feet in the same way.

STEP 2

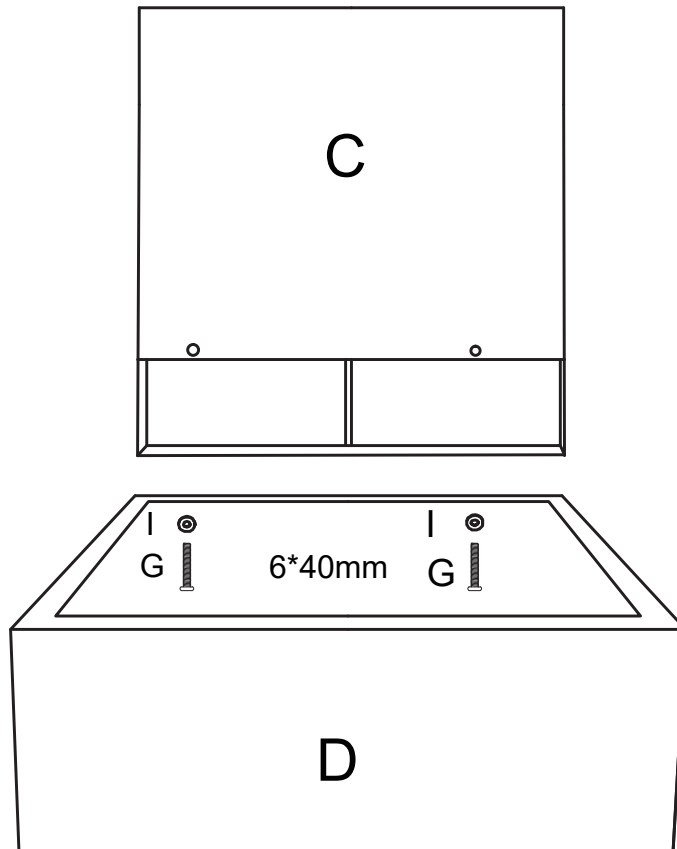

Attach seat and back with G and I. Don't tighten bolts!

STEP 3

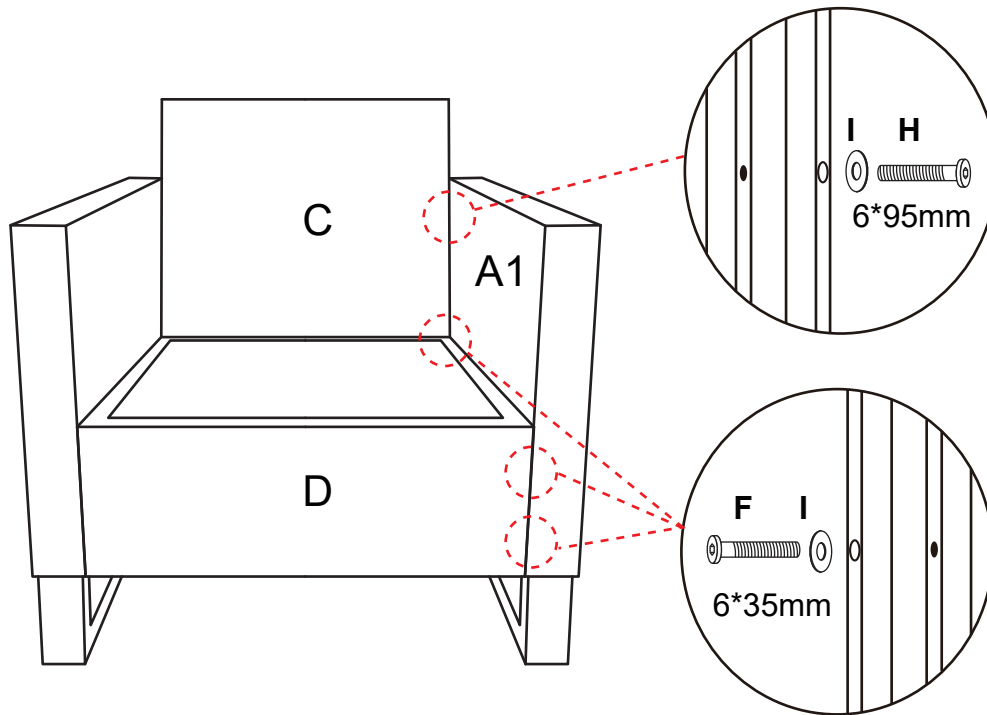

Attach left arm and back with H and I. Don't tighten bolts!

Attach left arm, back and seat with F and I. Don't tighten bolts!

Attach right arm in the same way. Tighten all the bolts!

STEP 4

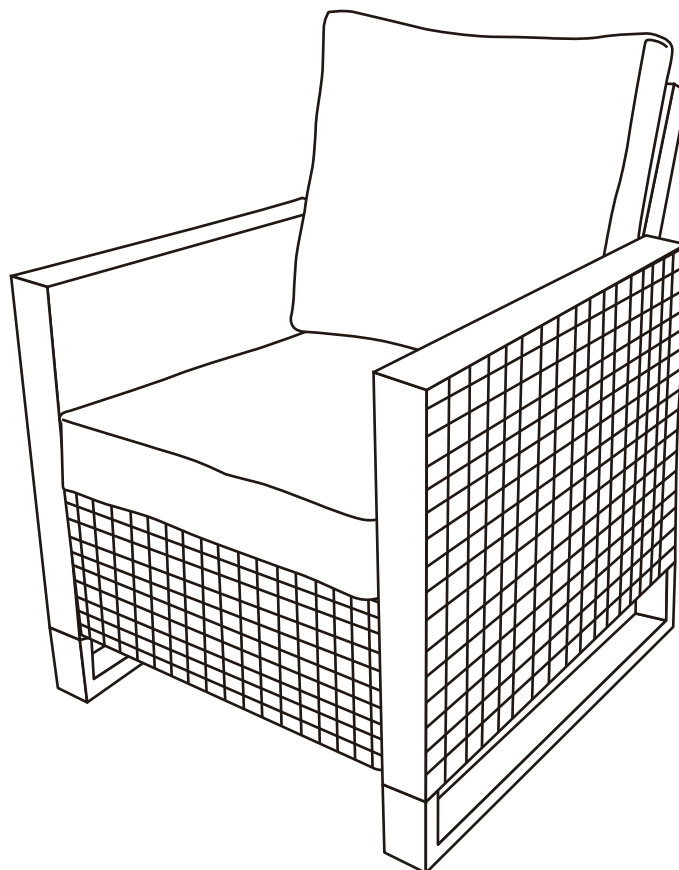

Put seat and back cushions on the chair.