

Assembly Instructions

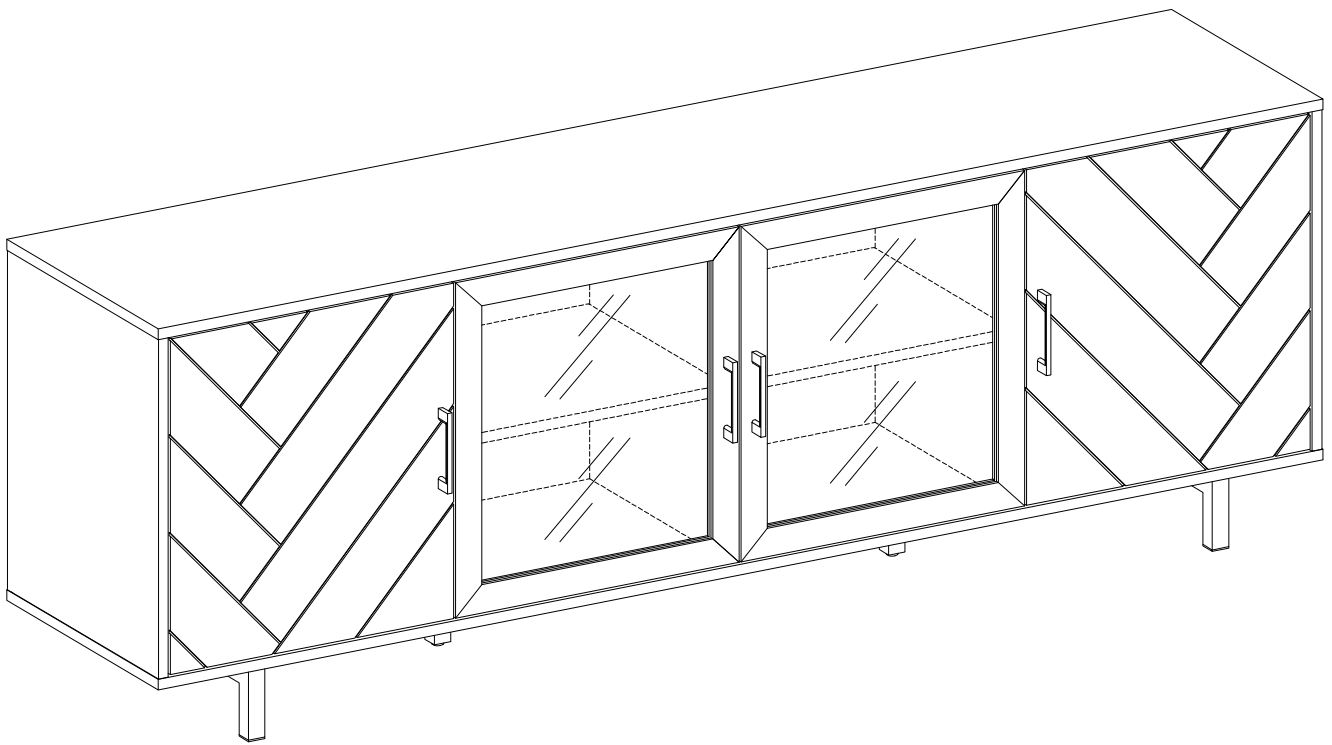

General Assembly Guidelines

- I. Ensure that all parts and hardware are available before beginning assembly.
- II. Follow each step carefully to ensure the proper assembly of this product.
- III. Two people are recommended for ease in the assembly of this product.
- IV. The three main types of hardware used to assemble this product are: wood dowels, screws and bolts.
- V. The provided glue is to secure wood dowels in place. When first inserting dowels, locate the appropriate hole for the dowel, place a small amount of glue in the hole and insert the dowel. Wipe away excess glue immediately.

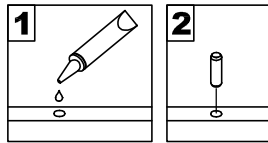

In future assembly steps when dowels are necessary to attach assembly parts together, place a small amount of glue on the end of the dowel before attaching parts together. Wipe away excess glue immediately.

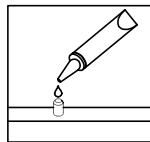

- VI. A Phillips head screwdriver is required for the assembly of this product.

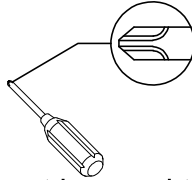

- VII. Power tools should not be used to assemble this product.

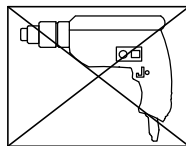

- VIII. Drill may be needed for securing product to wall.
- IX. Concealed hinges are three-way adjustable.

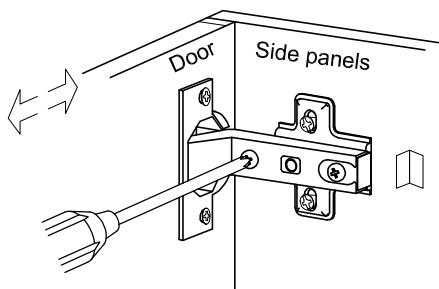

Horizontal
by screw adjustment

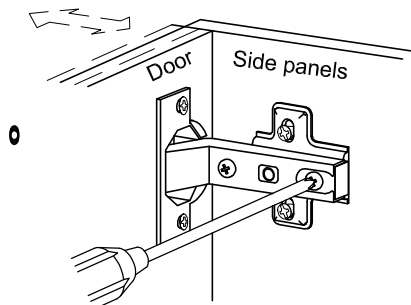

In-and-Out
by loosening the hinge-arm
mounting screw or via cam
adjustment

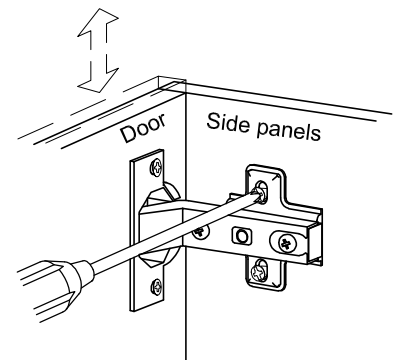





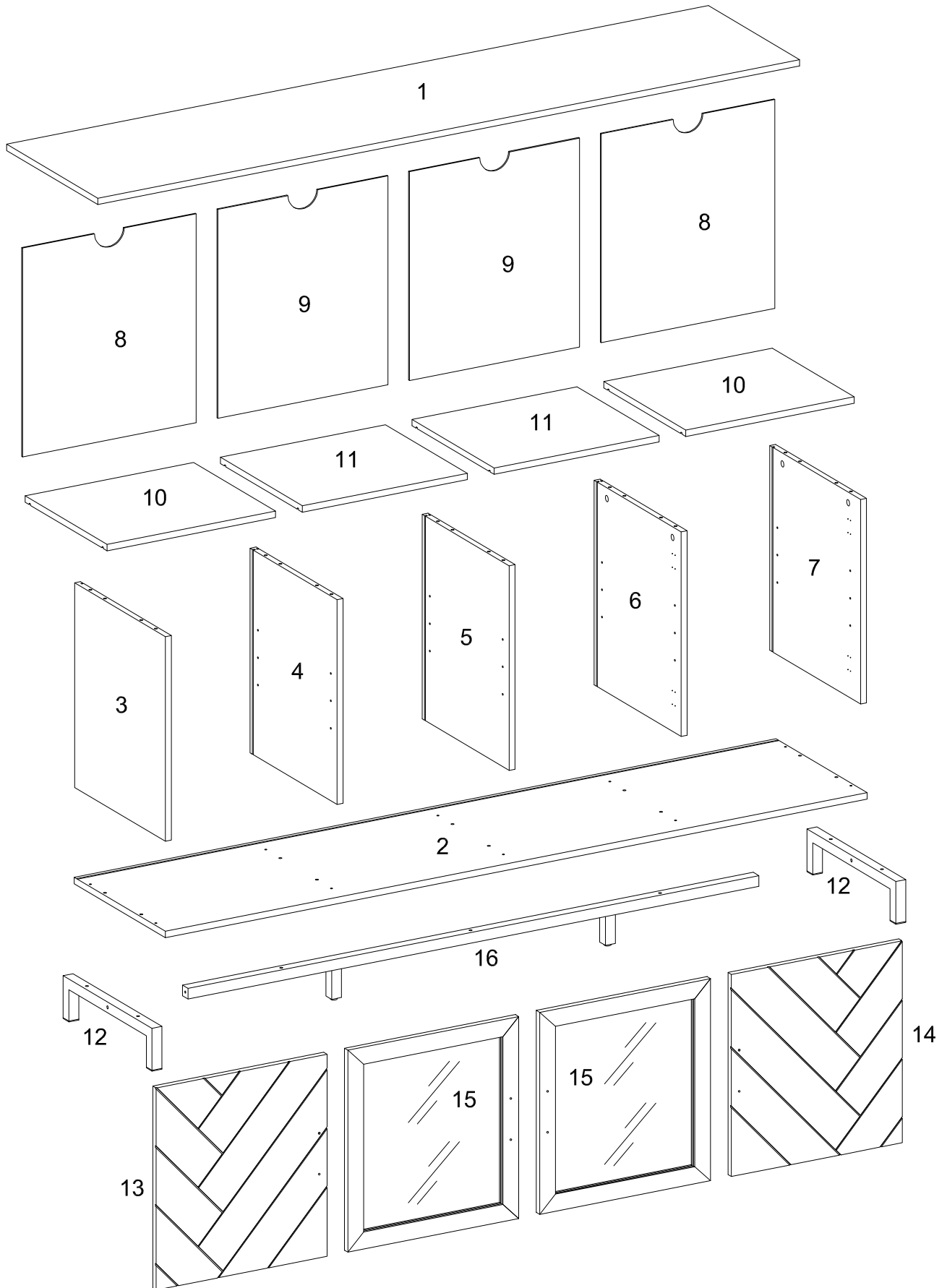







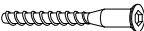



Vertical
Via slots in the mounting
plate or via cam adjustment

Parts List



Hardware List

A		Ø8x30mm	Wooden dowel	20 pcs
B		Ø6x35mm	Cam bolt	10 pcs
C		Ø15x11mm	Cam lock	10 pcs
D		Ø30mm	Sticker	10 pcs
E		Ø6x50mm	Screw	10 pcs
F		Ø26	Europe Hinge	4 pcs
G		Ø4x14mm	Screw	48 pcs
H		Ø26	Europe Hinge	4 pcs
J		Ø6x35mm	Bolt	7 pcs
K		M4	Hex key	1 pc
L			Handle	4 pcs
M		Ø4x22mm	Bolt	8 pcs
N			Shelf support pin	16 pcs
P		Ø3x17mm	Screw	16 pcs
Q			Plastic wedge	16 pcs
R		Ø6x40mm	Bolt	2 pcs
S			Glue tube	1 pc

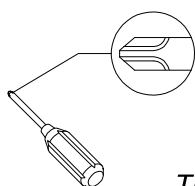

Philips head screwdriver required for assembly
(not included)

*The hardware quantities listed above are required for proper assembly.
Some extra hardware may also have been included.*

Step 1

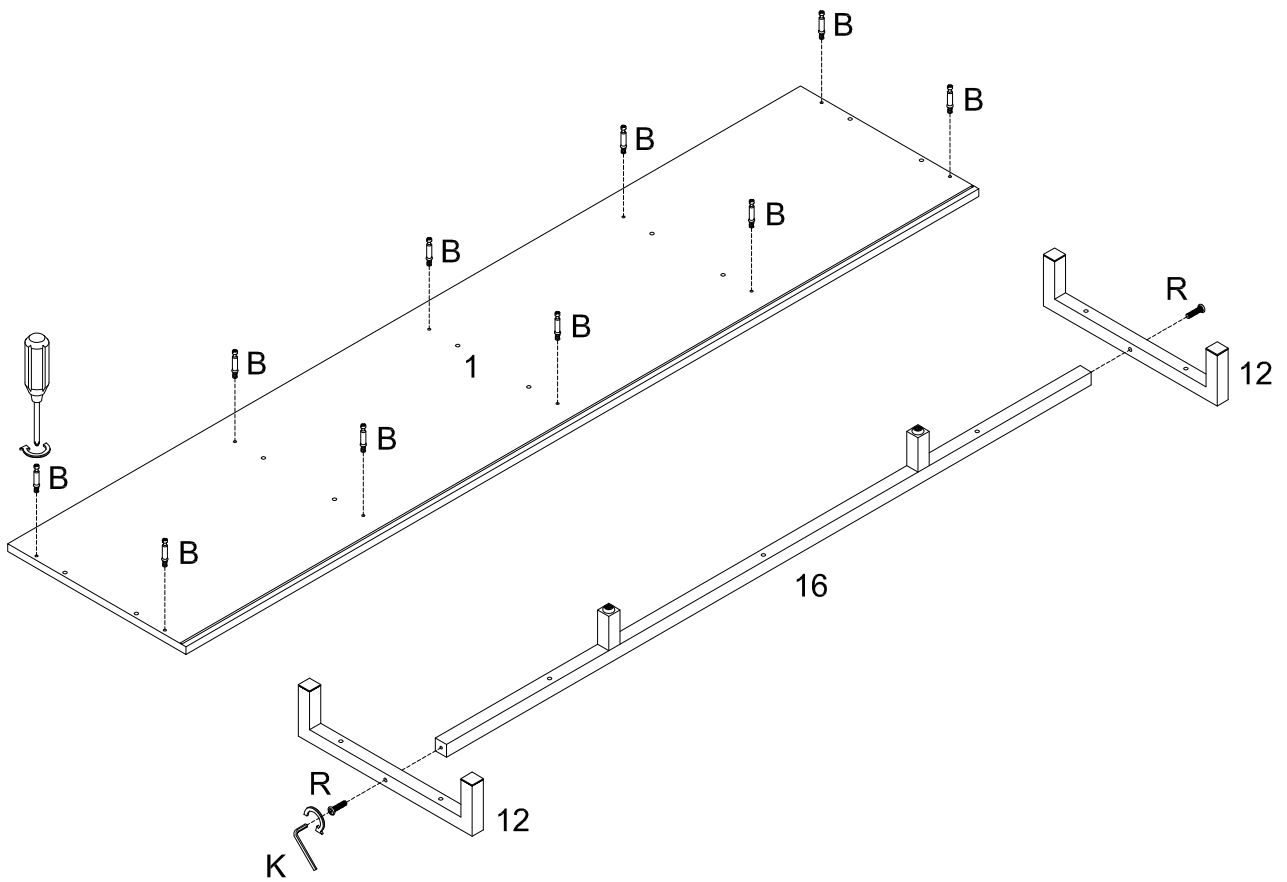

Secure cam bolt (B) into part (1) with Philips head screwdriver, and using bolt (R) secure part (12) to part (16) with hex key (K) as per diagram.

Step 2

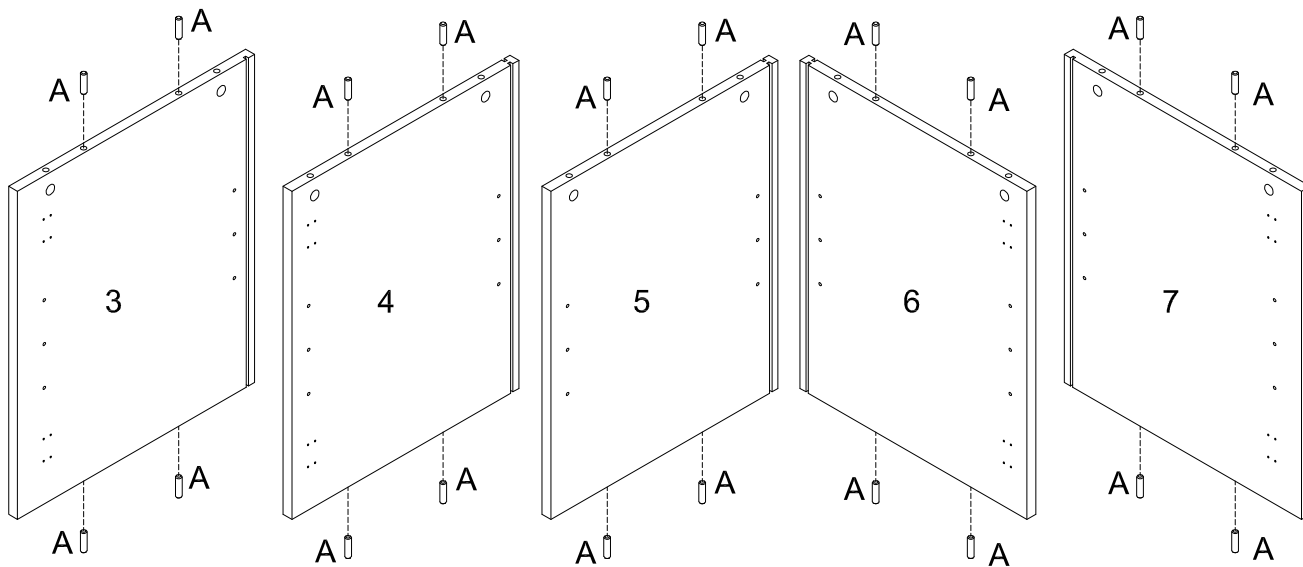

Insert wooden dowel (A) into parts (3,4,5,6,7) as per diagram.

Step 3

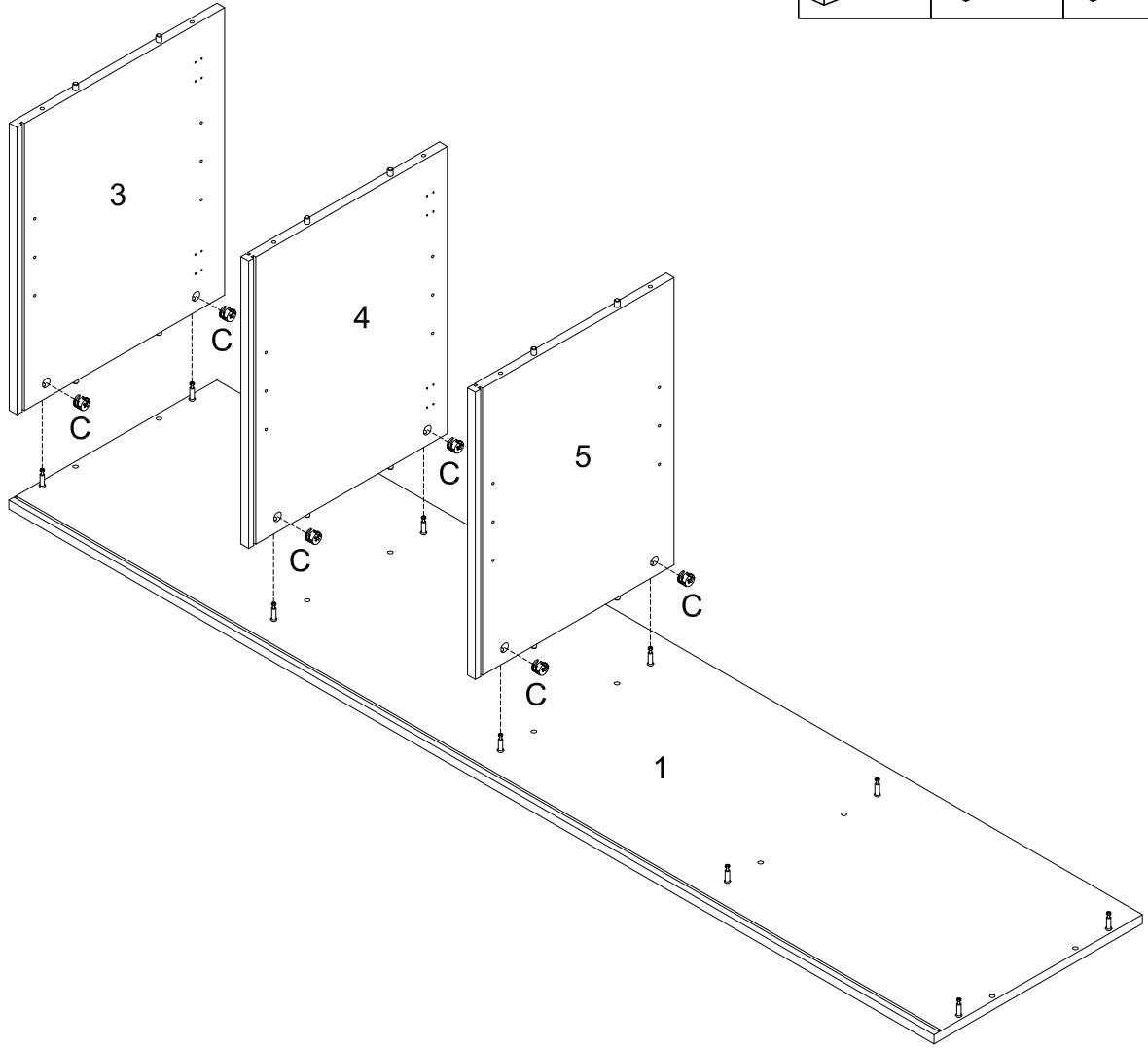
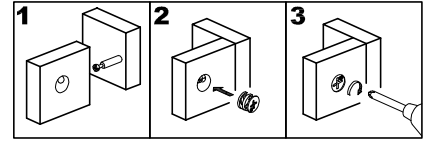

Using cam lock (C) secure parts (3,4,5) to part (1) with Philips head screwdriver as per diagram.

Step 4

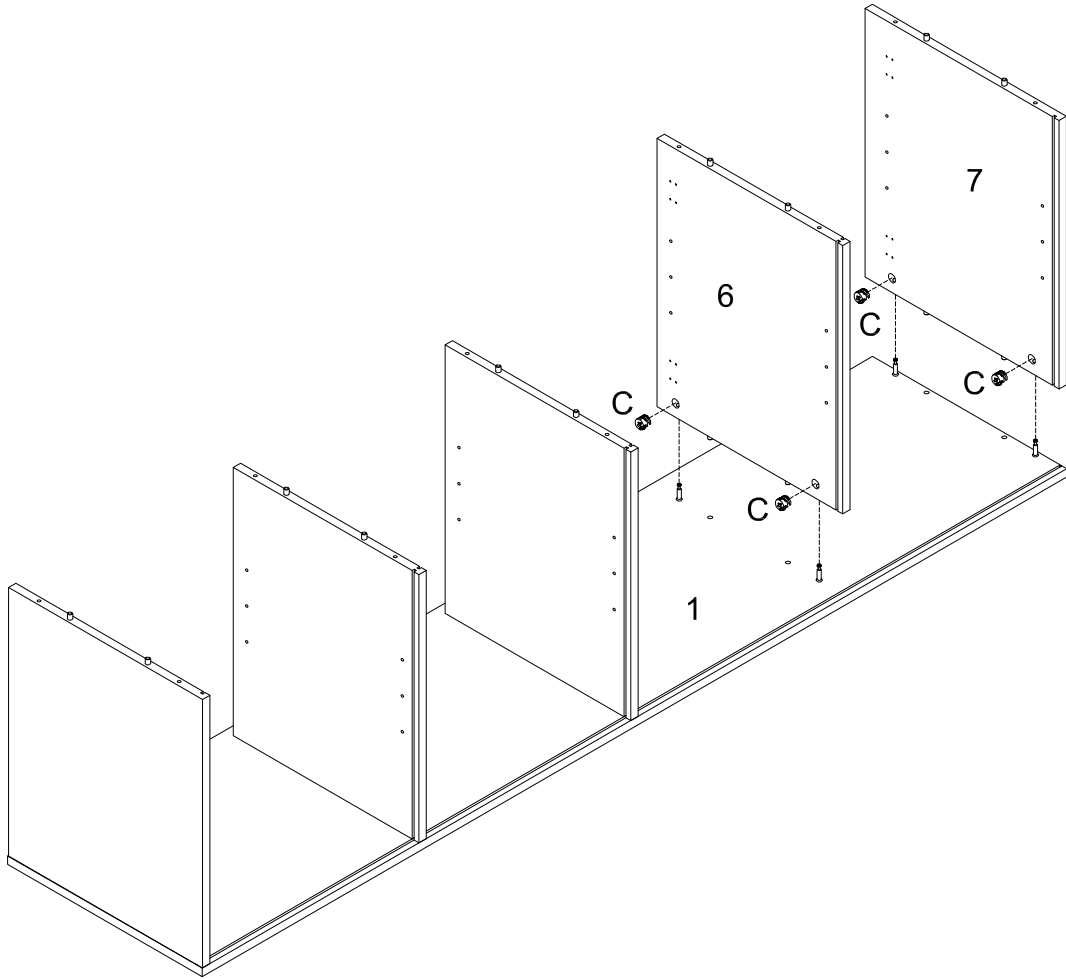
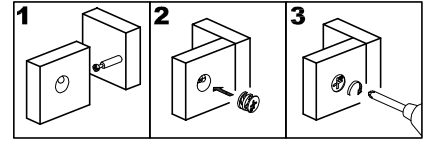

Using cam lock (C) secure parts (6,7) to part (1) with Philips head screwdriver as per diagram.

Step 5

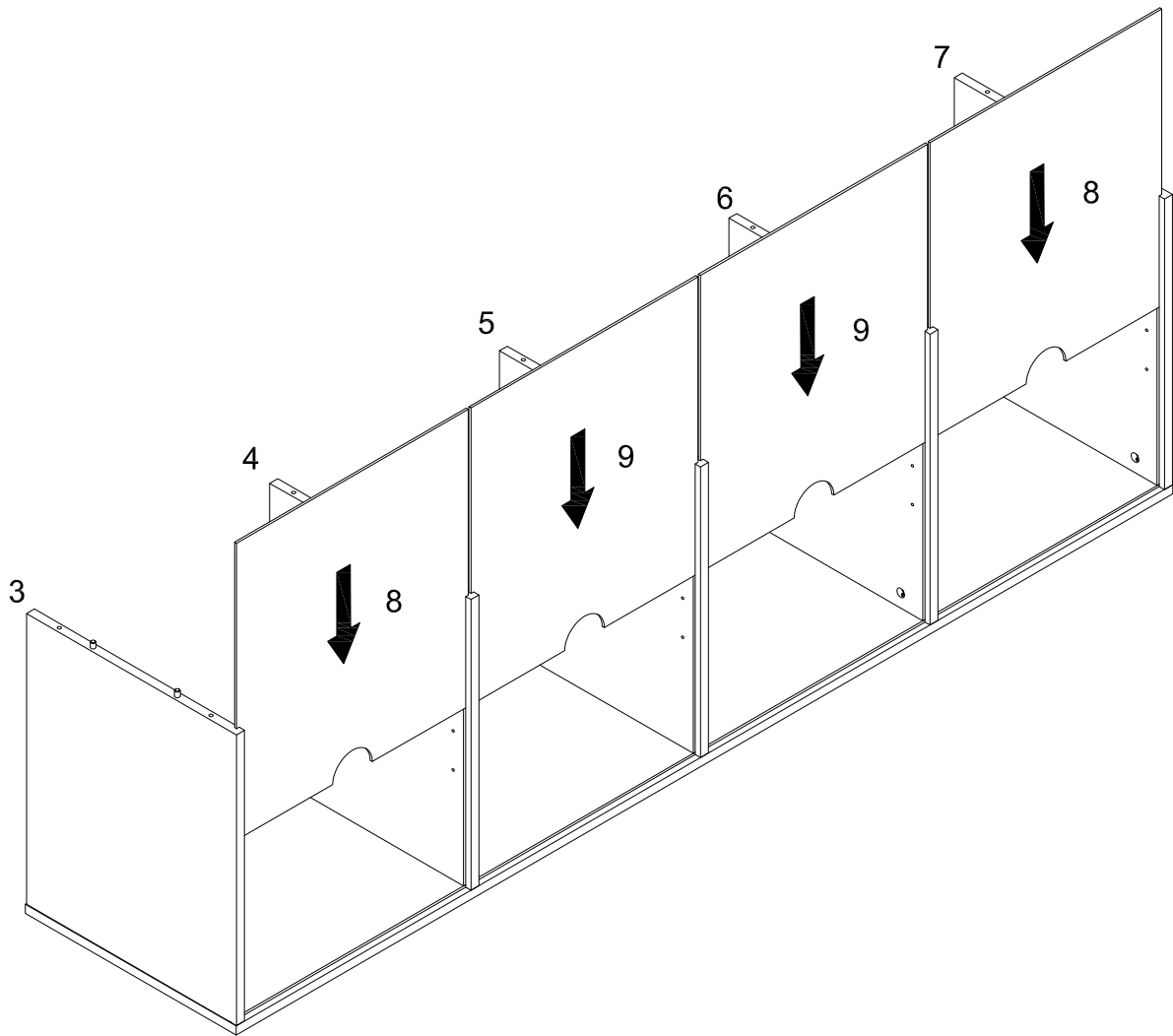

Put parts (8,9) as per diagram.

Step 6

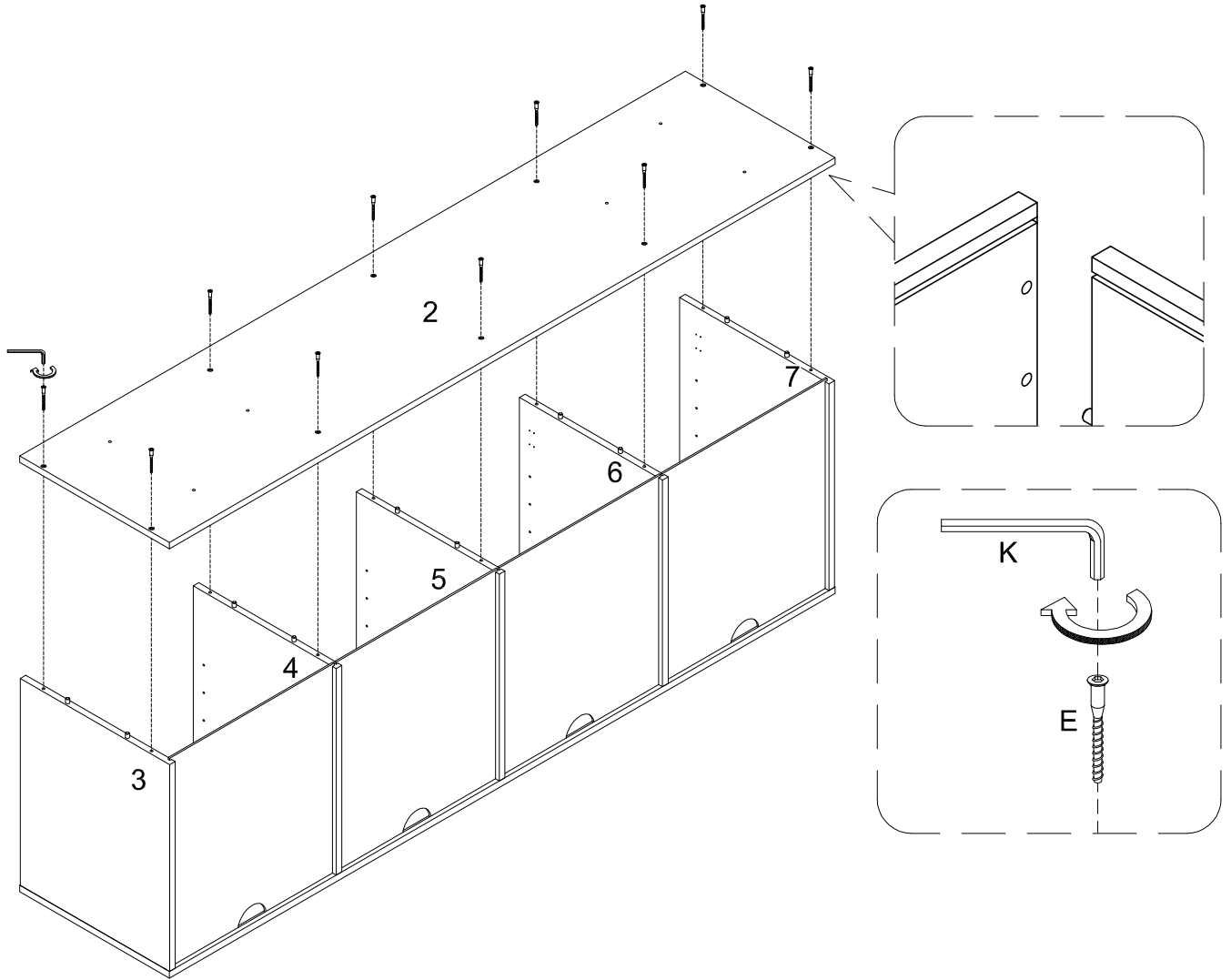

Using screw (E) secure part (2) to parts (3,4,5,6,7) with hex key (K) as per diagram.

Step 7

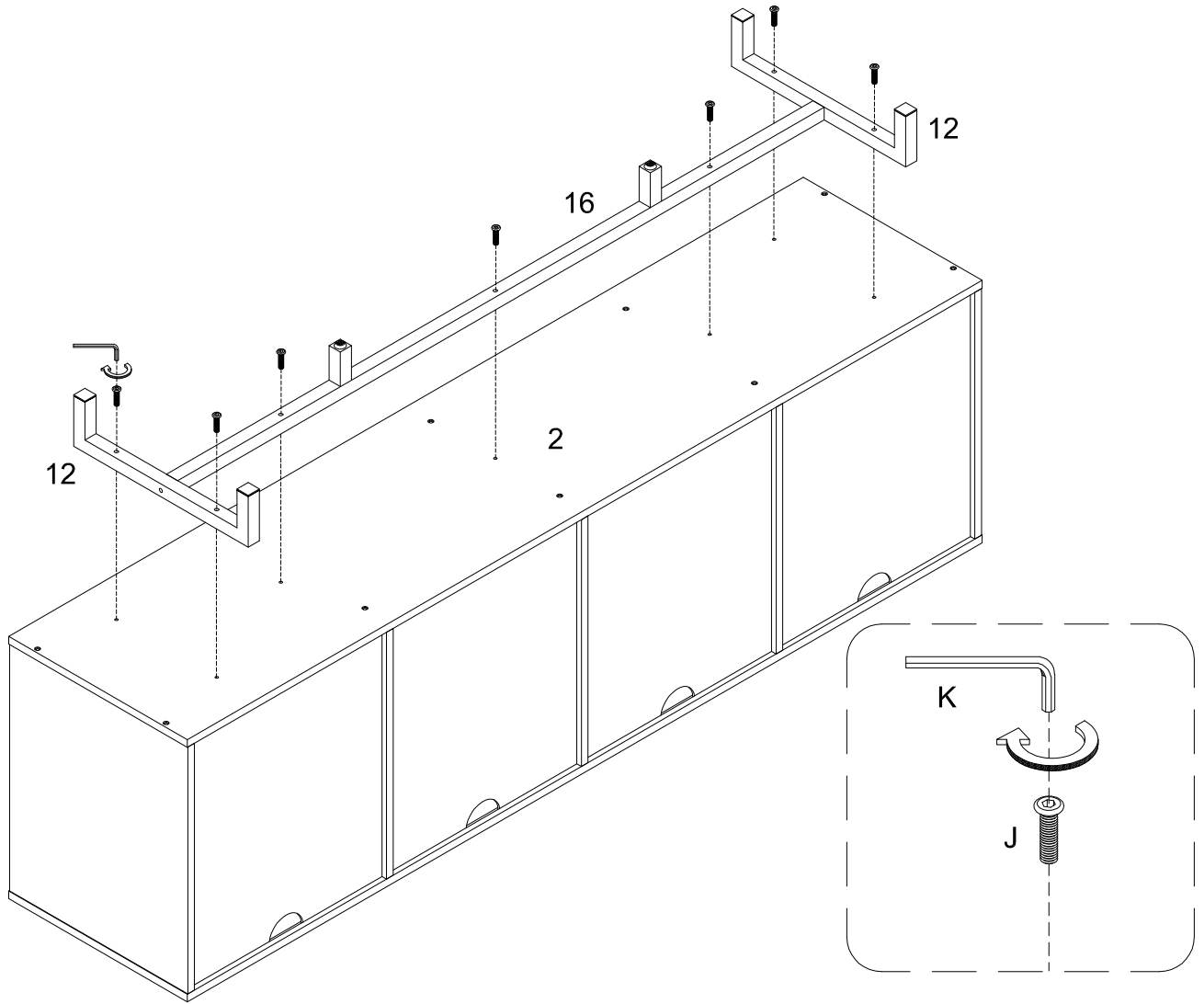

Using bolt (J) secure parts (12,16) to part (2) with hex key (K) as per diagram.

Step 8

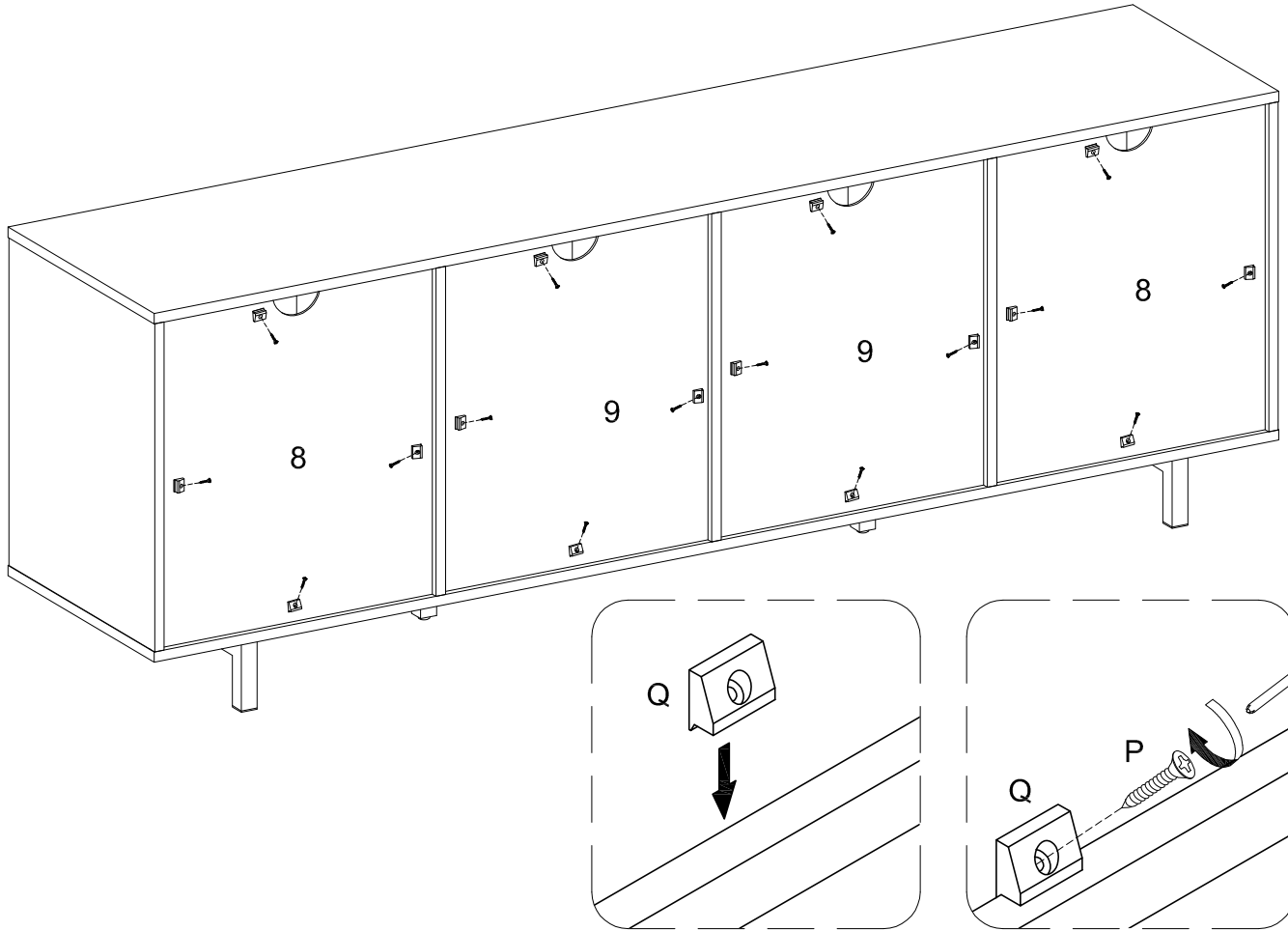

Using screw (P) attach plastic wedge (Q) to parts (8,9) with Philips head screwdriver as per diagram.

Step 9

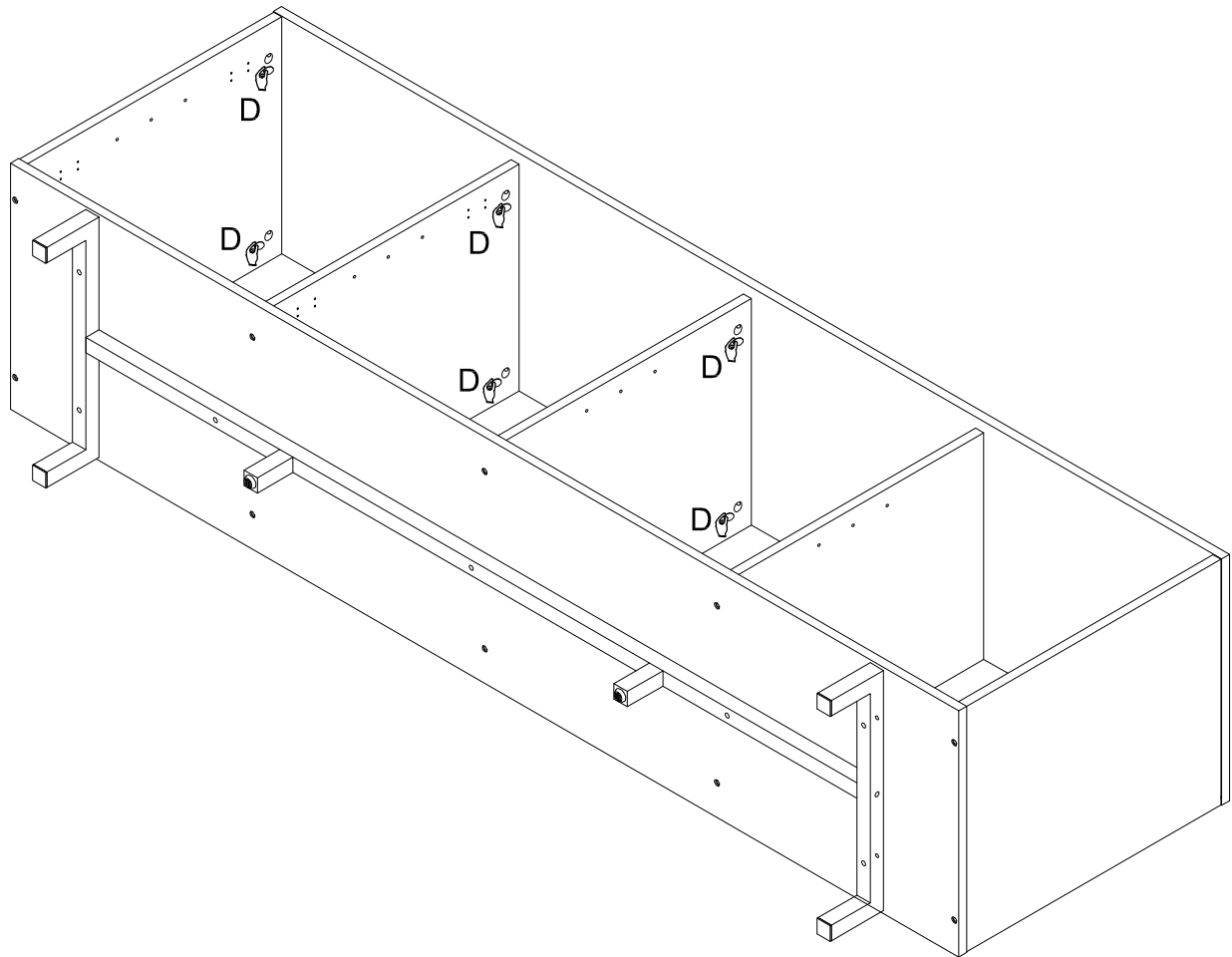

Place sticker (D) cover the holes as per diagram.

Step 10

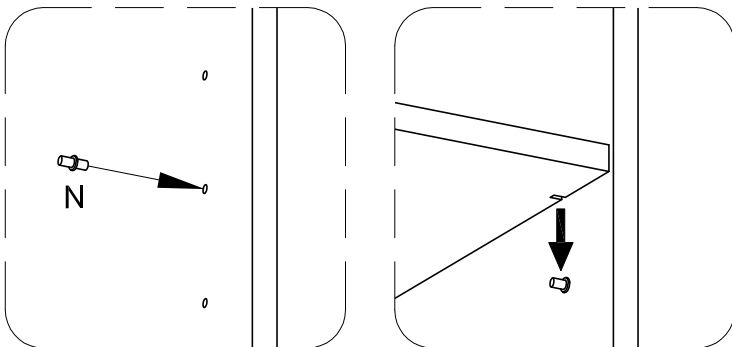
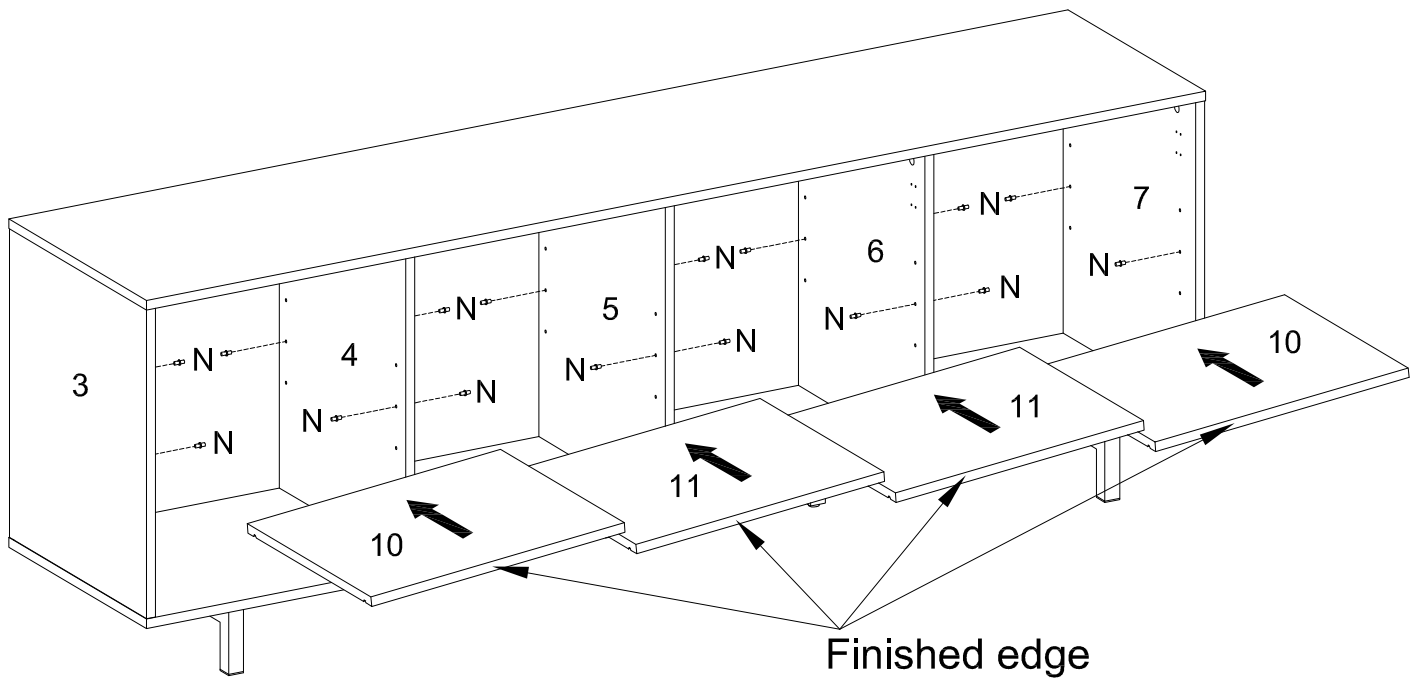

Insert shelf support pin (N) into parts (3,4,5,6,7), make sure you place shelf support pin (N) in the same level. So the shelf is not titled.

And then put parts (10,11) into unit as per diagram.

Tilt and rest the adjustable parts (10,11) onto the shelf support pin (N).

Step 11

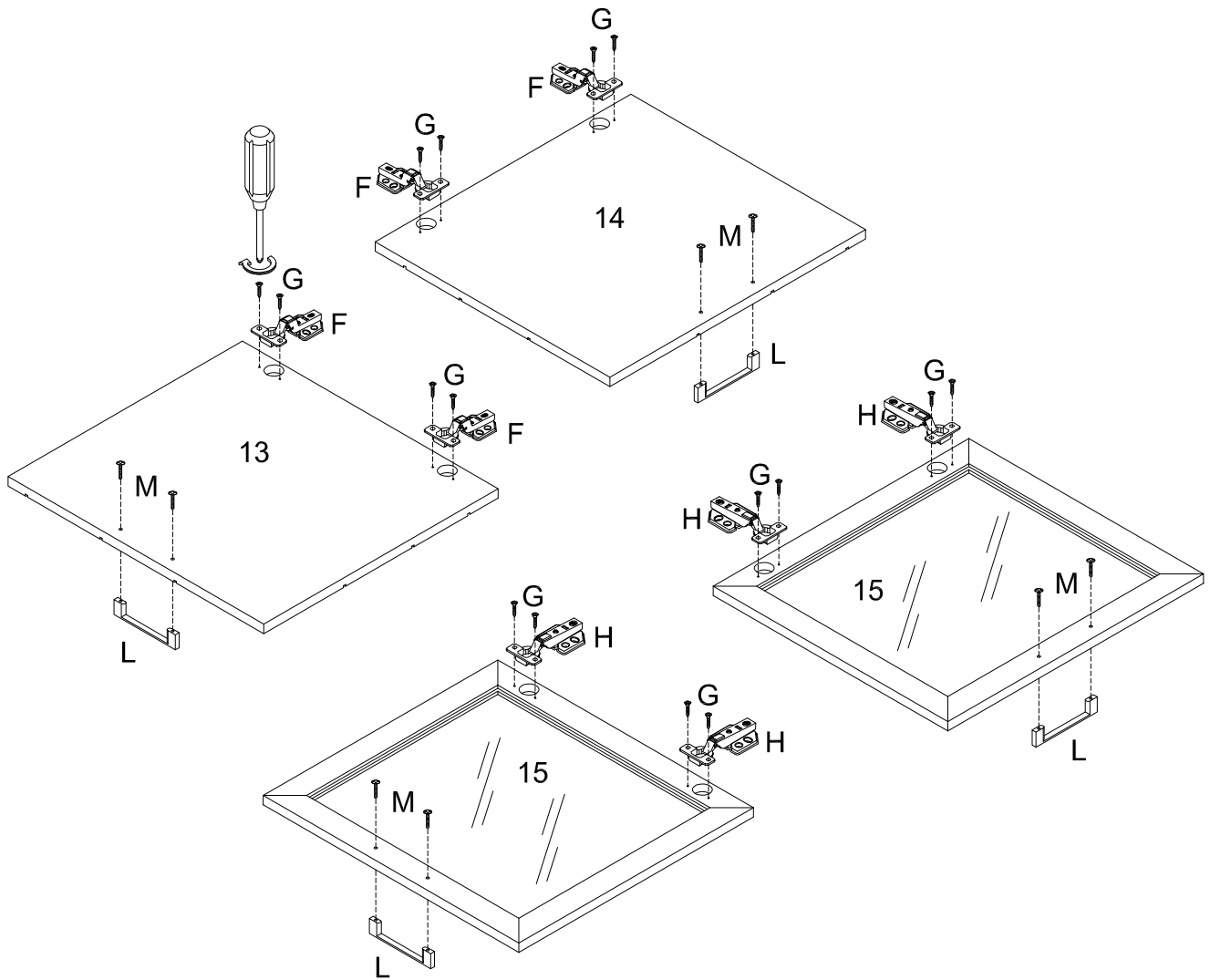

Using screw (G) attach Europe hinge (F) into parts (13,14), Europe hinge (H) into part (15), and using bolt (M) attach handle (L) to parts (13,14,15) with Philips head screwdriver as per diagram.

Step 12

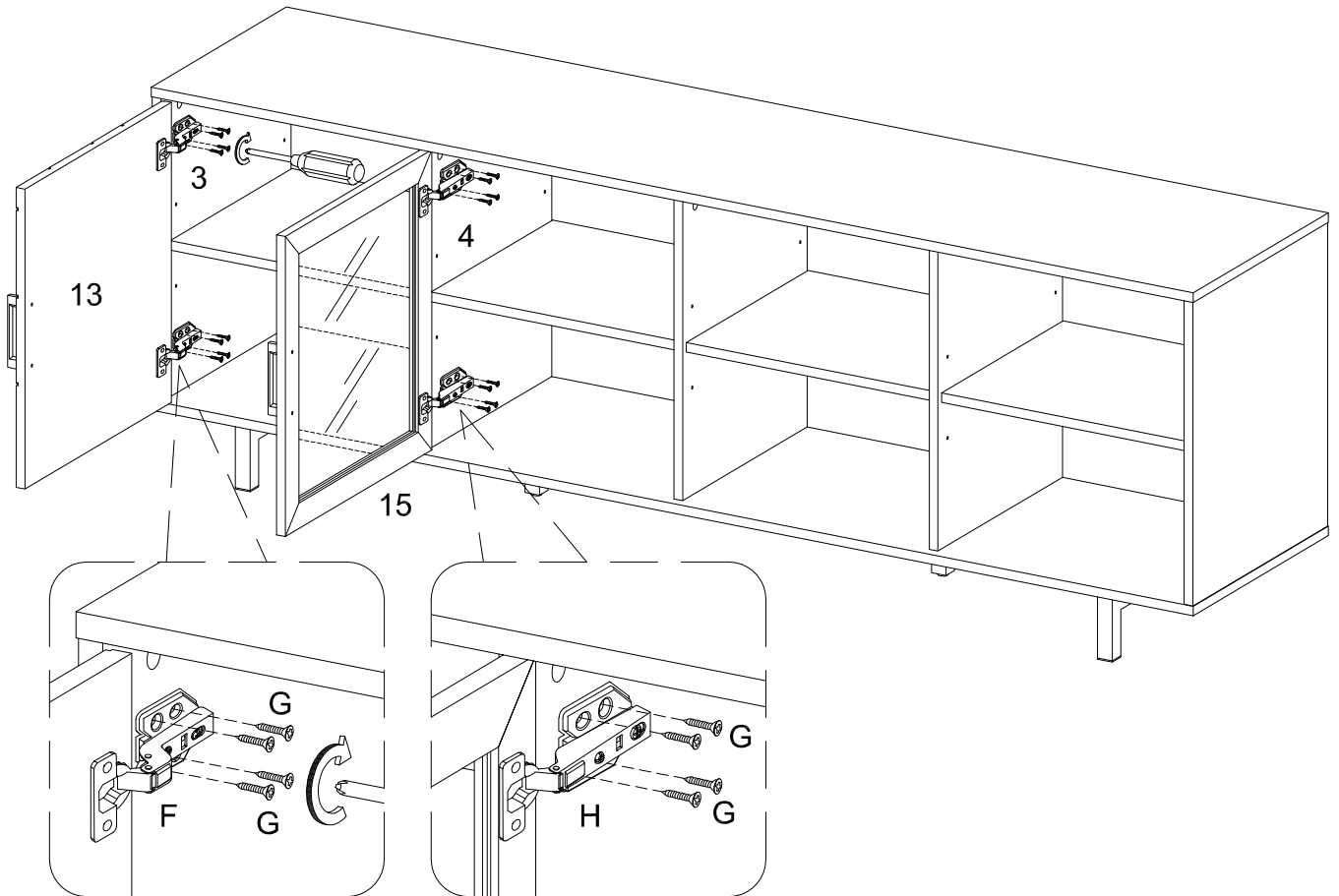

Using screw (G) attach Europe hinge (F) to part (3), and using screw (G) attach Europe hinge (H) to part (4) with Philips head screwdriver as per diagram.

Step 13

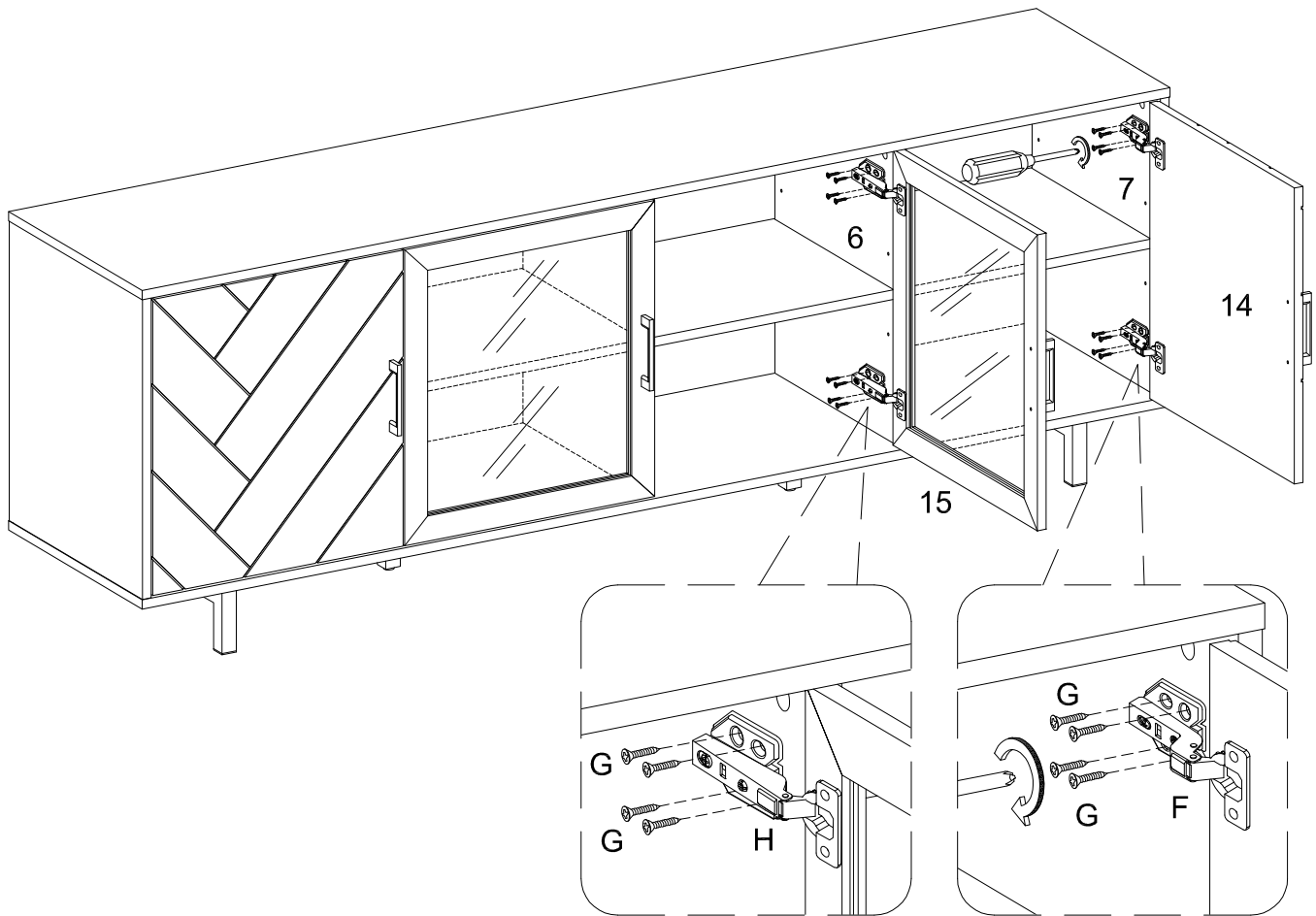

Using screw (G) attach Europe hinge (F) to part (7), and using screw (G) attach Europe hinge (H) to part (6) with Philips head screwdriver as per diagram.

Step 14

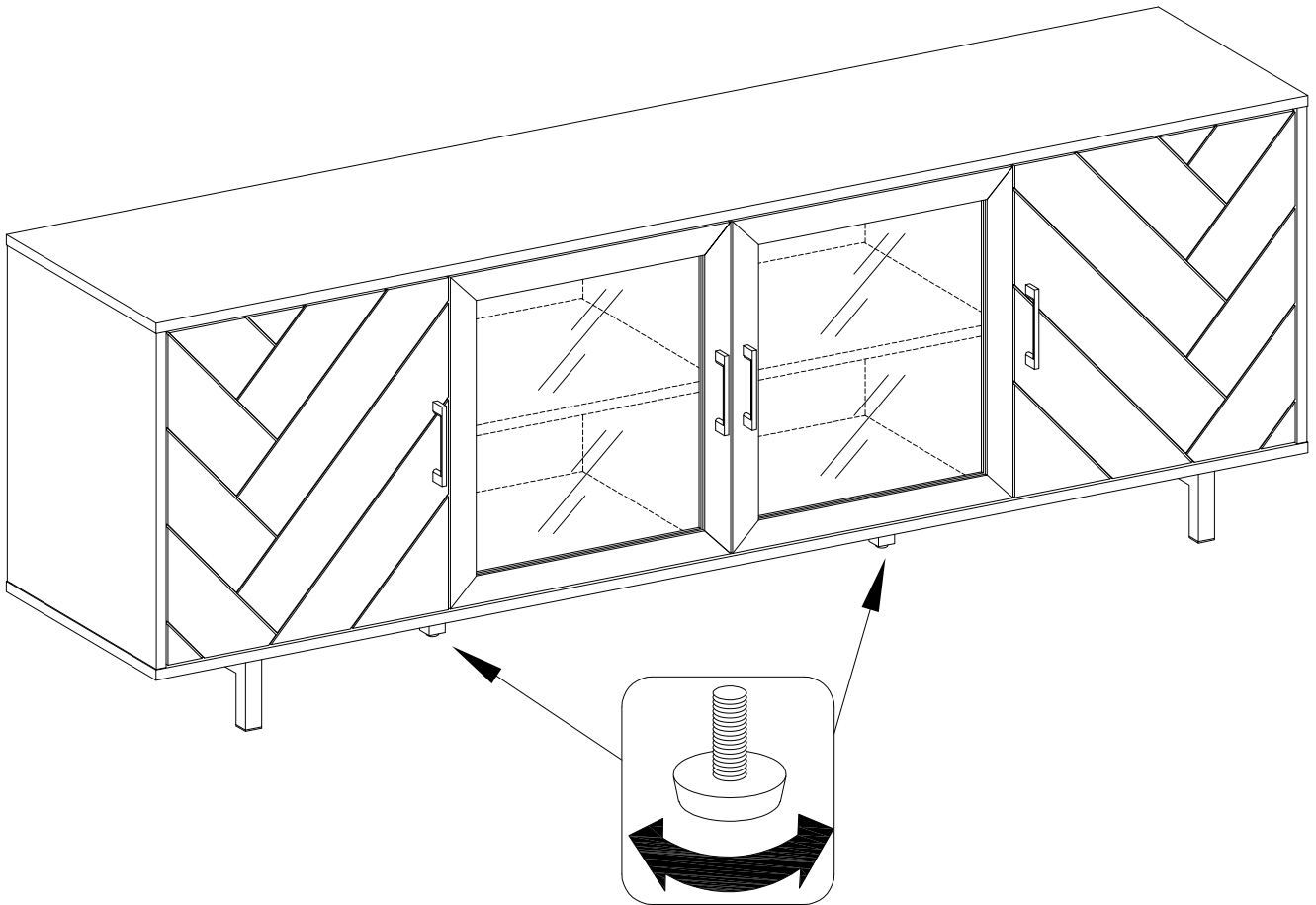

Position the assembled unit at the desired location, if necessary adjust the floor leveler at the bottom of the support leg to level the unit.

Step 15

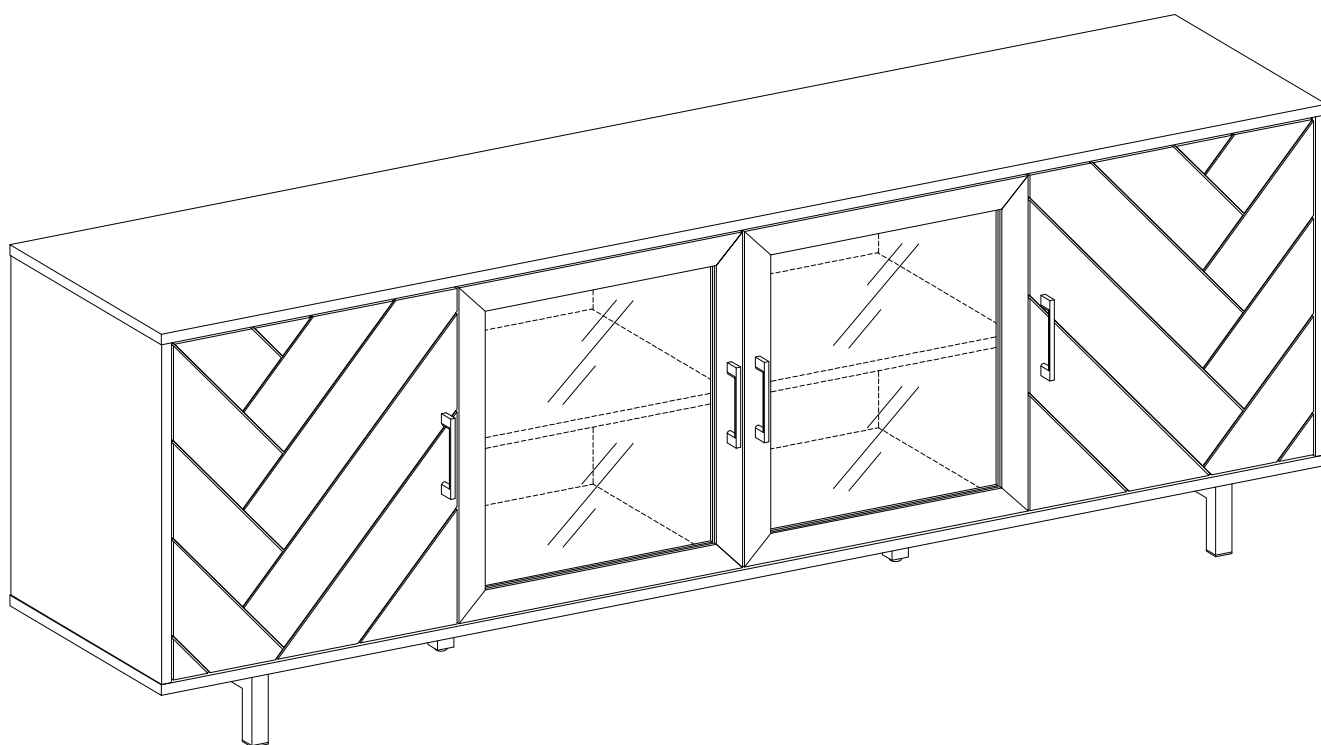

Final Assembly