

JAYLESSA WOOD 2 DRAWER DESK

DESIGN# SFV2217

Assembly Instructions

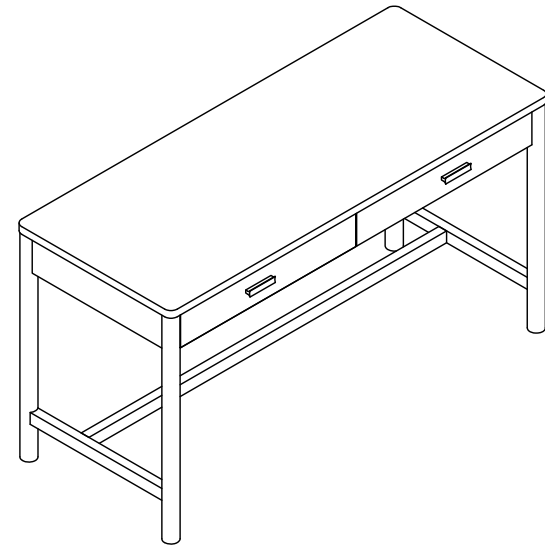

Need help?
Feel free to contact us via email or call
if you have any specific questions!









contact us:
cs@safavieh.com
866-422-9070

SAFAVIEH
C O U T U R E





Thanks for bringing Safavieh Couture into your home

Everything we make is incredibly simple to set up, including your new desk. You won't need any additional tools.

Parts List

- A X 1 
- B X 1 
- Front Right Leg
- C X 1 
- Back Right Leg
- D X 1 
- Front Left Leg
- E X 1 
- Back Left Leg
- F X 1 
- Right Stretcher
- G X 1 
- Left Stretcher
- H X 1 
- Longer Stretcher

Hardware List

- HW1 x 6 
- Hex Socket Bolt $\frac{5}{16}$ "-18 x 2- $\frac{1}{2}$ "
- HW2 x 6 
- Hex Socket Bolt $\frac{1}{4}$ "-20 x 1- $\frac{1}{4}$ "
- HW3 x 6 
- Dowels $\frac{5}{16}$ " x 1- $\frac{1}{8}$ "
- HW4 x 1 
- Allen Key $\frac{5}{32}$ "
- HW5 x 2 
- Anti-Tip Hardware

1

Insert 2 Dowels (HW3) into both ends of the Longer Stretcher (H). Attach it to the Right Stretcher (F) and the Left Stretcher (G) by using the Allen Key (HW4) to screw in 2 Hex Socket bolts (HW2) as shown below.

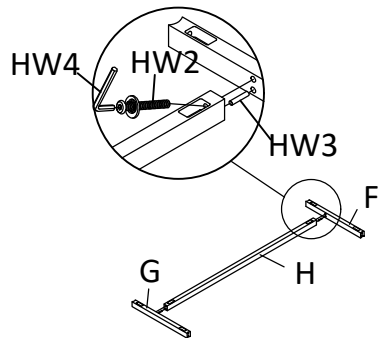

2

Insert Dowels (HW3) into both ends of the Right Stretcher (F) and the Left Stretcher (G). Attach the Right Stretcher (F) to the Front Right Leg (B) and Back Right Leg (C) and attach the Left Stretcher (G) to the Front Left Leg (D) and Back Left Leg (E) by using the Allen Key (HW4) to screw in the Hex Socket bolts (HW2) as shown below.

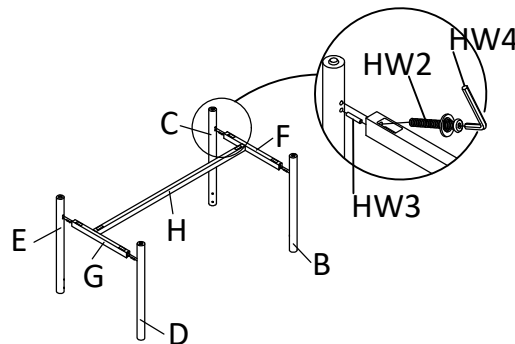

3

Place the Desktop (A) upside down on a soft surface. Align the screw holes on the Desktop (A) with those on the top of the assembled base. Use the Allen Key (HW4) to screw in 4 of the Hex Socket bolts (HW1) to attach the Back legs (C & E) to the desktop (A). Then use the Allen Key (HW4) to screw in 2 of the Hex Socket bolts (HW1) to attach the Front legs (B & D) to the desktop (A) as shown below.

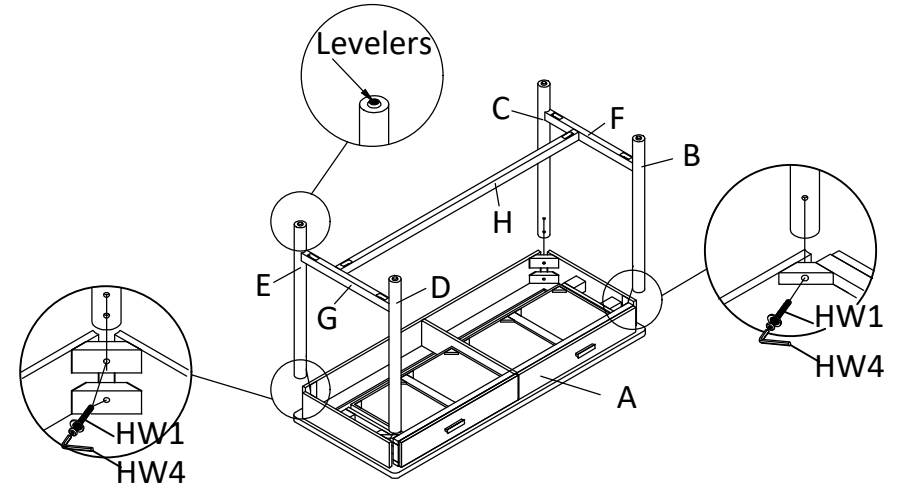

4

Turn the Desk upright. Place the Desk in the place where you will use it. Follow the installation instructions of the Anti-Tip Hardware (HW5) to attach the product to the wall. Adjust the levelers on the bottom of the legs as needed to make the desk level. We'd love to see it - just tag us (we're @safavieh) and use the hashtag #safavieh on Instagram!

