

Assembly Instructions / Instrucciones De Montaje

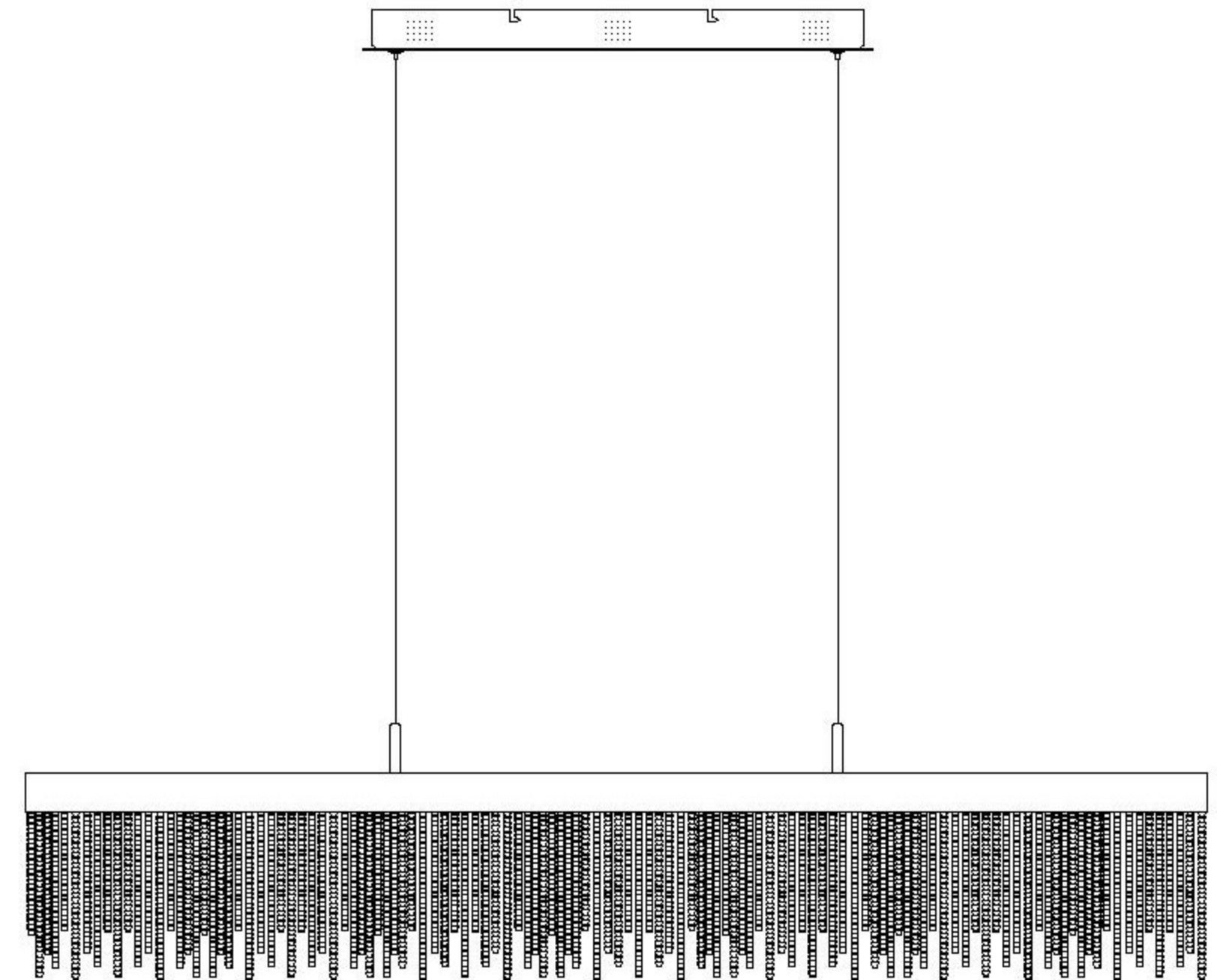
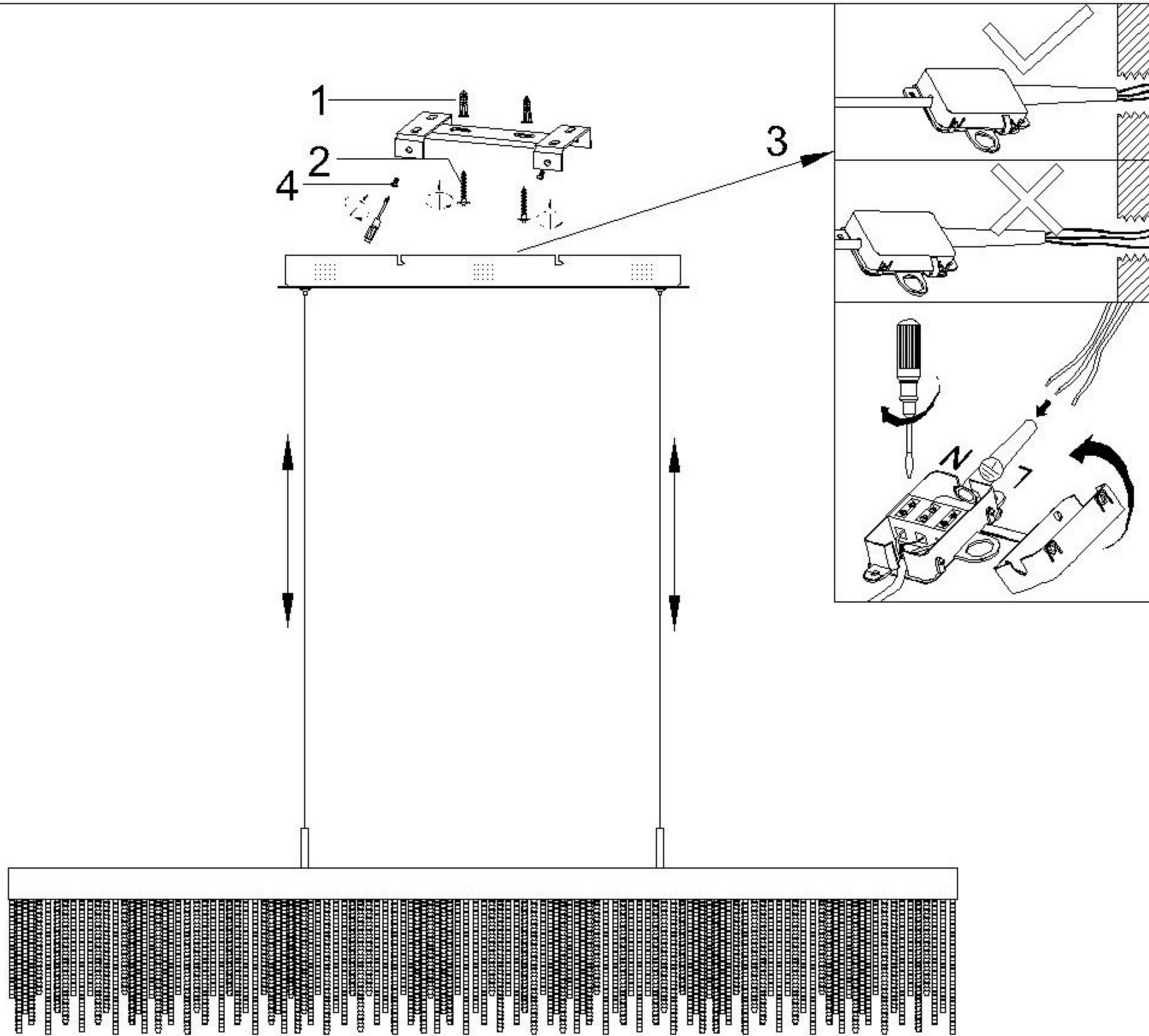

LED 33W / INCL.
110-250V~ 50/60Hz

NOTE:

- 1.This lighting is only for indoor use.
- 2.Do not switch on before assembling.

NOTA:

- 1.Esta lámpara solo podrá utilizarse en interior.
- 2.No enchufe la lámpara antes de montarla.

REF.: 6250

m  ntra