

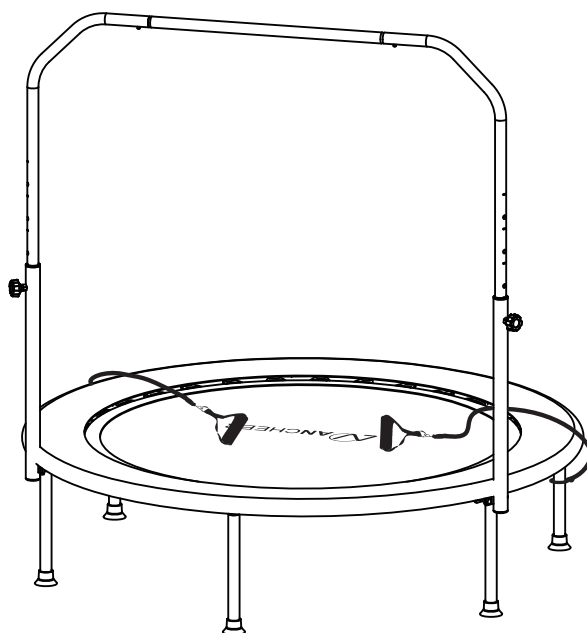

USER MANUAL

48" fitness trampoline



WARNING

·Read all precautions and instructions in this manual before using this equipment.



WARNING
CHOKING HAZARD
small parts
Adult assembly required





Anything damaged or lost when received it, please contact us for replacement.
Greatly appreciated for sharing your experience online, wish you a fit life.

CONTENTS

WARNING	1
PARTS LIST	2
ASSEMBLY INSTRUCTIONS	4
SAFETY TIPS	12
WARRANTY INFORMATION	16

Customer After-Sales Service

-  Phone Number: 626 688 9296
 -  Mailbox: suppporthappy@gmail.com
 -  Working Time: Monday - Friday
 - 10:00-12:00 AM PST
 - 2:00-5:00 PM PST
-

To reduce the risk of injury, read and follow all of the warnings, precautions, and instructions in this manual before you use the trampoline. Warnings and instructions for care, maintenance, and use of this trampoline are included to promote safe enjoyable use of this equipment.



WARNING



- Misuse and abuse of the trampoline is dangerous and can cause serious injury. Read and follow the manual and all warnings before use.
- WARNING. Only for domestic use.
- WARNING. CHOKING HAZARD! - Small parts. Not for Children under 3 years old.
- Protect children: Prevent falls and suffocation
- WARNING. Only one user at a time. Collision hazard.
- WARNING. DO NOT attempt or allow somersaults. Landing on the head or neck can cause serious injury, paralysis, or death, even when landing in the middle of the bed.
- WARNING. Do not allow more than one person on the trampoline. Use by more than one person at the same time can result in serious injury.
- WARNING. Use trampoline only with mature, knowledgeable supervision.
- WARNING. Empty your pockets and hands before jumping.
- If parts are missing or damaged, please contact After-sales mailbox.
- Please observe the warning signs in the manual for proper use and maintenance of the trampoline. If the manual is not followed, we are not responsible for any injuries that may occur while using the trampoline.

■ Note

Before assembly, compare all the parts with the parts list. Any parts missing or damaged, do not attempt to assemble, and please contact customer service for replacement.

Part list

Before assembling, please refer to the diagram below to identify the parts used in the assembly and check that all components are included.

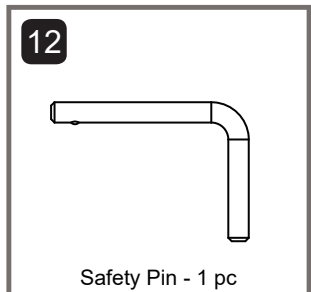
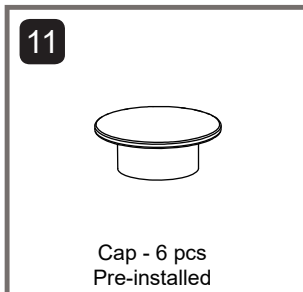
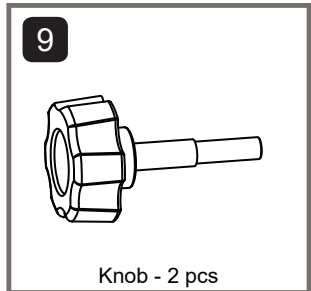
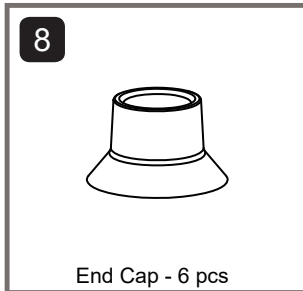
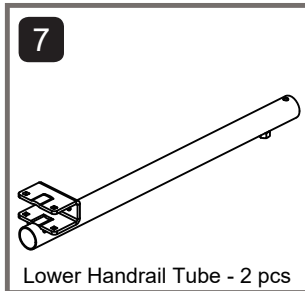
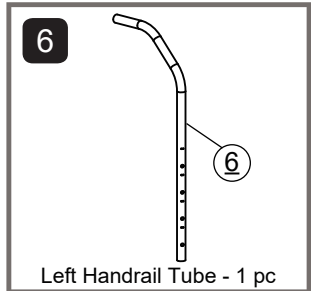
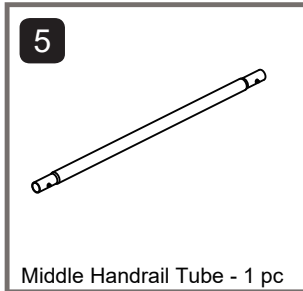
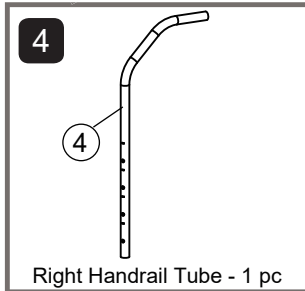
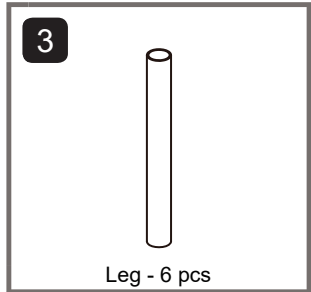
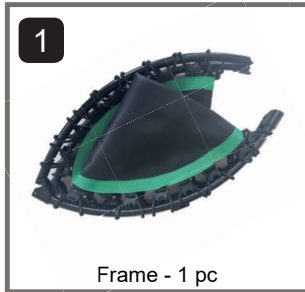

Part list

Before assembling, please refer to the diagram below to identify the parts used in the assembly and check that all components are included.

13



M6x13mm Bolt - 4 pcs

14

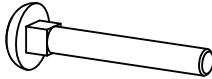

M6x42mm Bolt - 4 pcs

15



M6 Washer - 8 pcs

16



M6 Nut - 4 pcs

17



Elastic Rope - 2 pcs
(2 spare parts)

18

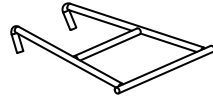

Tool - 1 pc

19

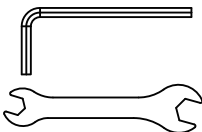

Wrench - 1 set

20



Big Washer - 2 pcs

Assembly Instructions

1

Two adults open the trampoline as shown.

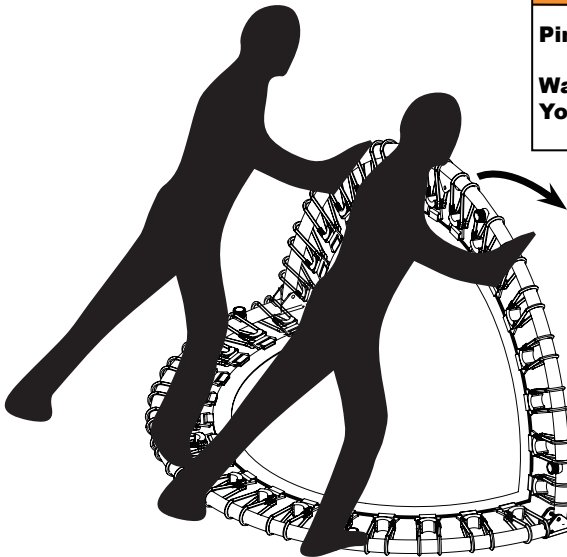
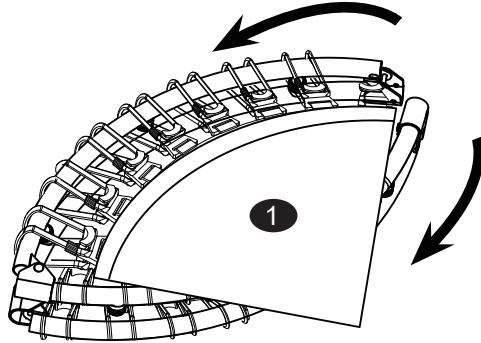

 WARNING	
Pinch Point	
Watch Your Hands	

Assembly Instructions

2

Attach the Safety Pin (12) as shown.

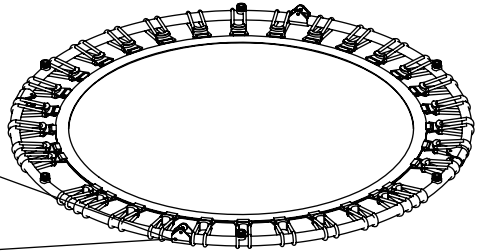

Make sure the safety pin (12) is always connected to prevent the danger of the trampoline folding during the jump.



When the rope is damaged, you can replace it with a new one according to the pictures below.

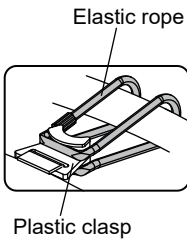
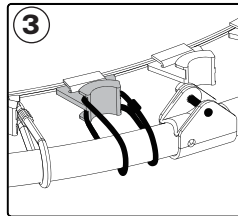
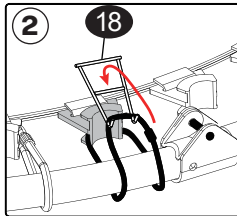
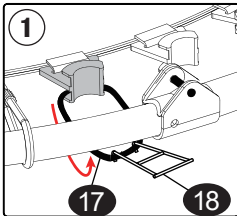

Check the trampoline to make sure all the Elastic ropes are stuck in the Plastic clasp.



Note
Adjust the elastic ropes to make sure they are straight up against the frame and not tilted.

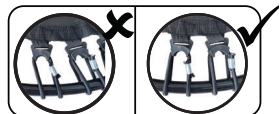

Assembly Instructions

3

Remove the cap (11).

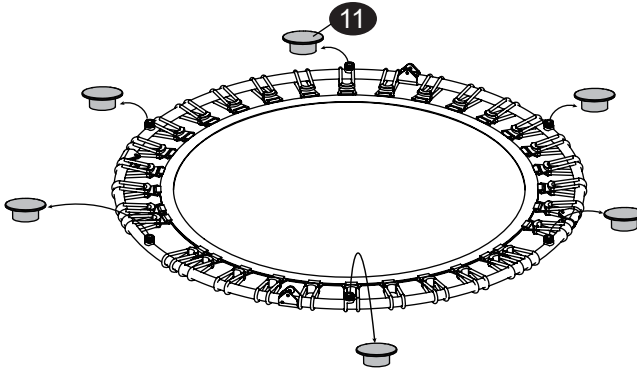

Stand the frame up. Find out the holes in the frame as shown below. Open the Pad (2), find two large holes, and match the large holes with the holes in the frame.

Then place the Pad over the frame as shown.

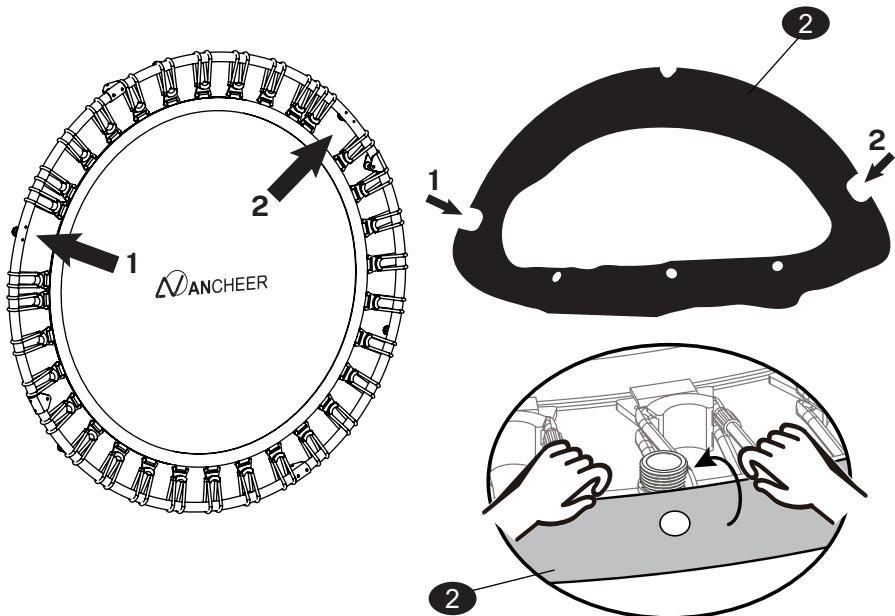

Assembly Instructions

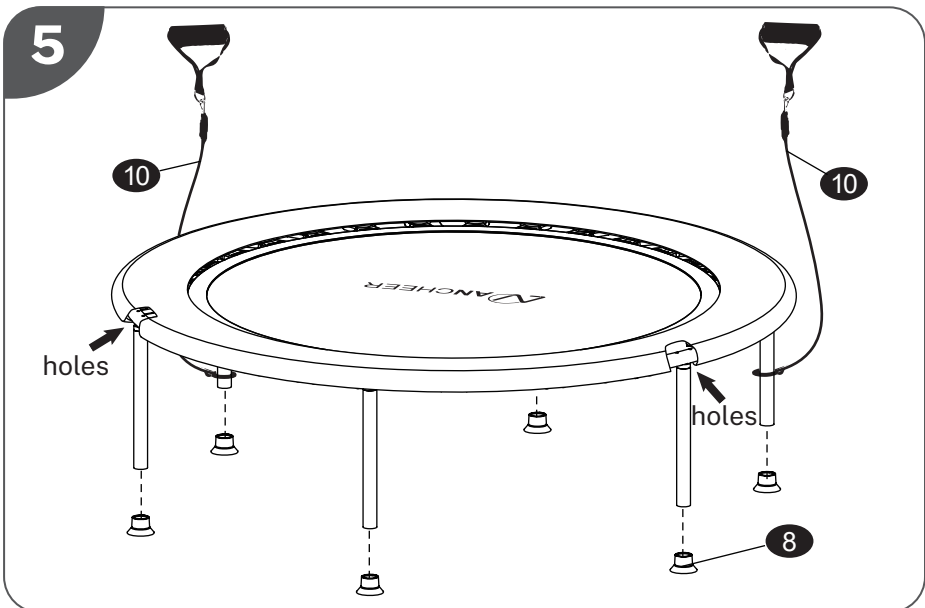
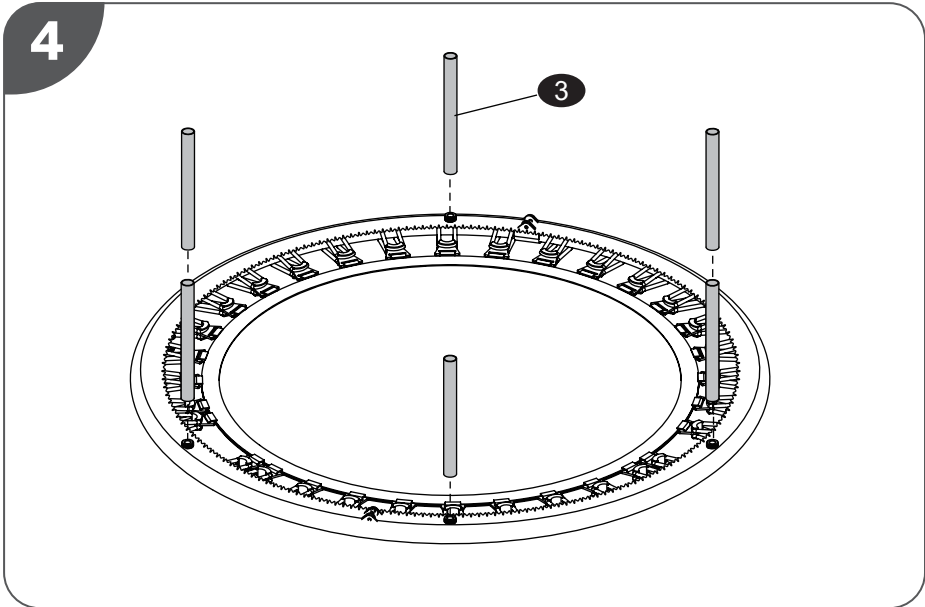

Assembly Instructions

6

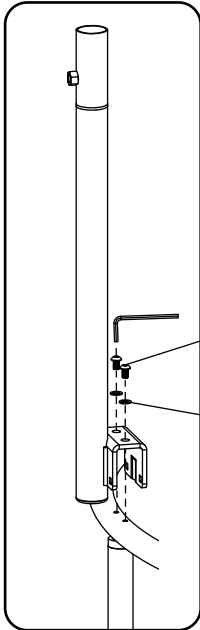

13

15

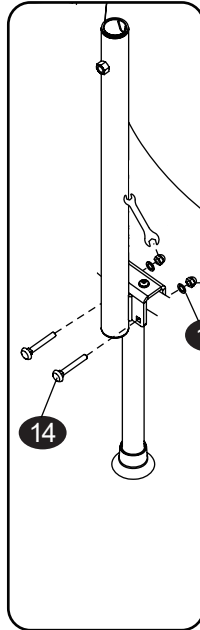

14

16

15



13 M6x13mm Bolt - 4 pcs



14 M6x42mm Bolt - 4 pcs



15 M6 Washer - 8 pcs



16 M6 Nut - 4 pcs

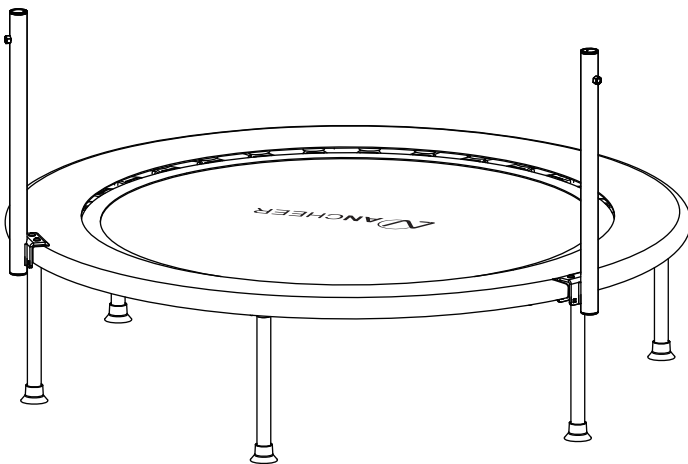

Assembly Instructions

7



The dent here is for height adjustment, but not defective.

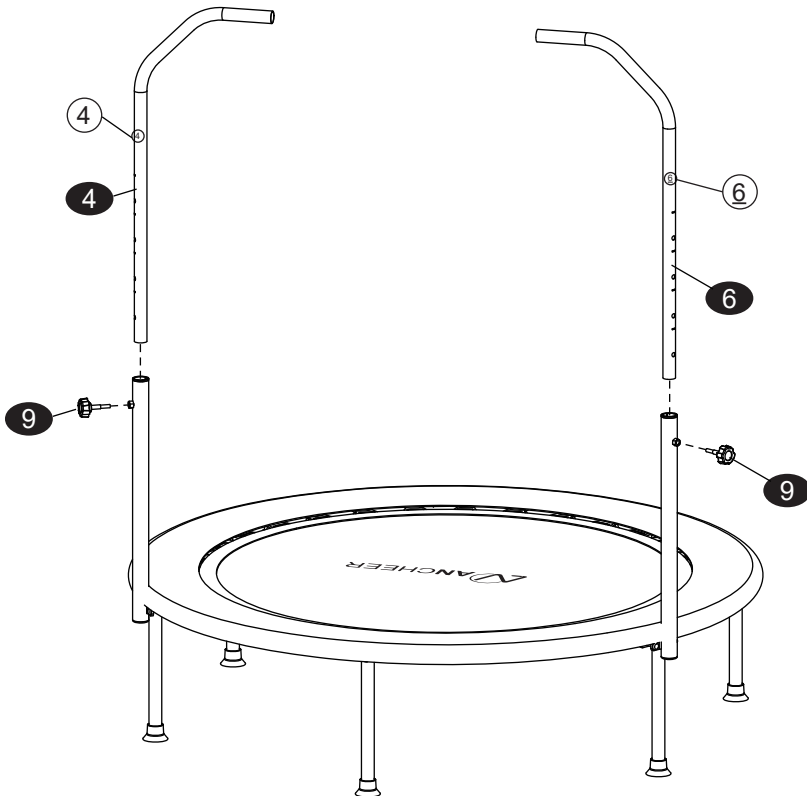
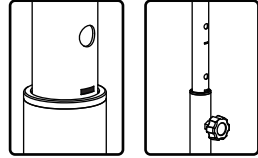

Assembly Instructions

8

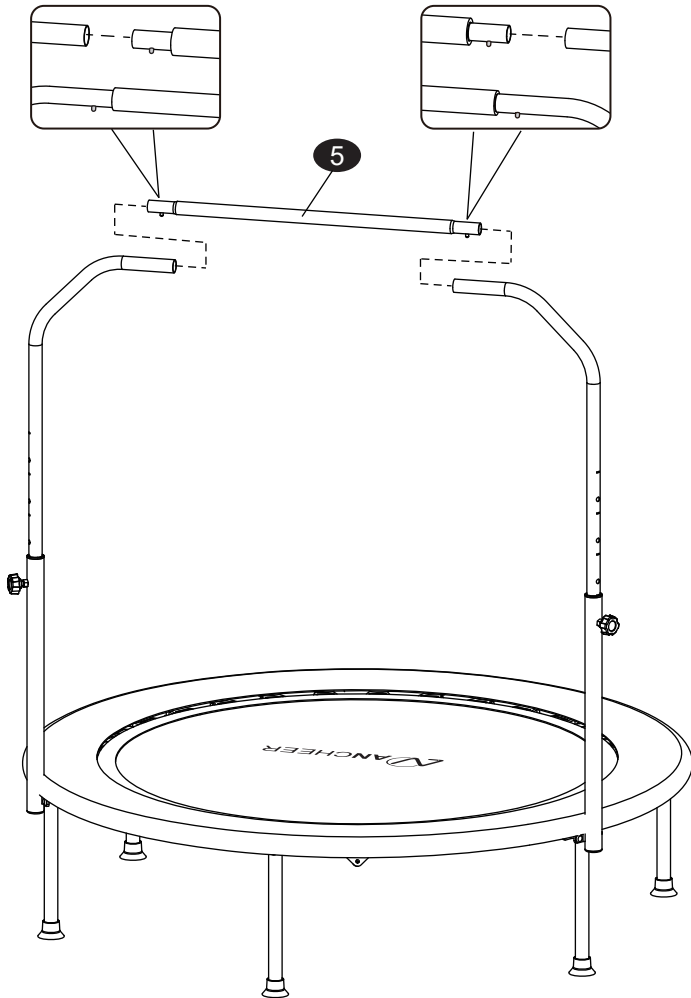

Assembly Instructions

9

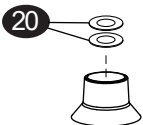
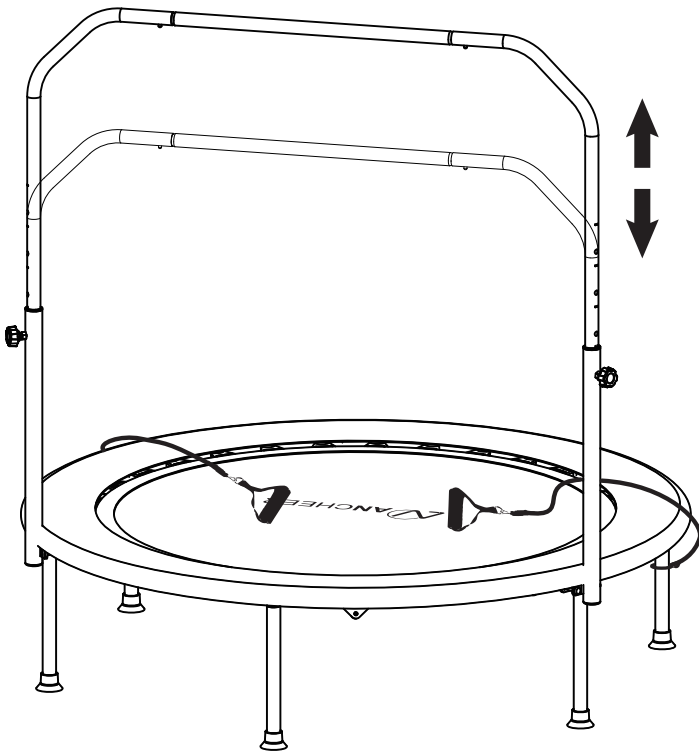

*Some floors may not be 100% leveled. Maybe one leg can't touch the ground. Added Big Washers (20) are for stabilizing the leg. Add 1 or 2 pieces to get leveled. Use at your discretion.

Safety Tips

Read all warnings on the product. Before using, read all the precautions and instructions in this manual. Keep this manual for future reference. All use of the trampoline is under your responsibility.

Electrocution Hazard

No lights, electric heaters, extension cords, or household electrical appliances are to be permitted on the trampoline.

Hazards Associated with Animals, Sharp or Breakable Objects

To avoid damage to the trampoline, do not allow pets or other animals inside of the trampoline. The claws and teeth of animals can damage the mat. Do not jump on the trampoline while holding or wearing a sharp or breakable object.

Presentation

The trampoline is a fun activity that allows you to maintain your shape and your tonicity.

A. General principles of use of your trampoline

1. Only use this product in the manner described in this manual. Keep this manual for the entire life of the product.
2. Trampolines over 20 in. (51 cm) tall are not recommended for children under 6 years of age.
3. The owners are responsible for making sure that all the users of the product are suitably informed of all the precautions for use.
4. Our company cannot be held liable for claims of injury or damage sustained by any person or property originating from the use or misuse of this product by the purchaser or by any other person.
5. This product is intended for domestic use only. Do not use the product in any commercial, rental or institutional setting. Use this product indoors, keep your trampoline out of sunlight, protected from moisture and dust, on a flat, solid surface and in a sufficiently wide space. Ensure that there

-
- is sufficient space for safe access to the product and around the product. To protect the floor, cover the floor with a carpet under the product.
6. It is the user's responsibility to ensure proper maintenance of the unit. After assembling the product and before each use, check that the fasteners are tight and do not protrude. Check the condition of the parts most subject to wear (such as elastics and rebound fabric).
 7. Reach out to Customer Care if your product is damaged. Immediately replace any worn or defective parts and do not use the product before complete repair.
 8. Do not store the product in a humid place (pool edge, bathroom...).
 9. To protect your feet while exercising, wear sports shoes. DO NOT wear loose clothing that could become caught in the machine. Take off jewellery.
 10. Tie long hair back so that it does not get in the way when exercising.
 11. If you feel any pain or if you become dizzy while exercising, stop immediately, rest, and consult your doctor.
 12. Before undertaking this exercise program, it is necessary to consult a physician to ensure that there are no contraindications, especially if you have not been sporting for several years.
 13. Do not modify your product. Inspect the trampoline before each use. Make sure the frame padding is correctly and securely positioned. Replace any worn, defective, or missing parts.

B. Place of use of your trampoline

14. The product must be placed on a flat, stable and rigid surface. Place the trampoline on a level surface before use.
15. Check that there is no ceiling above your practice area.
16. Check that there are no annoying elements above your trampoline (branches, cables...)
17. Adequate overhead clearance is essential. A minimum of 24 ft. from ground level is recommended. Provide clearance for wires, tree limbs, and other possible hazards.
18. Check that there are no pointed or sharp objects near your trampoline.
19. Check that your area of use is well lit.
20. Secure your trampoline against any misuse.
21. Check that there is no obstructing element under the rebound canvas.
22. Every person in charge of monitoring the use of the trampoline must be an adult, know the conditions of use.

C. Use your trampoline

23. Do not make acrobatic figures. Any landing on the head or neck is very dangerous and can result in serious injury or death.
24. No more than one person at a time on the trampoline (avoid shocks).
25. An adult who is familiar with this leaflet should monitor the use of the trampoline.
26. The handlebar (if equipped) is a help to balance. Do not put all the weight of your body on the handlebar.
27. Do not jump on the trampoline to climb on it.
28. Do not jump with rebound or without rebound from the trampoline to get off. Sit on the edge and place your feet on the floor.
29. Do not use your trampoline as an impulse to catch an object or jump out of it.
30. You must know how to stop a jump session before mastering any other action: To stop, bend your knees as your feet come into contact with the trampoline.
31. Before you start practicing, you must learn the fundamentals of jumping.
32. Avoid jumping too high regardless of your level of practice.
33. When you jump, you should always keep your eyes on your trampoline.
34. Do not practice if you feel tired.
35. Do not leave your trampoline without an adult familiar with trampolining attending.
36. Do not allow anything to drag on or near your trampoline.
37. Do not use the trampoline when under the influence of alcohol, drugs or medication.
38. Check that your trampoline mat is dry before using it.
39. If you want to improve your practice skills, contact a certified trampoline instructor.
40. Do not use your trampoline if there is wind.
41. You can walk or jump on the mat but mustn't walk or jump on the frame or on the elastics.
42. During your practice, do not move or topple the trampoline.

D. Maintenance of the trampoline

43. Be careful not to hurt yourself at the edges when moving the product.
44. Read the assembly instructions to assemble your trampoline.
45. Inspect the trampoline before each use and replace any worn, defective, or missing parts. The following conditions could represent potential hazards:
 - (1) Missing, improperly positioned, or insecurely attached frame padding,
 - (2) Punctures, frays, tears, or holes worn in the bed or frame padding,
 - (3) Deterioration in the stitching or fabric of the bed or frame padding,
 - (4) Ruptured springs / elastics,
 - (5) A bent or broken frame,
 - (6) A sagging bed, or
 - (7) Sharp protrusions on the frame or suspension system.
46. Components supplied by the manufacturer only should be used to maintain or repair the product. To ensure optimum adhesion to the ground, the foot caps must be clean and dry.
47. Do not leave objects permanently on the jumping mat or on the elastics.
48. Avoid rubbing the elastics against a surface or another object.
49. Avoid rubbing the handlebar foams against a surface or another object.
50. If there is wear on an elastic, please replace it.

Basic jump

1. Start from a standing position with your head erect and your eyes on the frame pad.
2. Swing your arms forward and up in a circular motion.
3. Bring your feet together and point your toes downward while in the air.
4. Keep your feet about 15 inches apart when landing on the mat.

Warranty

After the date of the purchase invoice, the owner of the trampoline has a:

- Lifetime warranty on trampoline accessories breakage, non-human damage can always contact the after-sales service to replace the replacement parts
- Within three months of purchase only replace not repair, any problems can contact customer service to replace the new product
- The warranty becomes defunct if:
- This product is used incorrectly and/or carelessly and is used in such a way that it does not comply with its purpose.
- This product is not assembled and maintained according to the instruction booklet.
- Technical repairs to this product are not carried out professionally.
- Parts, which are mounted afterwards, do not comply with the technical specifications of the product concerned or are mounted incorrectly.
- Defects are a result of climatic influences such as corrosion, UV rays or normal disintegration.
- The product is rented out or was made available to various unspecified persons in any other manner.

MADE IN CHINA

