

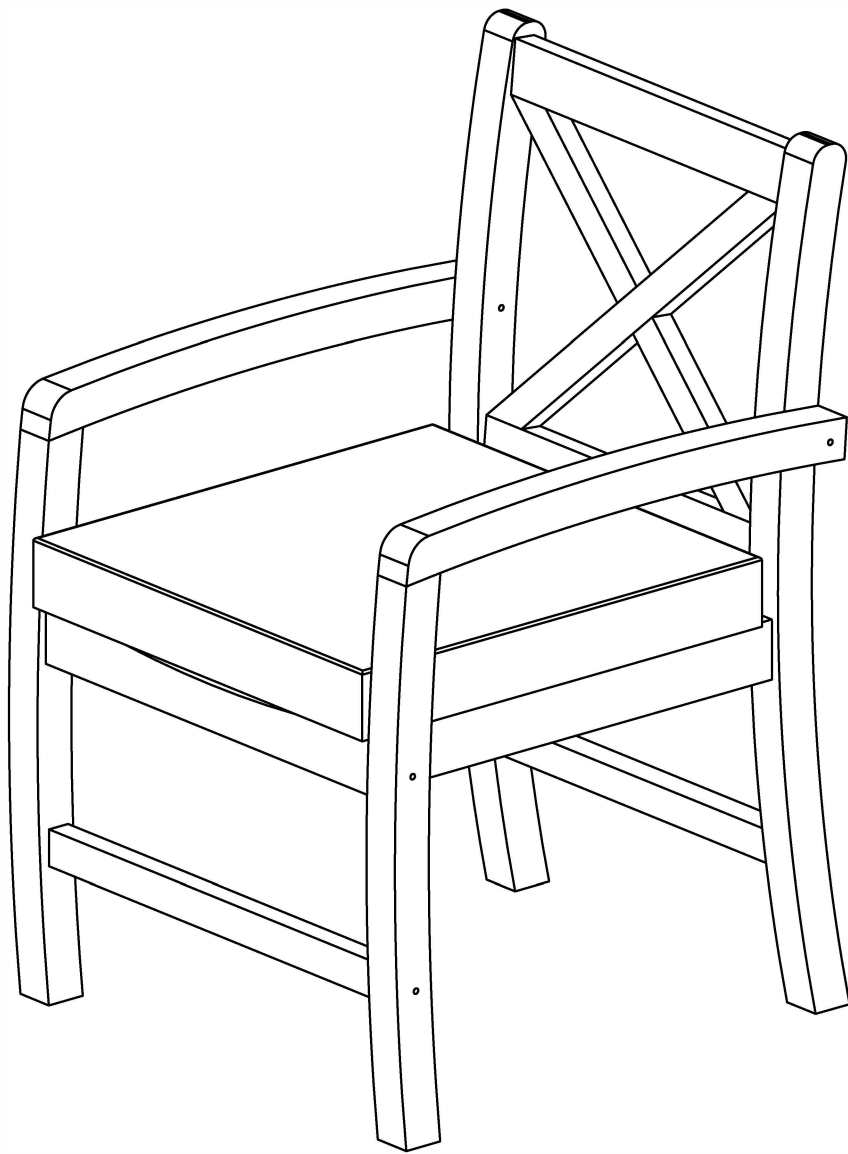

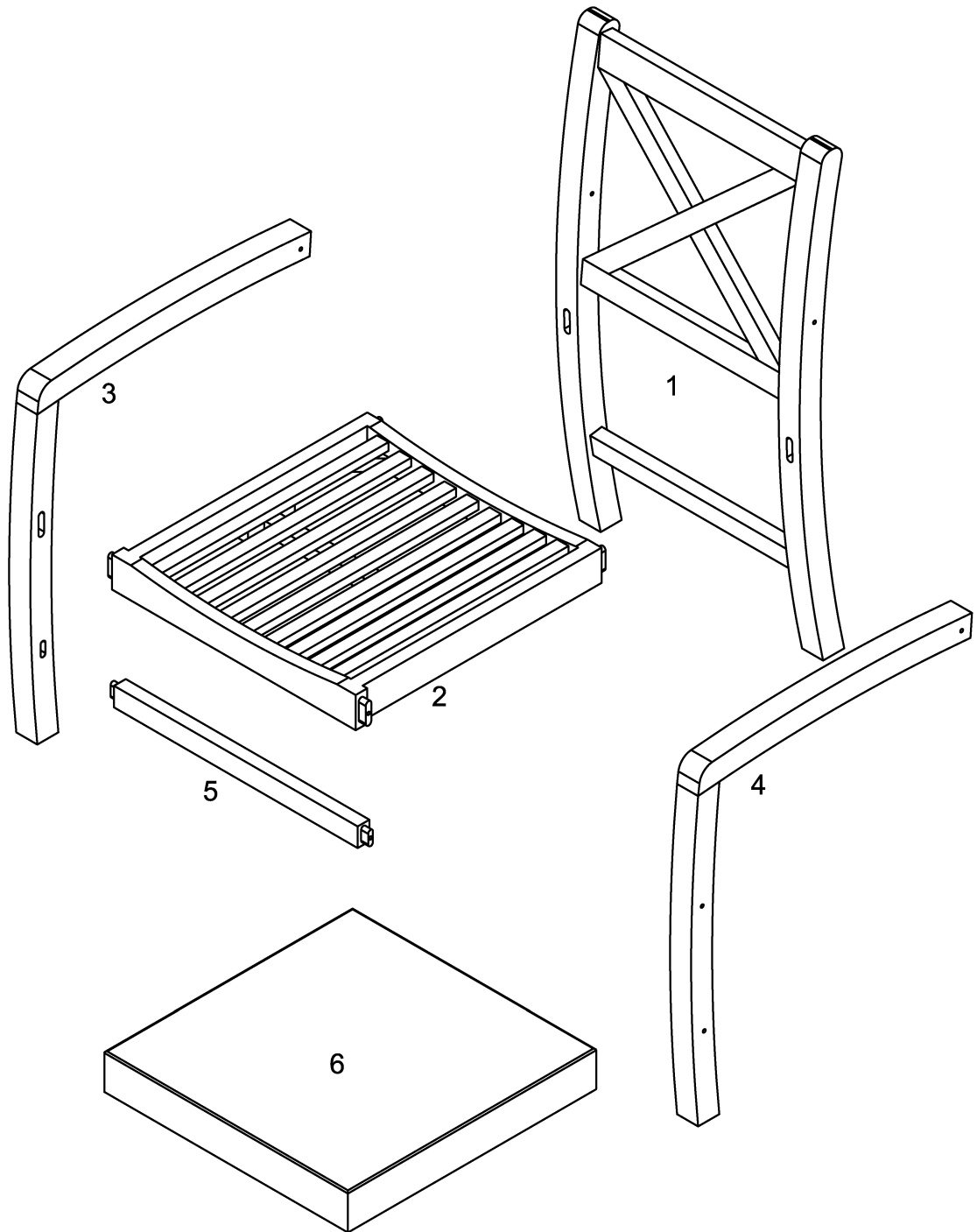

# Assembly Instructions



# Parts List

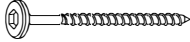

# Hardware List

A		M7*90	Screw	12 pcs
B		M8*80	Bolt	4 pcs
C			Nut	4 pcs
D		M4	Wrench	2 pcs

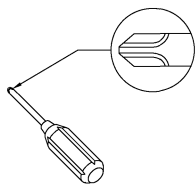

head screwdriver required for assembly  
(not included)

*The hardware quantities listed above are required for proper assembly.  
Some extra hardware may also have been included.*

# Step 1

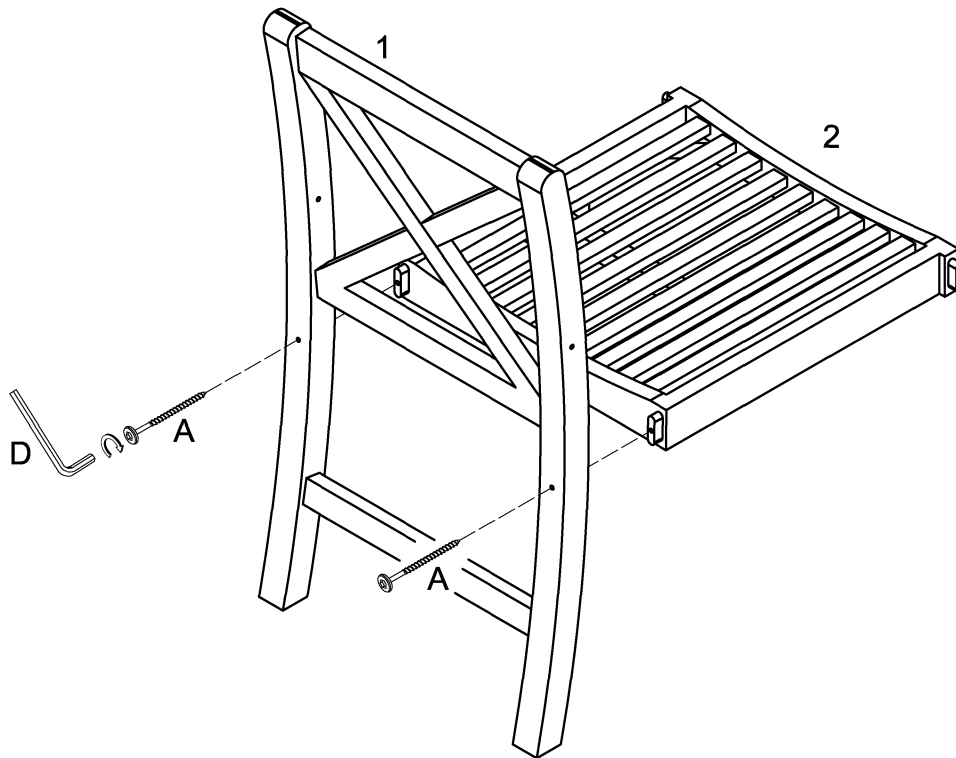

Use Wrench (D), Screw (A) to secure the Back Frame (1) to the Seat Frame (2).

# Step 2

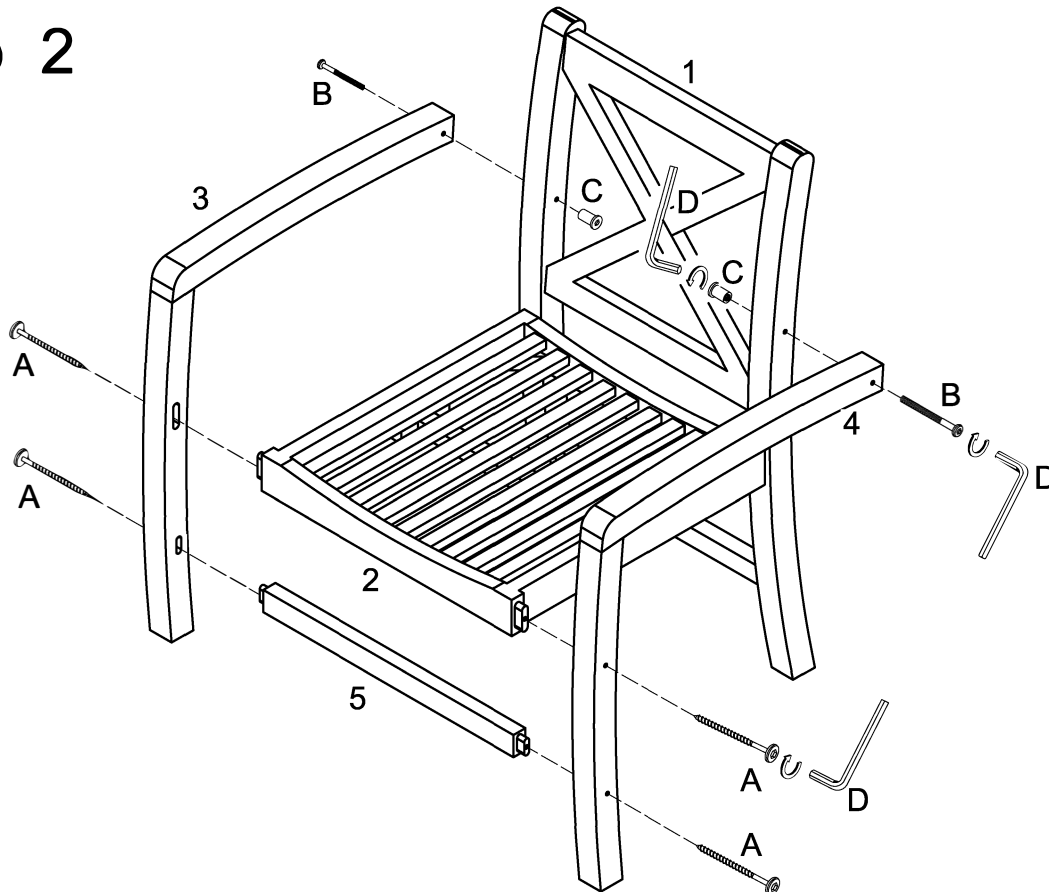

Use Wrench (D), Secure (A), Bolt (B), and Nut (C) to secure the Side Frame (3,4) to the Back Frame (1), Seat Frame (2), and Support Bar (5).

## Step 3

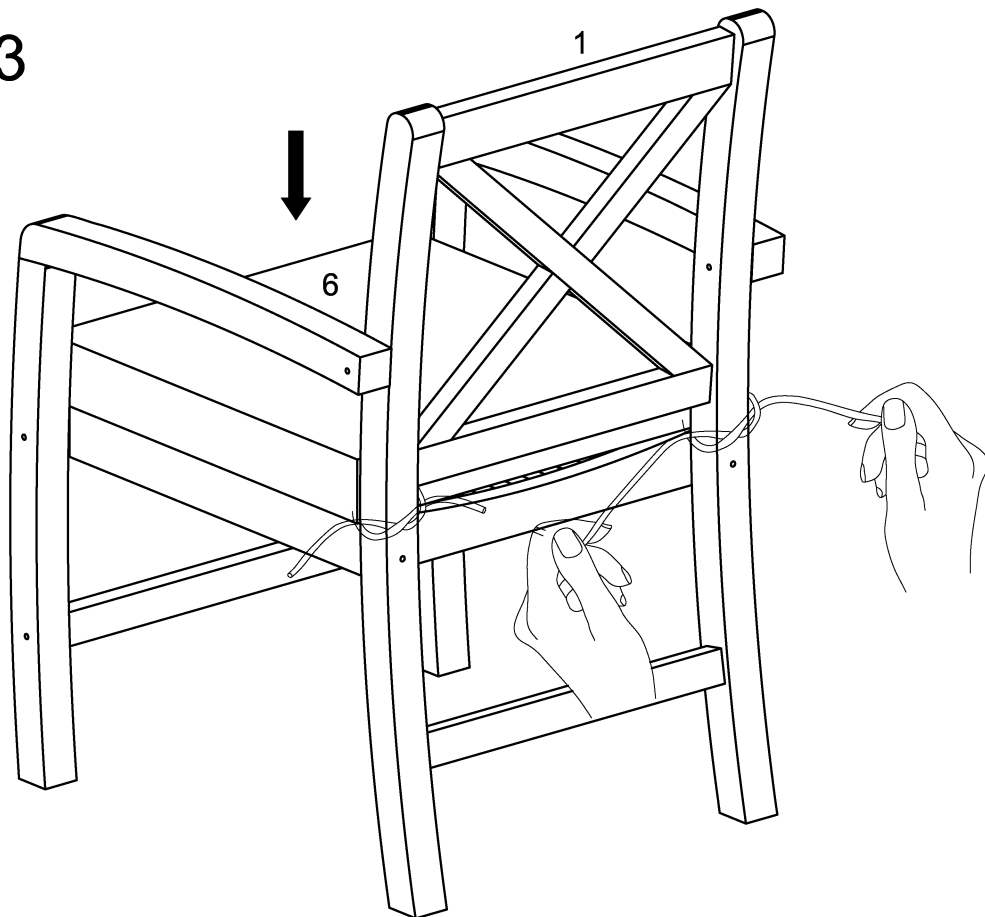

Put the Seat Cushion (6) on top of the Seat Frame (2). And tie the cushion rope to the Back Frame (1) as per diagram.

## Step 4

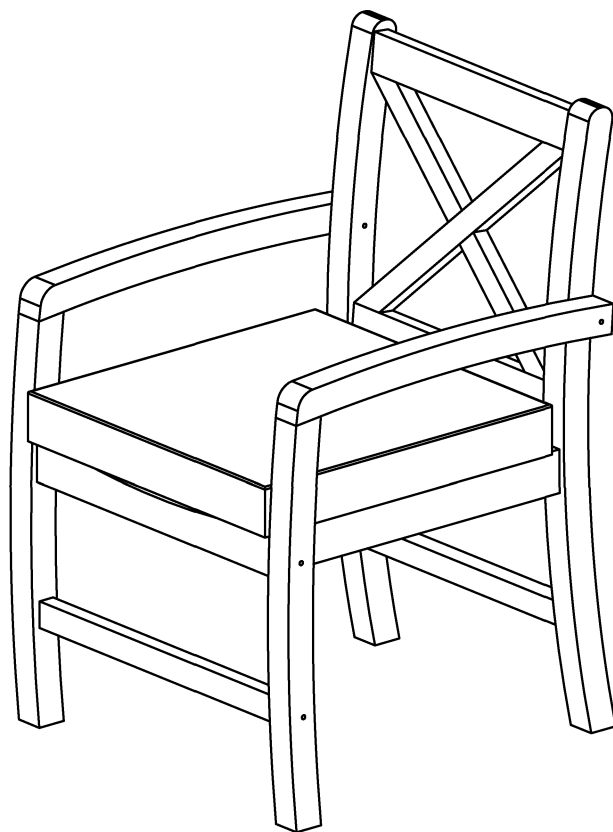

**Final Assembly**