

# *ASSEMBLY INSTRUCTIONS*

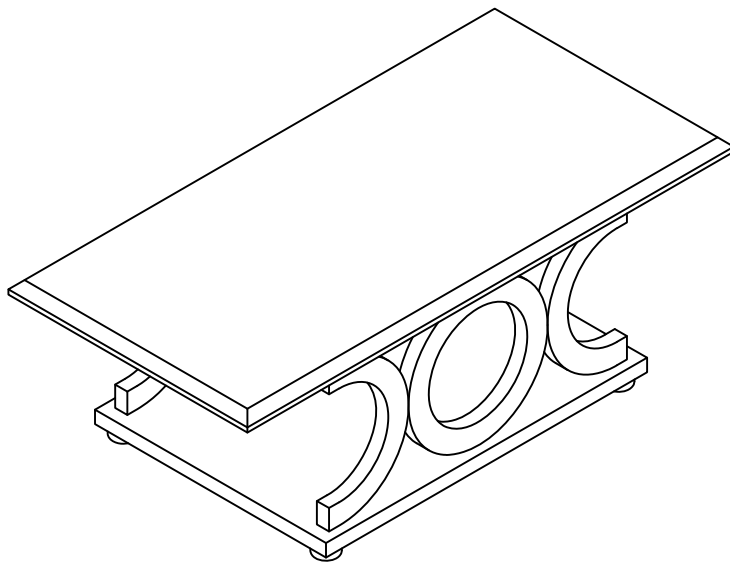

***Coffee Table***

## ASSEMBLY INSTRUCTIONS

### ASSEMBLY TIPS:

- 1.Remove hardware from box and sort by size.
- 2.Please check to see that all hardware and parts are present prior to start of assembly.
- 3.Please follow attached instructions in the same sequence as numbered to assure fast & easy assembly.

### Warning !!

1. Don't attempt to repair or modify parts that are broken or defective. Please contact the store immediately.
2. This product is for home use only and not intended for commercial establishment.



**ASSEMBLY TIME**

**30 MINUTES**

### PARTS IDENTIFICATION

(A) TOP PANEL

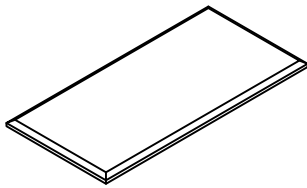

1 PC

(C) CIRCULAR SUPPORT



2 PCS

(B) BASE

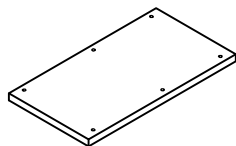





1 PC

(D) ARC LEG

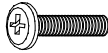
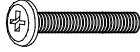

4 PCS

## HARDWARE IDENTIFICATION

1	SMALL FLAT-HEAD SCREW	M6x40mm		4pcs
2	BIG FLAT-HEAD SCREW	M6x60mm		2pcs
3	WOOD SCREW	Ø7x58mm		10pcs
4	PLASTIC PAD WITH SCREW	Ø55x25mm		4pcs
5	STICKER	Ø18mm		4pcs

# ASSEMBLY INSTRUCTIONS

## STEP 1

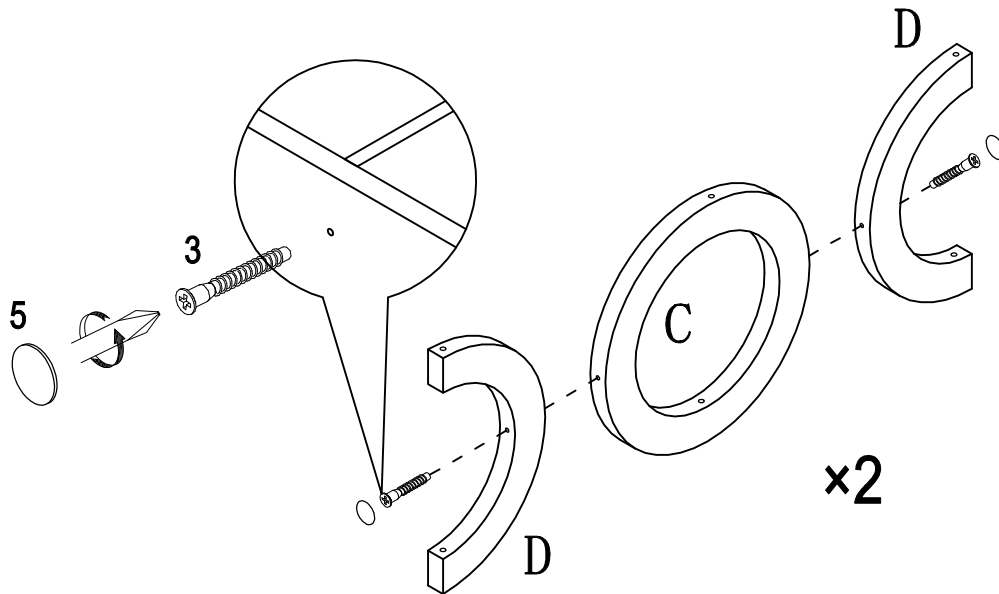

## STEP 2

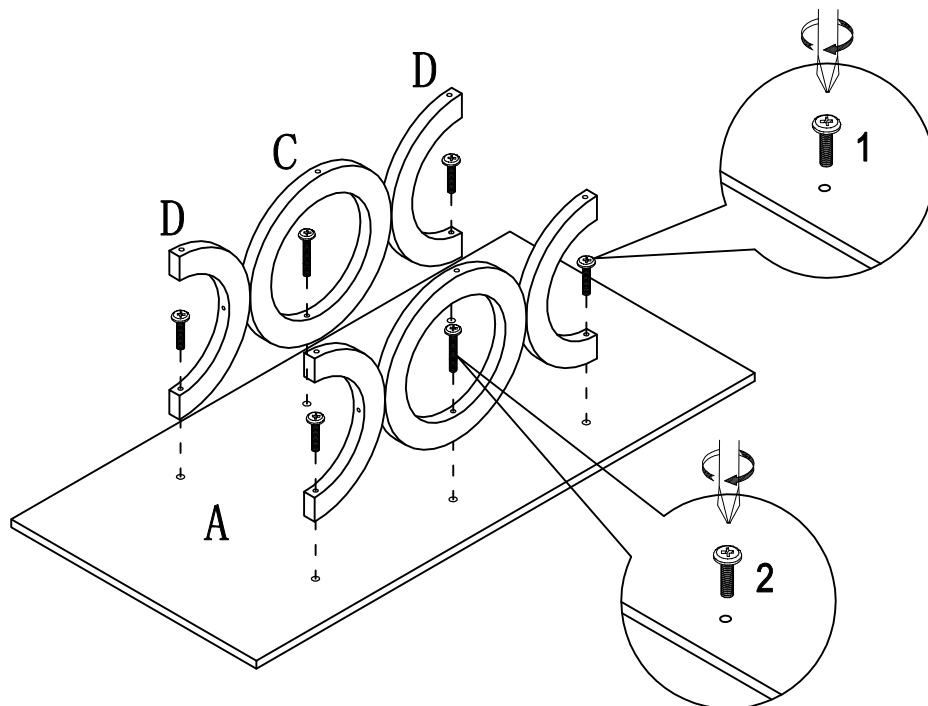

# ASSEMBLY INSTRUCTIONS

## STEP 3

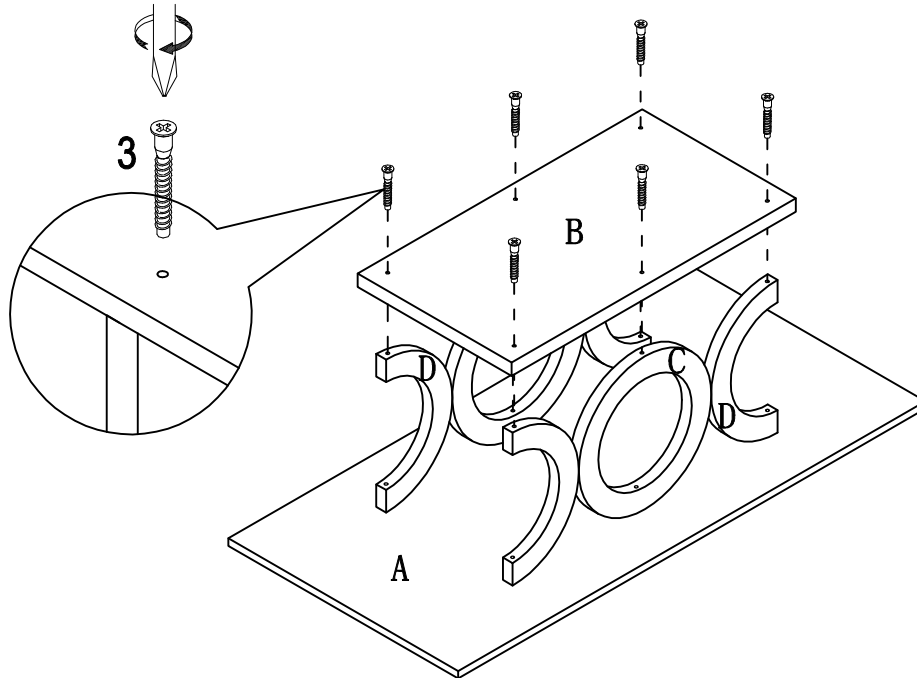

## STEP 4

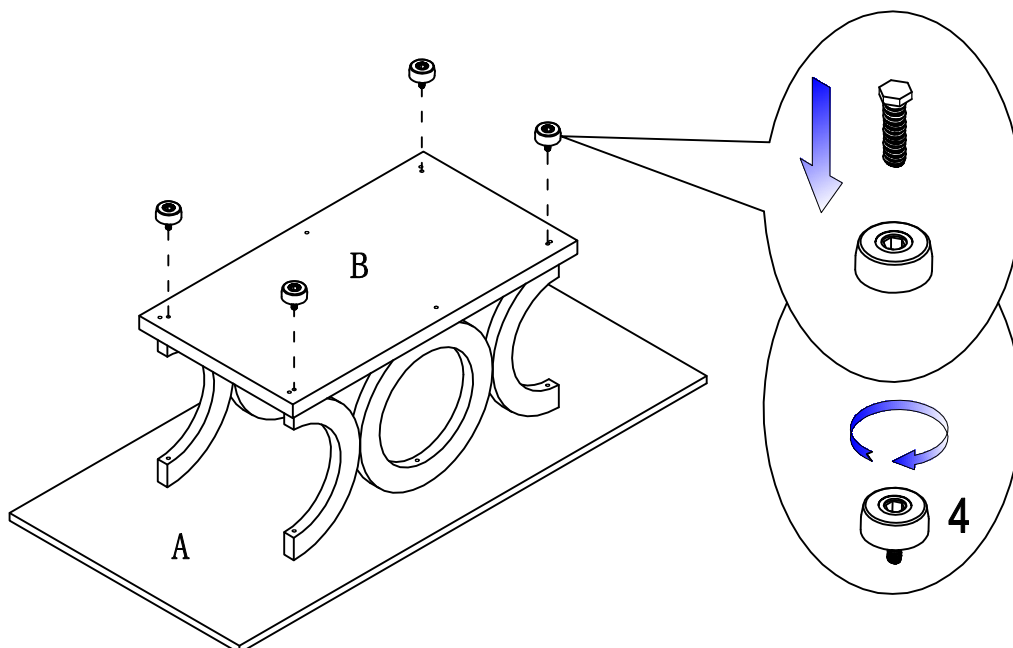

# DIMENSION

