



Vestil Manufacturing Company

2999 North Wayne Street, P.O. Box 507, Angola, IN 46703

Telephone: (260) 665-7586 -or- Toll Free (800) 348-0868

Fax: (260) 665-1339

www.vestil.com

info@vestil.com

H-SERIES HOPPERS

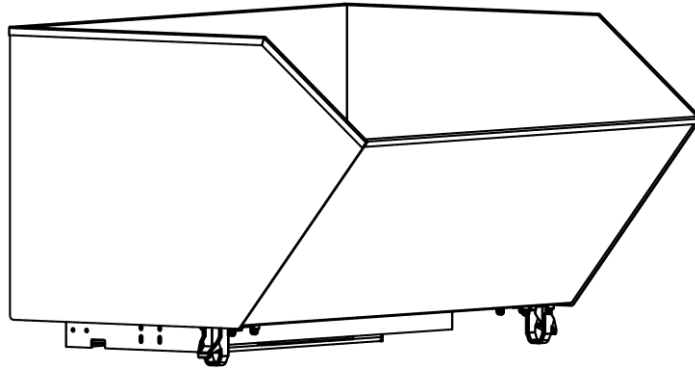

Receiving Instructions

After delivery, remove the packaging from the product. Inspect the product closely to determine whether it sustained damage during transport. If damage is discovered, record a complete description of it on the bill of lading. If the product is undamaged, discard the packaging.

NOTE: The end-user is solely responsible for confirming that product design, use, and maintenance comply with laws, regulations, codes, and mandatory standards applied where the product is used.

Technical Service & Replacement Parts

For answers to questions not addressed in these instructions and to order replacement parts, labels, and accessories, call our Technical Service and Parts Department at (260) 665-7586. The department can also be contacted online at <https://www.vestil.com/page-parts-request.php>.

Electronic Copies of Instruction Manuals

Additional copies of this manual may be downloaded from <https://www.vestil.com/page-manuals.php>.

Table of Contents		Table of Figures	
	Page		Page
Specifications.....	2	Replacement Release Handle with Cable Kit.....	2
Signal Words.....	3	Exploded view & bill of materials: H-25 series hoppers..	4
Safety Instructions.....	3	Exploded view & bill of materials: H-33 series hoppers..	5
Installing H-BD-L Option.....	11	Exploded view & bill of materials: H-50 series hoppers..	6
National Standards.....	12	Exploded view & bill of materials: H-75 series hoppers..	7
Loading the Chute.....	12	Exploded view & bill of materials: H-100 series hoppers	8
Using the Cable & Handle.....	12	Exploded view & bill of materials: H-150 series hoppers	9
Using the Bump & Dump Option..	13	Exploded view & bill of materials: H-200-HD.....	10
Stacking Hoppers.....	14	Exploded view & bill of materials: H-BD-L.....	11
Record of Satisfactory Condition	14		
Inspections & Maintenance.....	14		
Labeling Diagram.....	15		
Limited Warranty.....	16		

SPECIFICATIONS

Documents that provide specifications for H-series hoppers are available online to anyone who visits Vestil's website. Specifications include dimensions, net weight, and capacity information. Navigate to <https://www.vestil.com/product.php?FID=445>. Scroll to the *Product Specifications Table* portion of the page. Find the entry for the hopper you purchased and click the button in the "PDF" column that looks like a pencil inside a blue-bordered box. A PDF file will open. This file is the specifications document. Print a copy of the document and keep it with your copy of this manual.

The following is an exemplar specifications document for model H-33-LD.

LOW PROFILE 90° SELF DUMPING HOPPER - H-33-LD

*** ANY ADDITIONS, DELETIONS, OR OMISSIONS MUST BE CORRECTED ON THIS DRAWING AS THIS DRAWING WILL BE CONSIDERED ALL INCLUSIVE ***
ALL GRAPHICS PROVIDED ARE FOR REFERENCE ONLY. IF CERTAIN DIMENSIONS ARE CRITICAL PLEASE VERIFY THOSE DIMENSIONS WITH YOUR SALESPERSON

APPROX WEIGHT: 188.85 lbs.
DOES NOT INCLUDE WEIGHT OF POWER OR PACKAGING!!!

**** ADDITION OF CASTERS MAY CHANGE WEIGHT CAPACITY BASED ON CASTER RATING**

STANDARD FEATURES

MODEL NUMBER: H-33-LD
OVERALL WIDTH: 27"
OVERALL LENGTH: 48 1/4"
OVERALL HEIGHT: 22 7/16"
BIN INSIDE WIDTH 24"
BIN INSIDE LENGTH 43 7/16"
BIN INSIDE HEIGHT 17 5/8"
CAPACITY: 2,000 LBS.
VOLUME: 1/3 CU. YRD.
DURABLE BAKED IN POWDER COATED BLUE FINISH

APPROX. WEIGHT / LOST LOAD = 188.85
MINIMUM EFFECTIVE THICKNESS =
VERTICAL CENTER OF GRAVITY = 8"
HORIZONTAL CENTER OF GRAVITY = 17 7/8"

NEVER EXCEED LOAD CENTER RATING PER FORKTRUCK MANUFACTURERS GUIDELINES.
DO NOT USE THIS FORK TRUCK ATTACHMENT IF LOAD WILL EXCEED FORK TRUCK MANUFACTURER'S LOAD CENTER RATING

SPECIAL FEATURES

NONE

DIMENSION TOLERANCE ± 1/4"

A
P
P
R
O
V
A
L

I, THE UNDERSIGNED, AGREE THAT THE PRODUCT AS REPRESENTED SATISFIES DESIGN AND DIMENSION REQUIREMENTS. I ALSO ACKNOWLEDGE MY DUTY TO CONFIRM PRODUCT AND INSTALLATION COMPLIANCE WITH ALL APPLICABLE FEDERAL, STATE AND LOCAL REGULATIONS AND STANDARDS.

UNITS REQUIRING APPROVAL DRAWINGS OR MODIFIED ARE NON-RETURNABLE
 As drawn As marked

Signed: _____ Date: _____

Printed Name: _____

LEAD TIME WILL START UPON RECEIPT OF SIGNED APPROVAL DRAWING

DISTRIBUTOR'S NAME: VESTIL MANUFACTURING	P.O.# X
DRAWN BY: JWW	W.O.# X
DATE: 9/28/2020	SALES: X
REFERENCE: X	SCALE: 1:16
QUOTED LEAD TIME: X	FILE NAME: 37-007-147

NOTE: If your model is not included on the webpage or you cannot access the document, contact the [Technical Service Dept.](#) Contact information is provided on the front page of this manual.

REPLACEMENT RELEASE HANDLE WITH CABLE KIT (37-154-044 REV. B)

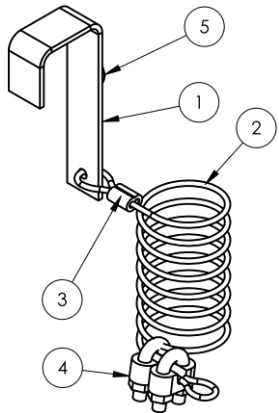

Item	Part no.	Description	Qty.
1	37-025-002	HANDLE, CHUTE RELEASE	1
2	37-145-001	SPECIALTY HARDWARE CABLE	1
3	43383	SWAGE SLEEVE Ø1/8" X 5/8" LONG	1
4	43403	1/4" WIRE CLAMP	2
5	37-145-022	MAGNET, 20MM X 5MM THICK	1

SIGNAL WORDS

SIGNAL WORDS in this manual draw the reader's attention to important safety-related messages.

⚠ DANGER	Identifies a hazardous situation which, if not avoided, <u>WILL</u> result in DEATH or SERIOUS INJURY. Use of this signal word is limited to the most extreme situations.
⚠ WARNING	Identifies a hazardous situation which, if not avoided, COULD result in DEATH or SERIOUS INJURY.
⚠ CAUTION	Indicates a hazardous situation which, if not avoided, COULD result in MINOR or MODERATE injury.
NOTICE	Identifies practices likely to result in product/property damage, such as operation that might damage the product.

SAFETY INSTRUCTIONS

Vestil strives to identify foreseeable hazards associated with its products. However, material handling is dangerous and no manual can address every conceivable risk. The most effective way to prevent injury is to apply sound judgment whenever using this device. Acquire a copy of the latest version of ANSI B56.1 ("B56.1" or the "Standard"). The Standard is freely downloadable on www.ITSDF.org. Apply all portions of Part II "For the User" that concern the use of attachments and removable attachments. The following recommendations are intended to complement the provisions of B56.1.

⚠ WARNING

Risk of serious personal injuries or death! Always apply the following safety instructions.

- Before this product may be used, U.S. Occupational Safety and Health Administration rule 1910.178(a)(4) and (a)(5) require that the owner/user: 1) Obtain written approval from the manufacturer(s) of all forklifts [or from a professional engineer] that will be used with the hopper; 2) Change capacity, operation, & maintenance instruction plates, tags, or decals accordingly; AND 3) Mark the forklift truck to identify the beam and show the approximate weight of the truck and beam combination at maximum elevation with load laterally centered. Requirements are published at https://www.osha.gov/pls/oshaweb/owadisp.show_document?p_table=STANDARDS&p_id=9828
- DO NOT use this hopper with rough terrain lift trucks or telehandlers (boom trucks). ONLY use this hopper with high lift fork trucks utilizing a vertical mast and carriage. DO NOT mount the hopper on stackers or manually propelled lift trucks.
- DO NOT operate the truck carrying this hopper on unimproved surfaces. Only operate on concrete or asphalt surfaces.
- *Read & understand this entire manual before using or servicing the hopper.*
- Inspect the hopper as directed in the **INSPECTIONS & MAINTENANCE** section on p. 14. DO NOT use it unless it is in **SATISFACTORY CONDITION**. See **RECORD OF SATISFACTORY CONDITION** on p. 14.
- DO NOT use the hopper if the carriage chain is damaged or missing. DO NOT elevate the hopper with a fork truck until it is securely connected to the carriage of the truck with the carriage chain.
- DO NOT fill the hopper beyond its maximum rated load. See **SPECIFICATIONS** tables on page 2.
- NO ONE should travel under the hopper at any time while it is elevated.
- NEVER wrap the release cable around your hand, fingers, or any other part of your body!
- **Hoppers with lifting lugs** can be lifted with overhead hoists and cranes. DO NOT lift a hopper unless the chute is securely latched to the frame.
- DO NOT allow people to ride on or in the hopper.
- DO NOT use the hopper if any label is unreadable or missing. Apply replacement labels before returning the hopper to service. See **LABELING DIAGRAM** on p. 15.
- ALWAYS apply proper lift truck operation techniques learned during your training program. Before raising the hopper from the floor, tilt the (forklift) mast toward the cab of the truck to ensure that the hopper will not slide off of the forks.
- DO NOT modify the hopper without first obtaining written approval from Vestil! Unapproved modifications might make the hopper unsafe to use and automatically void the **LIMITED WARRANTY** on p. 16.
- DO NOT dump the hopper UNLESS everyone in the vicinity is a safe distance away from the dumping site.
- DO NOT dump the hopper unless the forklift is on an even, level surface.
- DO NOT exceed the load ratings or fill the hopper above the side walls. Injury to personnel or permanent damage to the equipment could result from overloading.

NOTE: This self-dumping hopper helps to prevent non-compliance with US Federal OSHA rule 1910.178(m)(5). Subpart 1910.178(m)(5)(iii) requires operators of powered trucks to fully lower the "load engaging means" [forks], neutralize truck controls, and set brakes whenever they dismount a lift truck & remain within 25ft of it. Operators can remain at the controls of their trucks throughout the dumping process while using this hopper.

H-25 SERIES HOPPERS EXPLODED VIEW AND BILL OF MATERIALS

37-006-035

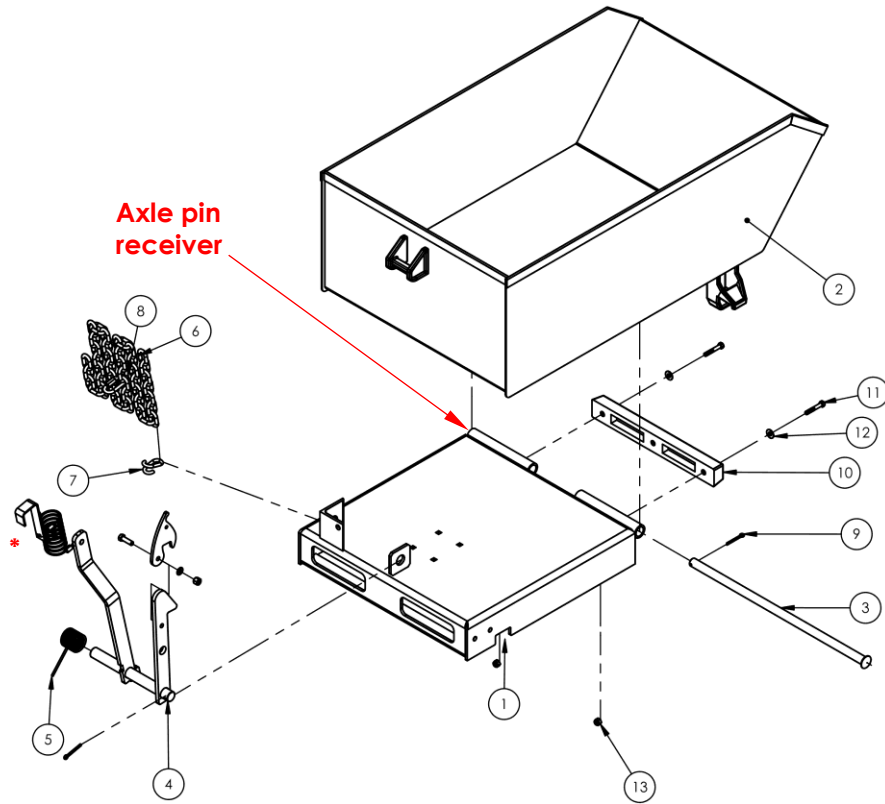

*37-514-044 release handle and cable replacement kit shown on [p. 2](#).

Item	Part no.	Description	Qty.
1	37-514-082	WELDMENT, FRAME, BASE	1
2	37-545-032	WELDMENT, CHUTE H-25-LD	1
	37-545-003	H-25-MD	1
	37-545-037	H-25-HD	1
3	37-112-046	PIN, CONNECTING ROD	1
4	37-537-021	WELDMENT, LOCK, RELEASE LEVER ASSEMBLY	1
5	37-146-005	SPRING,TORSION,HOPPER RELEASE	1
6	09-145-018	CHAIN, 5/16" x 56" LG	1
7	99-145-084	LAP LINK, 5/16" X 1 1/2"	1
8	99-145-053	5/16" QUICK LINK	1
9	65127	COTTER PIN Z PLATED, 3/16 x 2	2
10	29-048-087	BUMPER, RUBBER	1
11	11061	HHCS #2 Z PLATED, GRADE A, Ø 5/16 - 18 x 2" LG	2
12	33006	FLAT WASHER,ZINC PLATED,USS, Ø5/16"	2
13	37021	NYLON INSERT LOCK NUT, GRADE 2, ZINC FINISH, 5/16"-18	2

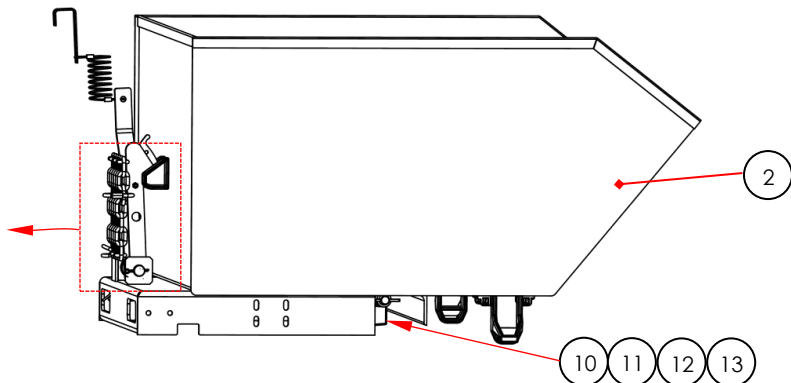
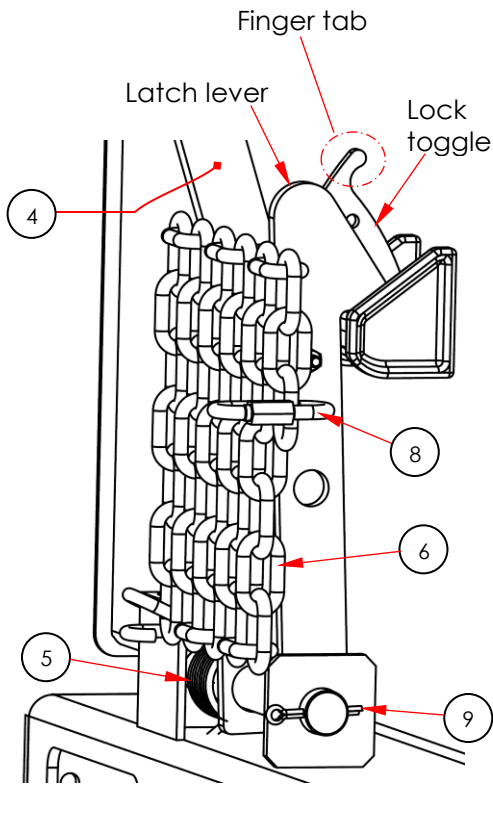

H-33 SERIES HOPPERS EXPLODED VIEW AND BILL OF MATERIALS

37-006-147

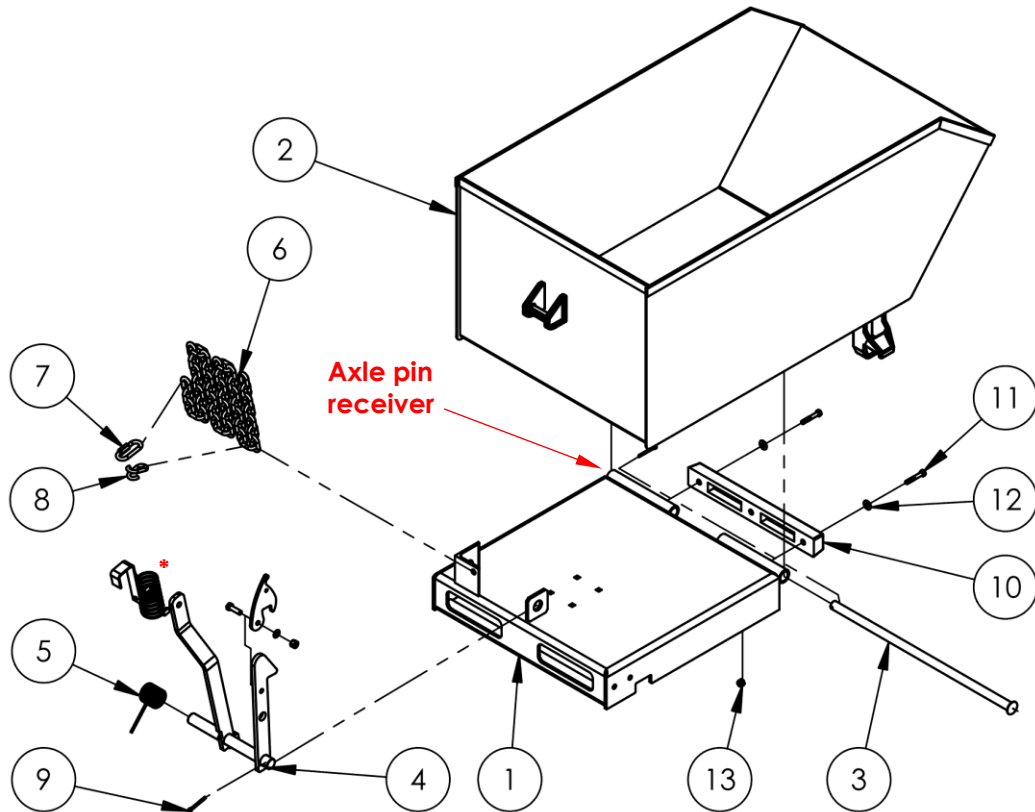

*37-514-044 release handle and cable replacement kit shown on [p. 2](#).

Item	Part no.	Description	Qty.
1	37-514-082	WELDMENT, FRAME, BASE	1
2	37-545-139	H-33-LD	1
	37-545-140	H-33-MD	1
	37-545-141	H-33-HD	1
3	37-112-046	PIN, CONNECTING ROD	1
4	37-537-021	WELDMENT, LOCK, RELEASE LEVER ASSEMBLY	1
5	37-146-005	SPRING,TORSION,HOPPER RELEASE	1
6	09-145-018	CHAIN, 5/16" x 56" LG	1
7	99-145-053	5/16" QUICK LINK	1
8	99-145-084	LAP LINK, 5/16" X 1 1/2"	1
9	65127	COTTER PIN Z PLATED, 3/16 x 2	2
10	29-048-087	BUMPER, RUBBER	1
11	11061	HHCS #2 Z PLATED, GRADE A, 5/16 - 18 x 2" LG	2
12	33006	FLAT WASHER,ZINC PLATED,USS, Ø5/16"	2
13	37021	NYLON INSERT LOCK NUT, GRADE 2, ZINC FINISH, 5/16"-18	2

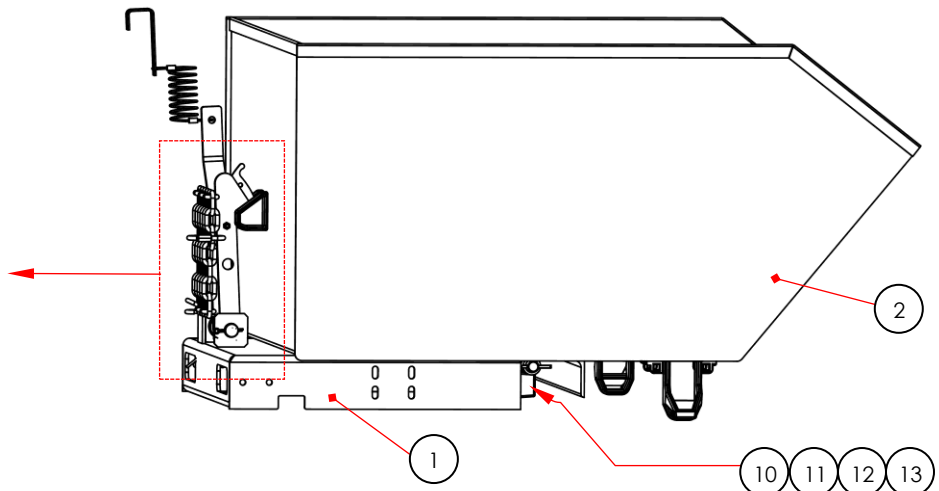
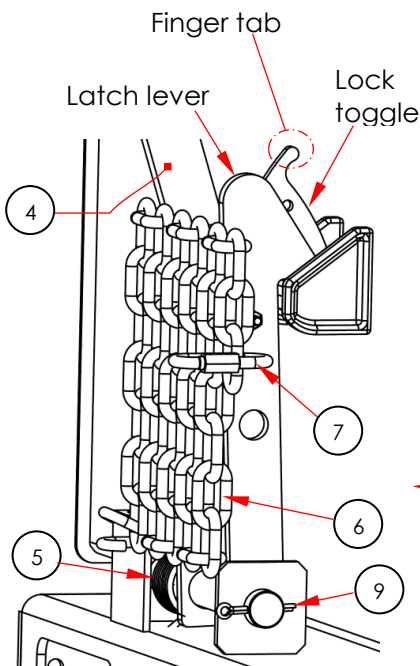

H-50 SERIES HOPPERS EXPLODED VIEW AND BILL OF MATERIALS

37-006-036

*37-514-044 release handle and cable replacement kit shown on [p. 2](#).

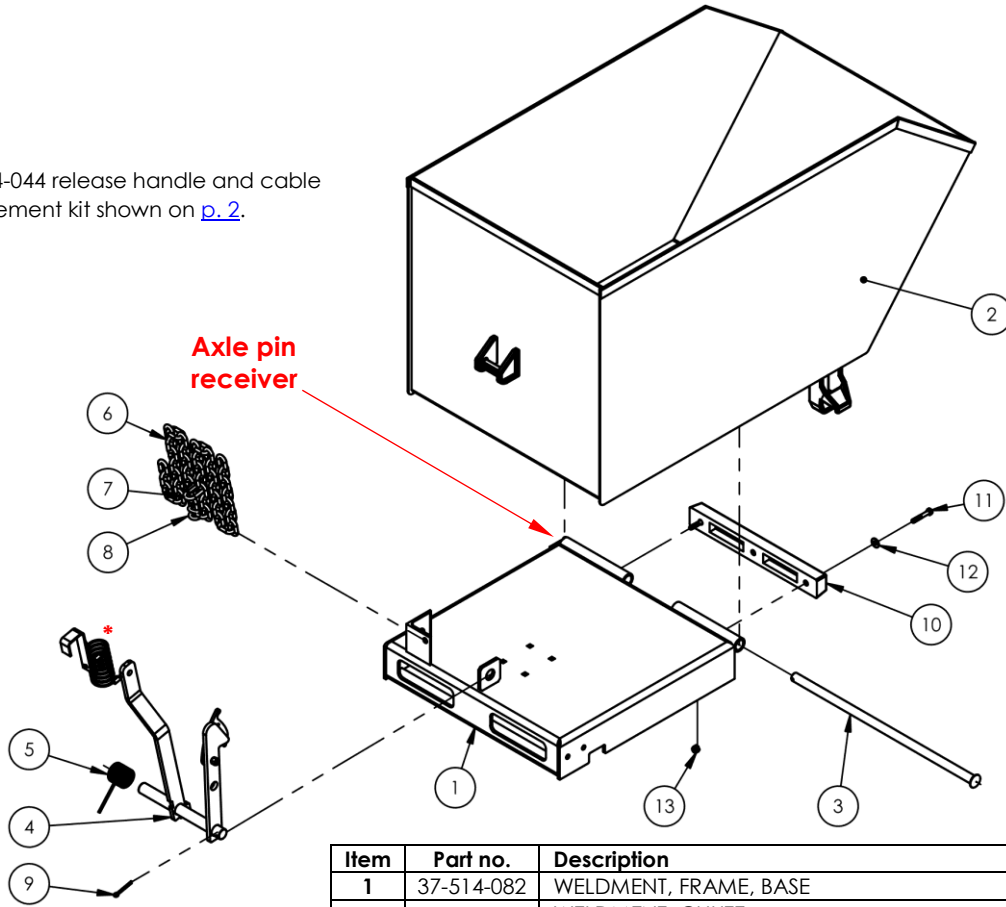

Item	Part no.	Description	Qty.
1	37-514-082	WELDMENT, FRAME, BASE	1
2	37-545-033	WELDMENT, CHUTE H-50-LD	1
	37-545-004	H-50-MD	1
	37-545-038	H-50-HD	1
3	37-112-046	PIN, CONNECTING ROD	1
4	37-537-021	WELDMENT, LOCK, RELEASE LEVER ASSEMBLY	1
5	37-146-005	SPRING, TORSION, HOPPER RELEASE	1
6	09-145-018	CHAIN, 5/16" x 56" LG	1
7	99-145-053	5/16" QUICK LINK	1
8	99-145-084	LAP LINK, 5/16" X 1 1/2"	1
9	65127	COTTER PIN Z PLATED, 3/16 x 2	2
10	29-048-087	BUMPER, RUBBER	1
11	11061	HHCS #2 Z PLATED, GRADE A, Ø 5/16 - 18 x 2" LG	2
12	33006	FLAT WASHER, ZINC PLATED, USS, Ø5/16"	2
13	37021	NYLON INSERT LOCK NUT, GRADE 2, ZINC FINISH, 5/16"-18	2

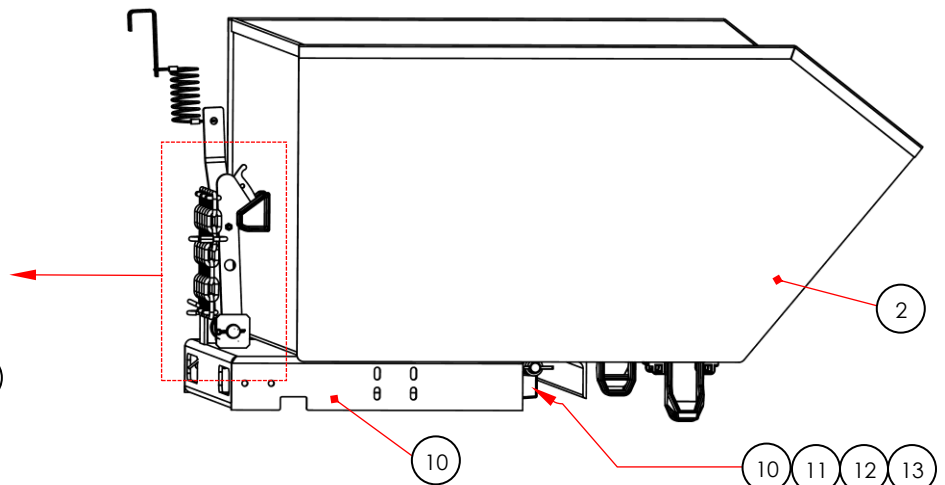
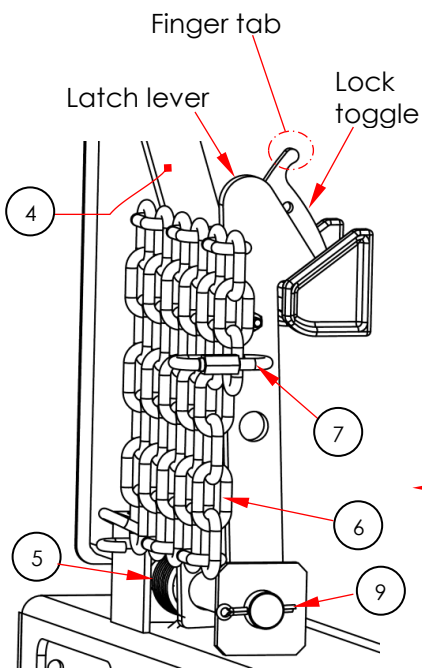

H-75 SERIES HOPPER EXPLODED VIEW AND BILL OF MATERIALS

37-006-150

*37-514-044 release handle and cable replacement kit shown on [p. 2](#).

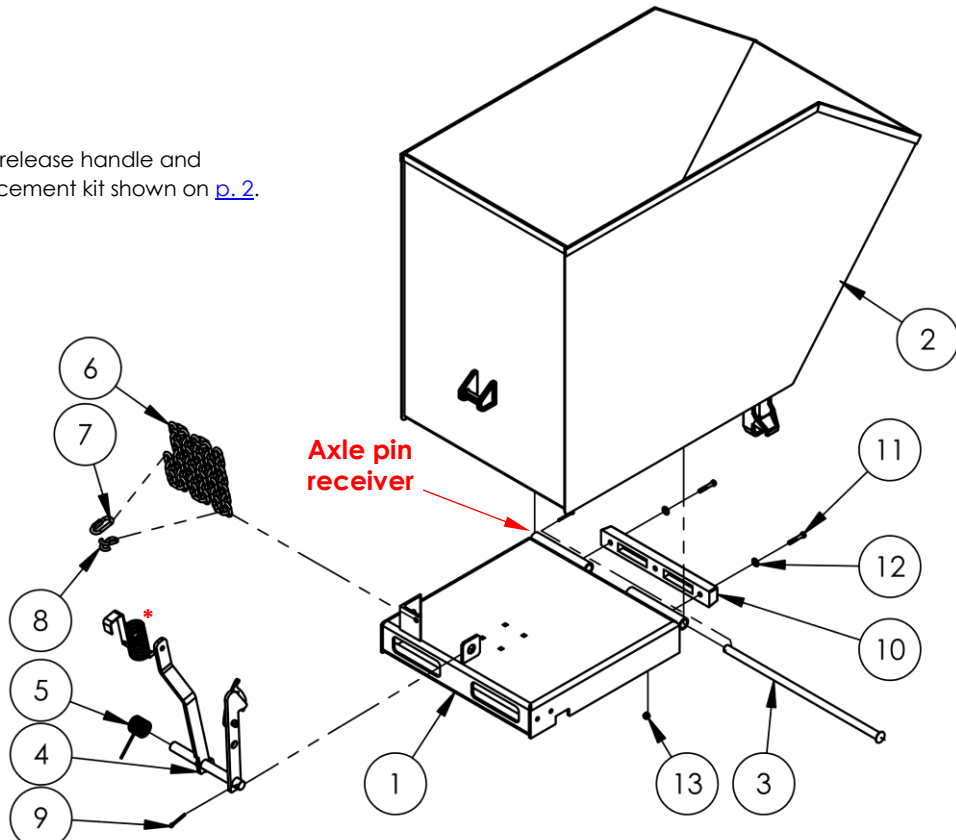

Item	Part no.	Description	Qty.
1	37-514-082	WELDMENT, FRAME, BASE	1
2	37-545-142	WELDMENT, CHUTE H-75-LD	1
	37-545-143	H-75-MD	1
	37-545-144	H-75-HD	1
3	37-112-046	PIN, CONNECTING ROD	1
4	37-537-021	WELDMENT, LOCK, RELEASE LEVER ASSEMBLY	1
5	37-146-005	SPRING, TORSION, HOPPER RELEASE	1
6	09-145-018	CHAIN, 5/16" x 56" LG	1
7	99-145-053	5/16" QUICK LINK	1
8	99-145-084	LAP LINK, 5/16" X 1 1/2"	1
9	65127	COTTER PIN Z PLATED, 3/16 x 2	2
10	29-048-087	BUMPER, RUBBER	1
11	11061	HHCS #2 Z PLATED, GRADE A, Ø 5/16 - 18 x 2" LG	2
12	33006	FLAT WASHER, ZINC PLATED, USS, Ø5/16"	2
13	37021	NYLON INSERT LOCK NUT, GRADE 2, ZINC FINISH, 5/16"-18	2

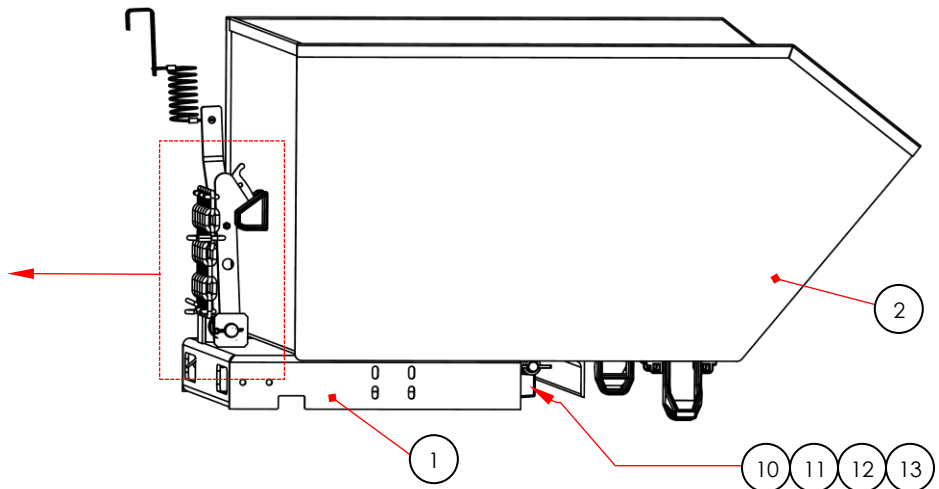
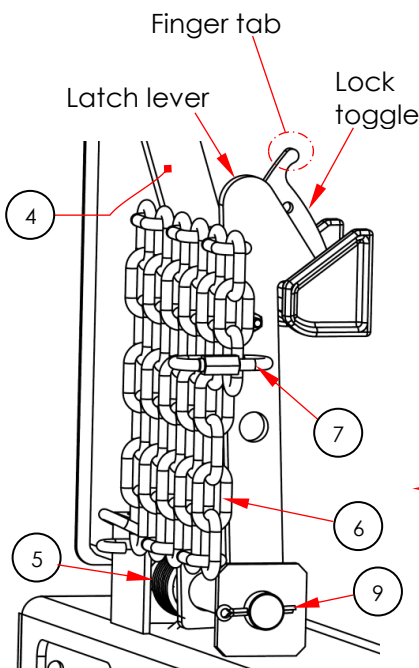

H-100-SERIES HOPPERS EXPLODED VIEW AND BILL OF MATERIALS

37-006-005

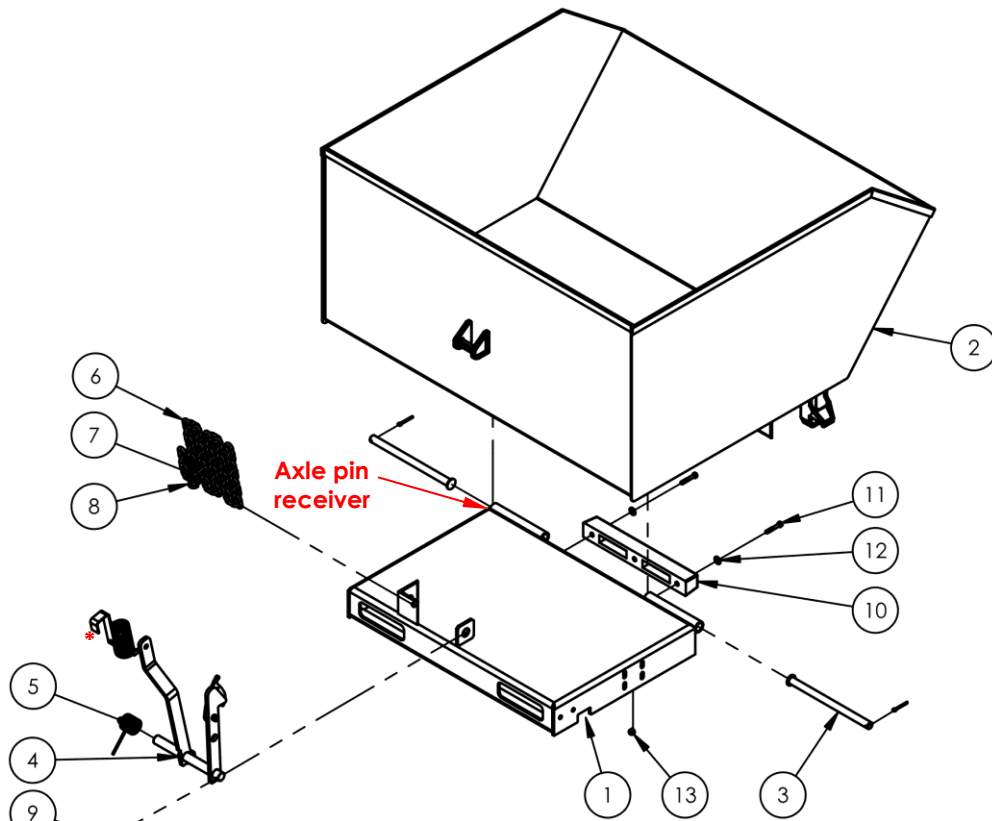

*37-514-044
release handle
and cable
replacement kit
shown on [p. 2](#).

Item	Part no.	Description	Quantity
1	37-514-083	WELDMENT, FRAME, BASE	1
2	37-545-034	WELDMENT, CHUTE	1
	37-545-008	H-100-LD	1
	37-545-039	H-100-MD	1
3	37-112-045	PIN, HINGE AXLE	2
4	37-537-021	WELDMENT, LOCK, RELEASE LEVER ASSEMBLY	1
5	37-146-005	SPRING, TORSION, HOPPER RELEASE	1
6	09-145-018	CHAIN, 5/16" x 56" LG	1
7	99-145-053	5/16" QUICK LINK	1
8	99-145-084	LAP LINK, 5/16" X 1 1/2"	1
9	65127	COTTER PIN Z PLATED, 3/16 x 2	3
10	29-048-061	BUMPER, RUBBER	1
11	11061	HHCS #2 Z PLATED, GRADE A, Ø 5/16 - 18 x 2" LG	2
12	33006	FLAT WASHER, ZINC PLATED, USS, Ø5/16"	2
13	37021	NYLON INSERT LOCK NUT, GRADE 2, ZINC FINISH, 5/16"-18	2

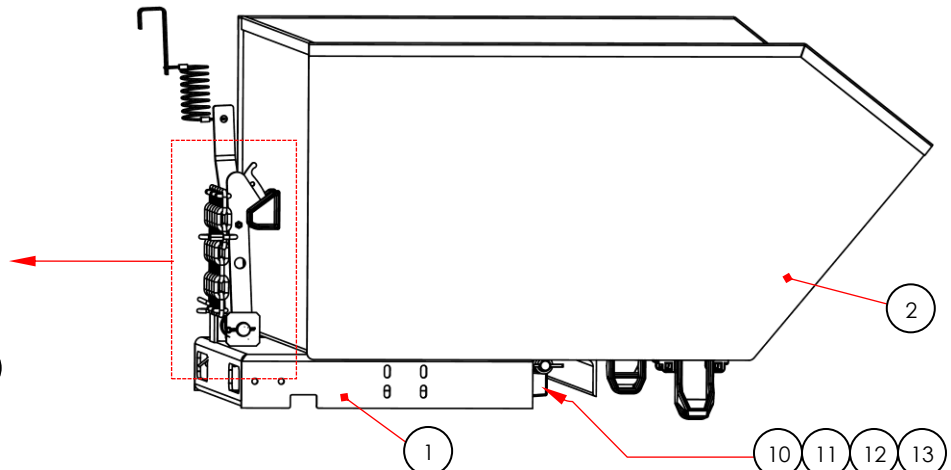
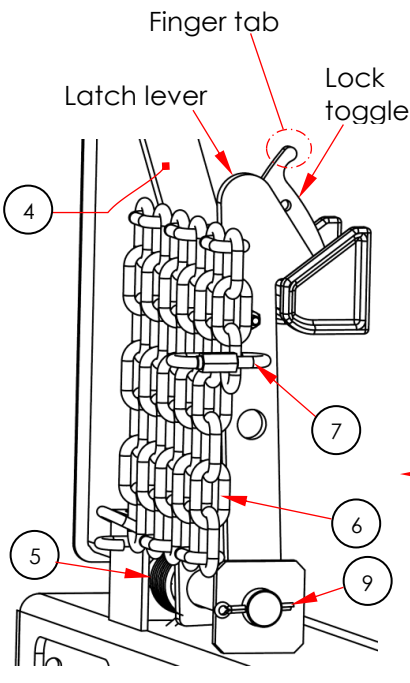

H-150-SERIES HOPPERS EXPLODED VIEW AND BILL OF MATERIALS

37-006-038

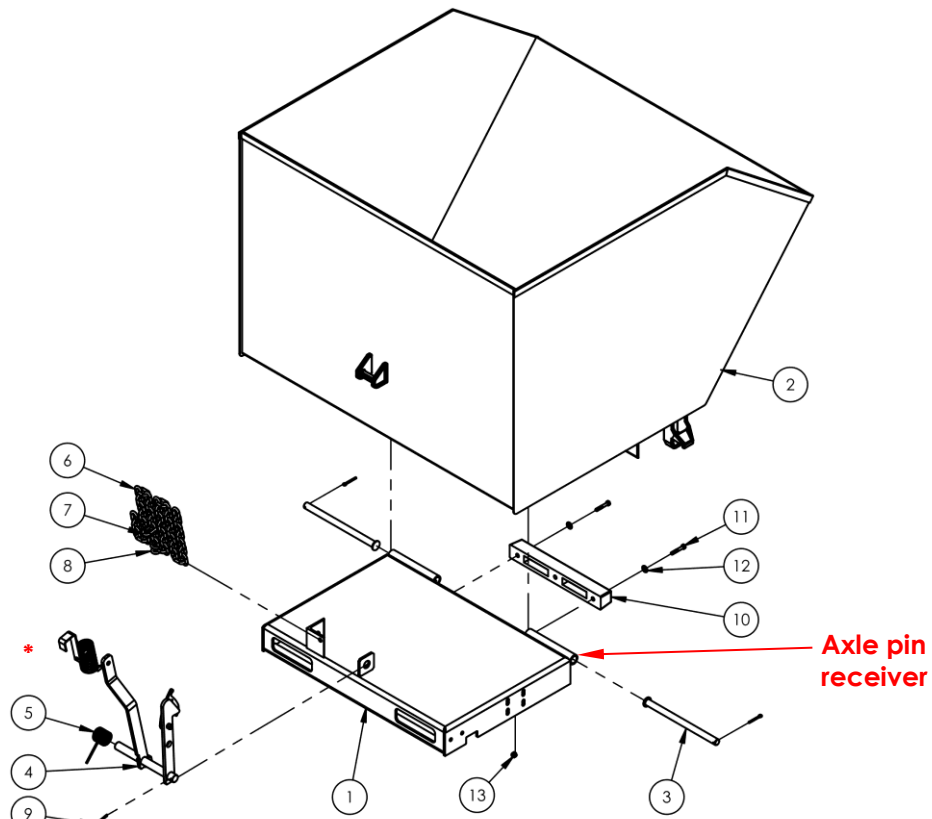

Item	Part no.	Description	Qty.
1	37-514-083	WELDMENT, FRAME, BASE	1
2	37-545-035	WELDMENT, CHUTE H-150-LD	1
	37-545-009	H-150-MD	1
	37-545-049	H-150-HD	1
3	37-112-045	PIN, HINGE AXLE	2
4	37-537-021	WELDMENT, LOCK, RELEASE LEVER ASSEMBLY	1
5	37-146-005	SPRING,TORSION,HOPPER RELEASE	1
6	09-145-018	CHAIN, 5/16" x 56" LG	1
7	99-145-053	5/16" QUICK LINK	1
8	99-145-084	LAP LINK, 5/16" X 1 1/2"	1
9	65127	COTTER PIN Z PLATED, 3/16 x 2	3
10	29-048-061	BUMPER, RUBBER	1
11	11061	HHCS #2 Z PLATED, GRADE A, Ø 5/16 - 18 x 2" LG	2
12	33006	FLAT WASHER,ZINC PLATED,USS, Ø5/16"	2
13	37021	NYLON INSERT LOCK NUT, GRADE 2, ZINC FINISH, 5/16"-18	2

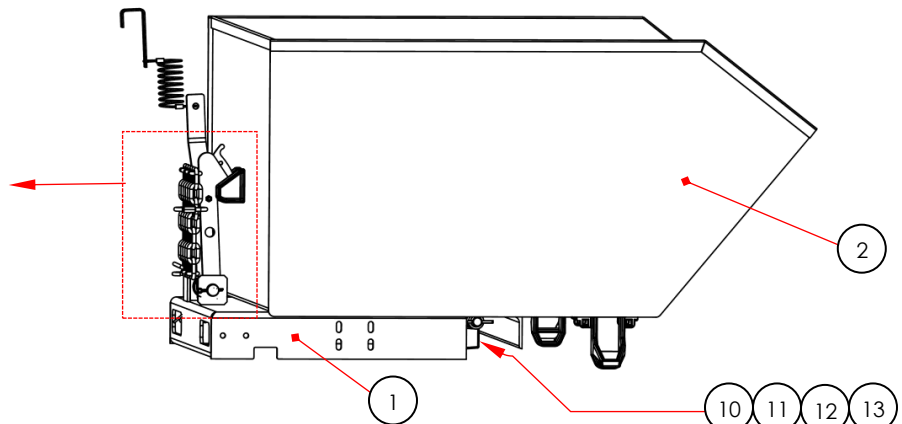
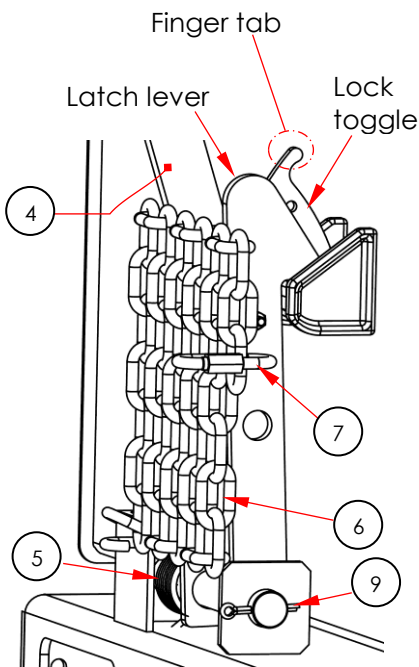

H-200-HD EXPLODED VIEW AND BILL OF MATERIALS

37-006-145

Axle pin receiver

*37-514-044
release handle
and cable
replacement kit
shown on [p. 2](#).

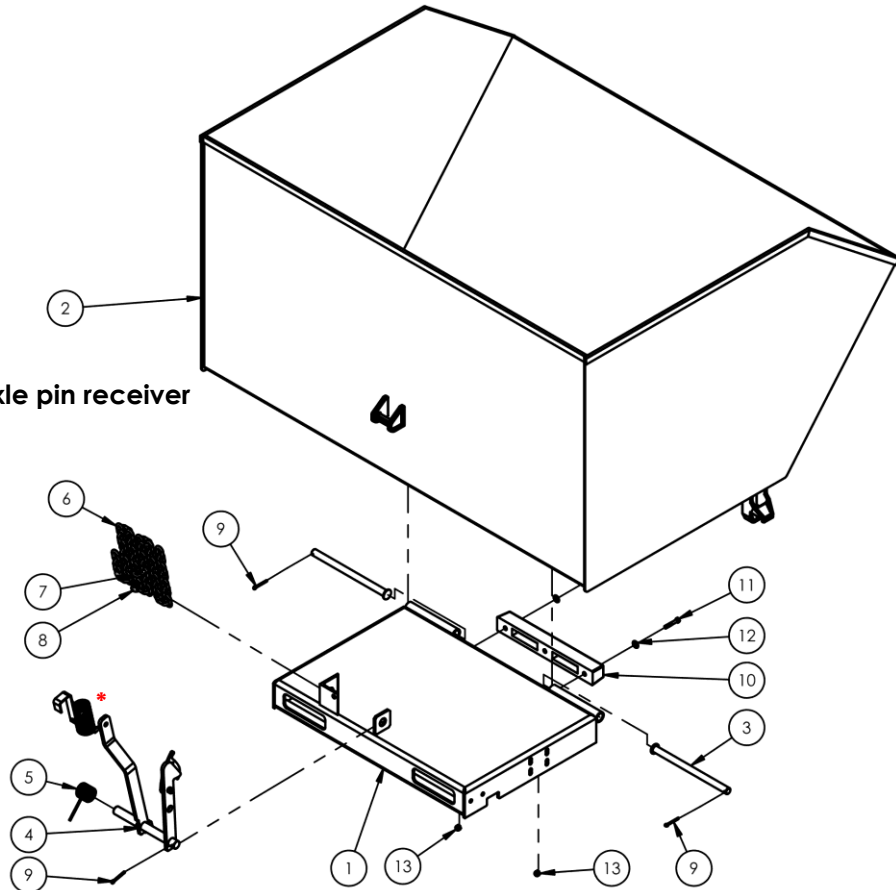

Item	Part no.	Description	Qty.
1	37-514-083	WELDMENT, FRAME, BASE	1
2	37-545-137	WELDMENT, CHUTE	1
3	37-112-045	PIN, HINGE AXLE	2
4	37-537-021	WELDMENT, LOCK, RELEASE LEVER ASSEMBLY	1
5	37-146-005	SPRING,TORSION,HOPPER RELEASE	1
6	09-145-018	CHAIN, 5/16" x 56" LG	1
7	99-145-053	5/16" QUICK LINK	1
8	99-145-084	LAP LINK, 5/16" X 1 1/2"	1
9	65127	COTTER PIN Z PLATED, 3/16 x 2	3
10	29-048-061	BUMPER, RUBBER	1
11	11061	HHCS #2 Z PLATED, GRADE A, Ø 5/16 - 18 x 2" LG	2
12	33006	FLAT WASHER,ZINC PLATED,USS, Ø5/16"	2
13	37021	NYLON INSERT LOCK NUT, GRADE 2, ZINC FINISH, 5/16"-18	2

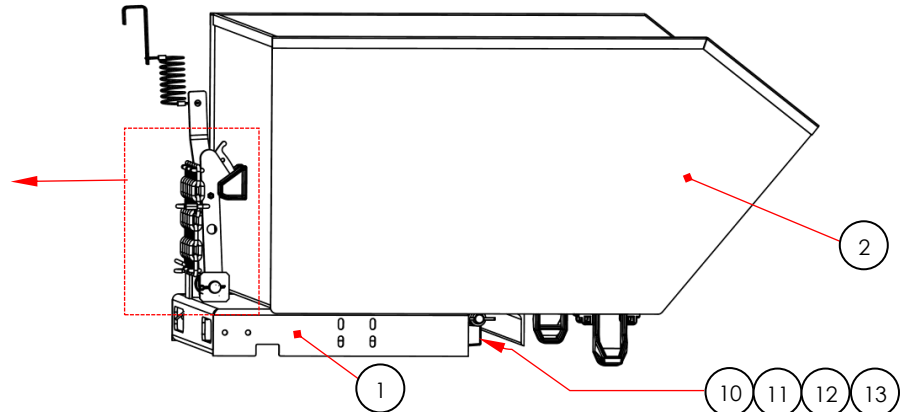
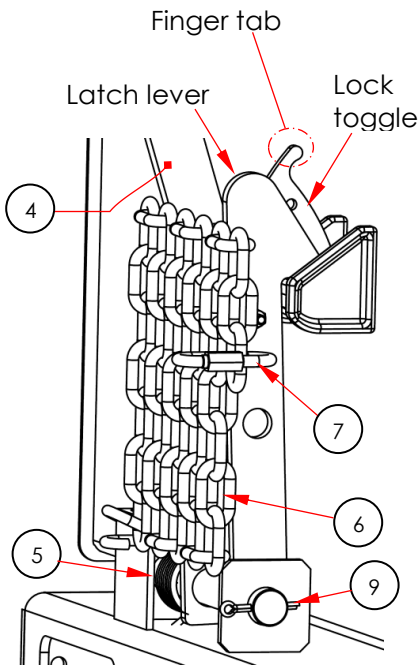

H-BD-L (BUMP-&-DUMP) OPTION EXPLODED VIEW AND BILL OF MATERIALS

37-006-183

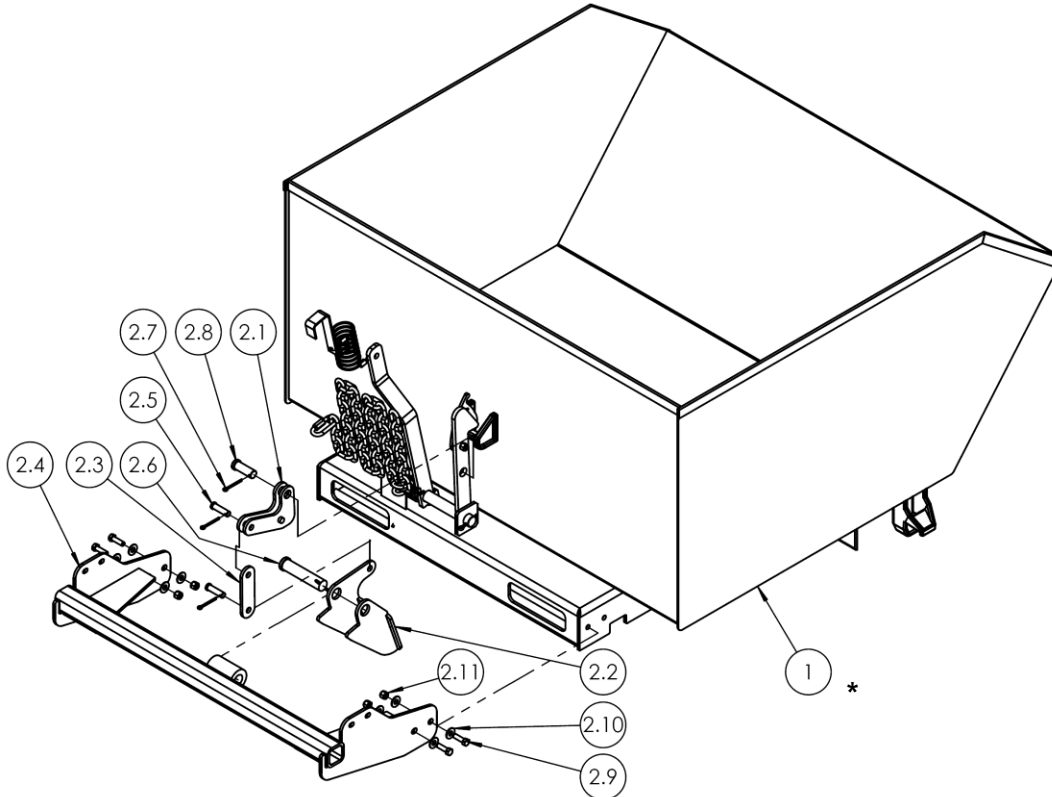

Item	Part no.	Description	Quantity
1*	See p. 4-10	H-HOPPER ASSEMBLY (see appropriate Exploded View on p. 4-10)	1
2	37-537-023	SUB-ASSEMBLY, BUMP AND DUMP	1
2.1	37-516-009	WELDMENT, BRACKET, ADAPTOR	1
2.2	37-537-024	WELDMENT, BUMPER RELEASE	1
2.3	37-016-082	BRACKET, LINKAGE	1
2.4	37-514-119	WELDMENT, FRAME REAR HOOP	1
2.5	21-112-003	PIN, Ø1/2 X 1-15/16 LG RETAINING CLEVIS	2
2.6	33-112-023	PIN, CLEVIS	1
2.7	65107	COTTER PIN, ZINC FINISH, Ø5/32" X 2"	4
2.8	28-112-043	PIN, Ø3/4 X 2" LG CLEVIS, Z-PLATED	1
2.9	11107	HEX BOLT, GRADE A, ZINC FINISH, 3/8"-16 x 1-1/4"	4
2.10	33008	FLAT WASHER, LOW CARBON, USS, ZINC PLATED, 3/8"	8
2.11	37024	NYLON INSERT LOCK NUT, GRADE 2, ZINC FINISH, 3/8"-16	4

INSTALLING THE H-BD-L OPTION

Attach the Bump & Dump option to the base frame weldment using the 3/8" fasteners shown in the Exploded View above. Then, attach the adaptor bracket (37-516-009) to the latch lever with the clevis pin (33-112-023). Insert cotter pin (65107) through the pin hole in the clevis pin. Bend the arms of the cotter pin around the clevis pin.

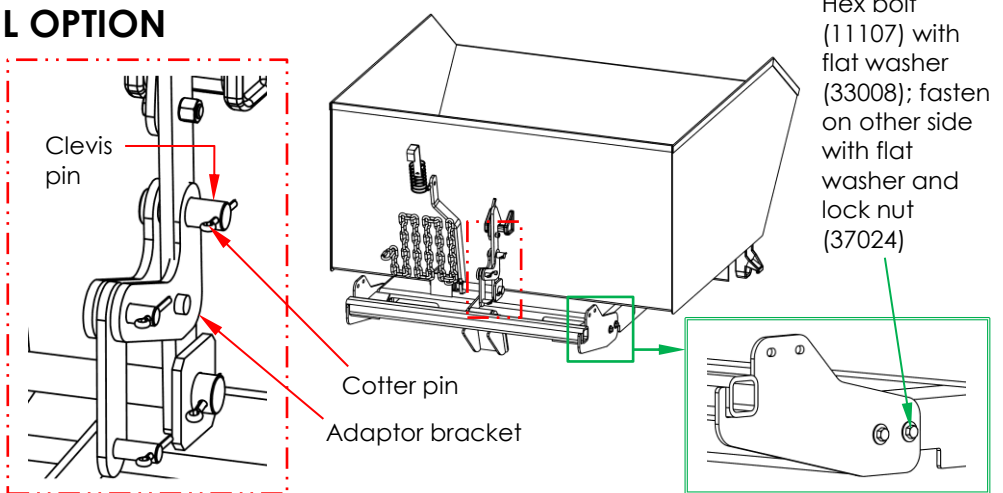

NATIONAL STANDARDS

US OSHA Rule 1910.178 (29 CFR 1910.178; the "Rule") classifies this device as a "front- end attachment" whenever it is mounted on a lift truck. The Rule incorporates American National Standard ANSI/ITSDF B56.1 (the "Standard"). The Standard is published by the Industrial Truck Standards Development Foundation on its website (www.itsdf.org) where it is freely downloadable at <http://www.itsdf.org/cue/b56-standards.html>. **Before putting this device into service**, acquire a copy of the Standard. Apply all relevant parts of Part II: For the User. If instructions provided in this manual apparently conflict with the Standard, then apply the instructions in the Standard. Vestil requests that you immediately share any conflicts you discover with its [TECHNICAL SERVICE](#) personnel. Contact information is provided on the cover page of this manual.

LOADING THE CHUTE

Verify that the hopper chute is securely latched and locked to the base frame before filling it with refuse. Standard H-series hoppers are suitable for use indoors and outdoors and in most industrial and commercial settings. They are designed for use with rider forklift trucks. Put only non-hazardous wastes in the chute.

USING THE CABLE AND HANDLE TO DUMP THE HOPPER

H-series hoppers have a low profile chutes that rotate through a 90° dump angle. To dump the hopper chute using the cable and handle, simply unlock the release lever and pull the release cable.

Step 1: Mount the hopper on the forks of your lift truck. Drive forward until the forks contact the ends of the fork slots. Securely attach the hopper to the fork carriage with the carriage chain by wrapping the free end of the chain around part of the carriage. Then, connect the quick link at the end of the chain to a link in the chain. There should be little to no slack in the chain.

Step 2: Store the handle of the release cable within reach of the forklift operator. For example, the handle could be hooked to the frame of the roll cage.

NOTE: Make sure that there is slack in the cable. If the cable is taut, bumps or sudden stops while driving might cause the chute to be released.

Step 3: Raise the forks and tilt the mast back/towards the cab. Only raise the forks a few inches above the ground. Drive the forklift to the trash dumpster. Pull the finger tab until the latch lock disengages the latch bar. See diagrams included in Step 4 below. Elevate the hopper above the sides of the dumpster.

Step 4: Pull the release cable to release the chute and dump its contents. The chute will pivot about the dump axis. If necessary, tilt the mast forward/away from the cab while pulling the release cable to encourage the chute to dump.

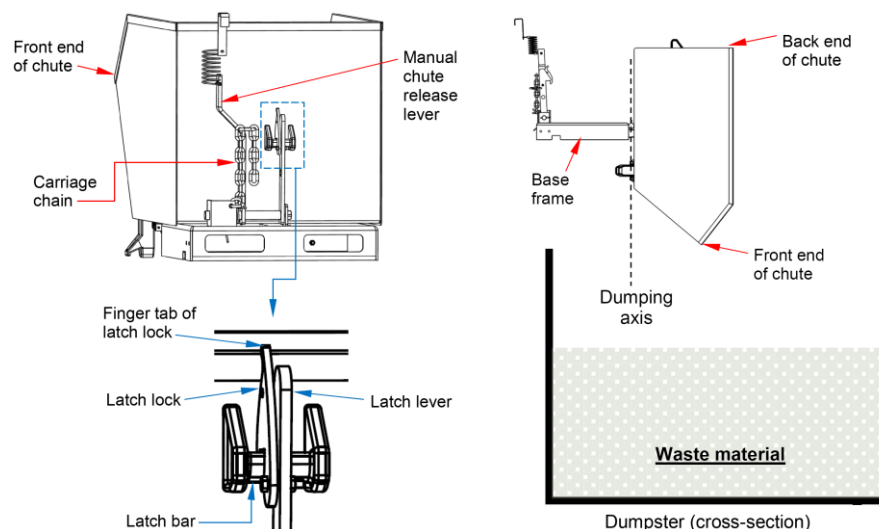
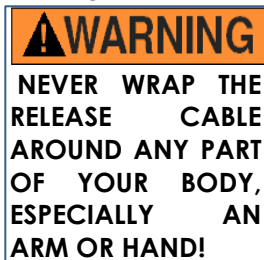

Step 5: Return the chute to the latched position. Tilt the forklift mast toward the cab; then back away from the dumpster. Lower the forks until the hopper contacts the ground; then slowly lower the forks the rest of the way to the ground until the chute latches to the base frame. Confirm that the chute is properly latched by raising the forks. The chute should not rotate. If necessary, lower the forks completely and manually latch the chute to the frame by pressing down on the back of the chute (see "H-series" diagram in Step 4). Alternatively, use the side of the dumpster to pivot the chute back onto the base frame.

Step 6: Lock the latch. Press the latch lock forward until it firmly engages the latch bar.

USING THE BUMP-AND-DUMP OPTION TO DUMP THE HOPPER

Vestil offers kit H-BD-L to equip standard H-series hoppers with a "Bump-&-Dump" capability. To dump the hopper chute, unlock the release lever and either pull the release cable or use the bumper release mechanism.

Step 1: Mount the hopper on the forks of your lift truck. Drive forward until the forks contact the ends of the fork slots. Securely attach the carriage chain to the forklift carriage by wrapping the free end of the chain around part of the carriage. Then, connect the quick link at the end of the chain to a link in the chain. There should be little to no slack in the chain. Unlock the chute release mechanism by pulling the finger tab until the latch lock disengages the latch bar. See diagrams included in Step 4 below.

Step 2: Store the handle of the release cable within reach of the forklift operator. For example, the handle could be hooked to the frame of the roll cage.

NOTE: Make sure that there is slack in the cable. If the cable is taut, bumps or sudden stops while driving might cause the chute to be released.

Step 3: Raise the forks and slightly tilt the mast back/towards the cab. Only raise the forks a few inches above the ground. Drive the forklift to the trash dumpster. Then, elevate the hopper above a side of the dumpster. The dumping axis of the hopper should be within/inside the dumpster.

Step 4: Dump the chute using the bumper release mechanism. Slowly drive forward until the bumper release lever presses against the side of the dumpster. Stop driving forward as soon as the hopper is released.

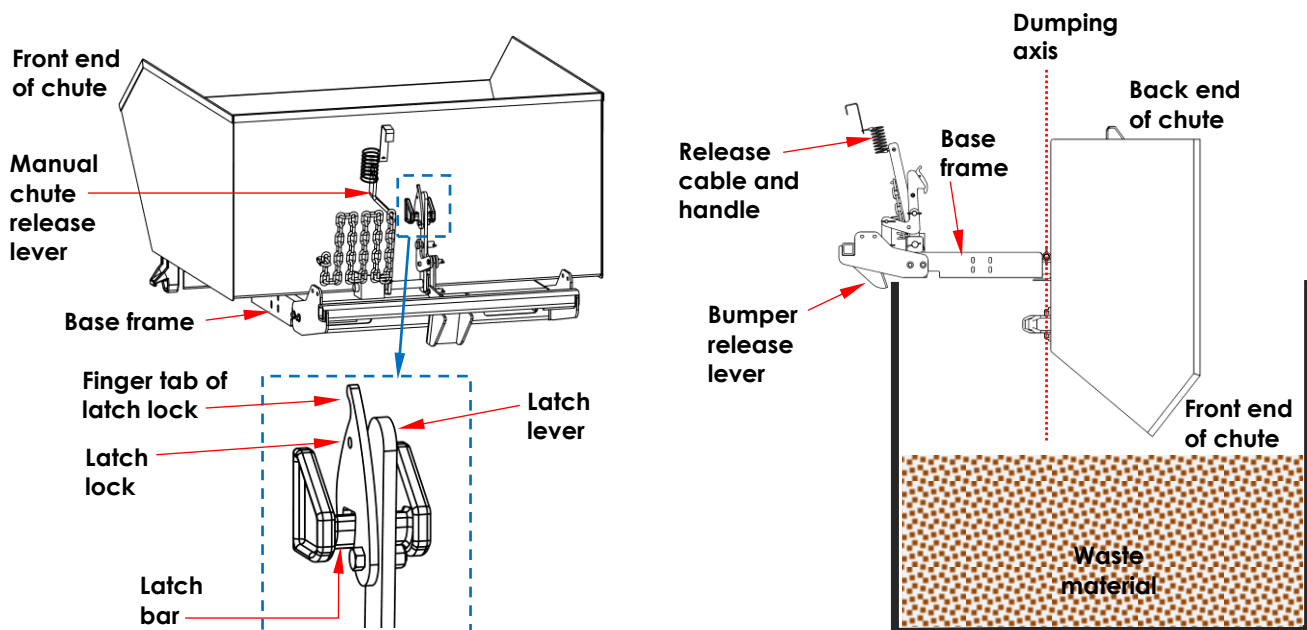

Step 5: Return the chute to the latched position. Tilt the forklift mast toward the cab; then back away from the dumpster. Lower the forks until the hopper contacts the ground; then slowly lower the forks the rest of the way to the ground until the chute latches to the base frame. Confirm that the chute is properly latched by raising the forks. The chute should not rotate. If necessary, lower the forks completely and manually latch the chute to the frame by pressing down on the back of the chute. Alternatively, use the side of the dumpster to pivot the chute back onto the base frame.

Step 6: Lock the latch by pressing the latch lock over the top of the latch bar.

STACKING HOPPERS

H-series hoppers are designed to stack on top of each other. Notches in the base and rim grooves in specially designed cast feet of one hopper engage the rim of the hopper supporting it as shown in the diagram to the right.

Hoppers of identical width can be stacked together, i.e. H-25 and H-50 series hoppers stack together. H-100 and H-150 series hoppers also stack together. Always unload hoppers before stacking them and NEVER create stacks of more than 3 hoppers. The bottom hopper must not be equipped with casters.

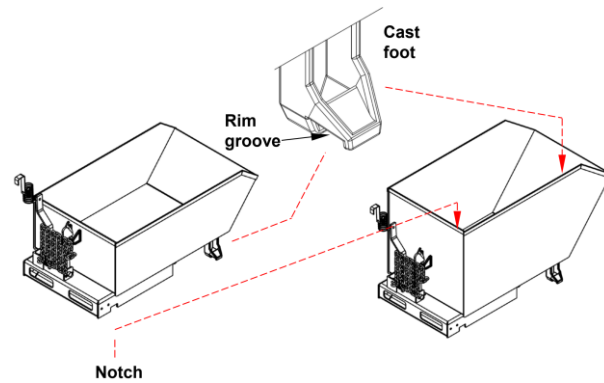

⚠️WARNING DO NOT move stacked hoppers! Only move one hopper at a time by properly mounting it to your forklift as described in Step 1 on p. 12. **All hoppers must be empty whenever they are stacked.**

RECORD OF SATISFACTORY CONDITION (THE “RECORD”)

Before using this hopper for the first time, create a record OF its appearance and features. Include descriptions of the chute, feet, base, carriage chain and quick link, pivot points and pivot point hardware, and the chute release mechanism. Release the chute. Describe how the unit looks and sounds as the chute rotates. Also describe the force necessary to release the chute using both the manual release lever and the cable. Secure the chute to the base and describe how the latch mechanism works. Thoroughly photograph the unit including all labels. Collate all writings and photographs into a single file. This file is a record of the unit in satisfactory condition. **Compare your results of all inspections to this record to determine if the unit is still in satisfactory condition.** Restore the hopper to satisfactory condition BEFORE using it again. Cosmetic changes, like damaged surface coating (paint or powdercoat) are not changes from satisfactory condition. However, touchup paint should be applied as soon as damage occurs to prevent rusting.

INSPECTIONS & MAINTENANCE

Inspections and repairs should only be performed by qualified persons. Compare the results of each inspection to the [RECORD OF SATISFACTORY CONDITION](#) (the “RECORD”). Do not use the hopper unless all parts are in satisfactory condition. Replace parts that are not in satisfactory condition before using the hopper again. **DON'T GUESS! If you have any questions about the condition of your hopper, speak with [TECHNICAL SERVICE personnel](#).** The phone number is provided on the cover page of this manual. **Never make temporary repairs of damaged or missing parts.** Only use manufacturer-approved replacement parts.

Make a dated record of each inspection that includes observations and descriptions of repairs and/or replacements installed.

- 1) Pivot points: Look for excessive wear, warps, damage to pivot pins, cotter pins, or pin receivers.
- 2) Hopper chute and base frame: Examine the structure for damage, deformations, and corroded or excessively rusted areas.
- 3) Hardware (bolts, nuts, pins, cotter pins, retaining rings): inspect hardware for looseness and severe wear. Tighten loose connections and replace all damaged hardware.
- 4) Casters (if hopper is equipped with caster kit): check for looseness, excessive wear, or damage to the casters, caster bearings, mounting brackets, and hardware.
- 5) Release mechanism: Torsion spring should cause the latch lever to automatically recoil. The lever should firmly engage the release lock bar. Check the cable for frayed, thinned, or bird-caged regions. [Replacement kit 37-154-044](#) (see [p. 2](#)) includes a handle, cable, and 2 wire clamps (1/4”). To install a replacement handle & cable kit, loosen the nuts of both wire clamps & feed the free end of the cable through the clamps. Insert the end of the cable through the hole in the manual chute release lever. See [p. 11](#). Feed the cable back through the clamps & then tighten all 4 nuts.
- 6) Moving parts: listen for unusual noises and watch for irregular movement. Remove dirt and debris from areas that could affect the hopper’s dumping motion.
- 7) Carriage chain: examine the carriage chain, its point of attachment to the base frame, and the quick links for damage.
- 8) Labels: all labels must be firmly affixed in the locations shown in the [LABELING DIAGRAM](#) on [p. 14](#).

LABELING DIAGRAM

The unit should be labeled as shown in the diagram. However, label content and location are subject to change so your product might not be labeled exactly as shown. Thoroughly photograph the unit when you first receive it as discussed in the *Record of Satisfactory Condition* section on p. 13. Make sure that your record includes a photograph of each label. Replace all labels that are, or later become, damaged, missing, or not easily readable (e.g. faded). To order replacement labels, contact the *Technical Service & Parts Department* online at <https://www.vestil.com/page-parts-request.php>. Alternatively, you may call (260) 665-7586 and ask the operator to connect you to the *Parts Department*.

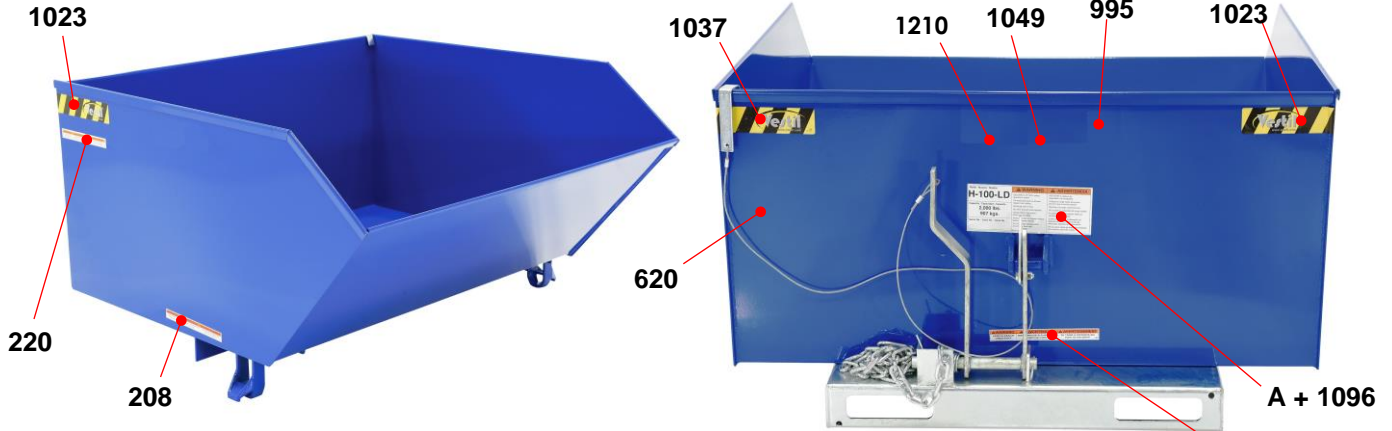

Label 1023



Label 1037



Label 995

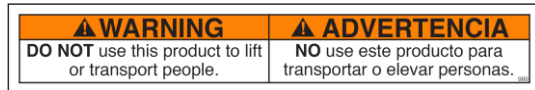

Label 1049

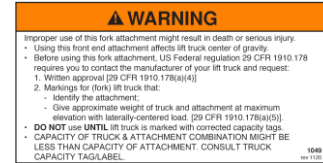

Label 1210

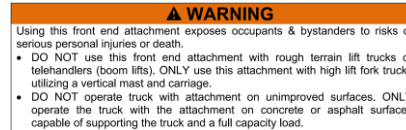

Label 620: Left side in line with release handle



A: Model specific label (627 shown); See table.

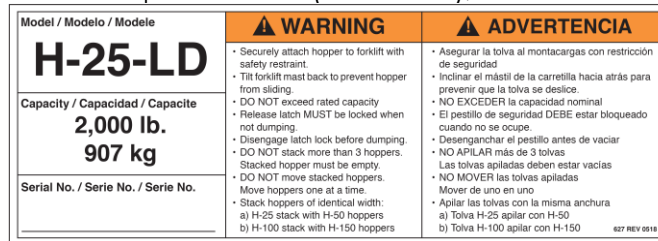

*Label 1096

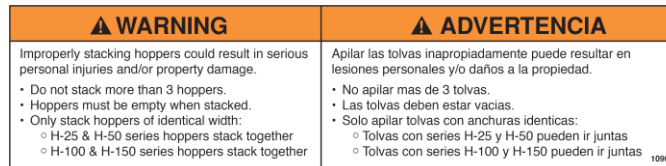

* Not necessary if model specific label includes 1096 wording.

Model	Label
H-25-LD	627
H-25-MD	549
H-25-HD	538
H-33-LD	1146
H-33-MD	1147
H-33-HD	1148
H-50-LD	629
H-50-MD	535
H-50-HD	628
H-75-LD	1150
H-75-MD	1151
H-75-HD	1152
H-100-LD	533
H-100-MD	536
H-100-HD	539
H-150-LD	534
H-150-MD	537
H-150-HD	590
H-200-HD	1093

Label 208



Label 220



LIMITED WARRANTY



Vestil Manufacturing Company ("Vestil") warrants this product to be free of defects in material and workmanship during the warranty period. Our warranty obligation is to provide a replacement for a defective, original part covered by the warranty after we receive a proper request from the Warrantee (you) for warranty service.

Who may request service?

Only a warrantee may request service. You are a warrantee if you purchased the product from Vestil or from an authorized distributor AND Vestil has been fully paid.

Definition of "original part"?

An original part is a part used to make the product as shipped to the Warrantee.

What is a "proper request"?

A request for warranty service is proper if Vestil receives: 1) a photocopy of the Customer Invoice that displays the shipping date; AND 2) a written request for warranty service including your name and phone number. Send requests by one of the following methods:

<u>US Mail</u>	<u>Fax</u>	<u>Email</u>
Vestil Manufacturing Company	(260) 665-1339	info@vestil.com
2999 North Wayne Street, PO Box 507	<u>Phone</u>	Enter "Warranty service request" in subject field.
Angola, IN 46703	(260) 665-7586	

In the written request, list the parts believed to be defective and include the address where replacements should be delivered. After Vestil receives your request for warranty service, an authorized representative will contact you to determine whether your claim is covered by the warranty. Before providing warranty service, Vestil will require you to send the entire product, or just the defective part (or parts), to its facility in Angola, IN.

What is covered under the warranty?

The warranty covers defects in the following original, dynamic parts: motors, hydraulic pumps, electronic controllers, switches, and cylinders. It also covers defects in original parts that wear under normal usage conditions ("wearing parts"), such as bearings, hoses, wheels, seals, brushes, and batteries.

How long is the warranty period?

The warranty period for original dynamic components is 1 year. For wearing parts, the warranty period is 90 days. Both warranty periods begin on the date Vestil ships the product to the Warrantee. If the product was purchased from an authorized distributor, the periods begin when the distributor ships the product. Vestil may, at its sole discretion, extend a warranty period for products shipped from authorized distributors by up to 30 days to account for shipping time.

If a defective part is covered by the warranty, what will Vestil do to correct the problem?

Vestil will provide an appropriate replacement for any covered part. An authorized representative of Vestil will contact you to discuss your claim.

What is not covered by the warranty?

The Warrantee (you) are responsible for paying labor costs and freight costs to return the product to Vestil for warranty service.

Events that automatically void the Limited Warranty.

- Misuse;
- Negligent assembly, installation, operation or repair;
- Installation/use in corrosive environments;
- Inadequate or improper maintenance;
- Damage sustained during shipping;
- Collisions or other accidents that damage the product;
- Unauthorized modifications: Do not modify the product IN ANY WAY without first receiving written authorization from Vestil.

Do any other warranties apply to the product?

Vestil Manufacturing Co. makes no other express warranties. All implied warranties are disclaimed to the extent allowed by law. Any implied warranty not disclaimed is limited in scope to the terms of this Limited Warranty. Vestil makes no warranty or representation that this product complies with any state or local design, performance, or safety code or standard. Noncompliance with any such code or standard is not a defect in material or workmanship.