

# Assembly Instructions

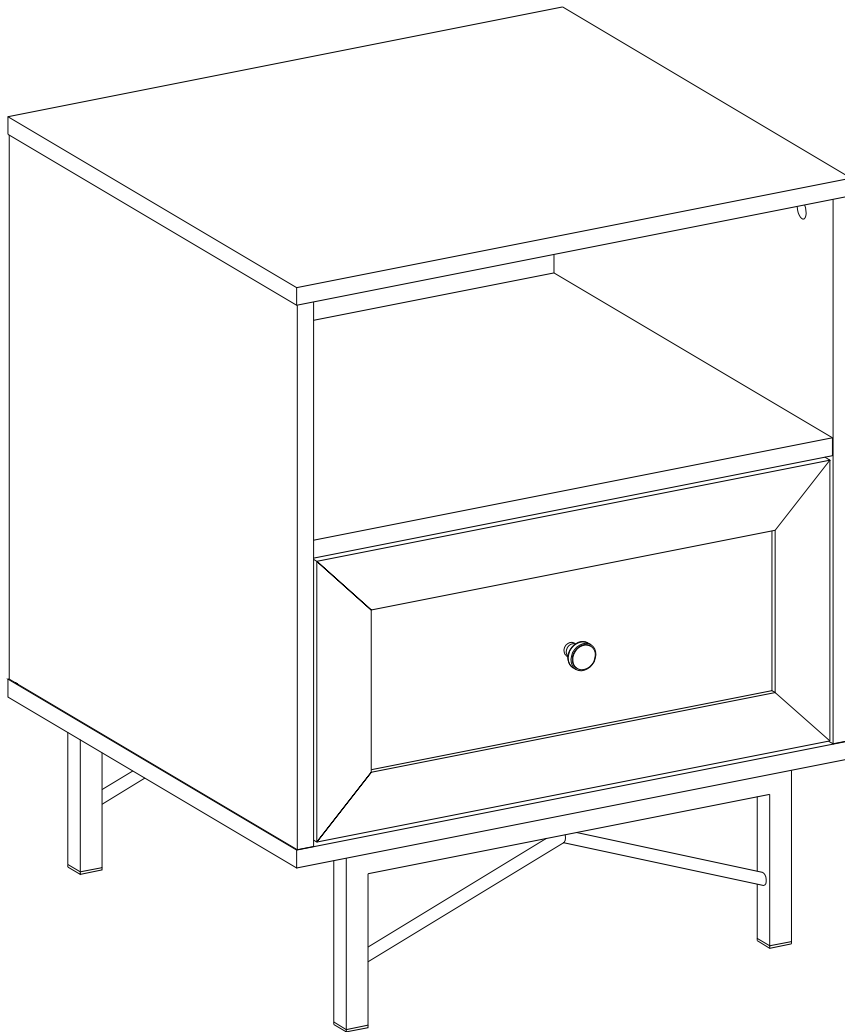

*Please visit our website for the most current instructions, assembly tips, report damage, or request parts.*

# General Assembly Guidelines

- I. Ensure that all parts and hardware are available before beginning assembly.
- II. Follow each step carefully to ensure the proper assembly of this product.
- III. Two people are recommended for ease in the assembly of this product.
- IV. The three main types of hardware used to assemble this product are: wood dowels, screws and bolts.
- V. The provided glue is to secure wood dowels in place. When first inserting dowels, locate the appropriate hole for the dowel, place a small amount of glue in the hole and insert the dowel. Wipe away excess glue immediately.

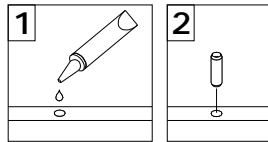

In future assembly steps when dowels are necessary to attach assembly parts together, place a small amount of glue on the end of the dowel before attaching parts together. Wipe away excess glue immediately.

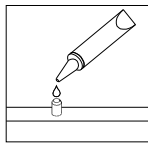

- VI. A Phillips head screwdriver is required for the assembly of this product .

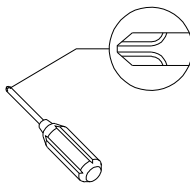

- VII. Power tools should not be used to assemble this product.

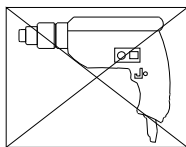





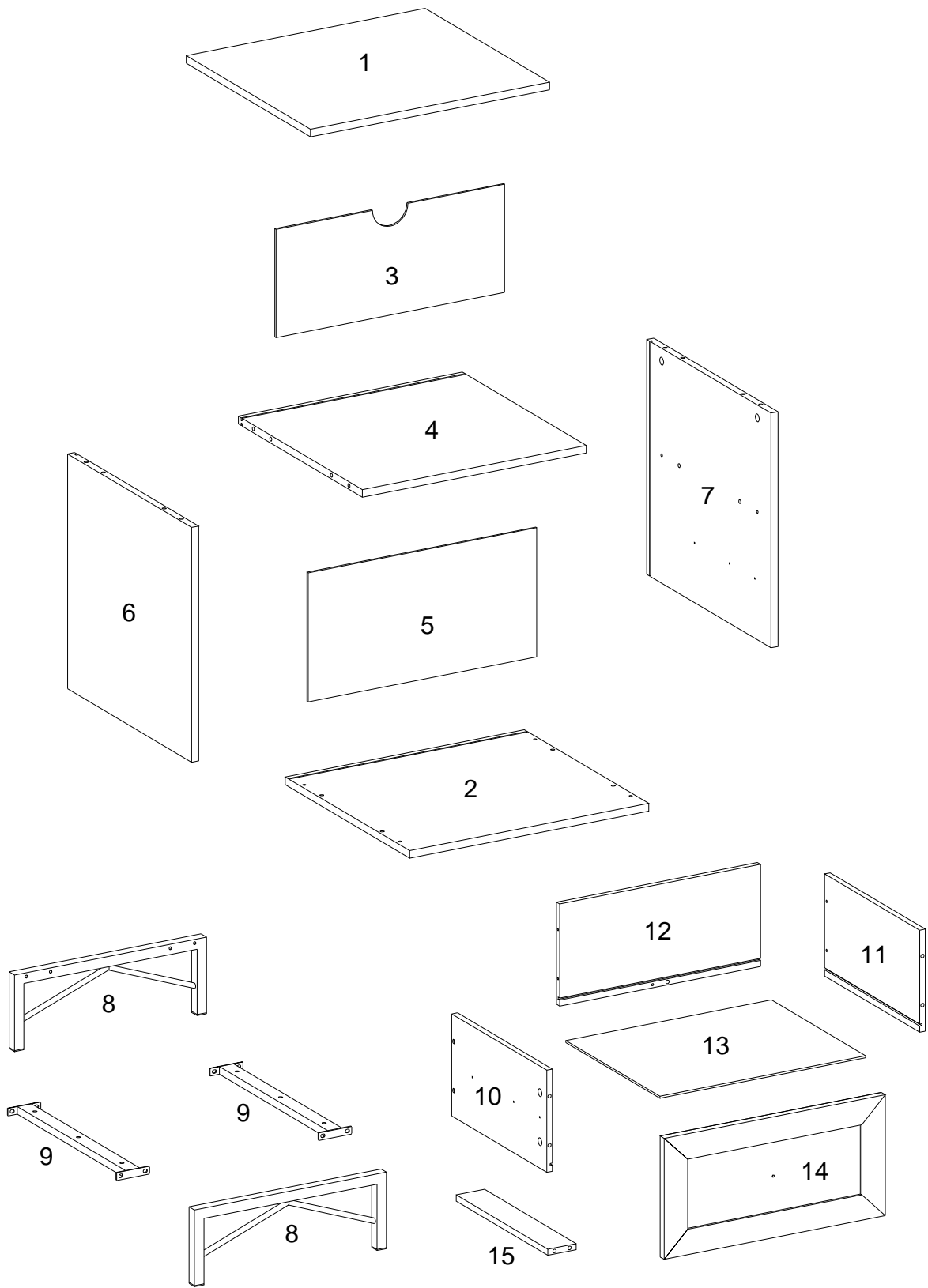









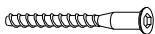

- VIII. Drill may be needed for securing product to wall.

# Parts List

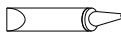

# Hardware List

A		Ø8x30mm	Wooden dowel	12	pcs
B		Ø6x35mm	Cam bolt	13	pcs
C		Ø15x11mm	Cam lock	8	pcs
D		Ø15x9mm	Cam lock	5	pcs
E		Ø30mm	Sticker	13	pcs
F		Ø3x12mm	Screw	12	pcs
G		Ø6x50mm	Screw	4	pcs
H		Ø6x12mm	Bolt	8	pcs
J		Ø6x25mm	Bolt	6	pcs
K		M 4	Hex key	1	pc
L			Handle	1	pc
M		Ø4x10mm	Handle Bolt	1	pc
N		Ø3x17mm	Screw	8	pcs
P			Plastic wedge	8	pcs
Q		Ø4x38mm	Screw	5	pcs
R		Ø6x30mm	Wooden dowel	2	pcs
S		12"	Drawer slider	1	set
T			Glue tube	1	pc

\* Note: This piece comes preassembled for shipping purposes and must be disassembled to complete the desk assembly.

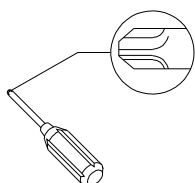

Philips head screwdriver required for assembly  
(not included)

*The hardware quantities listed above are required for proper assembly.  
Some extra hardware may also have been included.*

# Step 1

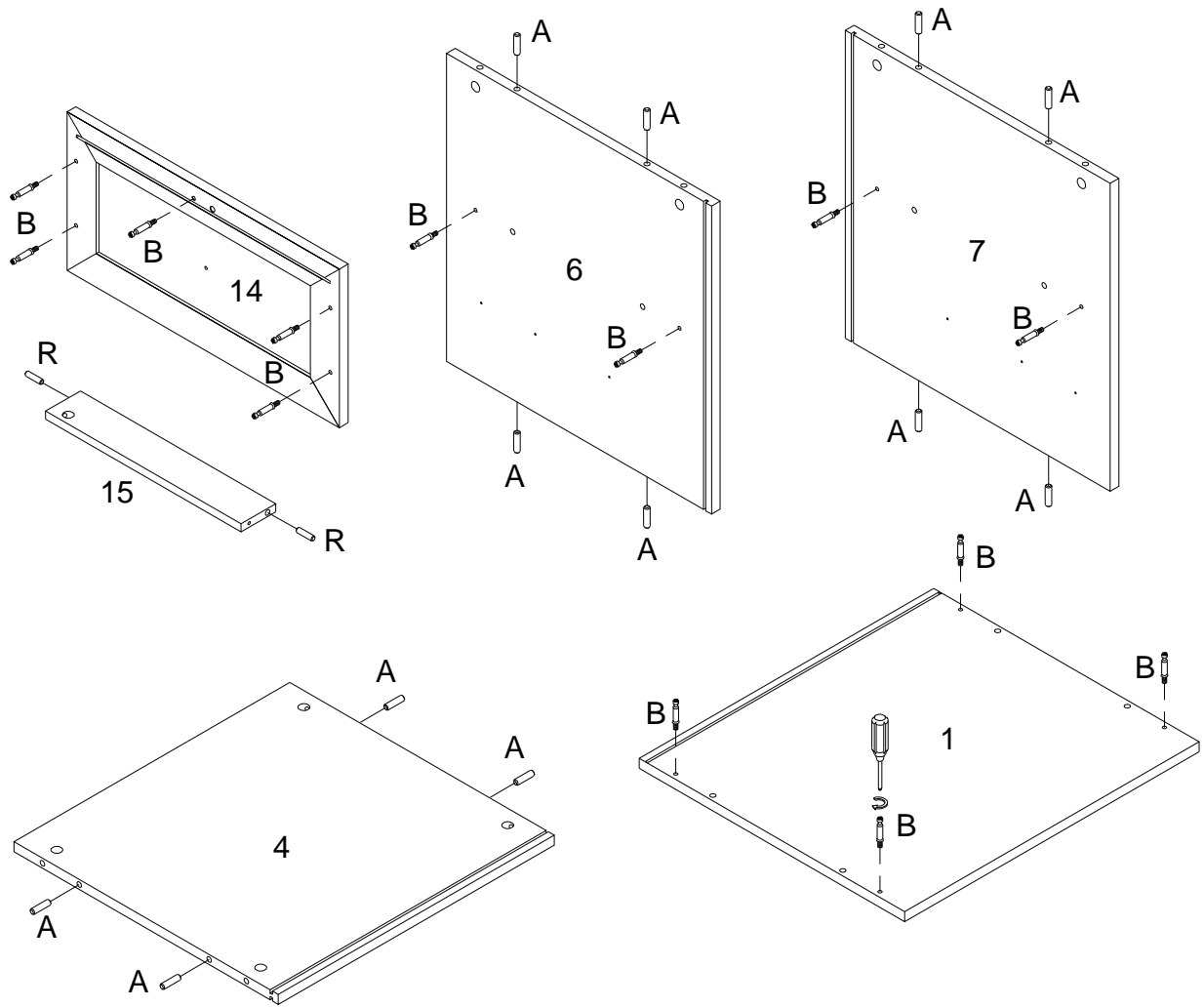

Insert wooden dowel (A) into parts (4,6,7) and wooden dowel (R) into part (15) ,then secure cam bolt (B) into parts (1,6,7,14) with Philips head screwdriver as per diagram.

# Step 2

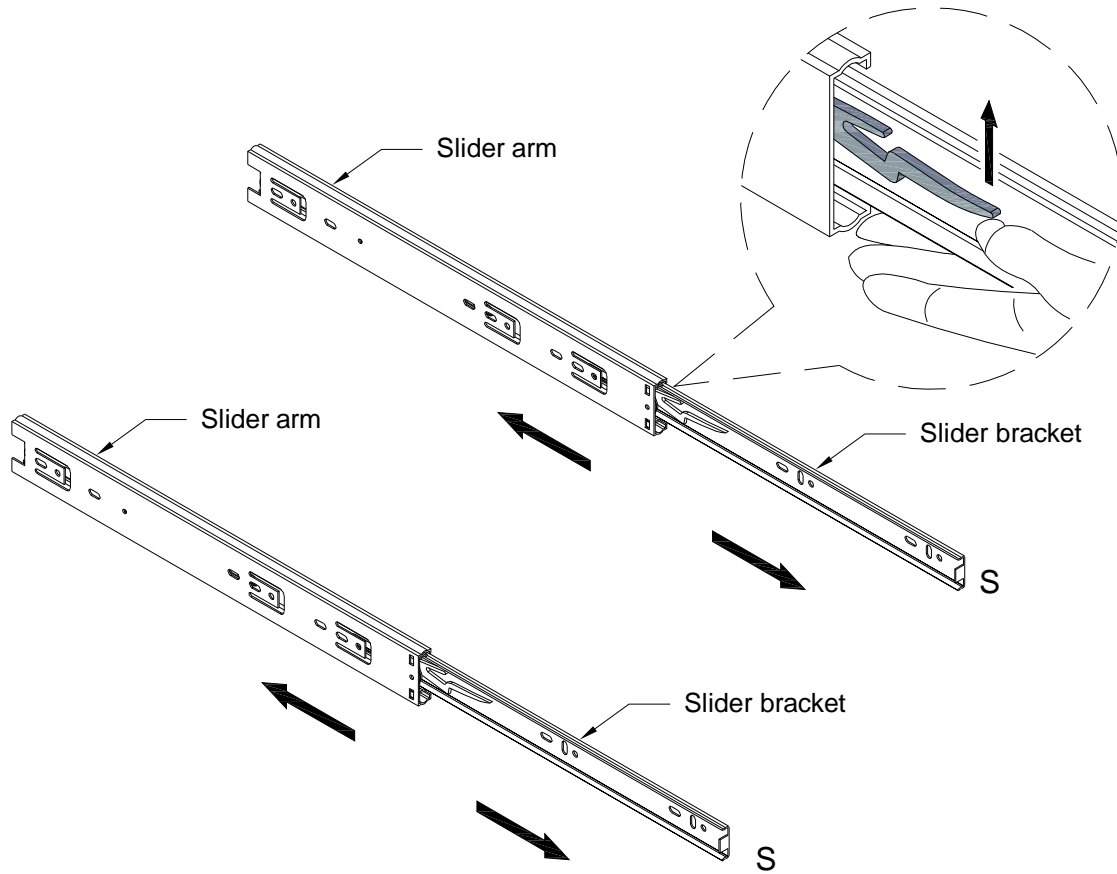

Pick up the slider arm (S) and separate the slide runner for the following Steps. Extend the slide runner all the way forward, press the plastic release lever of the slider arm up and pull the slide runner complete out .

# Step 3

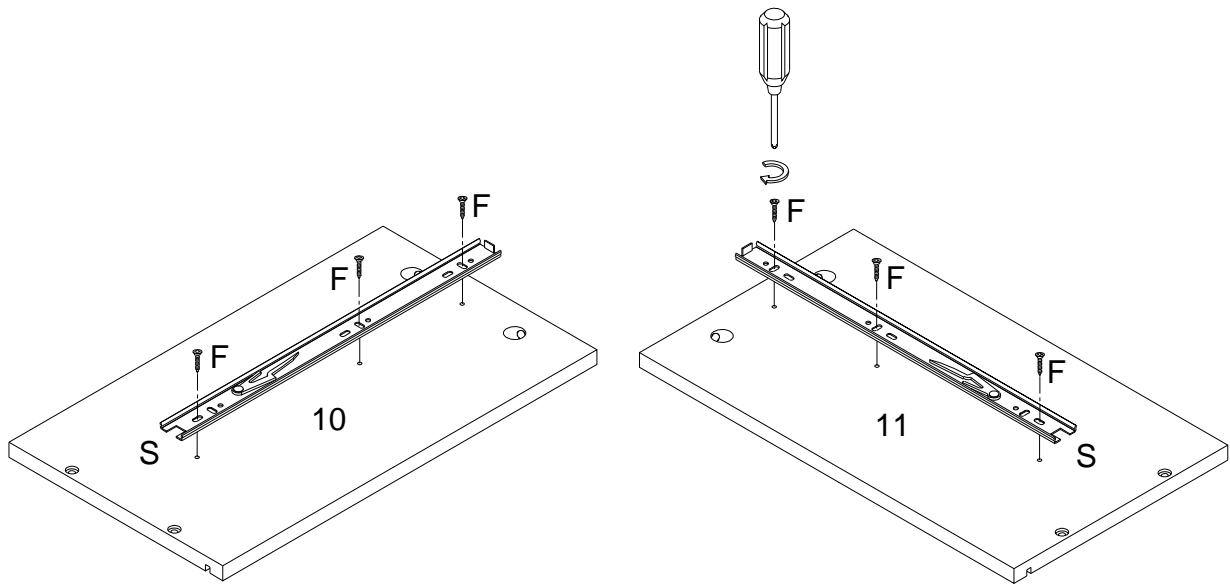

Using screw (F) attach drawer slider (S) to parts (10,11) with Philips head screwdriver as per diagram.

# Step 4

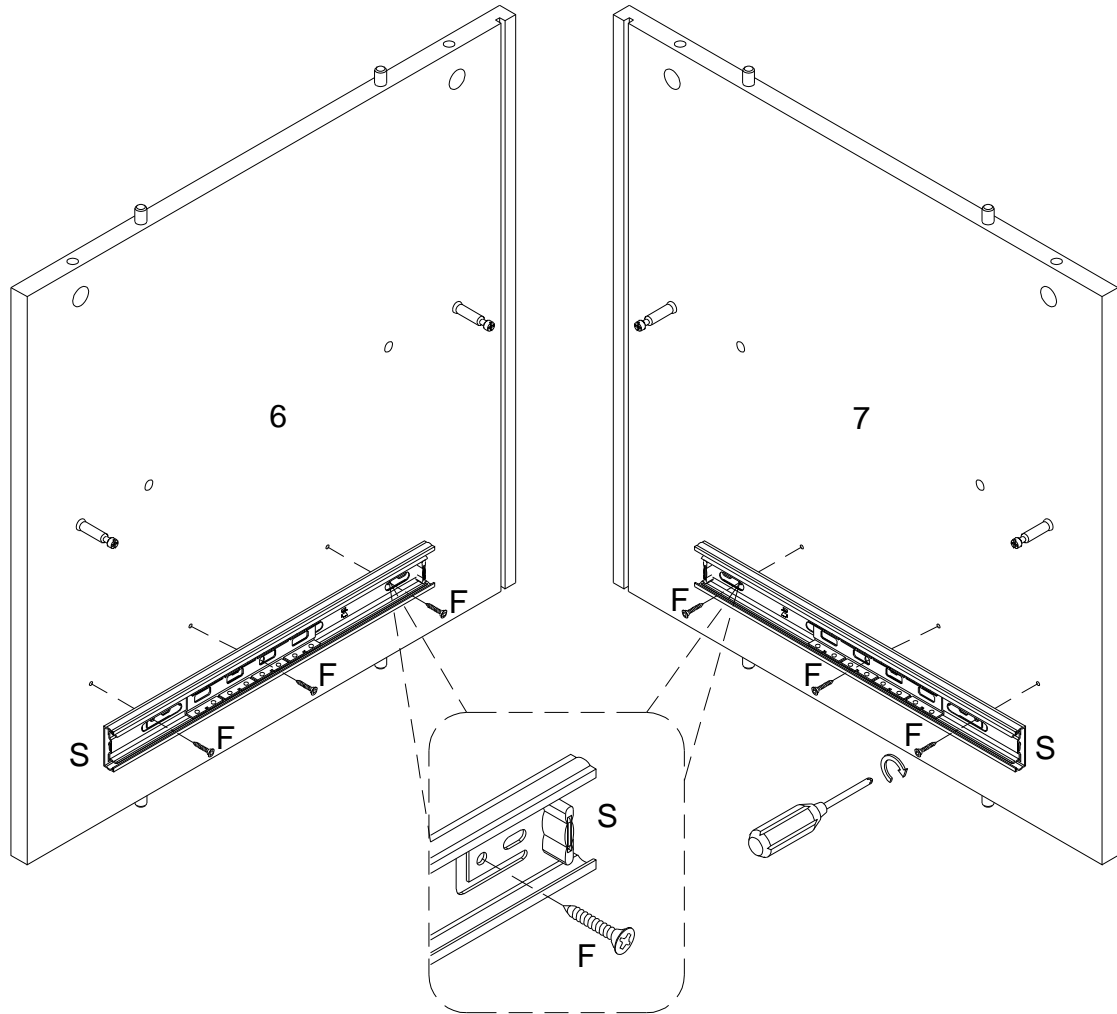

Using screw (F) attach drawer slider (S) to parts (6,7) with Philips head screwdriver as per diagram.

# Step 5

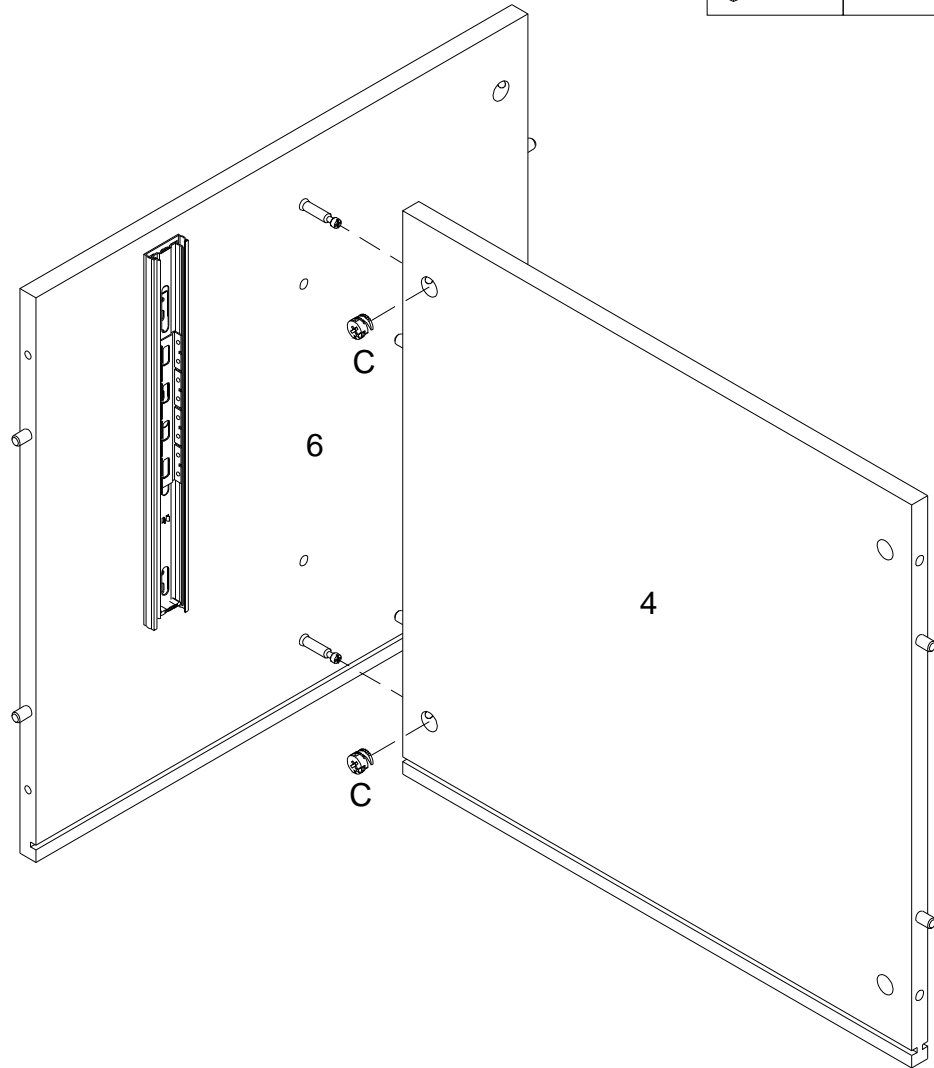
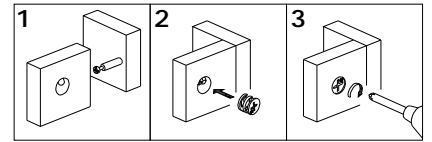

Using Cam lock(C) secure part (4) to part (6) with Philips head screwdriver as per diagram.

# Step 6

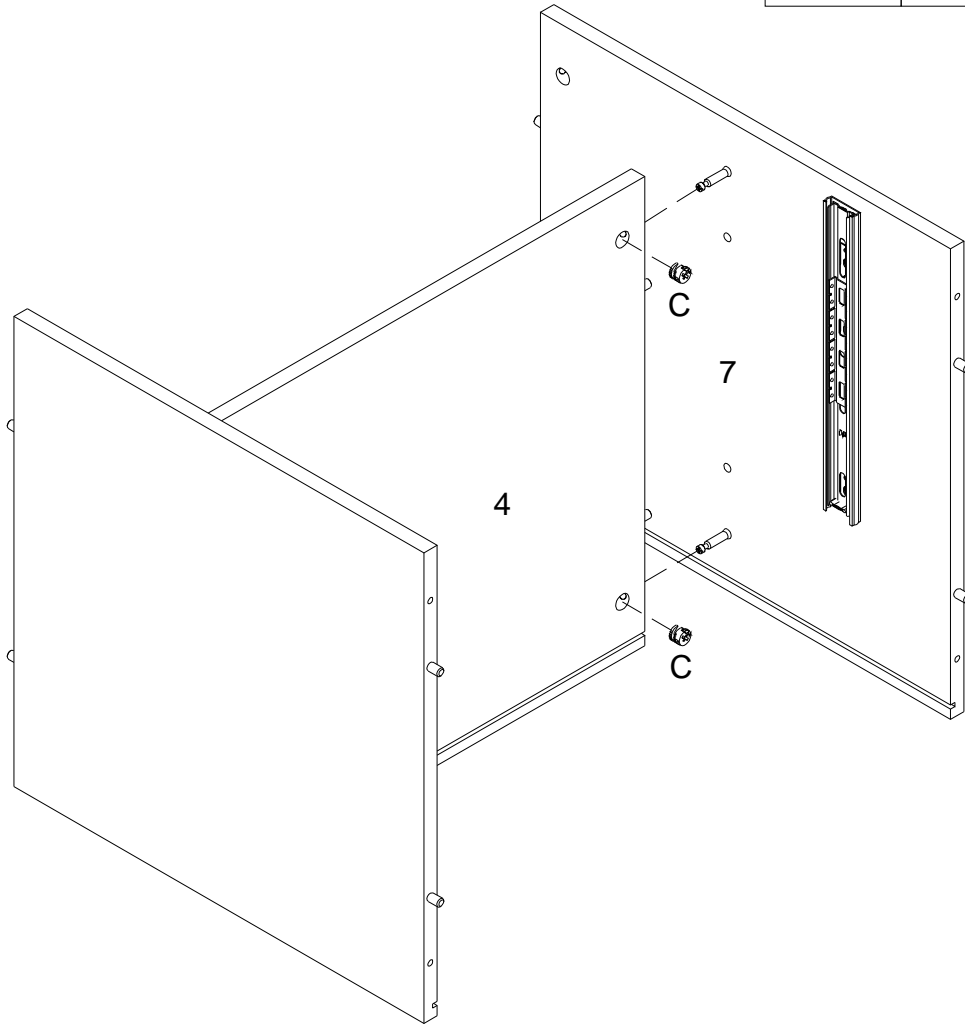
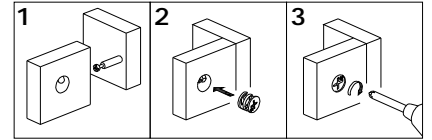

Using Cam lock(C) secure part (4) to part (7) with Philips head screwdriver as per diagram.

# Step 7

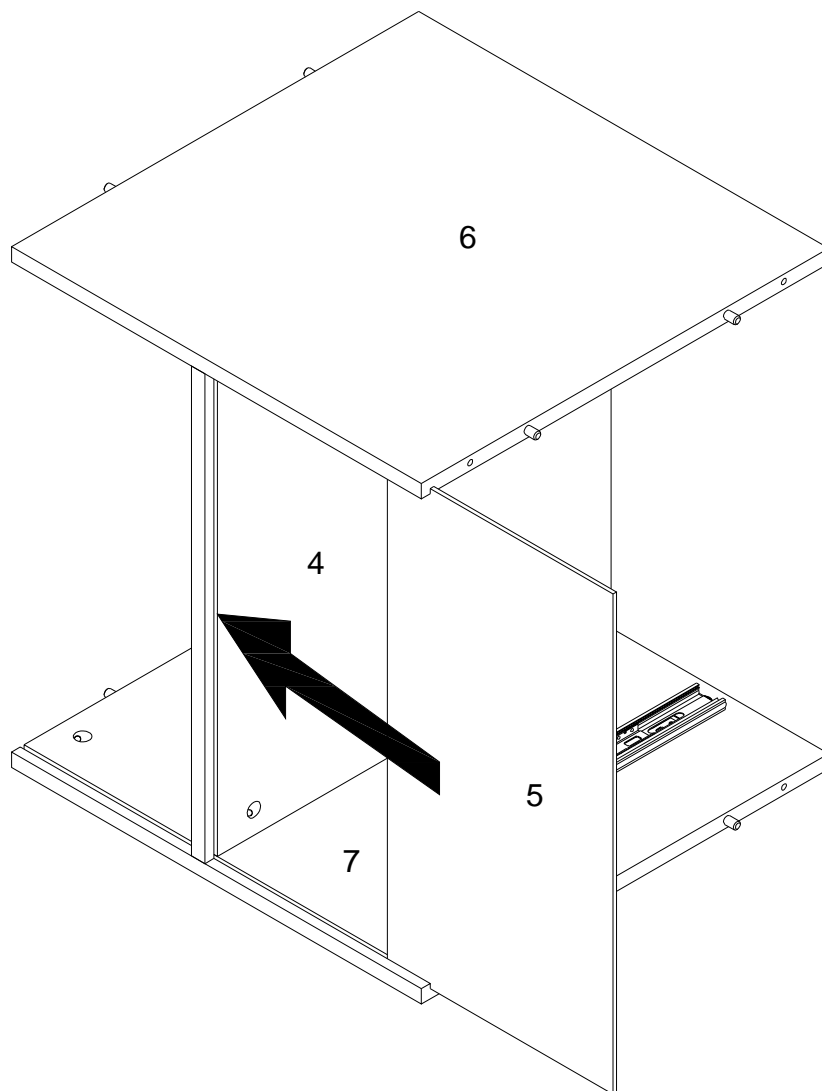

Put part (5) as per diagram.

# Step 8

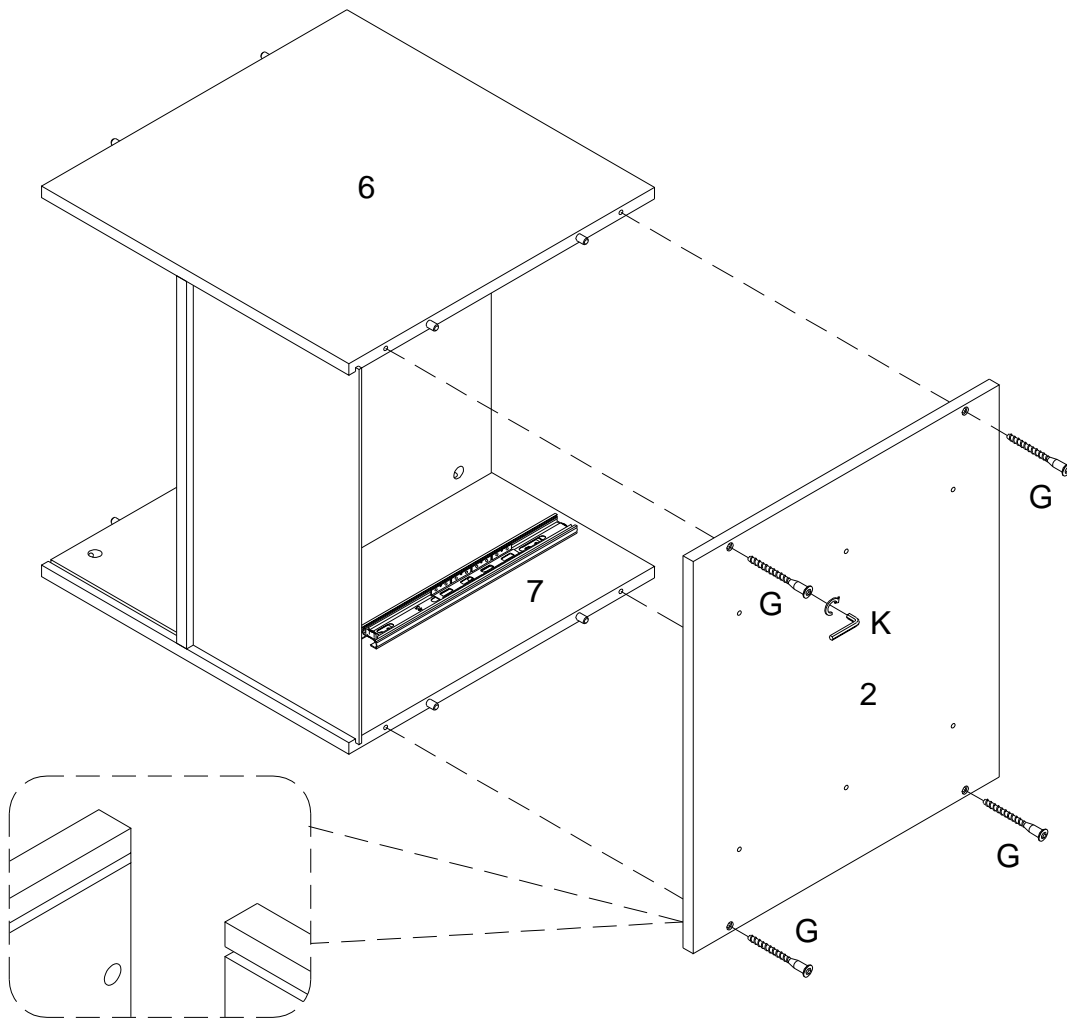

Using screw (G) attach part (2) to parts (6,7) with Hex key (K) as per diagram.

# Step 9

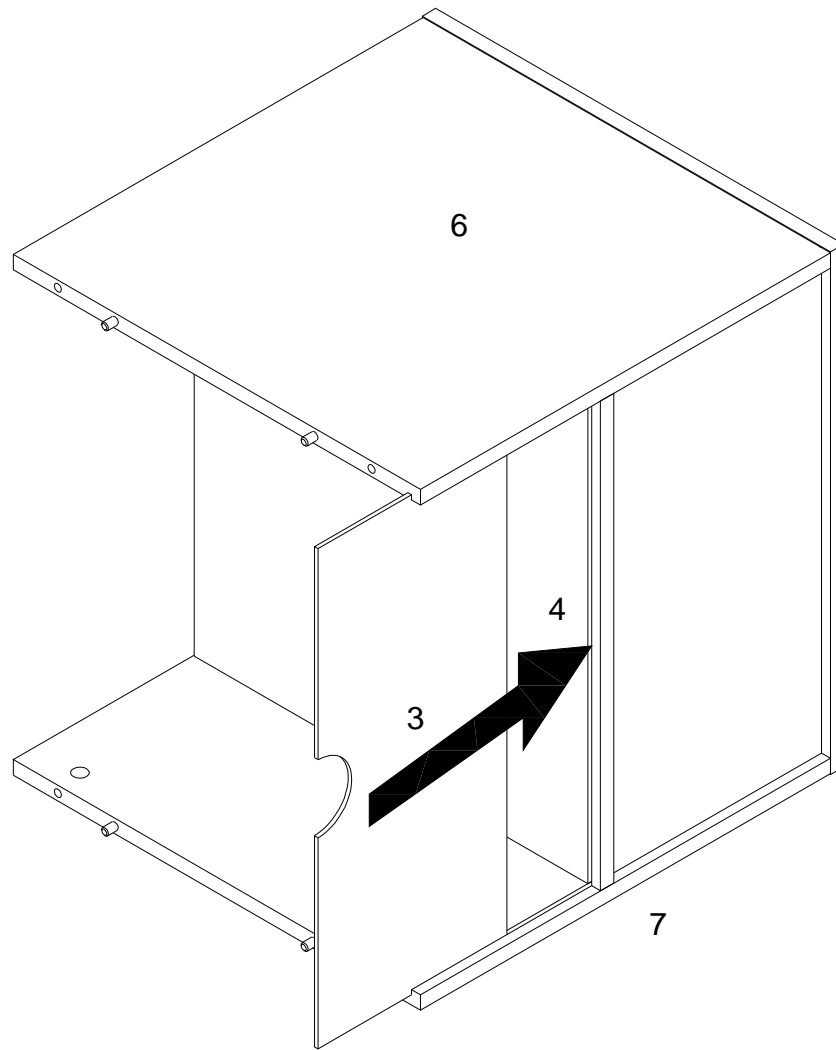

Put part (3) as per diagram.

# Step 10

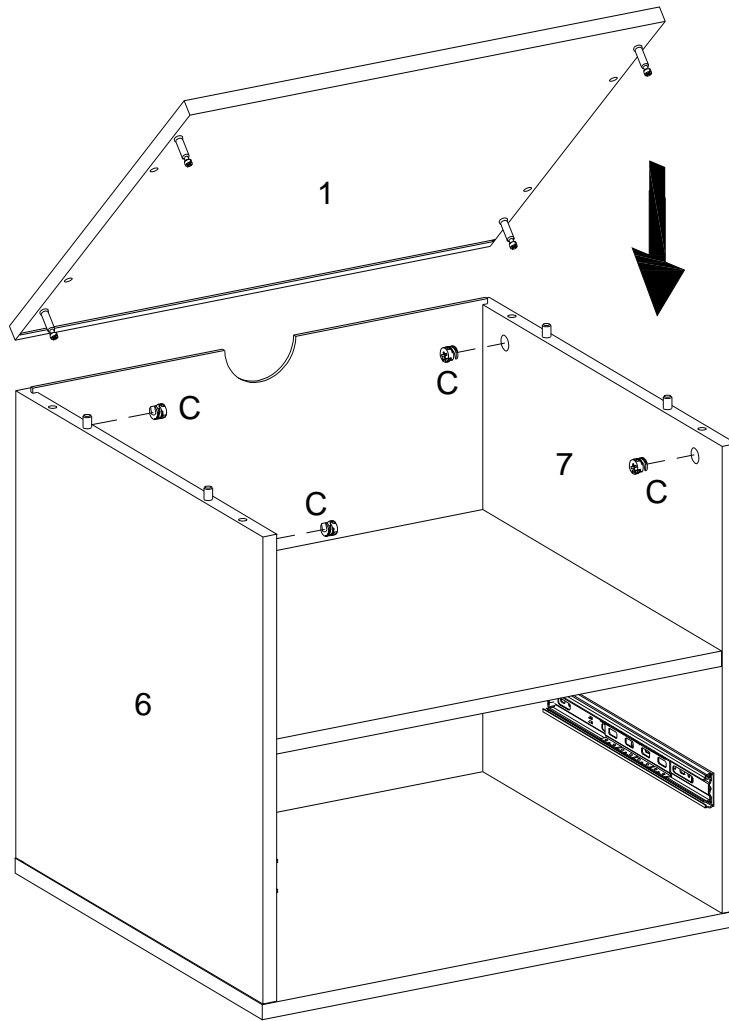
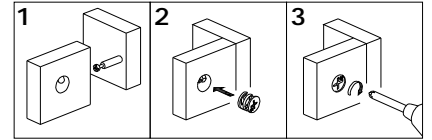

Using cam lock (C) secure part (1) into parts (6,7) with Philips head screwdriver as per diagram.

# Step 11

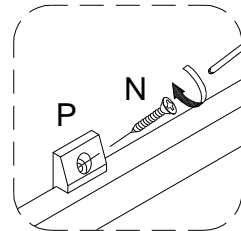
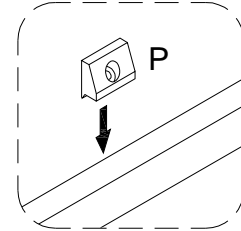
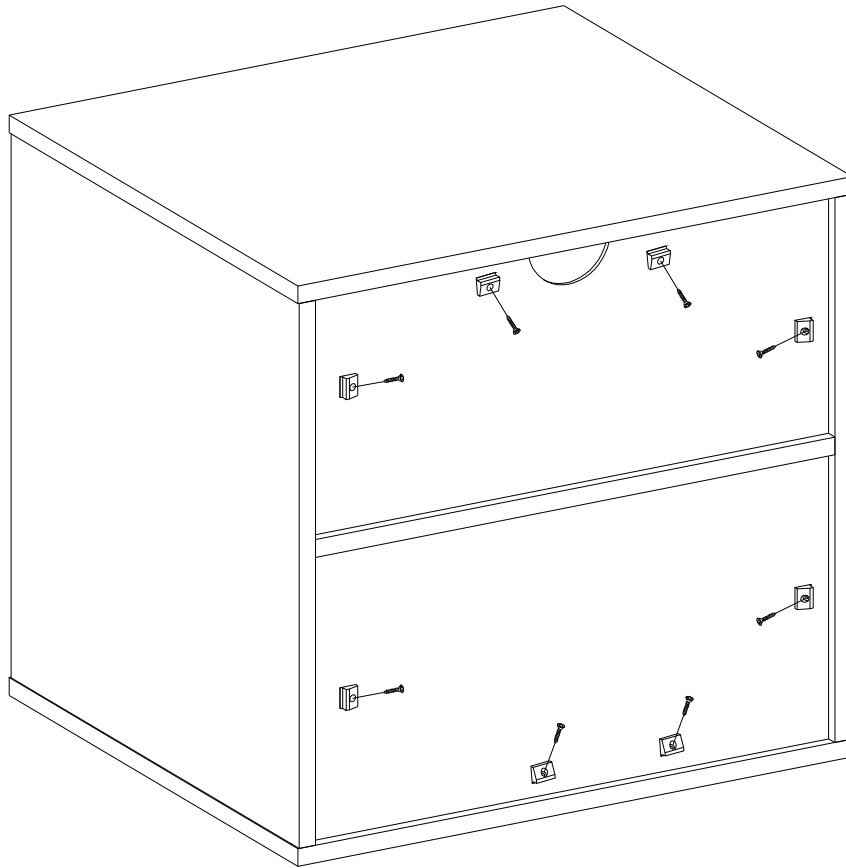

Using screw (N) secure plastic wedge (P) with Philips head screwdriver as per diagram.

# Step 12

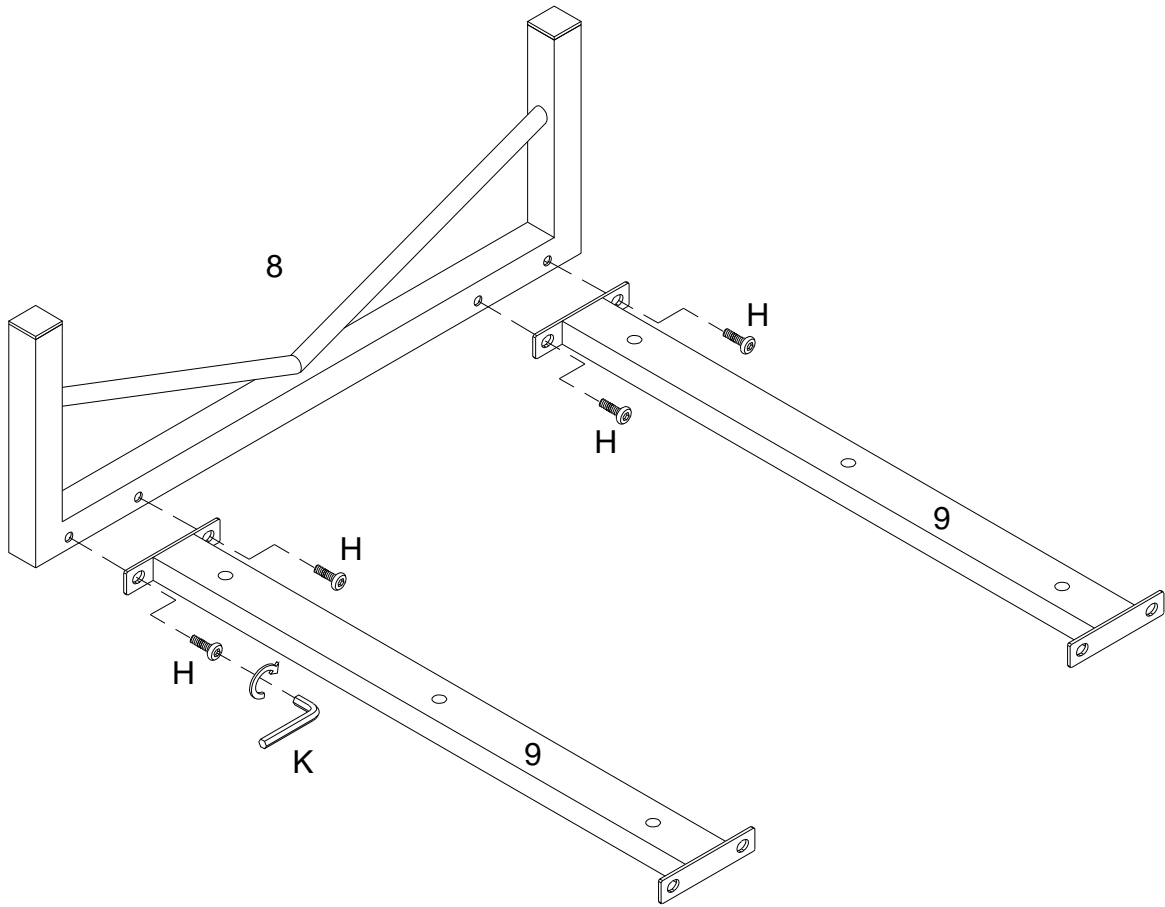

Using bolt (H) attach part (9) into part (8) with Hex key (K) as per diagram.

# Step 13

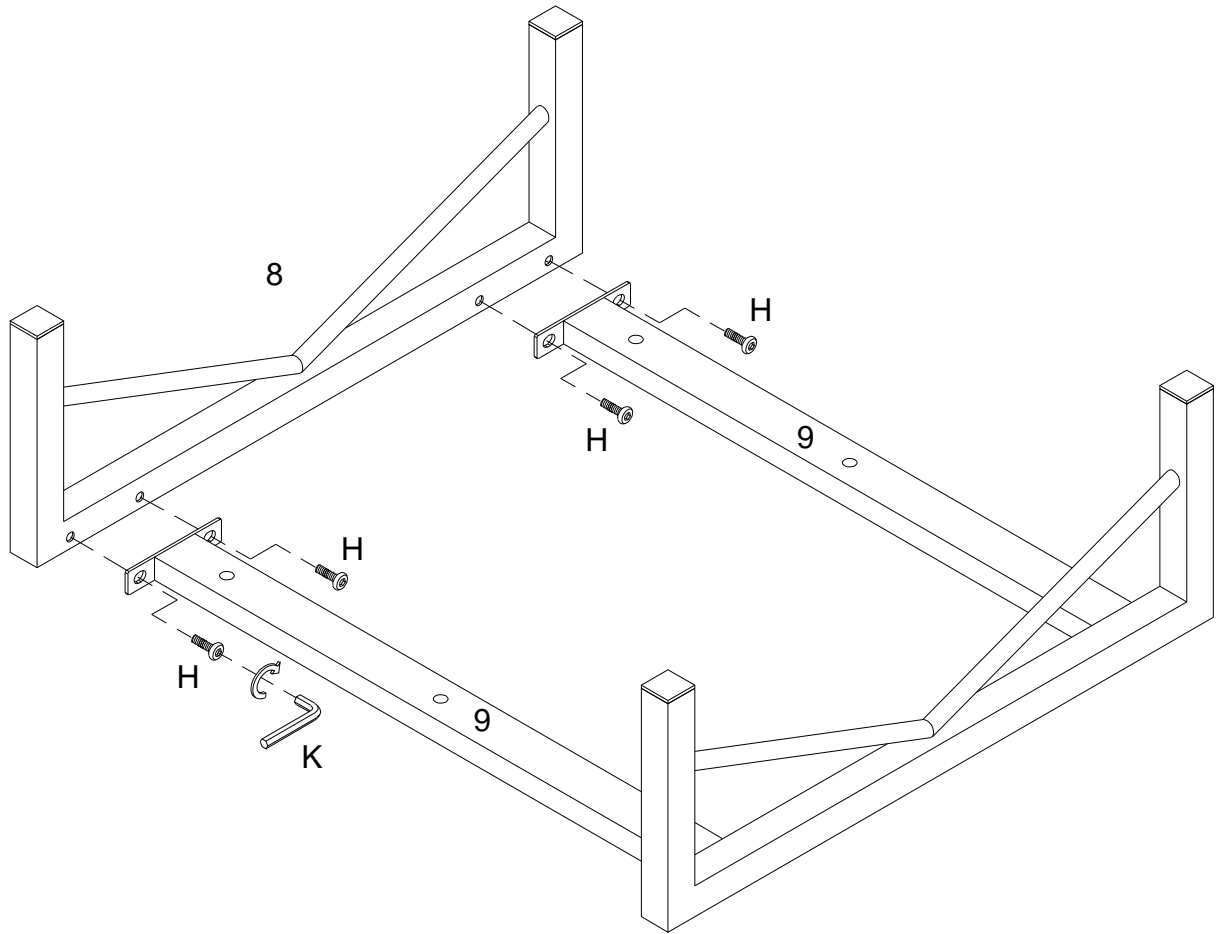

Using bolt (H) attach part (9) into part (8) with Hex key (K) as per diagram.

# Step 14

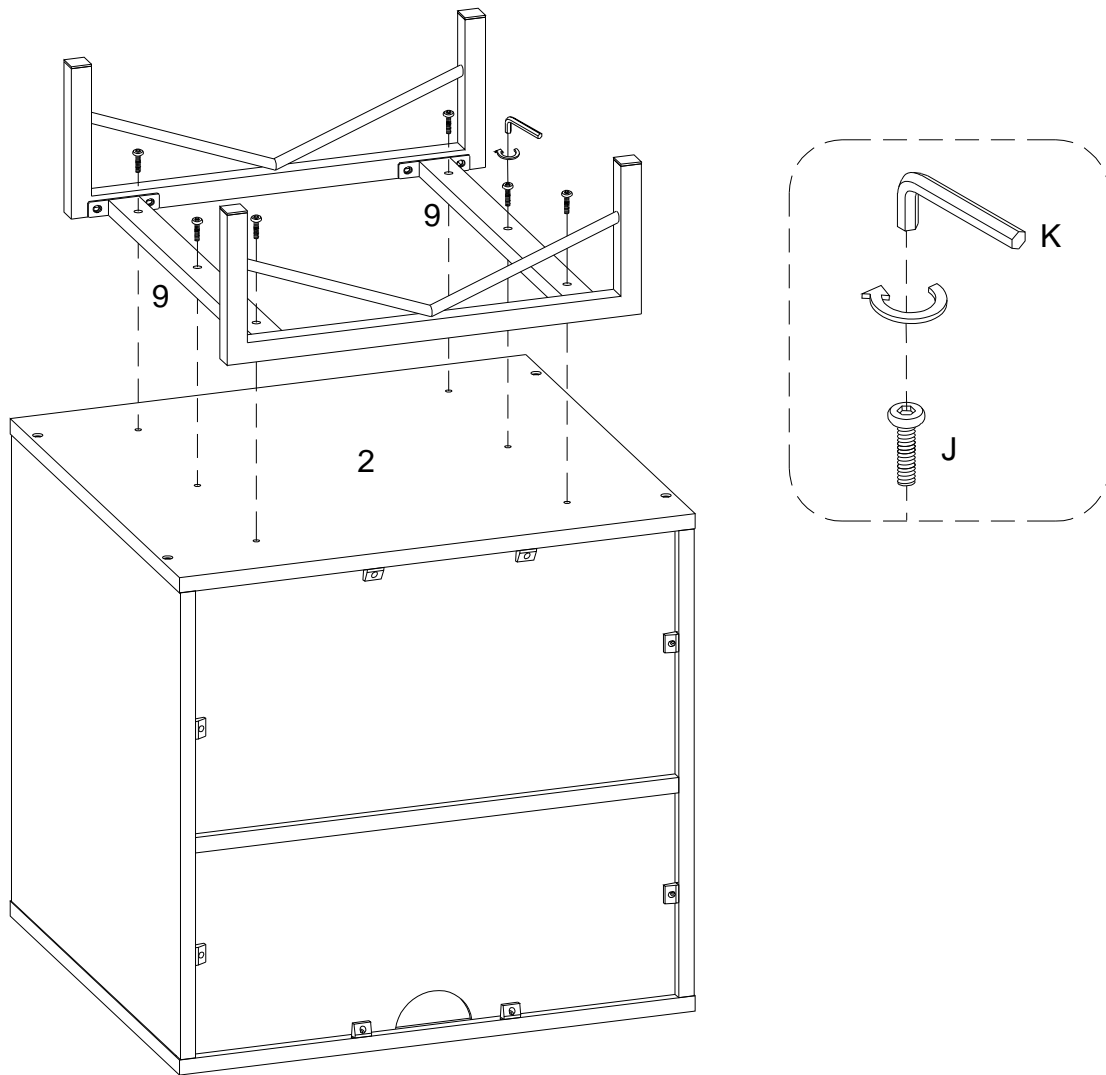

Using bolt (J) attach part (9) into part (2) with Hex key (K) as per diagram.

# Step 15

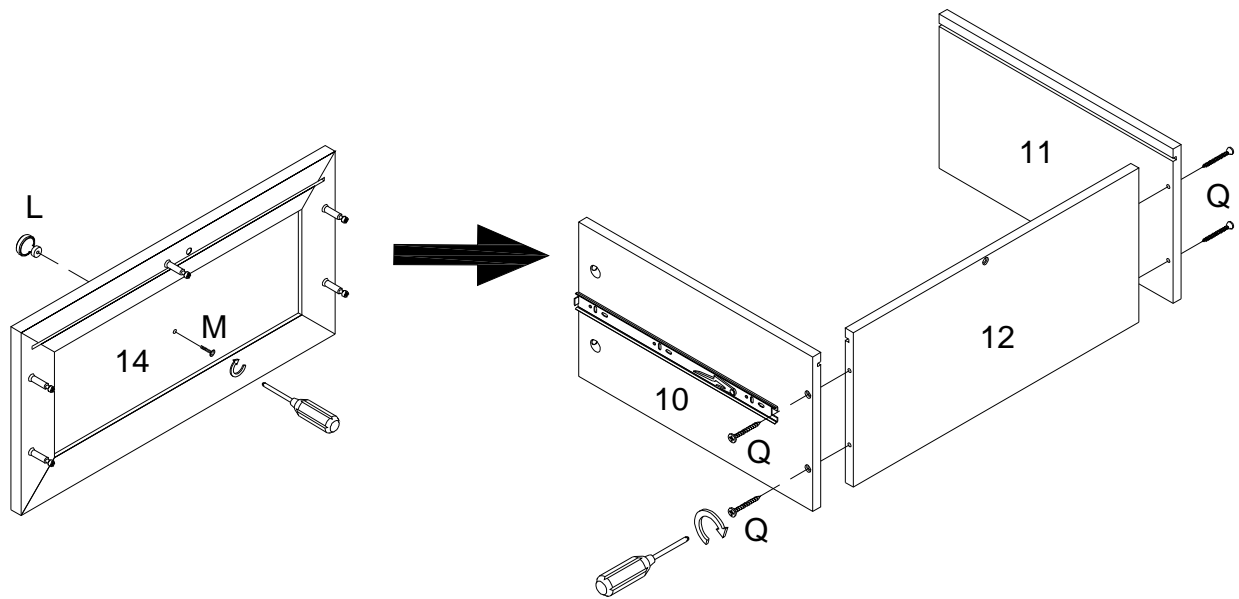

Using handle bolt (M) secure handle (L) to part (14) ,then using screw(Q) attach parts (10,11) to part (12) with Philips head screwdriver as per diagram.

# Step 16

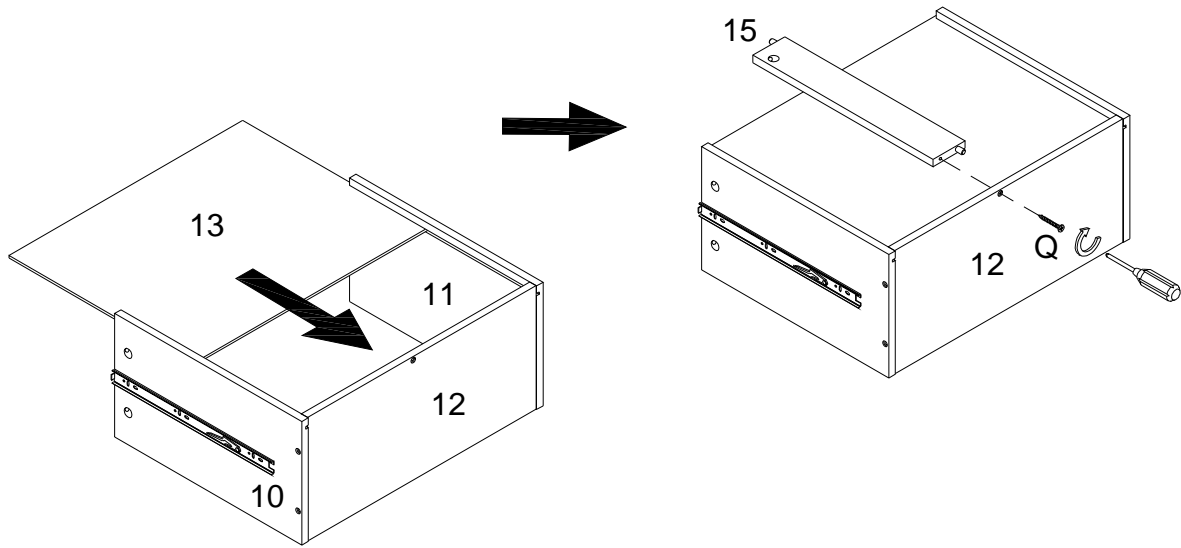

Put part (13) as per diagram. then use screw (Q) attach part (15) to part (12) with Philips head screwdriver as per diagram.

# Step 17

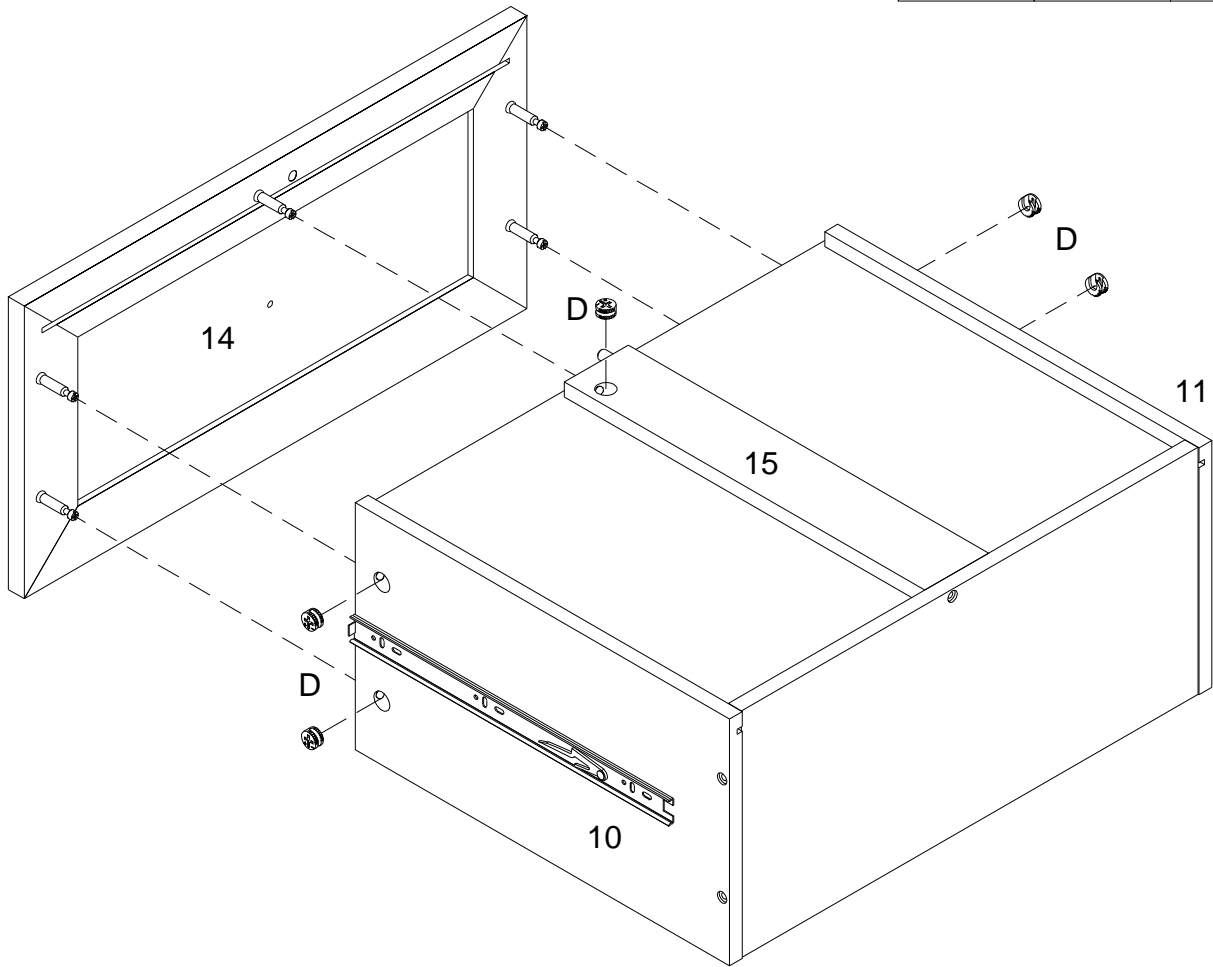
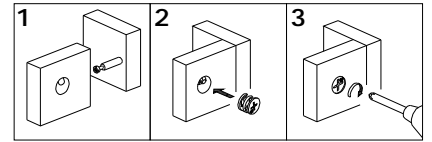

Using Cam lock(D) secure part (14) to parts (10,11,15) with Philips head screwdriver as per diagram.

# Step 18

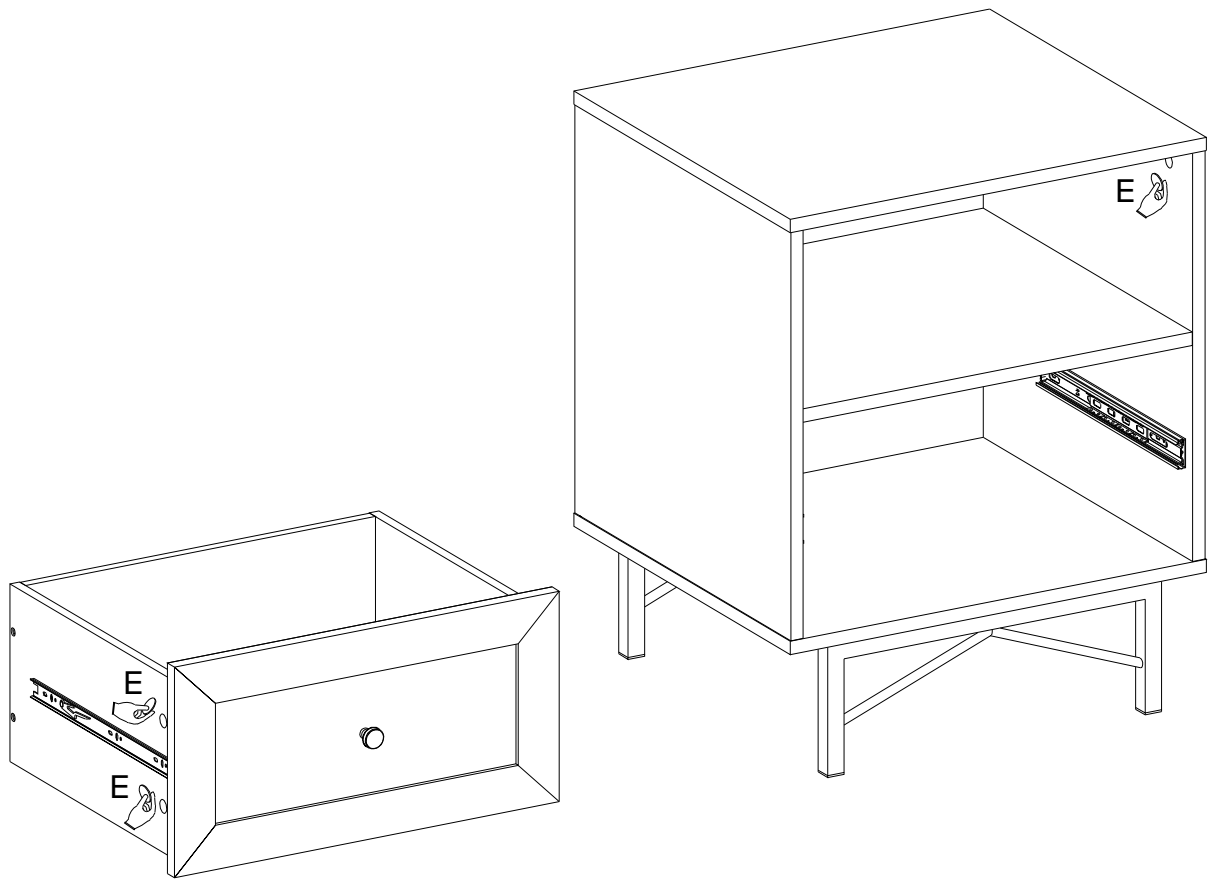

Place sticker (E) cover the holes as per diagram .

## Step 19

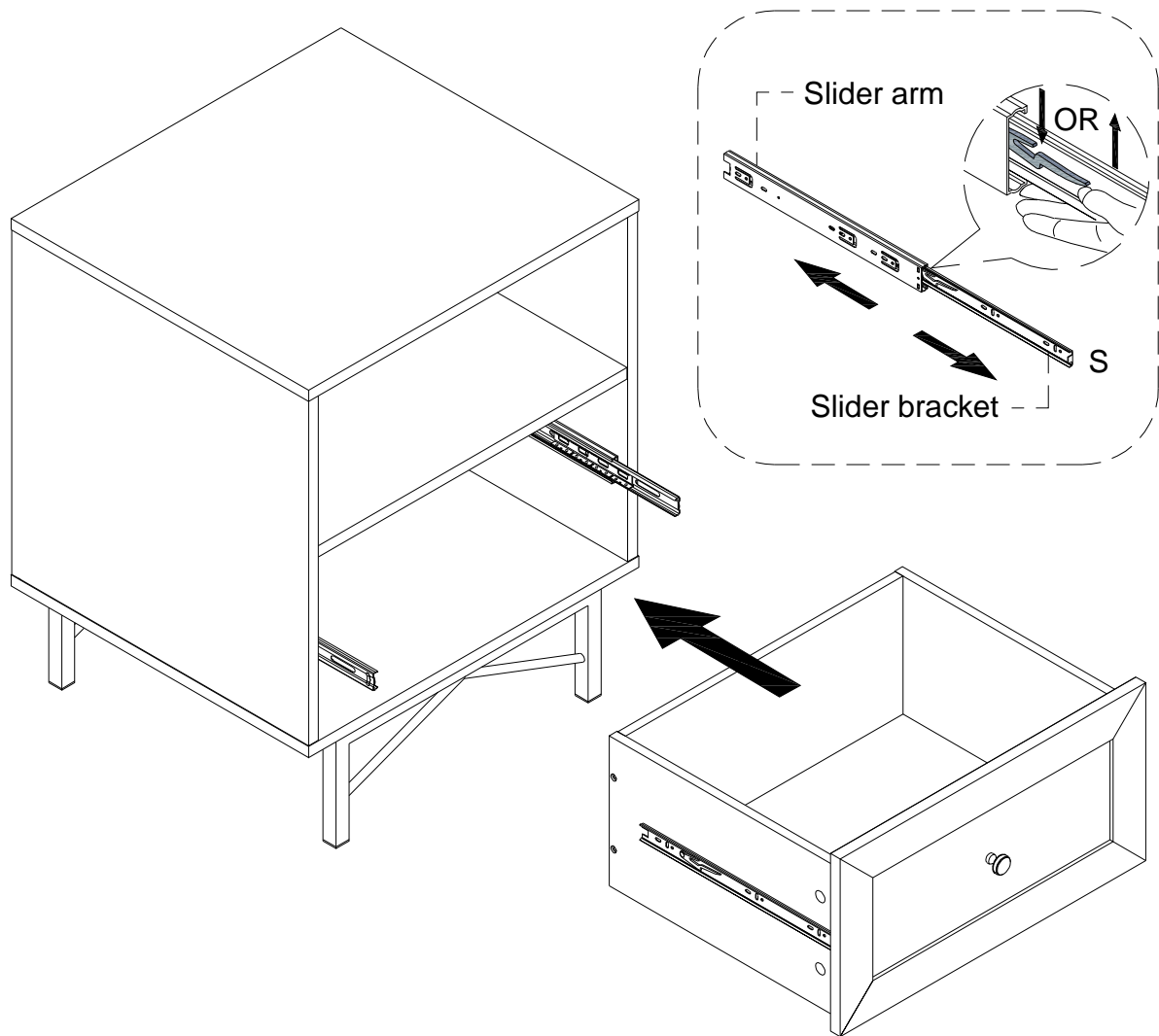

Insert the assembled drawers into the unit frame, extend the Ball Bearing Slide Tracks (S) on the pedestal Side Panel all the way forward .Then align the Slide Runners on the assembled drawers with the Slide Tracks and push the drawer carefully inside until it stops. Note : if the drawer does not go in smoothly, please take it out and repeat the step. If you need to remove the drawer, please pull the drawer all the way out,press or lift the plastic release lever and pull out the drawer and then re-assembled the drawer until it was going in smoothly .

# Step 20

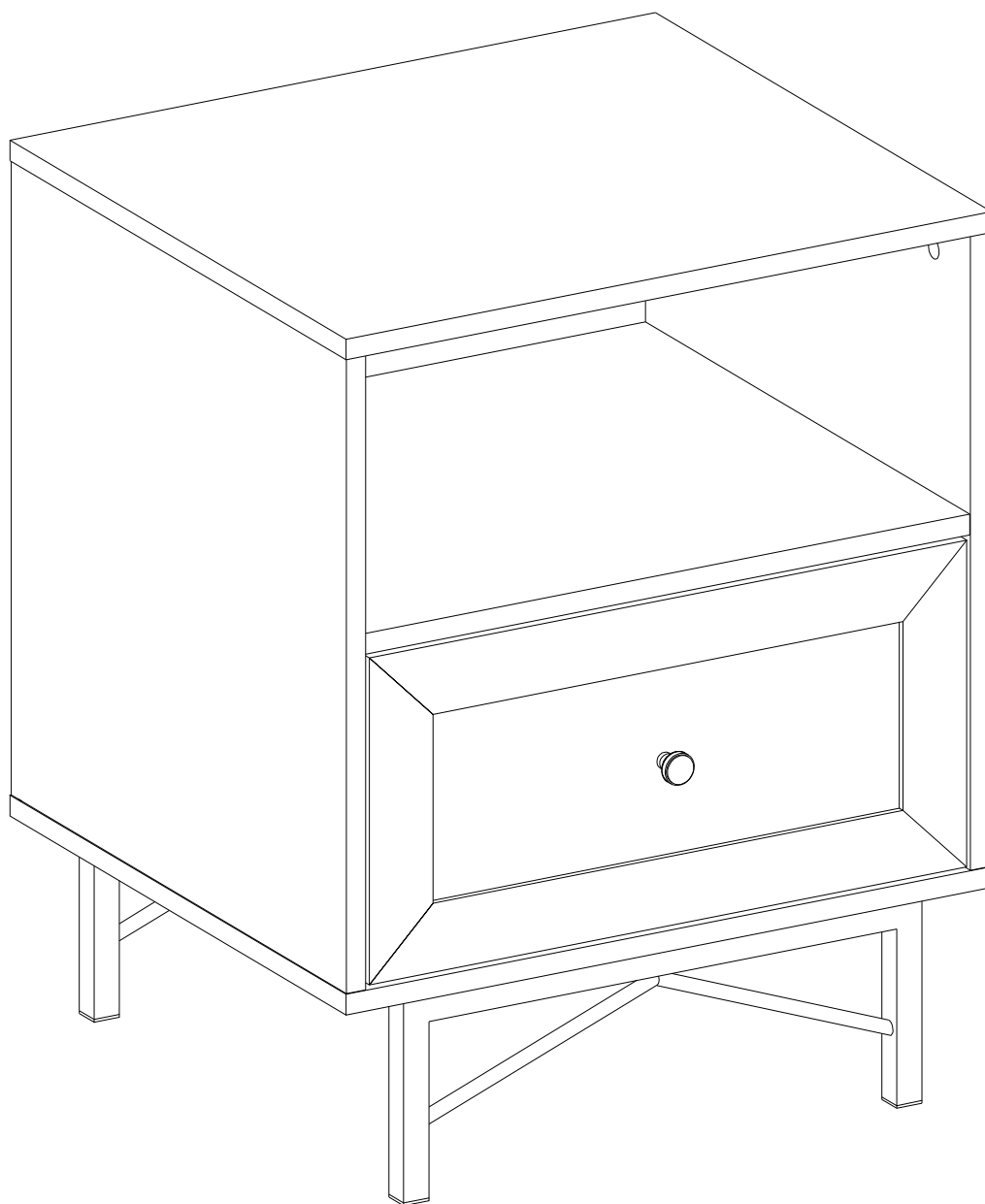

**Final Assembly**