











Assembly Instructions

Caution: You must read this before you proceed

Care & Maintenance

- ⊘  ● Not for commercial use. For residential use only.
 - ✓  ● Furniture may scratch floors. We recommend using furniture pads to protect your floors.
 - ⊘  ● Do not put hot items directly on furniture surface.
 - ⊘  ● Do not clean furniture with harsh cleansers or polish.
 - ⊘  ● Do not place furniture under direct sunlight.
 - ⊘  ● Do not place furniture near heating or cooling vents.
 - ⊘  ● Do not write on furniture without a padded barrier to protect the surface.
 - ⊘  ● Do not place furniture outside . For indoor use only.
 - ⊘  ● Stains may be removed with mild soap solution and damp cloth.
 - ⊘  ● Children should not climb or jump on the furniture.
- ✓  ● Dust and pick-up spills using a clean, non-colored, lint-free cloth.







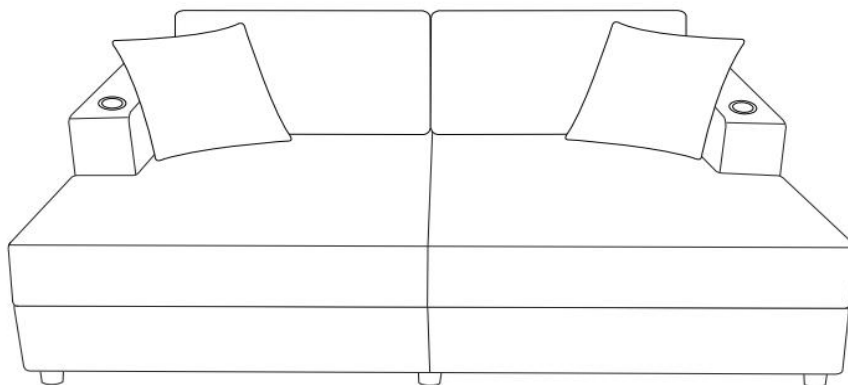













Please look in the magic tape pouch for hardware packs and legs.

Sets often ship in multiple boxes and may arrive a day or two apart.













SOFA



Part List

| Label | Picture | Description | QTY |
|-------|---|---|-----|
| A |  | Backrest | 1 |
| B |  | Left Armrest | 1 |
| C |  | Right Armrest | 1 |
| D |  | Front Rail | 2 |
| E |  | Left Rail | 1 |
| F |  | Right Rail | 1 |
| G |  | Short Wooden Batten | 1 |
| H |  | Long Wooden Batten | 1 |
| I |  | Middle Leg Connecting Wooden Batten (Left) | 1 |
| J |  | Middle Leg Connecting Wooden Batten (Right) | 1 |
| K |  | Back Middle Leg Connecting Wooden Batten | 1 |
| L |  | Bed Slat | 1 |
| M |  | Seat Cushion Package | 1 |
| M1 |  | Left Seat Cushion | 1 |
| M2 |  | Right Seat Cushion | 1 |
| N |  | Back Cushion | 2 |
| O |  | Pillow | 2 |
| P |  | Middle Leg | 1 |
| Q |  | Back Middle Leg | 1 |
| R |  | Leg | 7 |
| S |  | Power Cord | 1 |

Hardware List

| Label | Picture | Description | QTY |
|-------|---|-----------------------|-----|
| ① |  | Plastic Washer | 8 |
| ② |  | Allen Wrench | 1 |
| ③ |  | Bolt (M8*60) | 7 |
| ④ |  | Bolt (M8*45) | 8 |
| ⑤ |  | Bolt (M8*20) | 15 |
| ⑥ |  | Screw (M4*30) | 30 |
| ⑦ |  | Flat Washer | 30 |
| ⑧ |  | Spring Washer | 28 |
| ⑨ |  | Iron Connecting Plate | 1 |
| ⑩ |  | Iron Connecting Plate | 2 |
| ⑪ |  | Nut (M8) | 3 |
| ⑫ |  | Screwdriver | 1 |
| ⑬ |  | Spanner | 1 |

Assembly Preparation

Before
Beginning
Assembly:

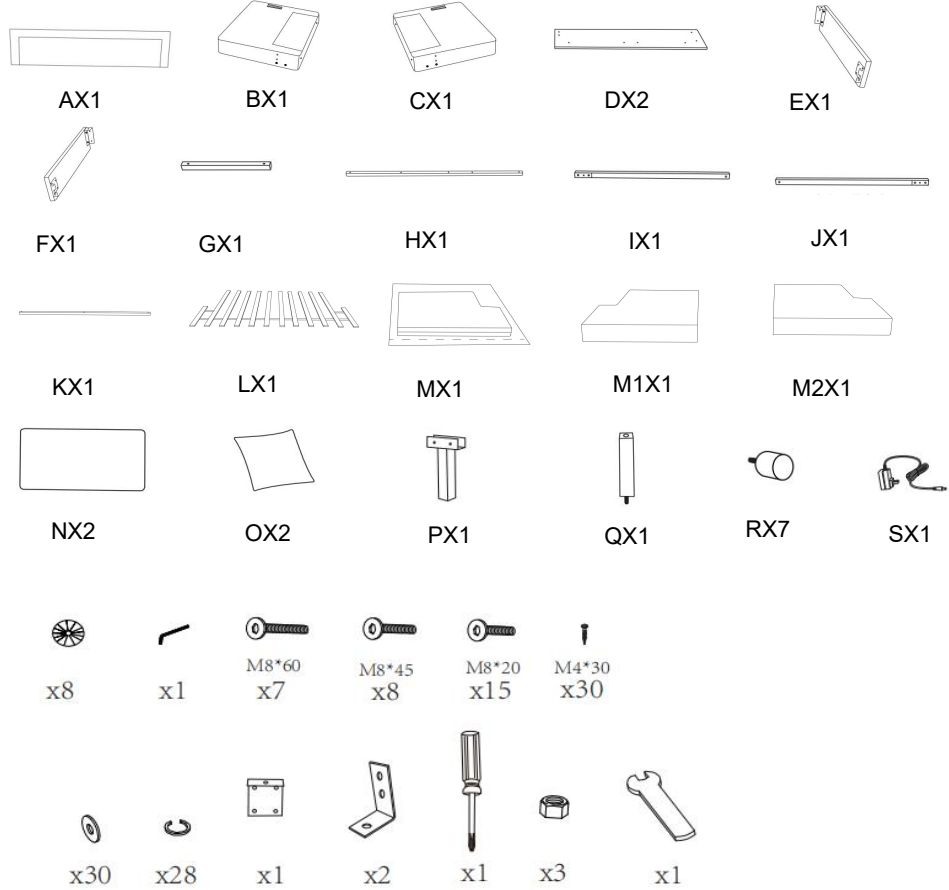

- Read instructions, cover to cover-



- Have 2 adults on hand for assembly-



- Do not assemble on flooring or carpet-



- Assemble on a clean non-marring surface (packing foam)-



- Save all packaging until finished-

Assembly Steps:

OVERVIEW

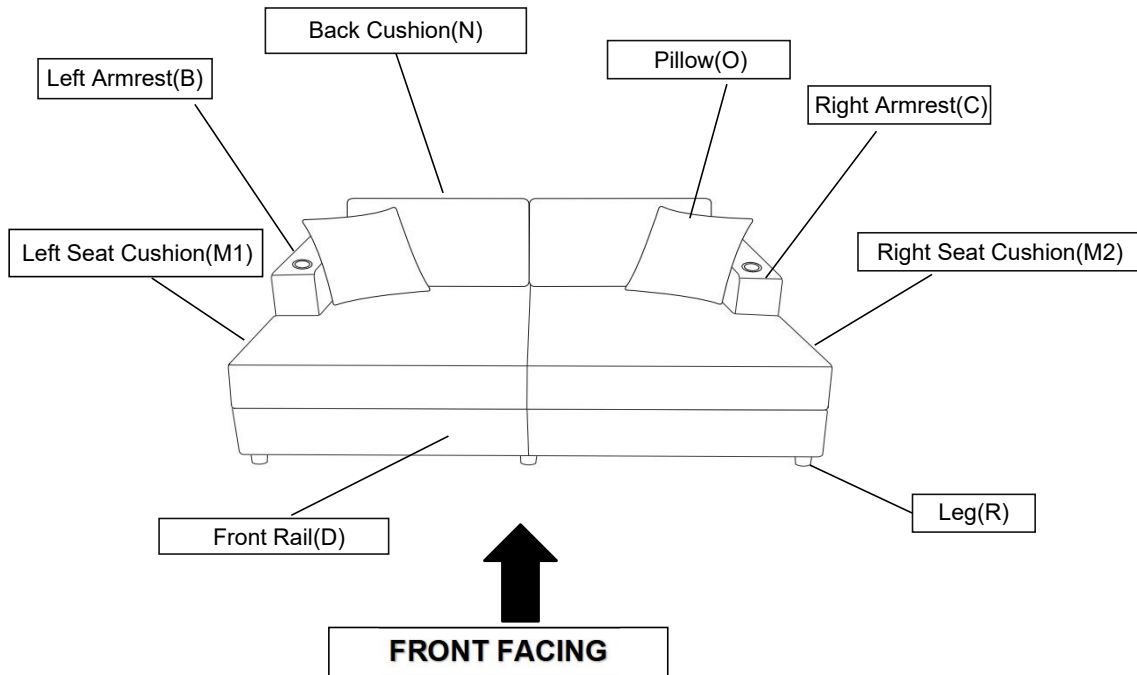

This Sofa has multiple parts and may require up to 30 minutes to assemble. To give you an overview of the Sofa parts, the above picture is to help you put the various Sofa parts into perspective. Please read through the instructions to familiarise yourself with the parts and steps before assembly.

Step 1

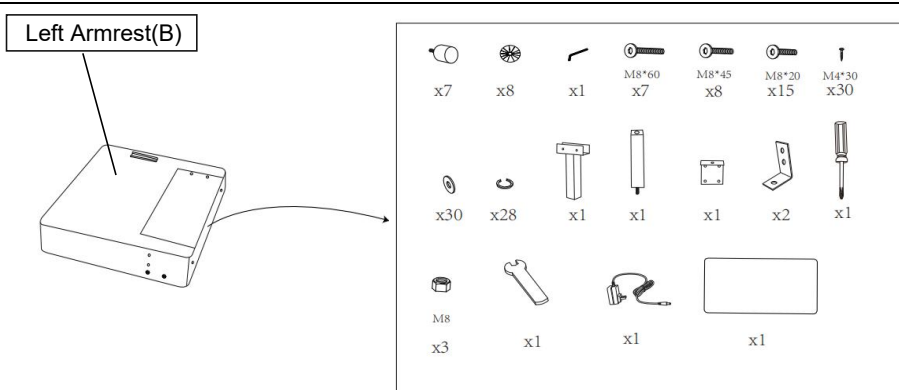

Remove the hardware and one Back Cushion(N) from the bottom of Left Armrest(B).

Step 2

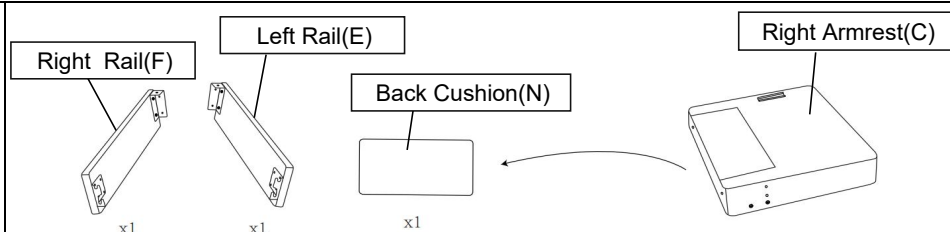

Remove the Left Rail(E), Right Rail(F) and one Back Cushion(N) from the bottom of Right Armrest(C).

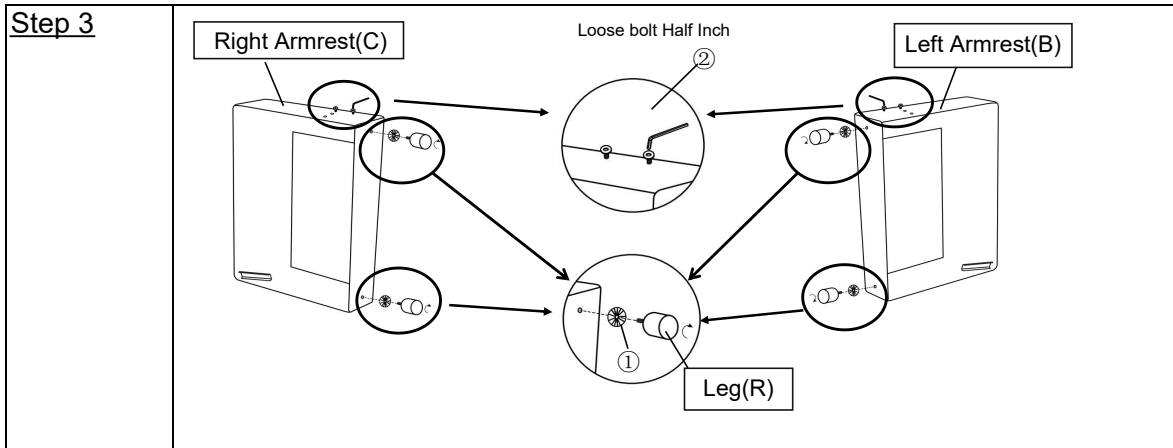

Step3.1.Install the Leg(R) at the bottom of Left Armrest(B) and Right Armrest(C) by placing Plastic Washer(①) on the threaded stem.Tighten by turning the Leg clockwise.
 Step3.2.Loose the bolts Half Inch by Allen Wrench(②).

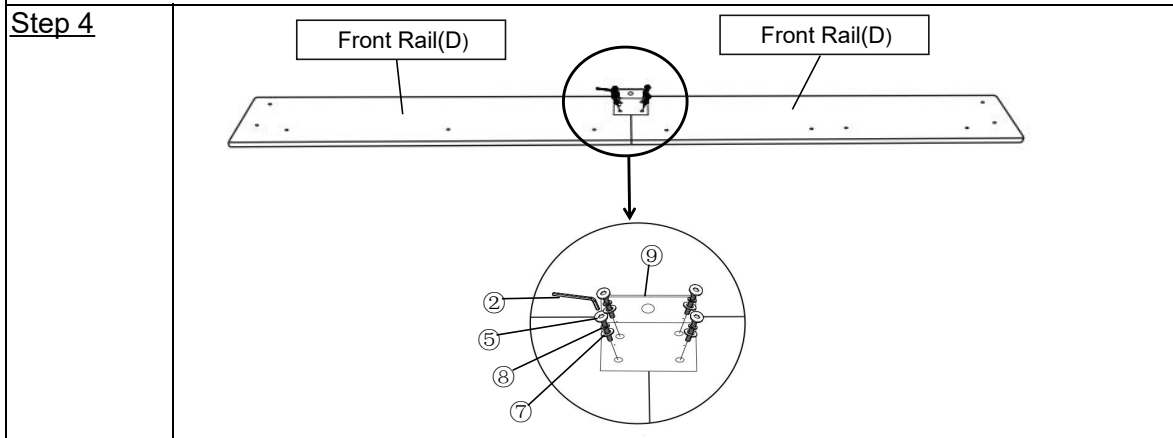

Connect two Front Rails(D) by using Iron Connecting Plate(⑨) ,Bolts(⑤),Spring Washer(⑧) , Flat Washer(⑦) with Allen Wrench(②) turning clockwise until tight.

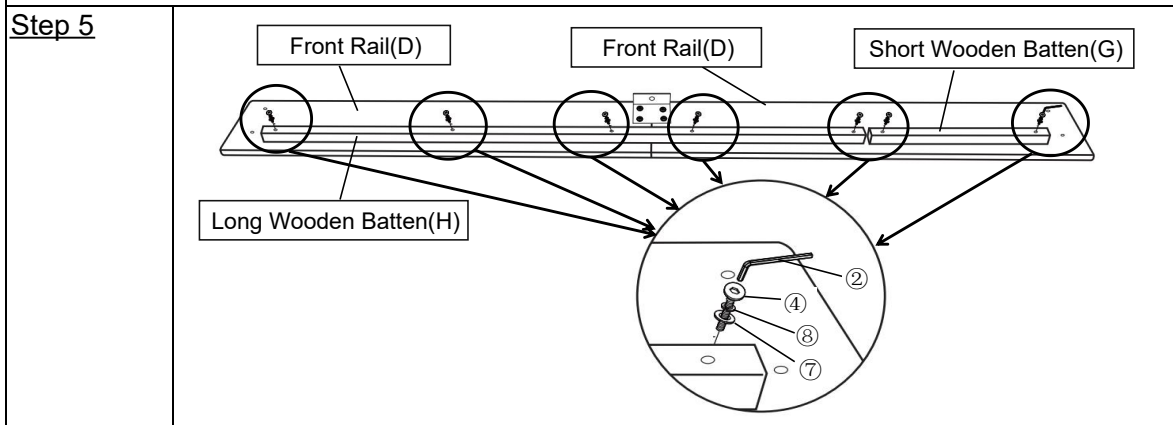

Put the Short Wooden Batten(G) and Long Wooden Batten(H) on Front Rail(D),using Bolts(④),Spring Washer (⑧) , Flat Washer(⑦) with Allen Wrench(②) turning clockwise until tight.

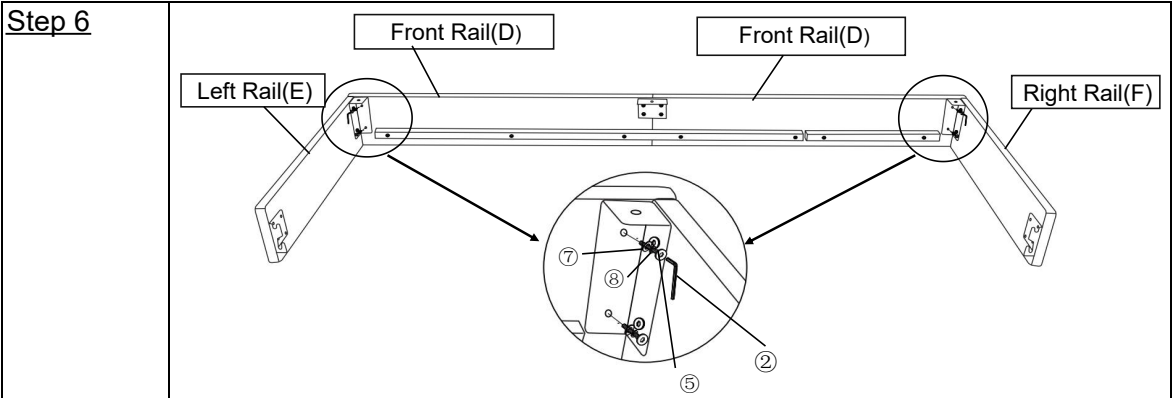

Attach the Left Rail (E) to the Front Rail (D), using Bolt (5), Spring Washer (8), Flat Washer (7) with Allen Wrench (2) turning clockwise until tight. Repeat the same step with Right Rail (F). Tighten the Bolts fully in a sequential manner.

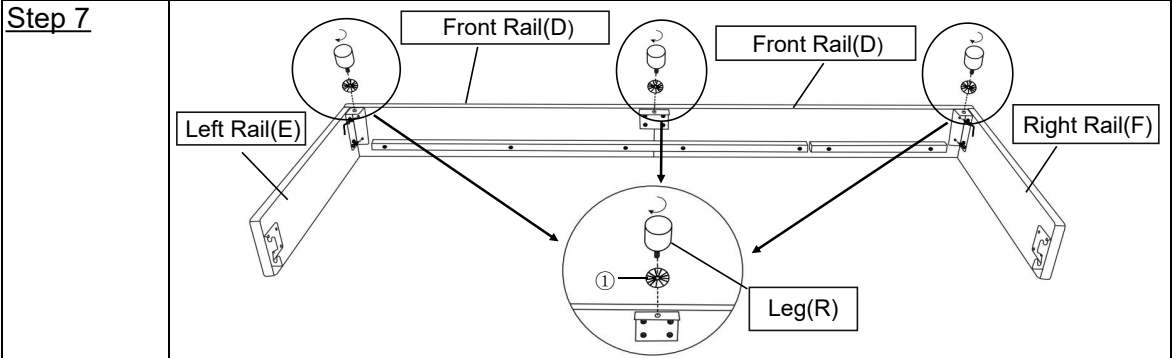

Install the Leg (R) on Front Rail (D) by placing Plastic Washer (1) on the threaded stem. Tighten by turning the Leg clockwise.

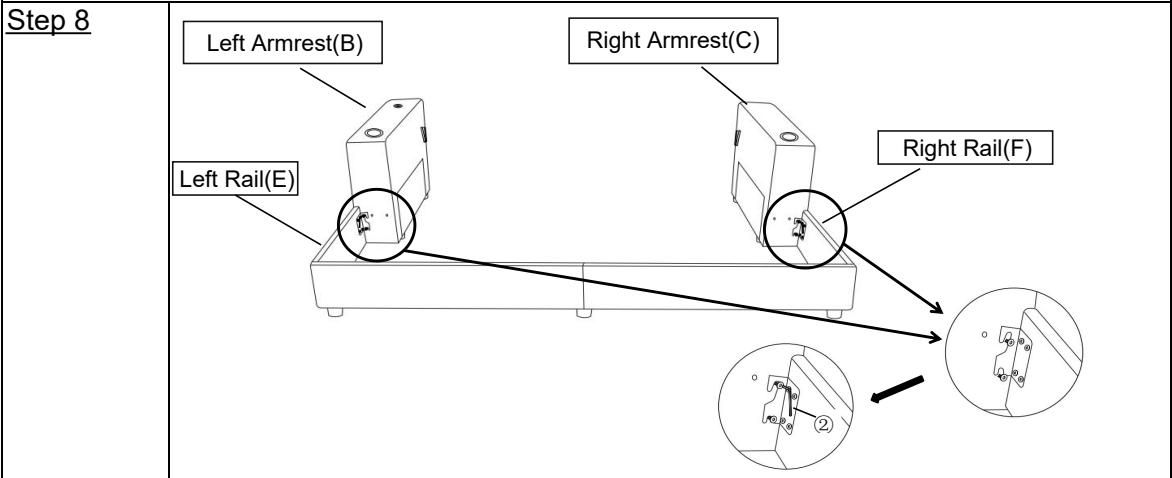

With the assistance of your partner, slide the hooks of Left Rail (E) and Right Rail (F) into the bolts of Left Armrest (B) and Right Armrest (C) and tighten the Bolts with Allen Wrench (2) as shown above.

Step 9

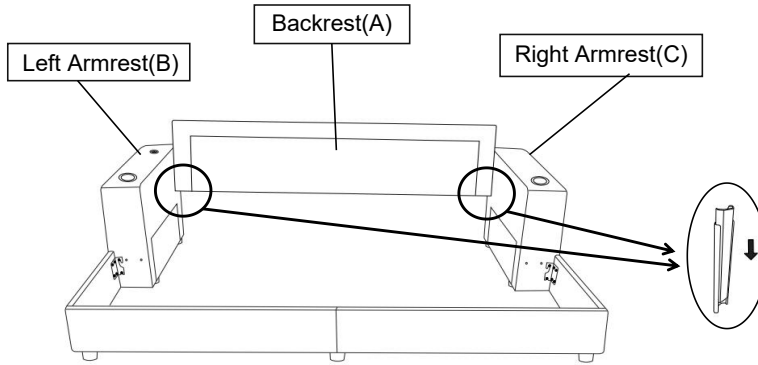

Slide the Tapered Connectors on the Backrest(A) into the Tapered Connectors on the Left Armrest(B) as shown in the picture. Repeat the same steps with the Right Armrest(C).
Note: Make sure the Tapered Connectors on Backrest(A) lock into the Tapered Connectors on the Left Armrest(B) and Right Armrest(C). Assistance from an adult partner is necessary for this assembly process. During this assembly process - do exercise caution. You may need to use your hand to press down or pave away the padded surface to facilitate the 'slip and slide' assembly.
Caution: Ensure that your fingers do not get caught or pinched in the assembly process.

Step 10

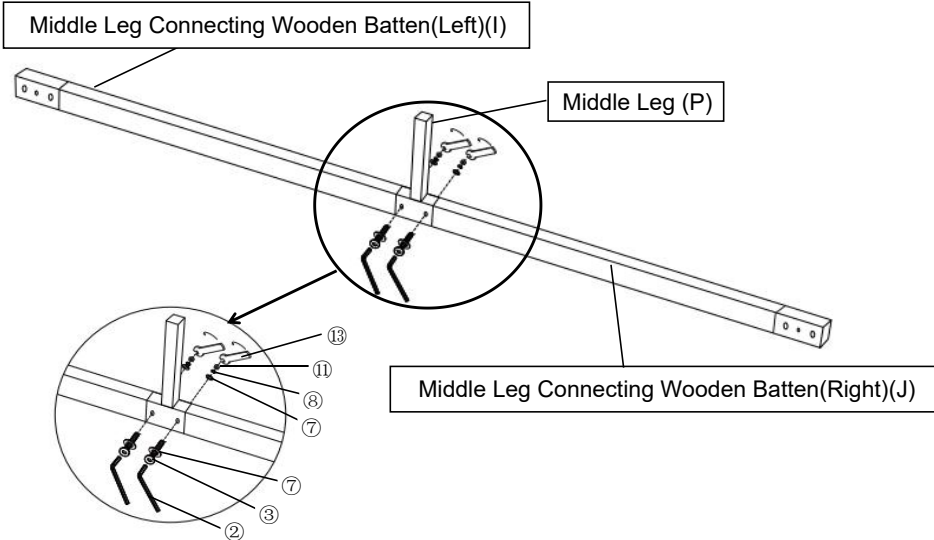

Assemble the Middle Leg(P) on two Middle Leg Connecting Wooden Batten(I) and(J) by using Bolt(3) ,Flat Washer(7) and Allen Wrench(2),Nut(11),Spring Washer(8),Flat Washer(7),and Spanner(13) turning clockwise until tight.

Step 11

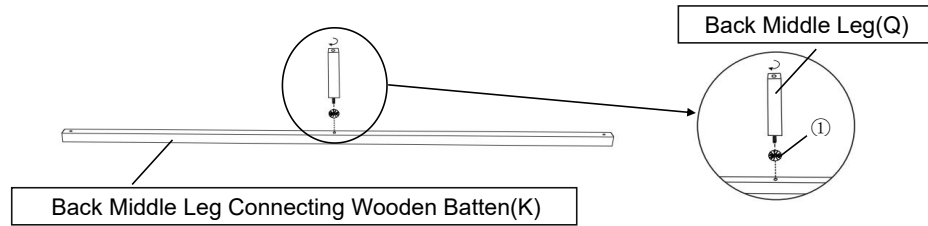

Install the Back Middle Leg(Q) on Back Middle Leg Connecting Wooden Batten(K) by placing Plastic Washer (1) on the threaded stem.Tighten by turning the Leg clockwise.

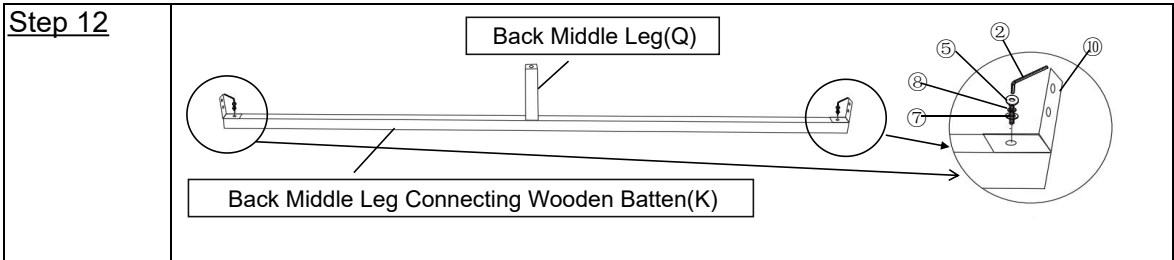

Install the Iron Connecting plate(10) on two sides of Back Middle Leg Connecting Wooden Batten (K) by using Bolt(5), Spring Washer(8) ,Flat Washer(7) and Allen Wrench(2),turning clockwise until tight.

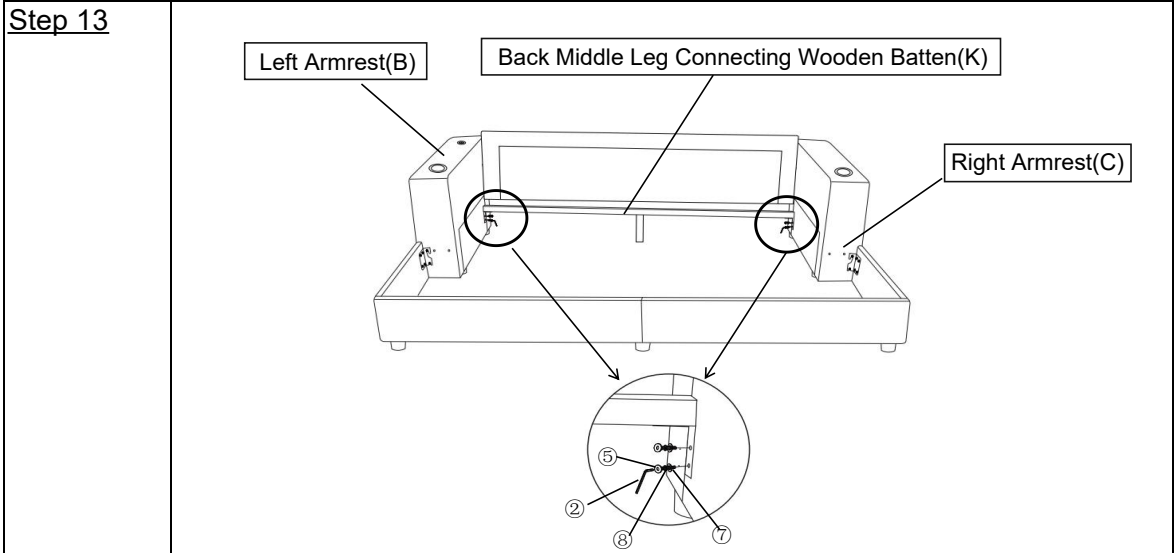

Install the Back Middle Leg Connecting Wooden Batten (K) on the Left Armrest(B) and Right Armrest(C) by using Bolt(5), Spring Washer(8) ,Flat Washer(7) and Allen Wrench(2),turning clockwise until tight.

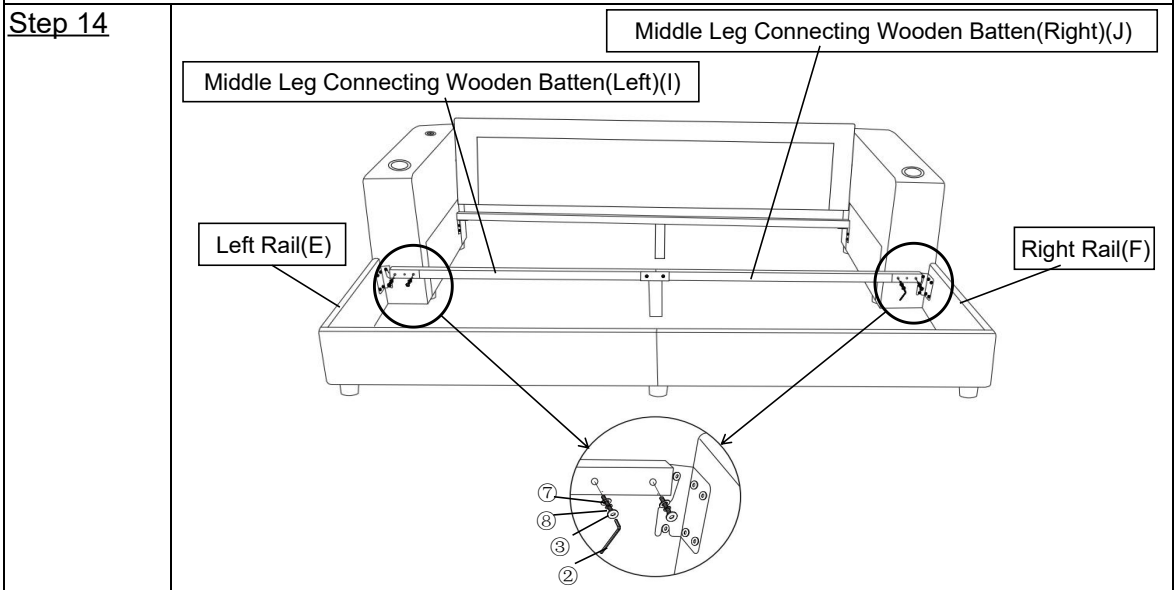

Install the Middle Leg Connecting Wooden Batten(I) and(J) on the Left Rail(E) and Right Rail(F) by using Bolt (3), Spring Washer(8) ,Flat Washer(7) and Allen Wrench(2),turning clockwise until tight.

Step 15

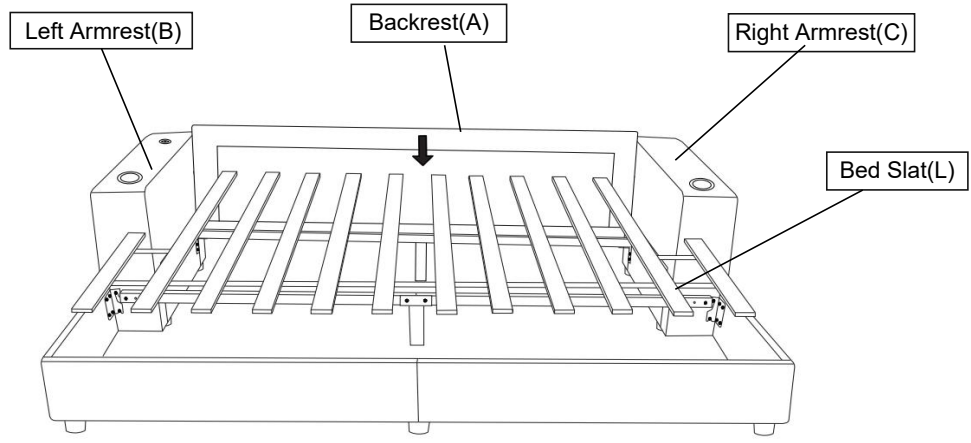

Put the Bed Slat(L) on the LOVESEAT CHAISE LOUNGE.

Step 16

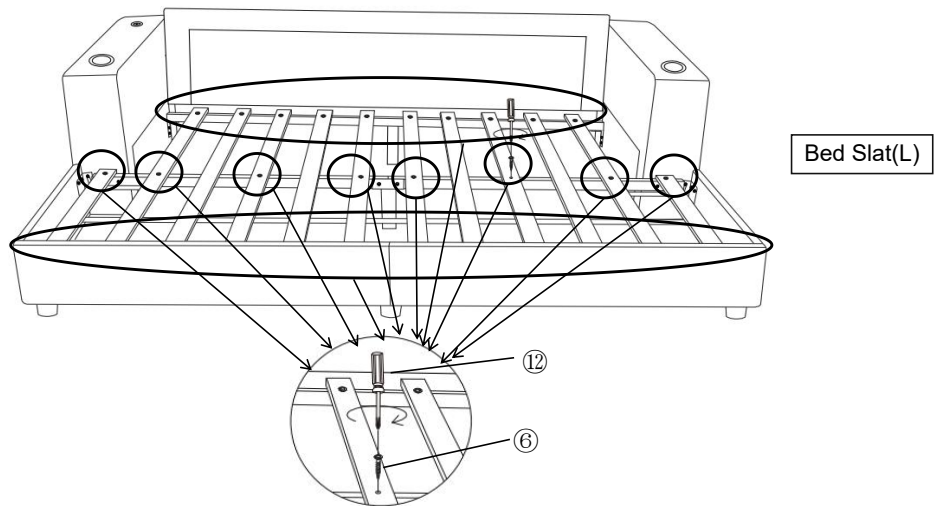

Use a screwdriver(12) to fix the screw(6) and the bed slat(L) to the slat.A total of 30 screws are needed.

Step 17

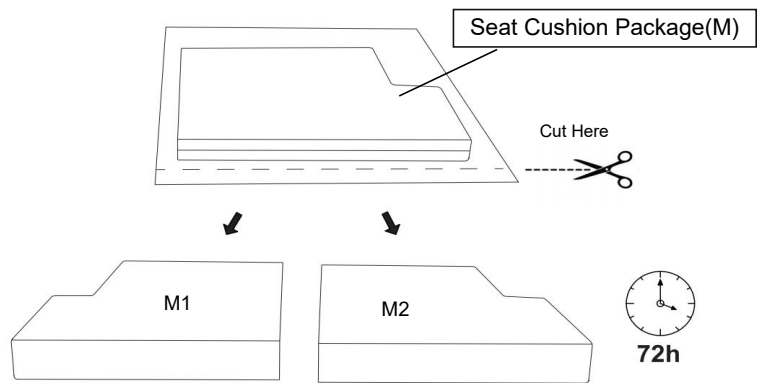

Cut the Seat Cushion Package(M) , then take out Seat Cushion(M1 M2).Full decomposition may take up to 72 hours.

Step 18

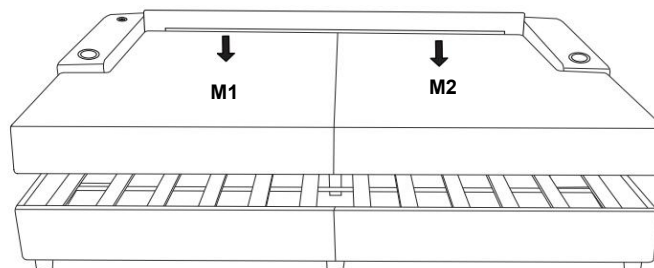

Put the Seat Cushion(M1 M2) on the LOVESEAT CHAISE LOUNGE.

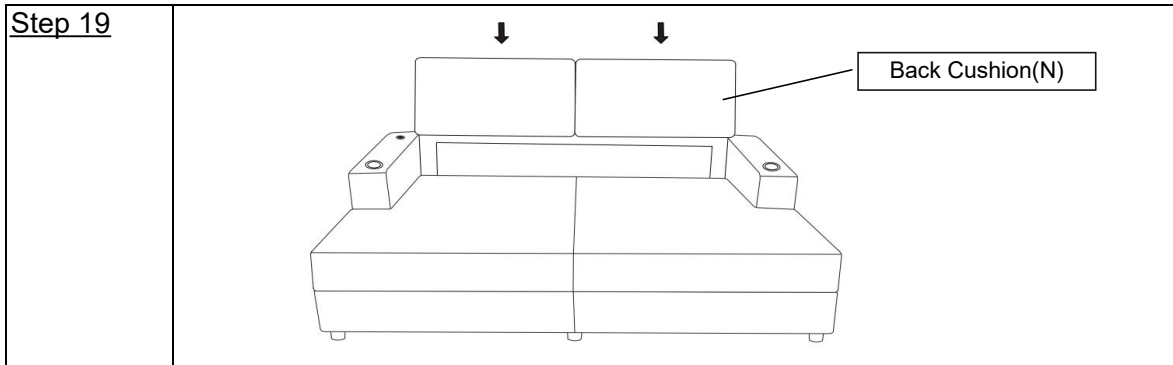

Put the Back Cushion(N) on the LOVESEAT CHAISE LOUNGE.

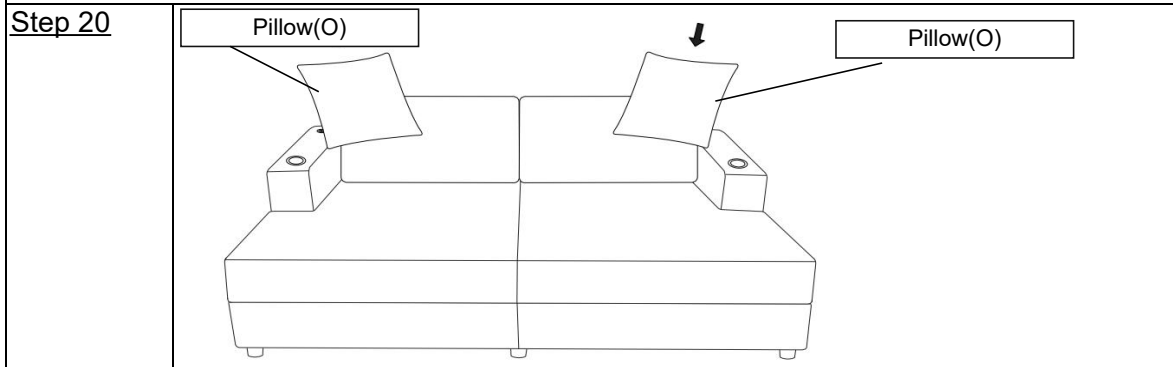

Put the Pillow(O) on the LOVESEAT CHAISE LOUNGE.

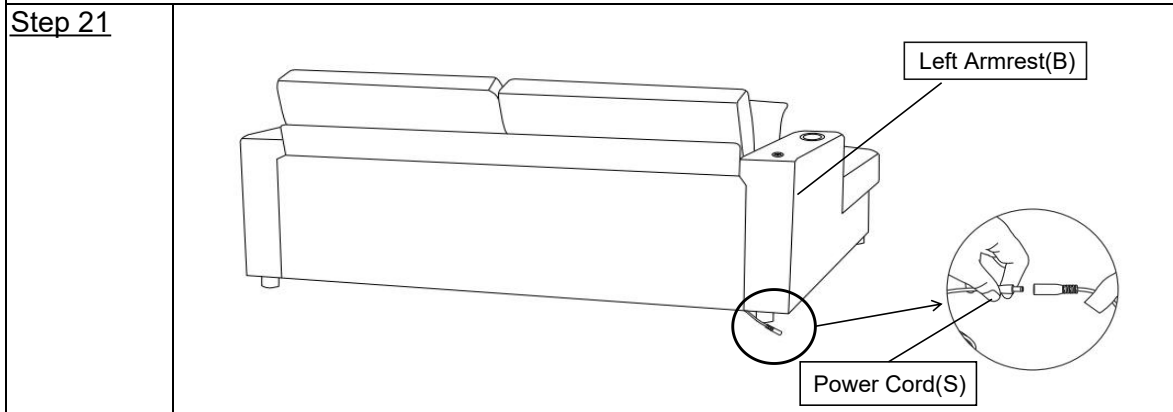

As shown in the picture, the power cord can be used normally.

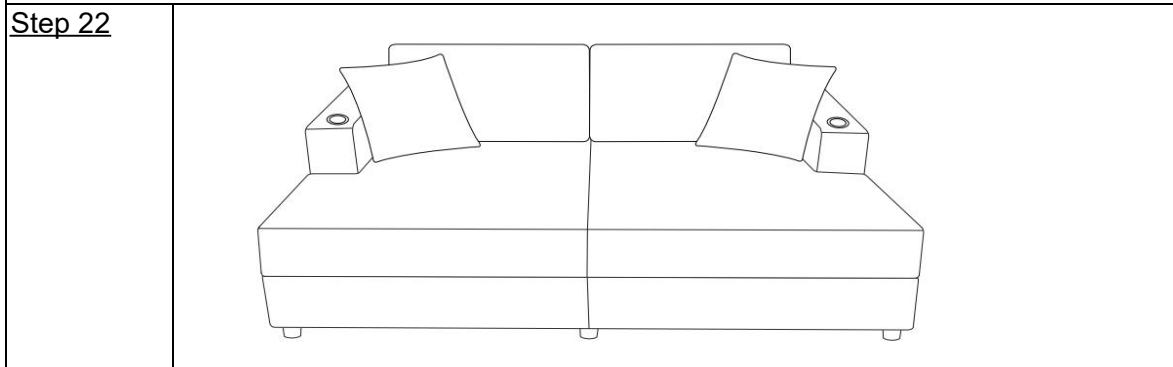

Your SOFA is ready to use.
This SOFA can only be used on a flat, level surface.