

Coffee table×1 Side table×2

Assembly Instruction – Please keep properly for future reference.

If you find any missing boxes, damaged parts, or accessory shortages, please contact the customer service team of your purchasing channel immediately. We will resolve the issue as quickly as possible.

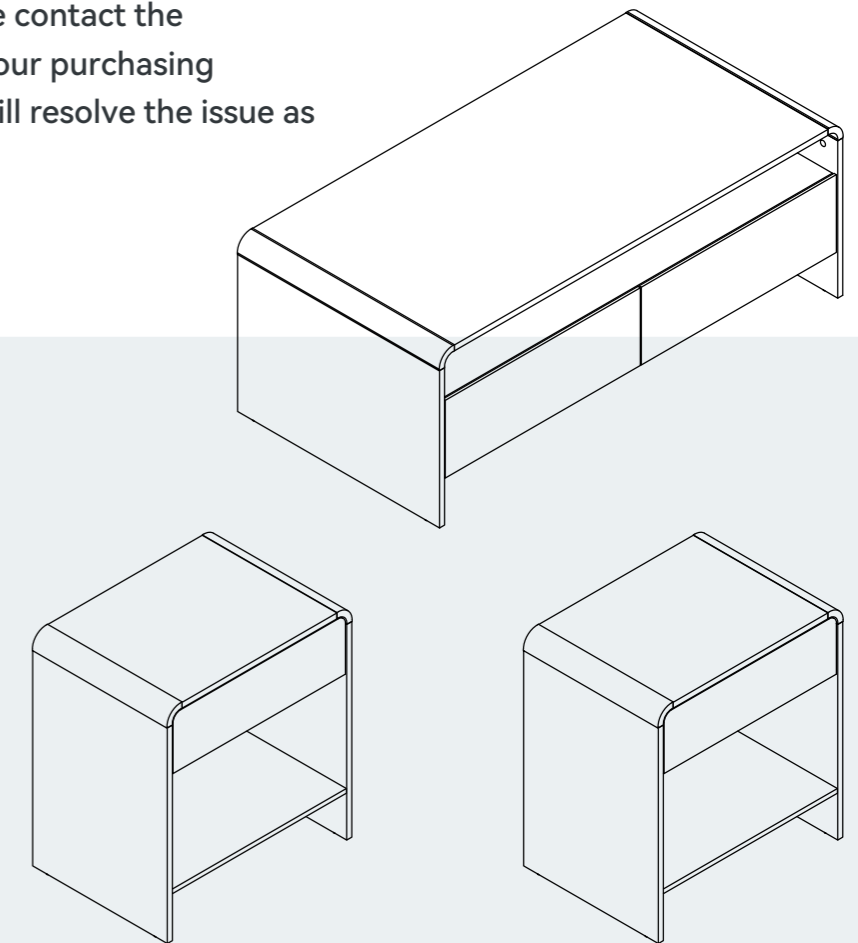

CONTACT US

- **Email:** service@grandtunnel.com
In order to receive assistance more quickly, please provide

THE FOLLOWING INFORMATION:

- Order number
- Purchase platform
- Purchase date
- Detailed description of the issue along with photos (if applicable)

Important – Please read these instructions carefully before starting the installation.

SKU
BG05X8-1A3A0
BG05X8-1A3B0
BG05X8-1A3C0

V1.0

EN

Coffee table×1 Side table×2

Before Assembly



Thank you for choosing our product!

To ensure a smooth installation process, please read this guide carefully to familiarize yourself with the required tools, materials, and installation steps.

Follow the relevant sections to avoid any damage caused by improper installation, and make sure to review all operation and safety guidelines for correct installation procedures.

Packaging Notice:

If you find any missing boxes, damaged parts, or accessory shortages, please contact the customer service team of your purchasing channel immediately. We will resolve the issue as quickly as possible.

Safety and Care Advice



Important :

Please read these instructions fully before starting assembly.

- Check you have all the components and tools listed on the following pages.
- Remove all fittings from the plastic bags and separate them into their groups.
- Keep children and animals away from the work area, small parts could choke if swallowed.
- Make sure you have enough space to layout the parts before starting.
- During assembly do not stand or put weight on the product, this could cause damage.
- Assemble the item as close to its final position (in the same room) as possible.
- Assemble on a soft level surface to avoid damaging the unit or your floor.
- Parts of the assembly will be easier with 2 people.



- To reduce the likelihood of damaging your product please ensure that your power drill is set on a low torque setting.

Care and Maintenance

- Only clean using a damp cloth and mild detergent, do not use bleach or abrasive cleaners.
- From time to time check that there are no loose screws on this unit.
- This product should not be discarded with household waste. Take to your local authority waste disposal center.

Handy Hints

- Assemble all parts and bolts loosely during assembly, only once the product is complete should you fully tighten the bolts.
- Regularly check and ensure that all bolts and fittings are tightened properly.

Warning

In order to help prevent overturning, please follow these instructions.

- Use the anti tip strap or wall fixing method provided (if applicable).
- Do not allow children to climb or hang on the furniture.
- Do not open more than one drawer at a time.
- Do not place heavy items in the top drawers.
- Do not place heavy items on top of the furniture, unless the furniture has been designed for this purpose.
- Please note that only the anti tip strap is provided. You will need to provide wall plugs and screws applicable for your wall type.

Customer Service Guide



Thank you for choosing our product! We are committed to providing you with excellent service. If you find any missing parts, damaged packaging, or product damage after receiving all packages, please follow the steps below to quickly contact our customer service team. We will do our best to resolve your issue.

1. Missing Parts

Verify Parts:

1. Refer to the “Parts List” in the manual to verify the name, specifications, and quantity of the missing parts.
2. Take a clear photo of the parts list and mark the missing parts with detailed information, e.g., “Missing 5 pieces of M6×30mm screws.”

Contact Us:

By Email:

Send an email to service@grandtunnel.com, with the subject line “Missing Parts Issue.” Include the following in the email:

- A description of the missing parts and a photo of the parts list.
- Order details (order number, purchase platform, purchase date).

2. Product or Packaging Damage

If it affects normal use:

Steps:

1. Take clear photos or videos showing the damaged parts and the extent of the damage (multi-angle shots are recommended).
2. Email the photos/videos along with order details to service@grandtunnel.com, with the subject line “Product Damage Issue.”

Resolution:

After verification, we will arrange for a replacement part, product exchange, or refund as quickly as possible.

If it does not affect normal use:

Steps:

1. Contact our customer service team (by email: service@grandtunnel.com).
2. Provide a description of the damage and include relevant photos or videos.

Resolution:

We will provide repair guidance or an appropriate compensation plan based on the specific situation.

Contact Us:

Customer Service Email: service@grandtunnel.com

Helpful Tips

To process your issue efficiently, please prepare the following information:

- Order details (order number, purchase platform, purchase date).
- Clear photos or videos.
- We are committed to providing quick and professional solutions, no matter the size of the issue, to ensure your satisfaction.

Thank you for your trust and support!
We hope you enjoy using our product!

Parts List - Panels



Please check you have all the panels listed below.

 1 x2	 2 x2	 3 x2
 4 x2	 5 x4	 6 x2
 7 x2	 8 x2	 9 x2
 10 x2	 11 x2	 12 x2

 13 x2	 14 x2	 15 x1
 16 x1	 17 x1	 18 x2
 19 x1	 20 x1	 21 x1
 22 x1	 23 x1	 24 x1
 25 x1	 26 x2	 27 x2

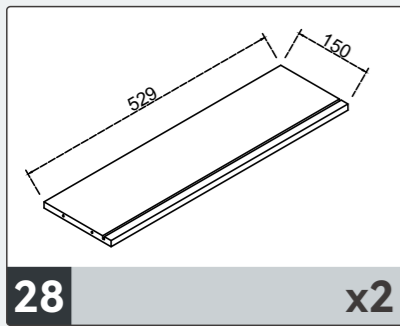

28 x2

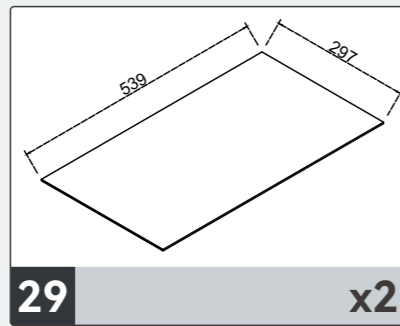





29 x2

Parts List - Fittings

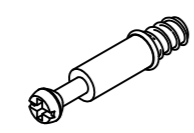

Please check you have all the fittings listed below.

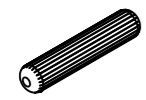
Note: The quantities below are the correct amount to complete the assembly. In some cases more fittings may be supplied are required.

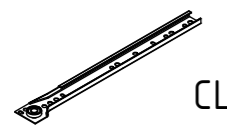
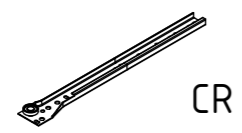
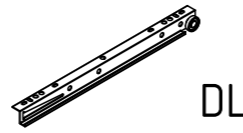
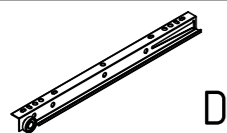
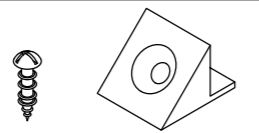
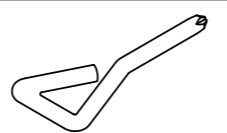
 A $\Phi 15 \times 9.5$ x116+3	 B $\Phi 6.5 \times 35$ x116+3	 C $\Phi 6 \times 30$ x43+2
 D $\Phi 8 \times 30$ x24+3	 E $\Phi 3.5 \times 12$ x48+3	 F $\Phi 4 \times 35$ x20+2
 G L=300 x4	 G L=300 x4	 G L=300 x4
 G L=300 x4	 H x12+1	 I x1

Cam Lock Fastening System

Insert the cam bolt into the hole first, then insert the cam lock and lock it.

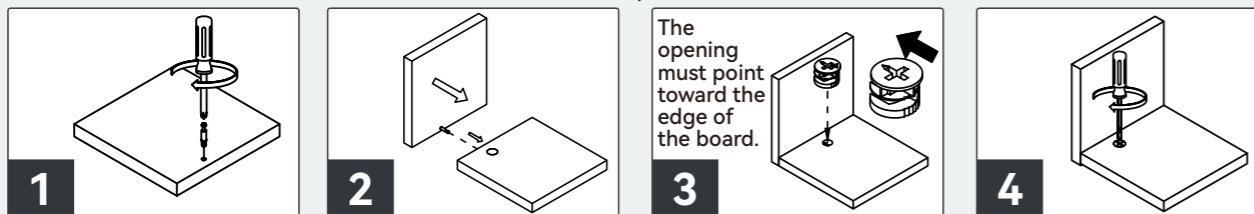

The opening must point toward the edge of the board.

Assembly Instructions

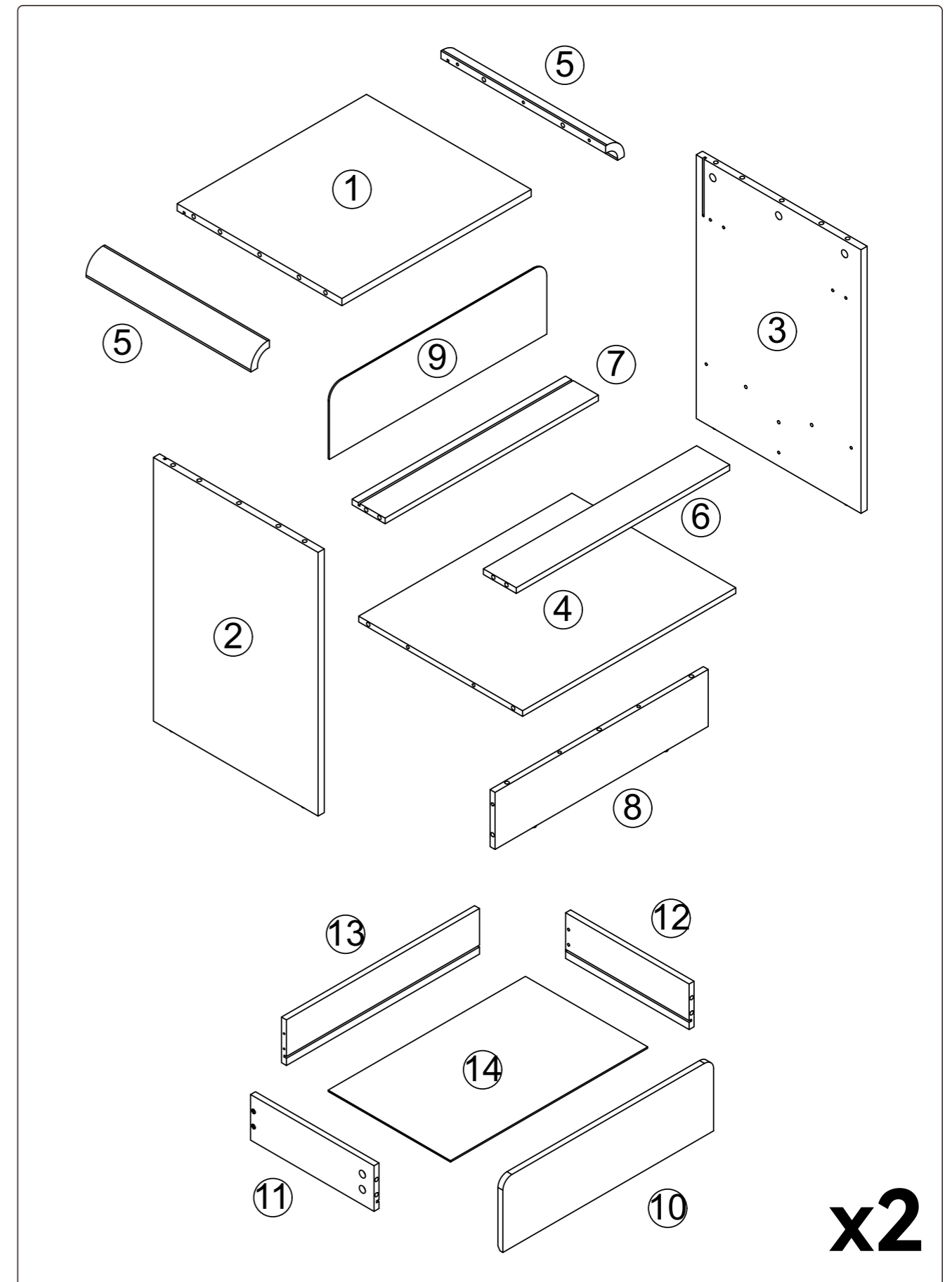

x2

Assembly Instructions

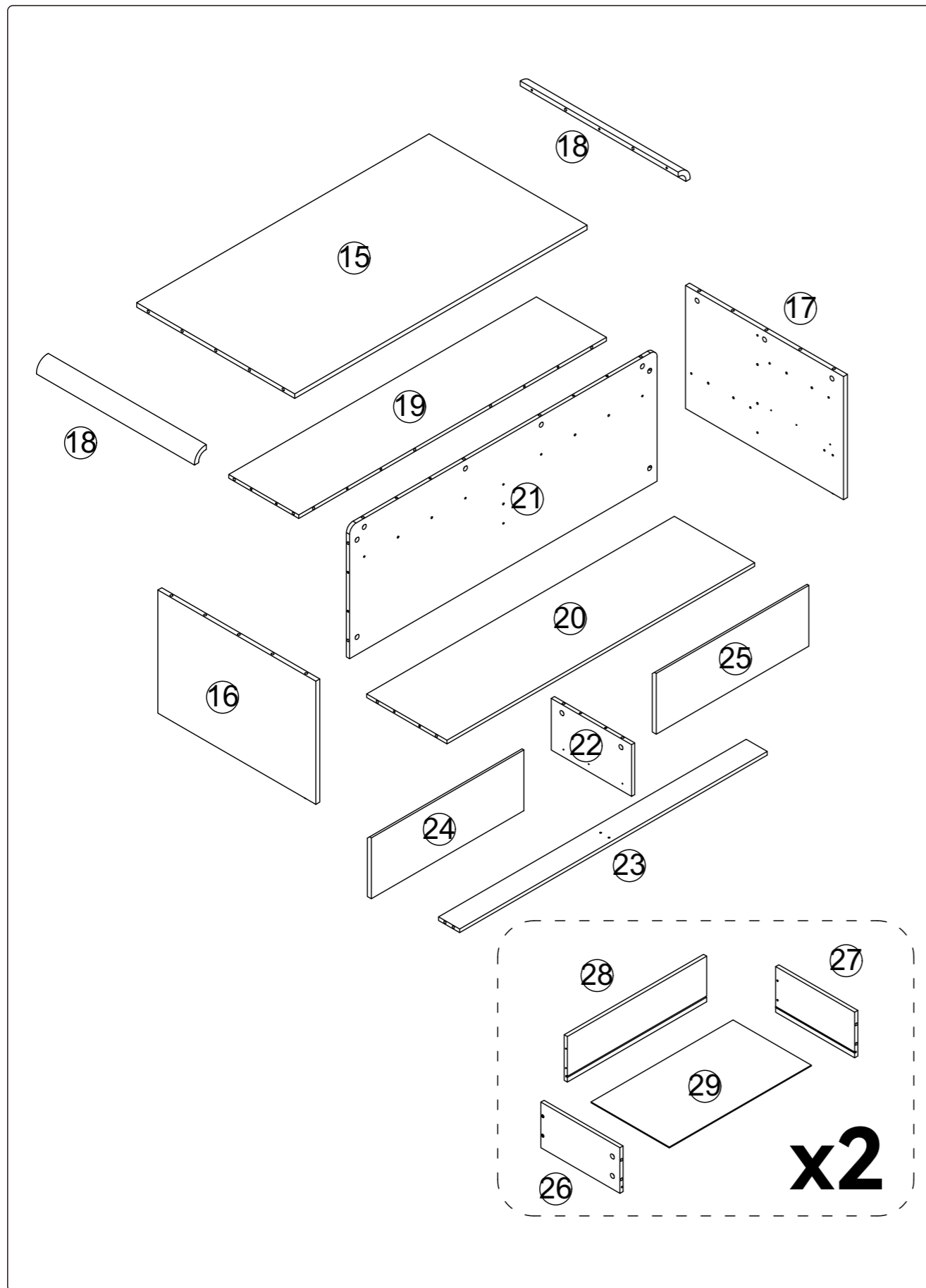

Step 1

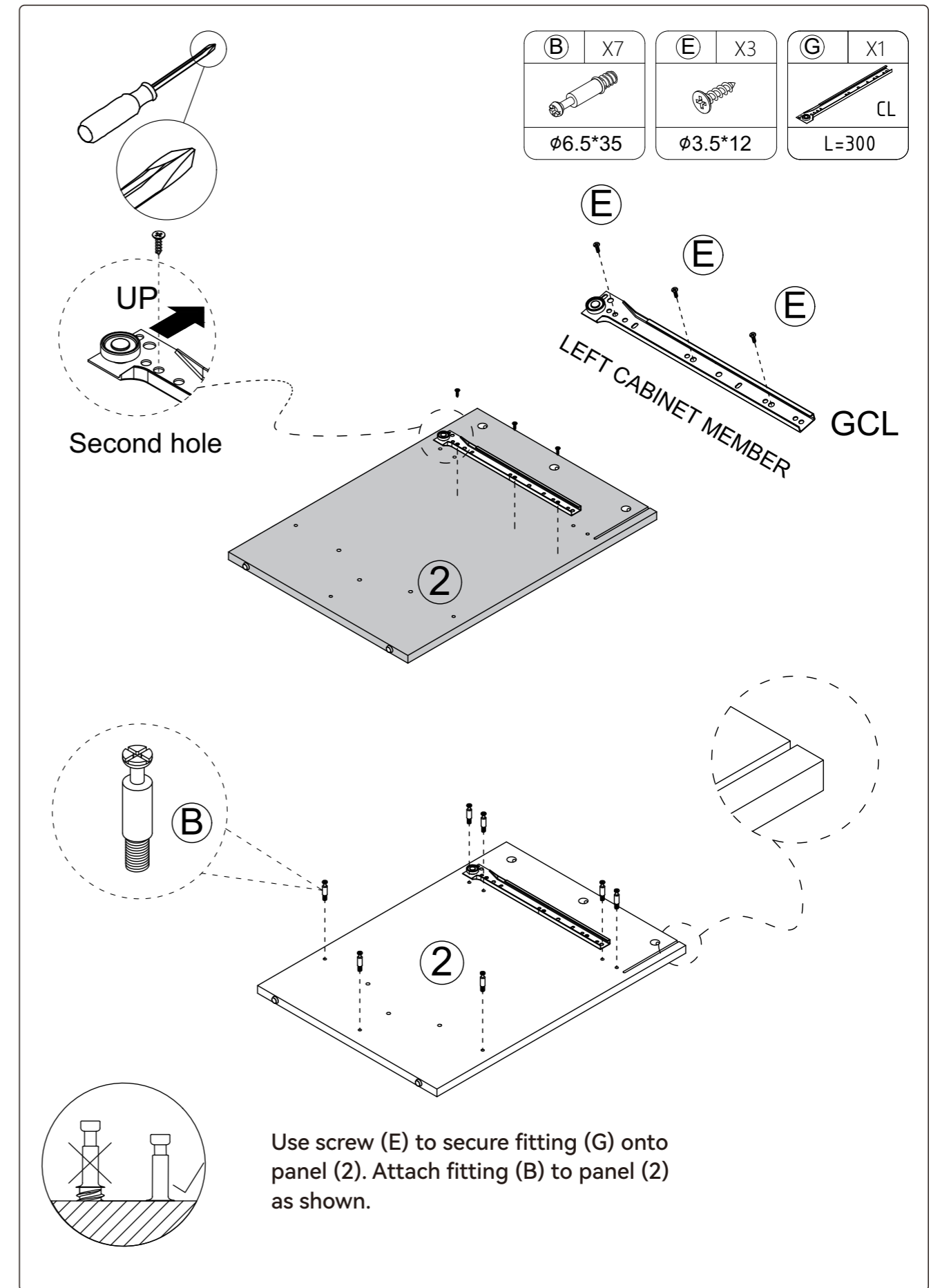

Step 2

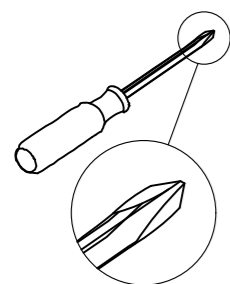

(A)	X3	(B)	X3	(C)	X2
ø15*9.5		ø6.5*35		ø6*30	

Attach fitting (B) to panel (4), then place fitting (C) into the hole of panel (4), align it, and insert panel (8) vertically. Use fitting (A), turning clockwise to secure it to panel (4), as shown.

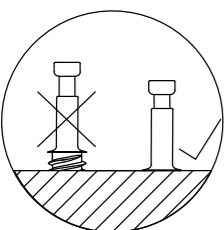
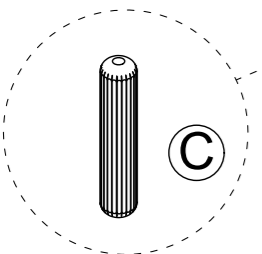
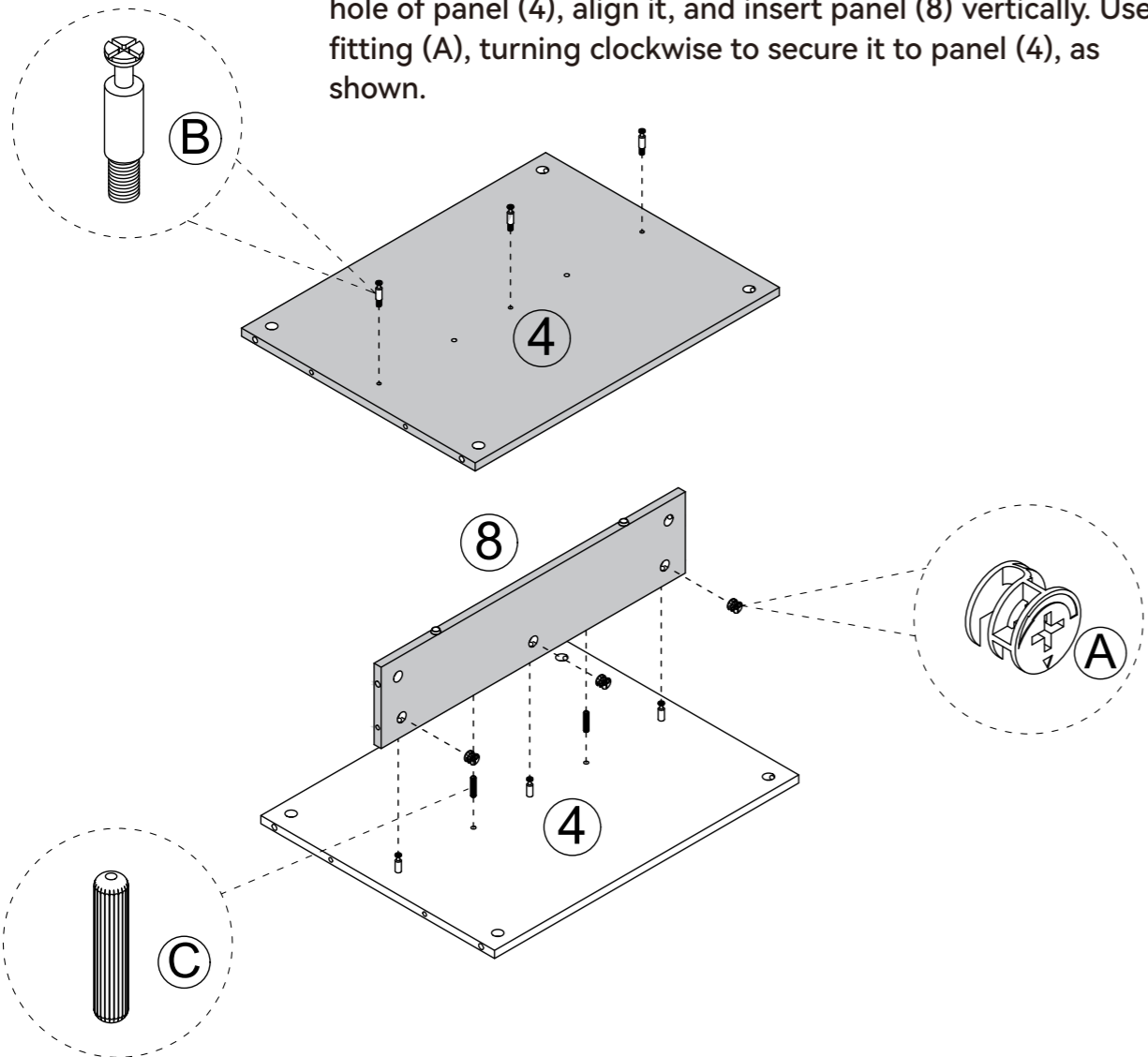

Insert the cam bolt into the hole first, then insert the cam lock and lock it.

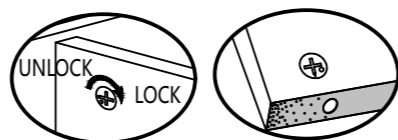

Proper orientation of CAM LOCK

Step 3

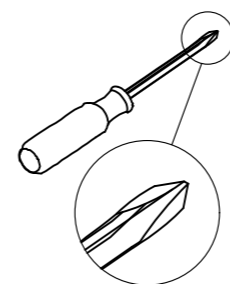

(A)	X7	(C)	X3
ø15*9.5		ø6*30	

Use fitting (A) to connect panels (6), (7), and (2) together. Place fitting (C) into the hole of panel (2), align it, then insert panels (4), (8) vertically. Use fitting (A), turning clockwise to secure them to panel (2), as shown.

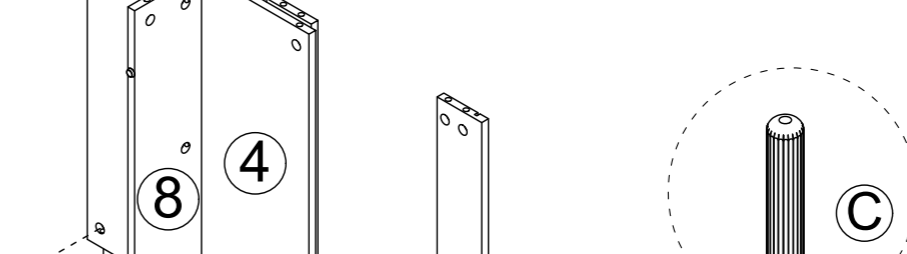
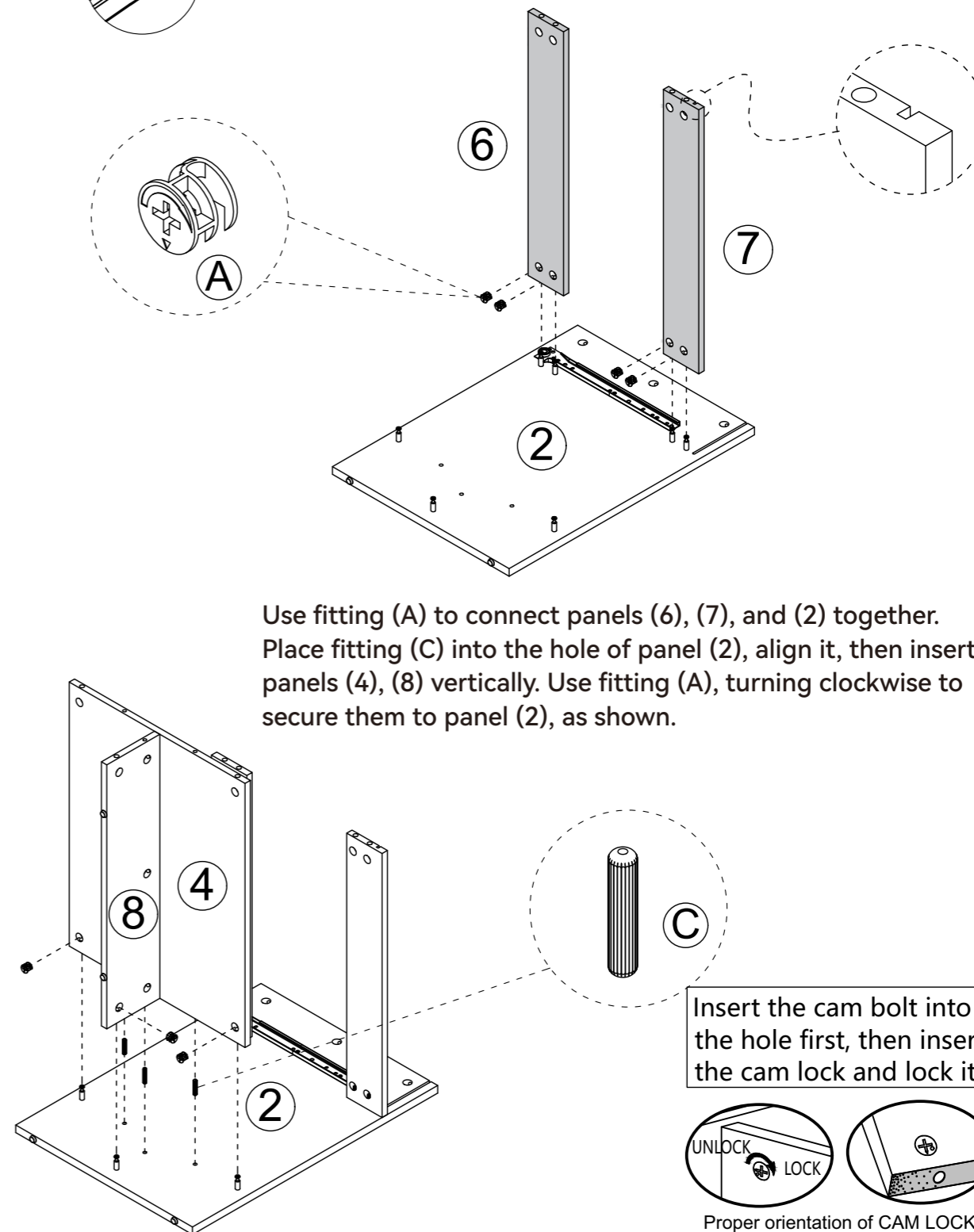

Insert the cam bolt into the hole first, then insert the cam lock and lock it.

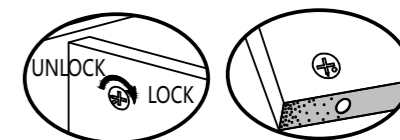

Proper orientation of CAM LOCK

Step 4

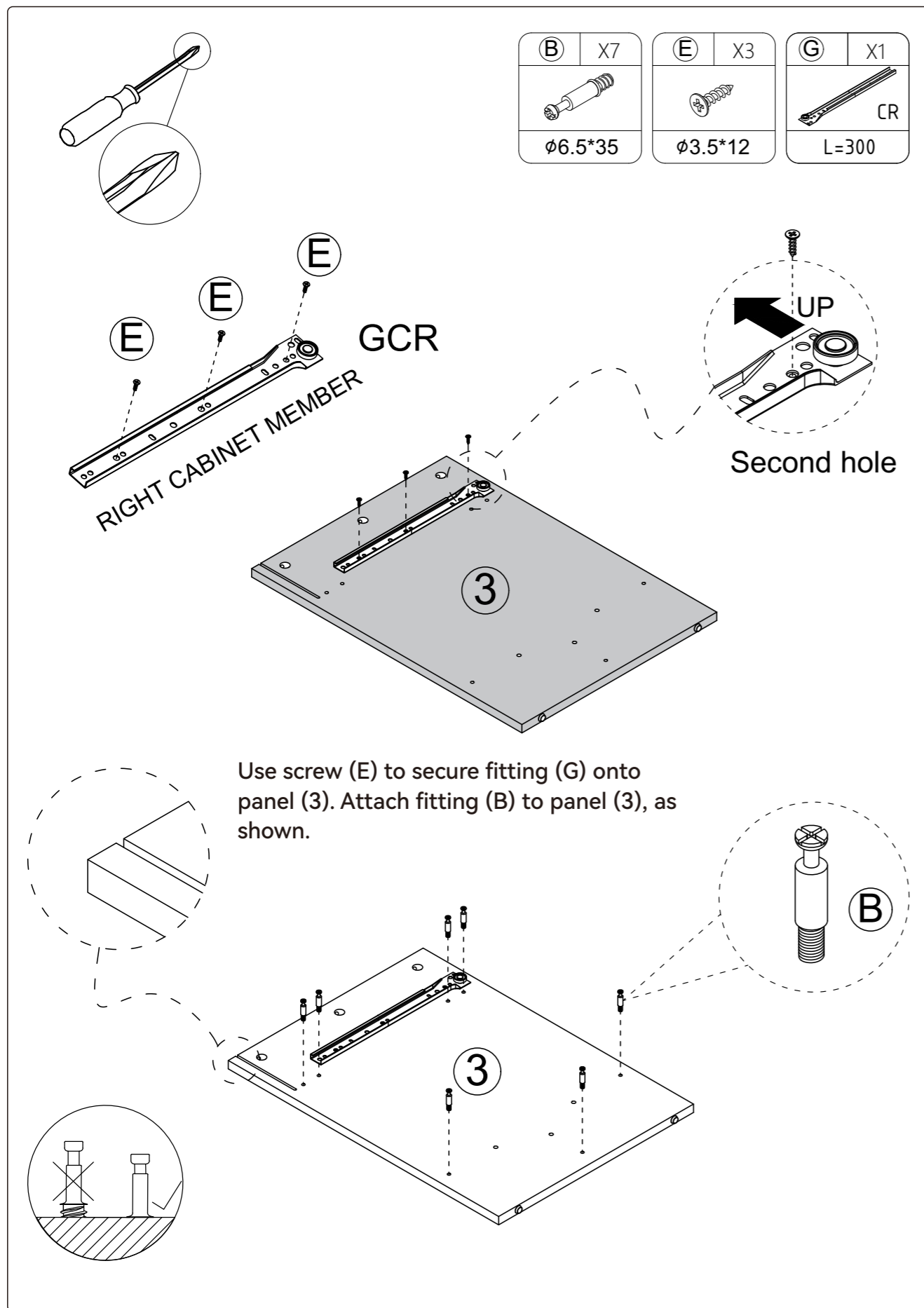

Step 5

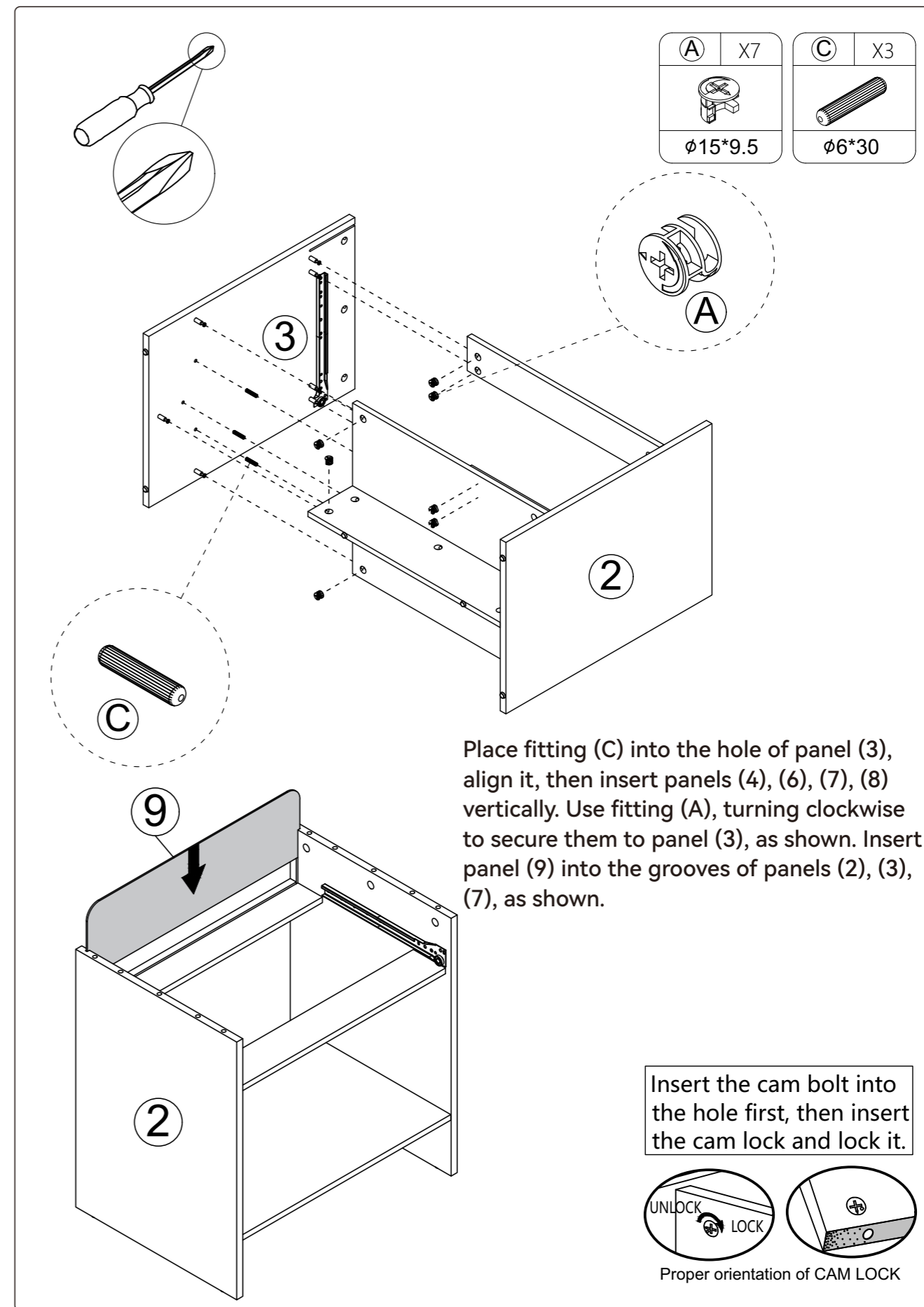

Step 6

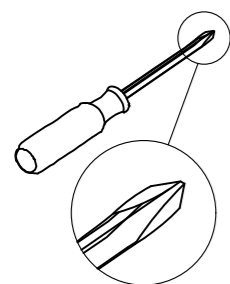

(A)	X6	(B)	X12	(D)	X4
Ø15*9.5		Ø6.5*35		Ø8*30	

Attach fitting (B) to panel (5), as shown. Place fitting (D) into the hole of panel (1), align it, and insert panel (5) vertically. Use fitting (A), turning clockwise to secure it to panel (1), as shown.

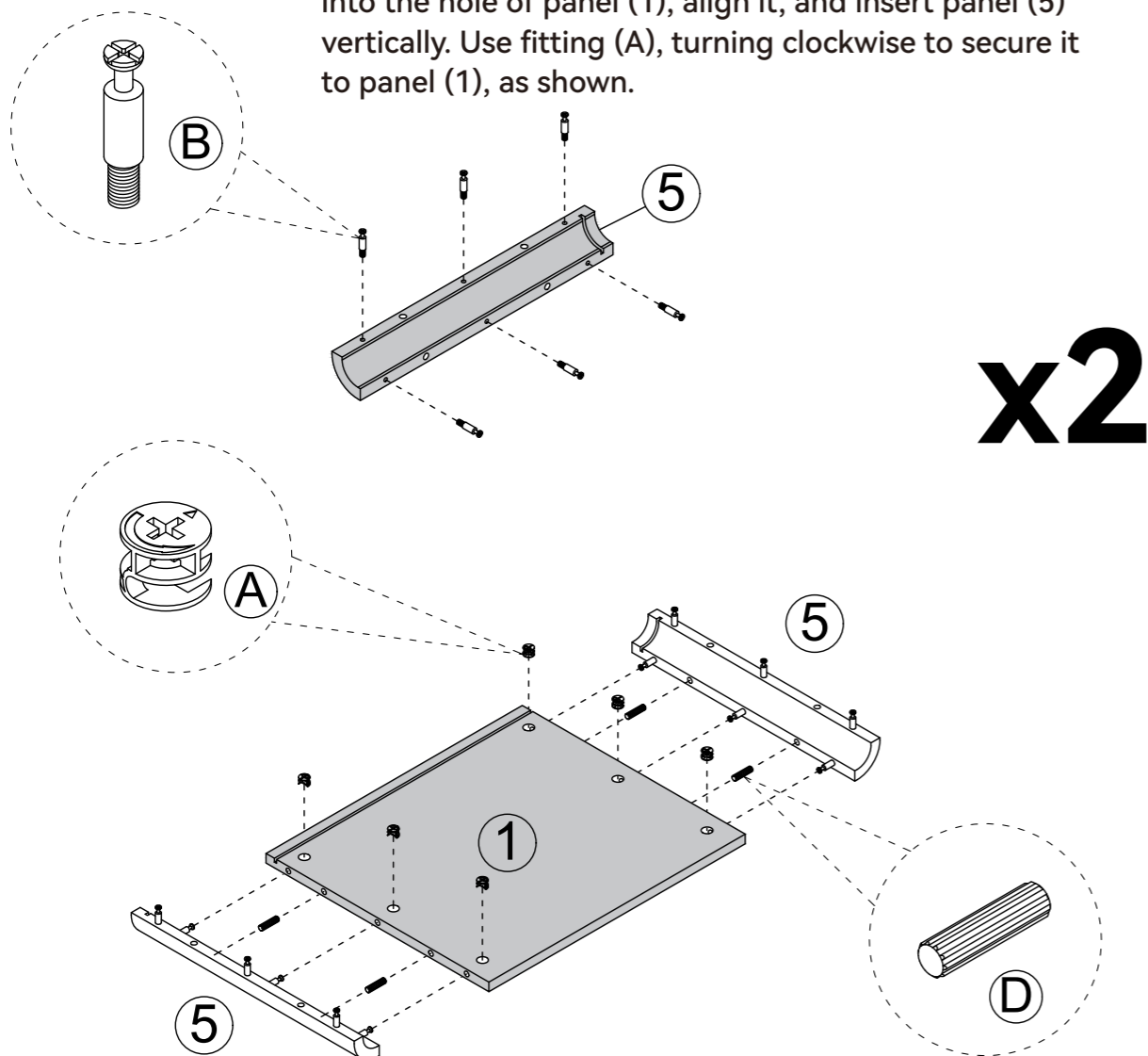

Insert the cam bolt into the hole first, then insert the cam lock and lock it.

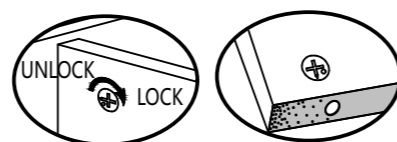
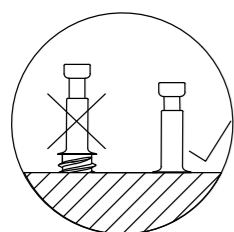

Proper orientation of CAM LOCK

Step 7

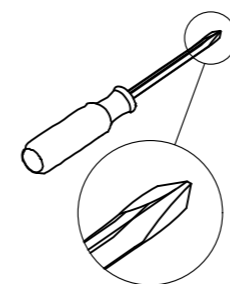

(A)	X6	(D)	X4
Ø15*9.5		Ø8*30	



The slot is on the back side here.

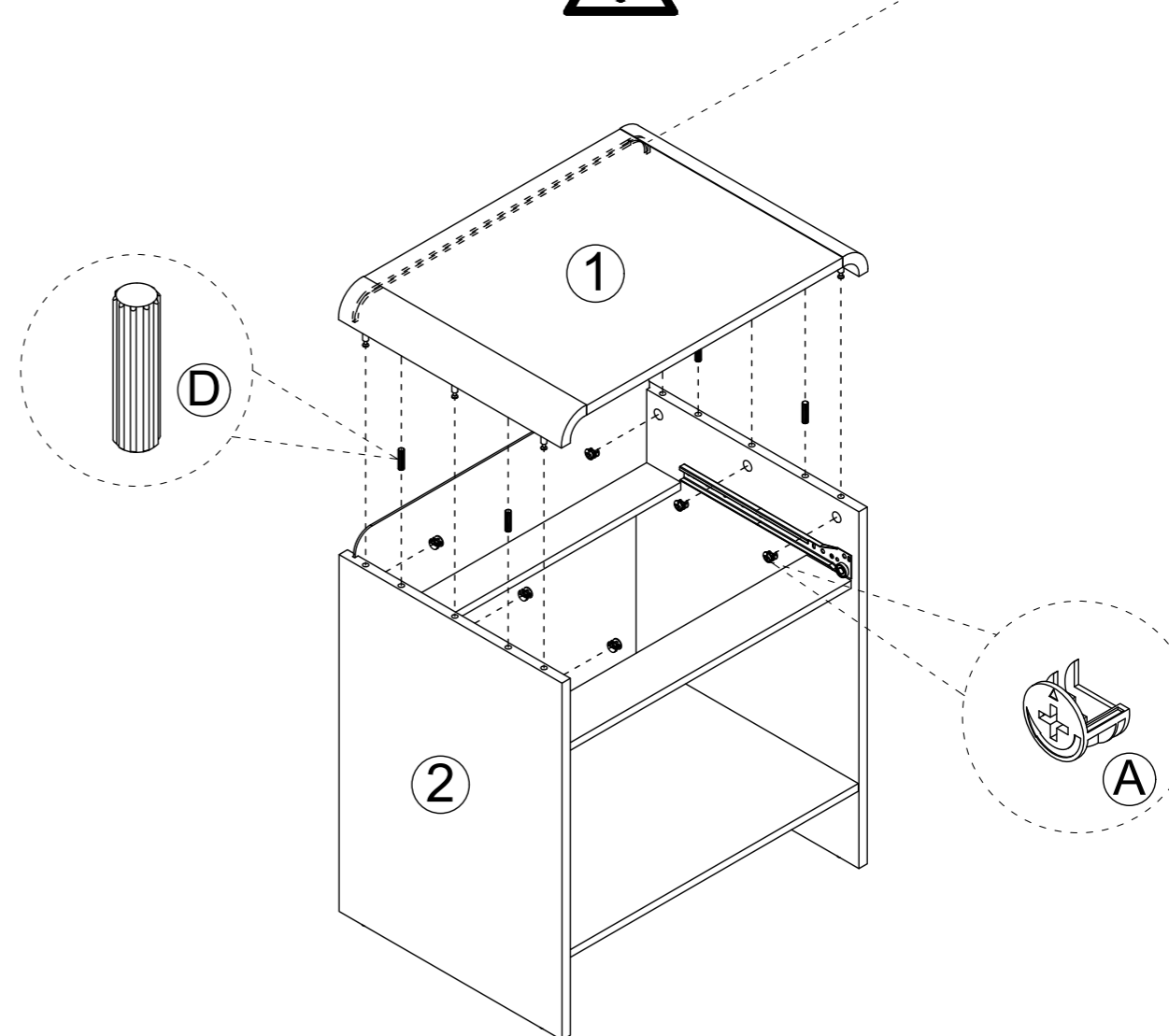

Place fitting (D) into the holes of panels (2), (3), align them, then insert panels (1) and (5) vertically. Use fitting (A), turning clockwise to secure them to panels (2), (3), as shown.

Insert the cam bolt into the hole first, then insert the cam lock and lock it.

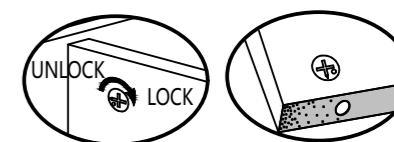

Proper orientation of CAM LOCK

Step 8

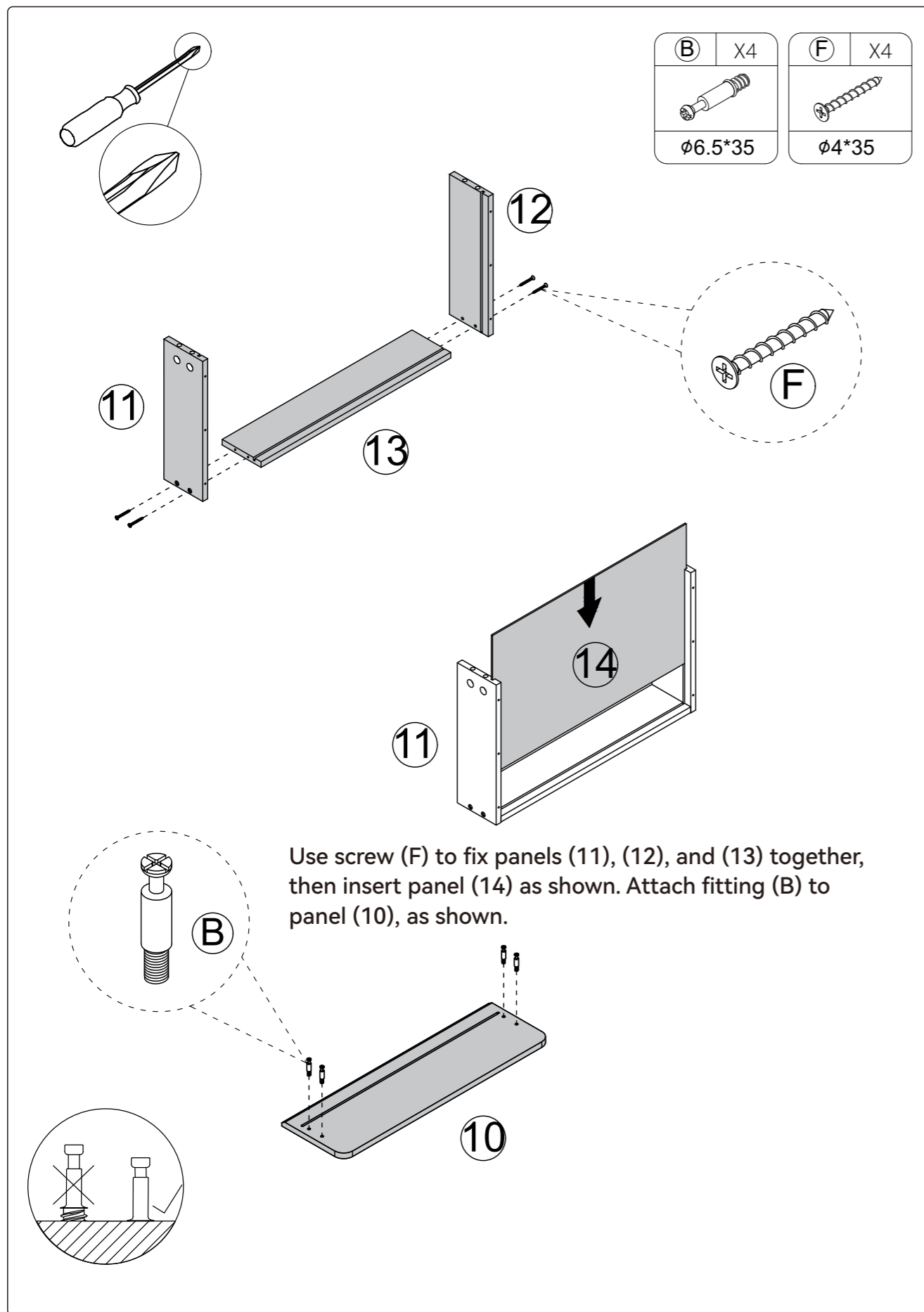

Step 9

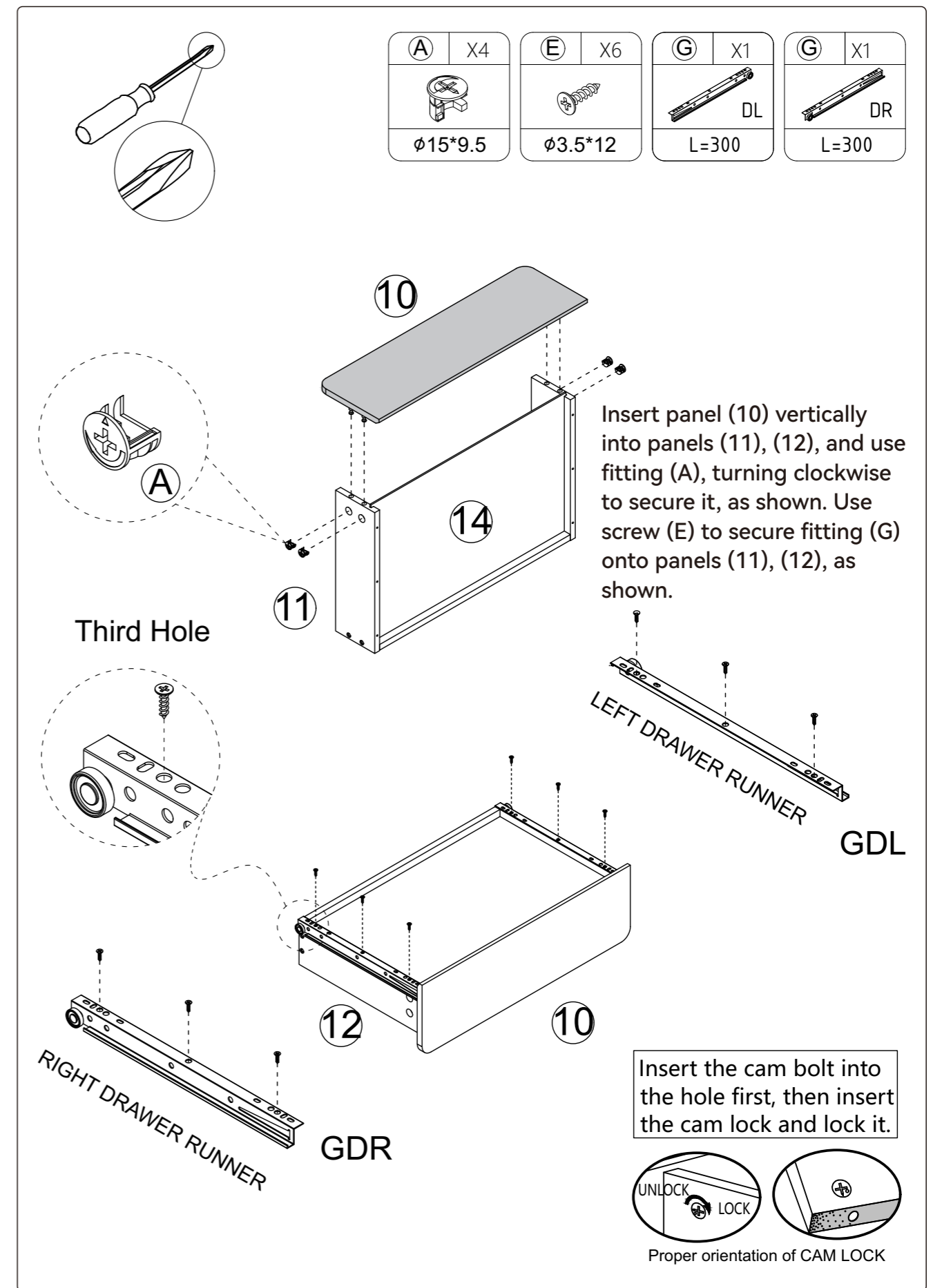

Step 10

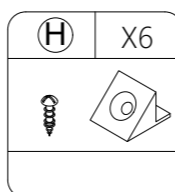
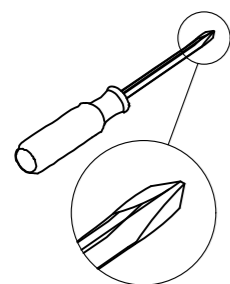

Push panel (10) into the cabinet, aligning it with fitting (G) slots. Turn to the back, and use fitting (H) to better secure panel (9), as shown.

Cabinet Slide

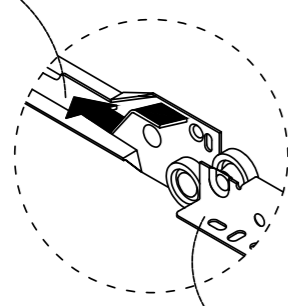

Drawer Slide

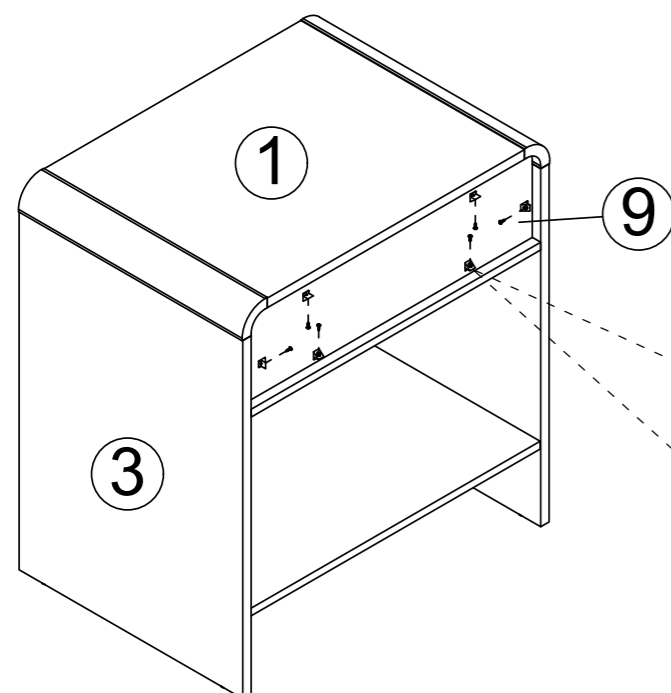
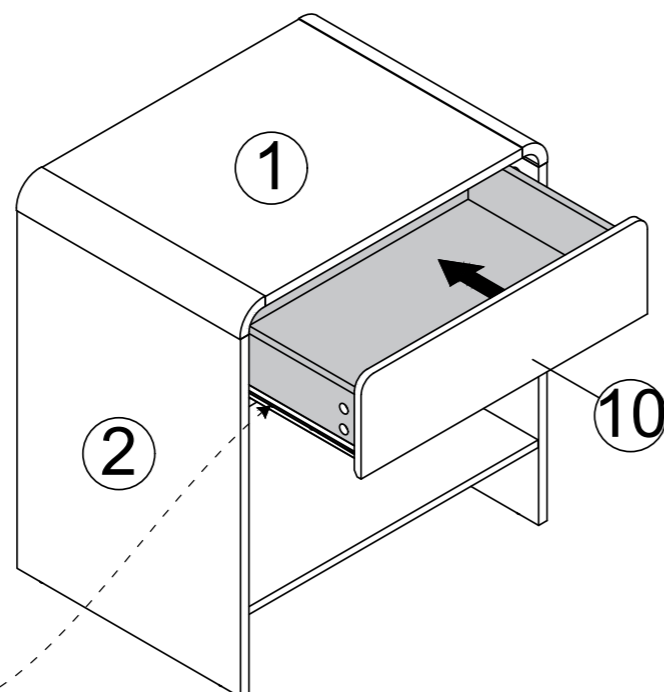

Insert the plastic buckle into the back plate slot, screw through the hole in the plastic buckle and lock it in place.

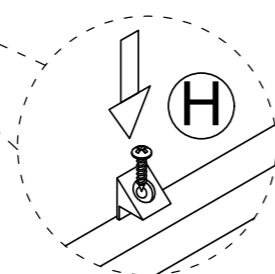

Step 11

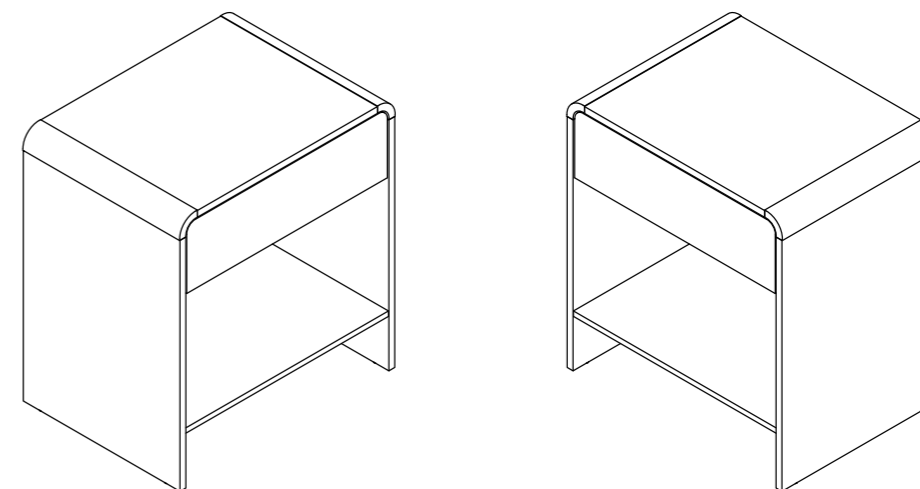
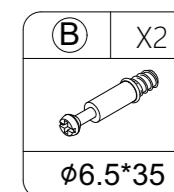
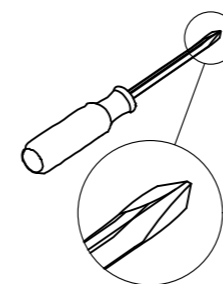

After installation is complete, repeat the above steps.

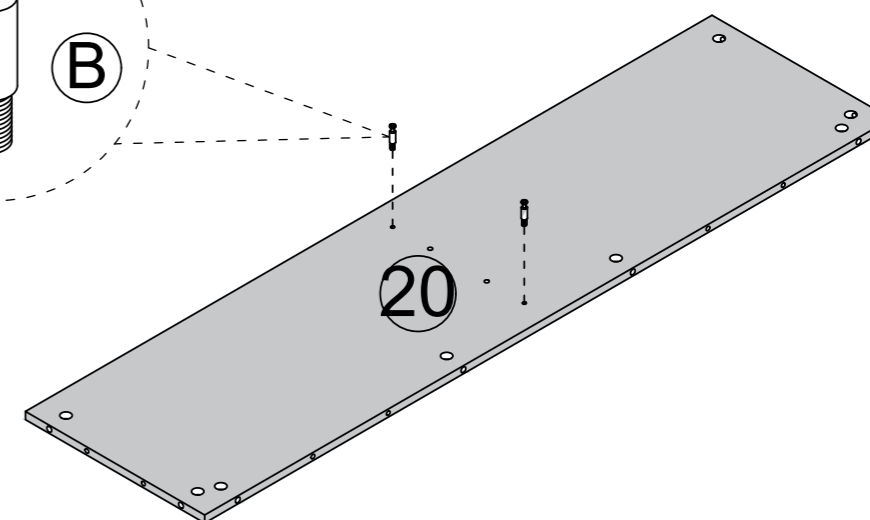
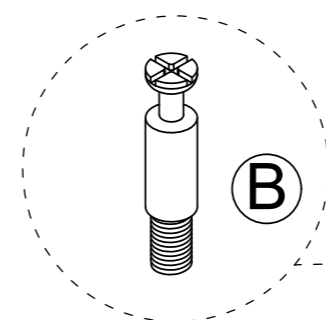

Once one is installed, repeat the above steps for the second one. Attach fitting (B) to panel (20), as shown.

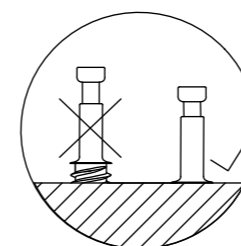

Step 12

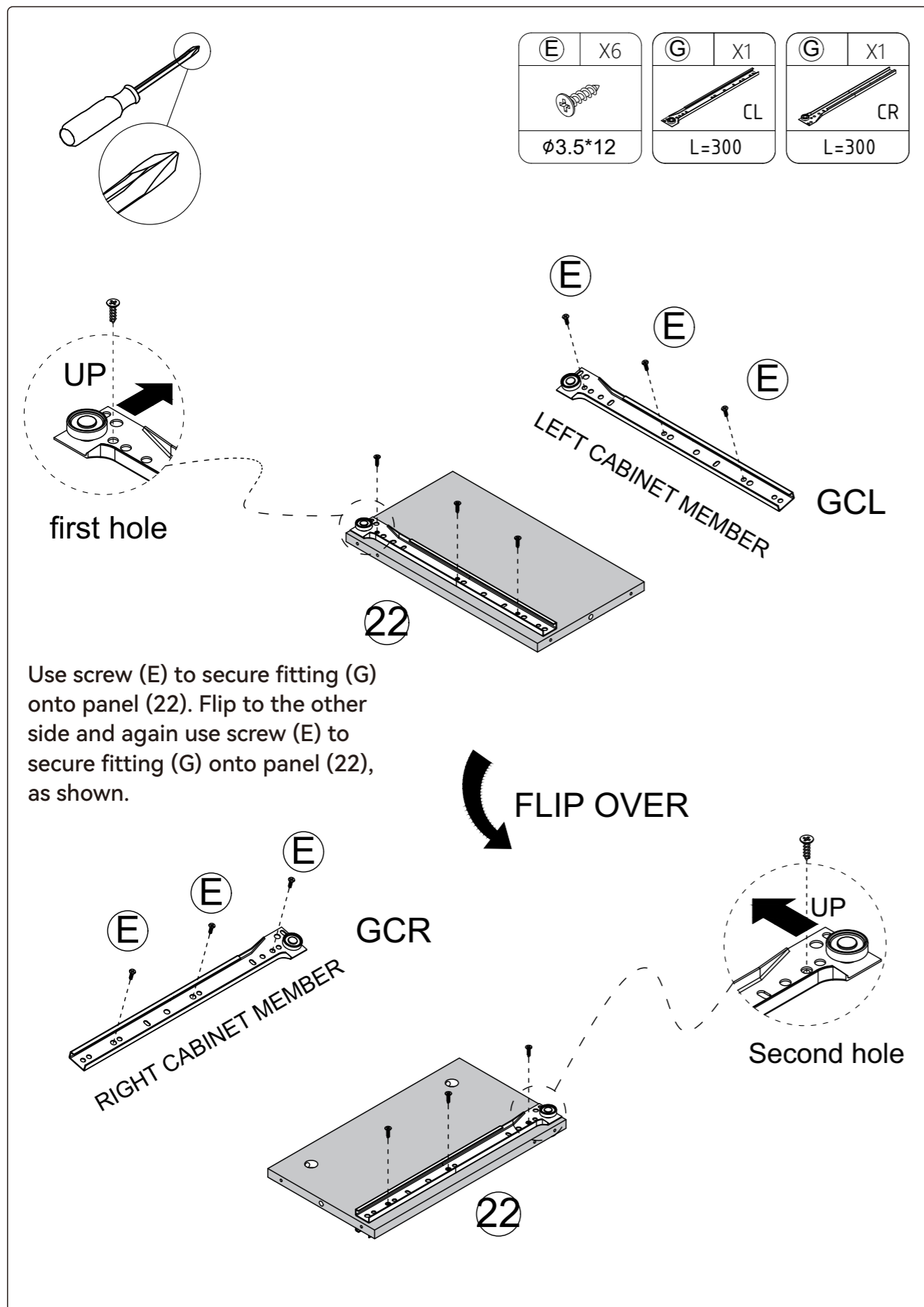

Step 13

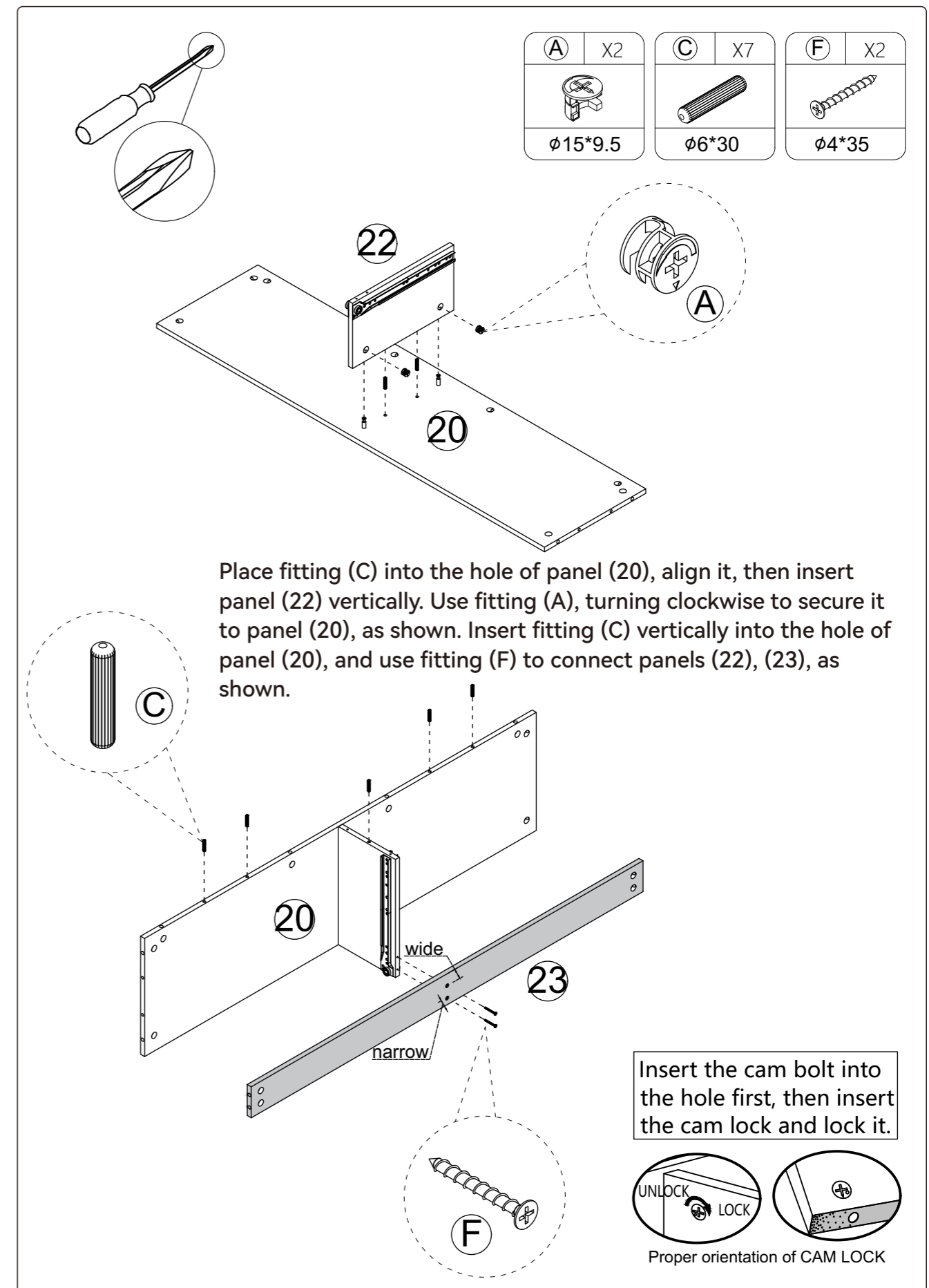

Step 14

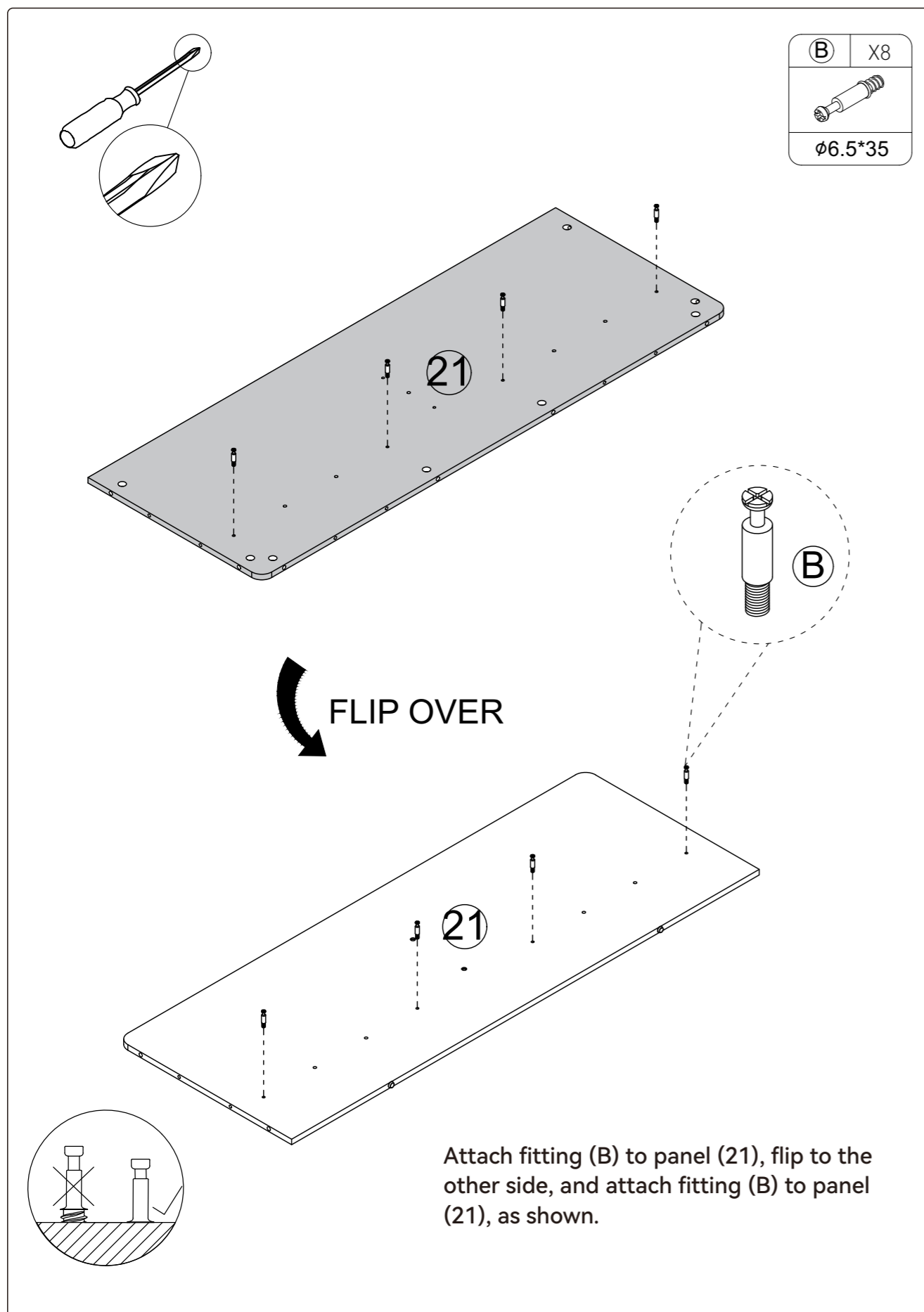

Step 15

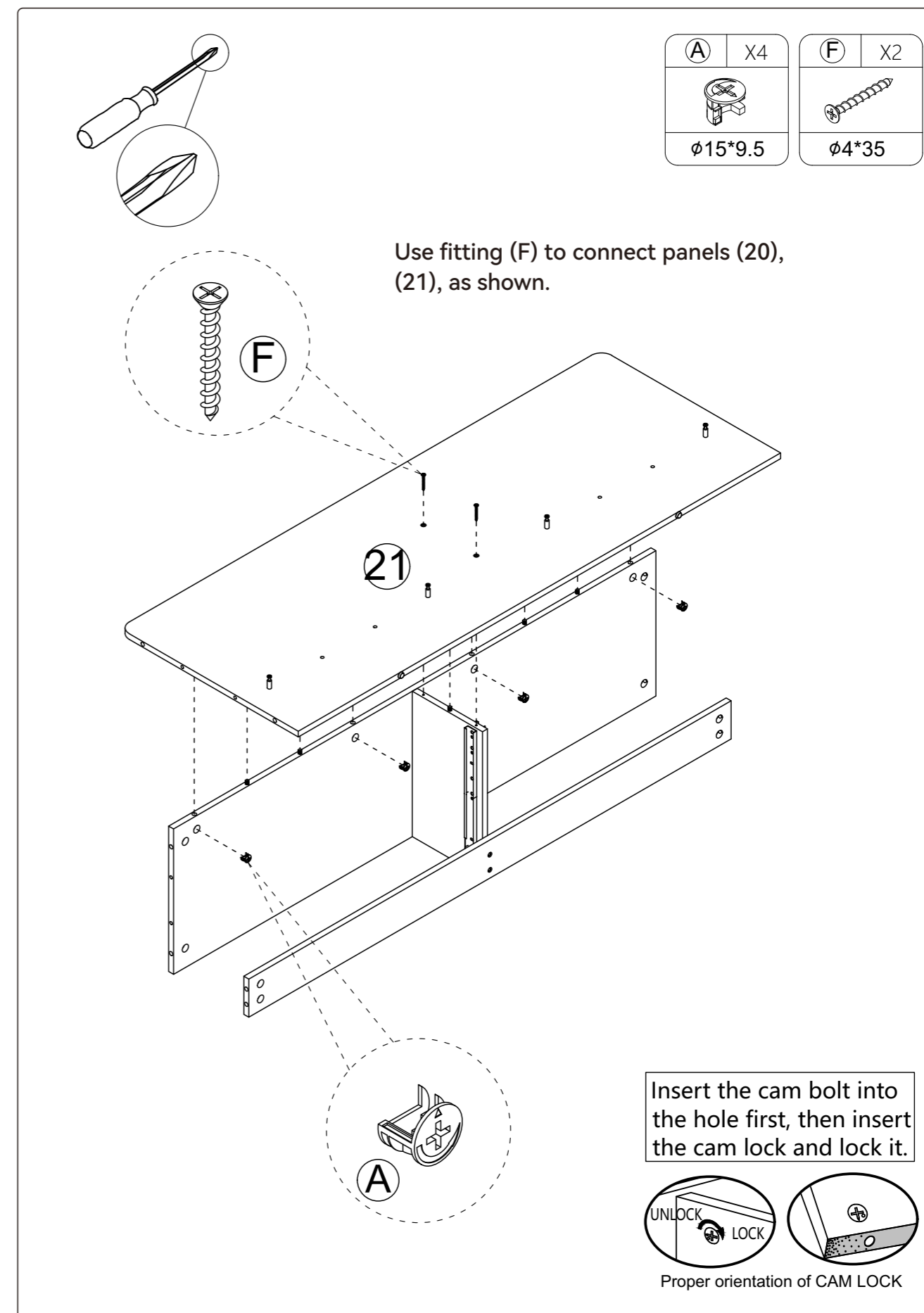

Step 16

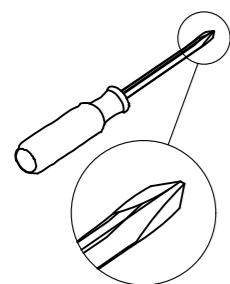

(A)	X4	(C)	X4
Ø15*9.5		Ø6*30	

Place fitting (C) into the hole of panel (21), align it, then insert panel (19) vertically. Use fitting (A), turning clockwise to secure it to panel (21), as shown.

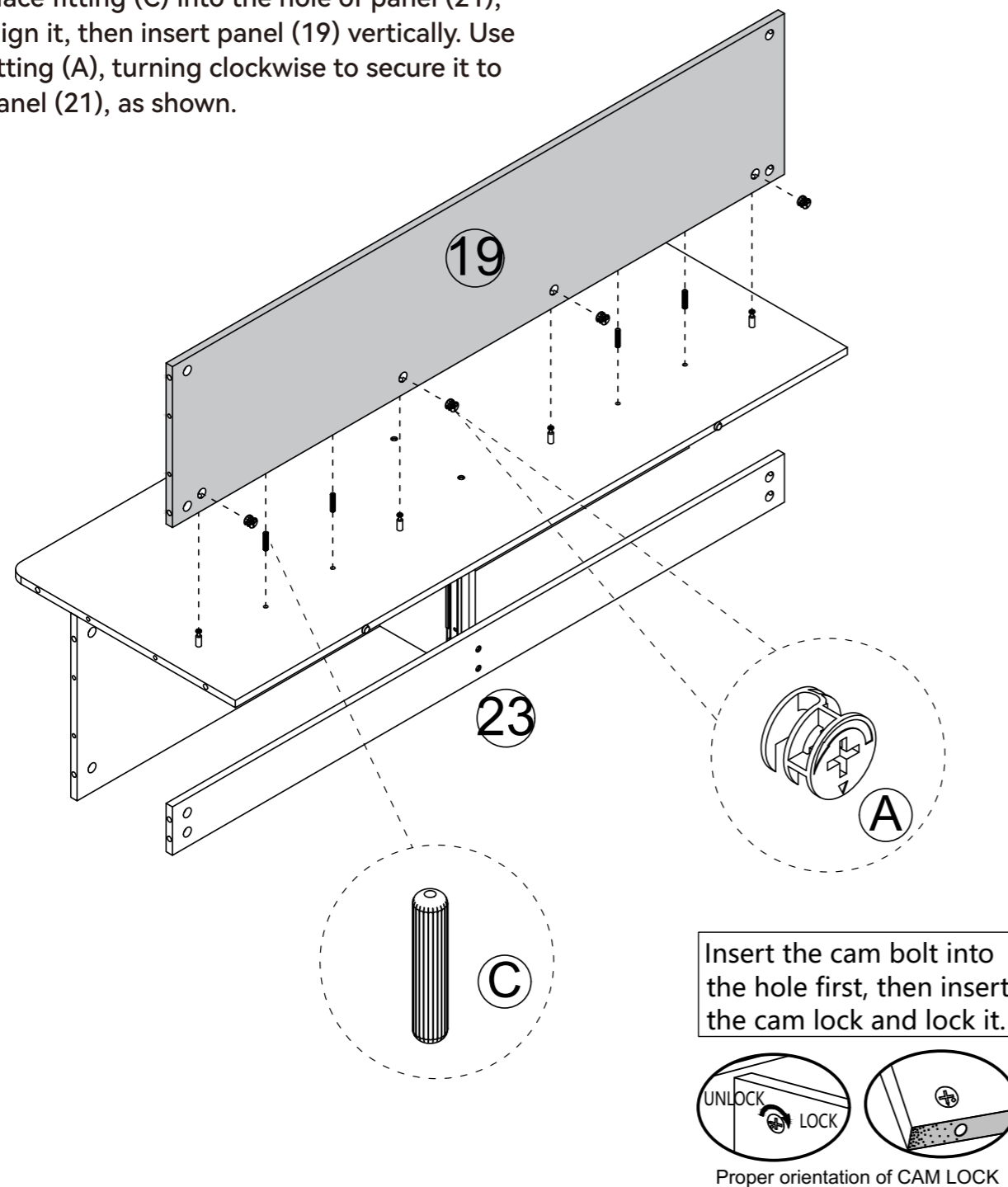

Step 17

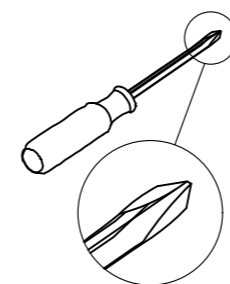

(B)	X8	(E)	X3	(G)	X1
					CL
Ø6.5*35		Ø3.5*12		L=300	

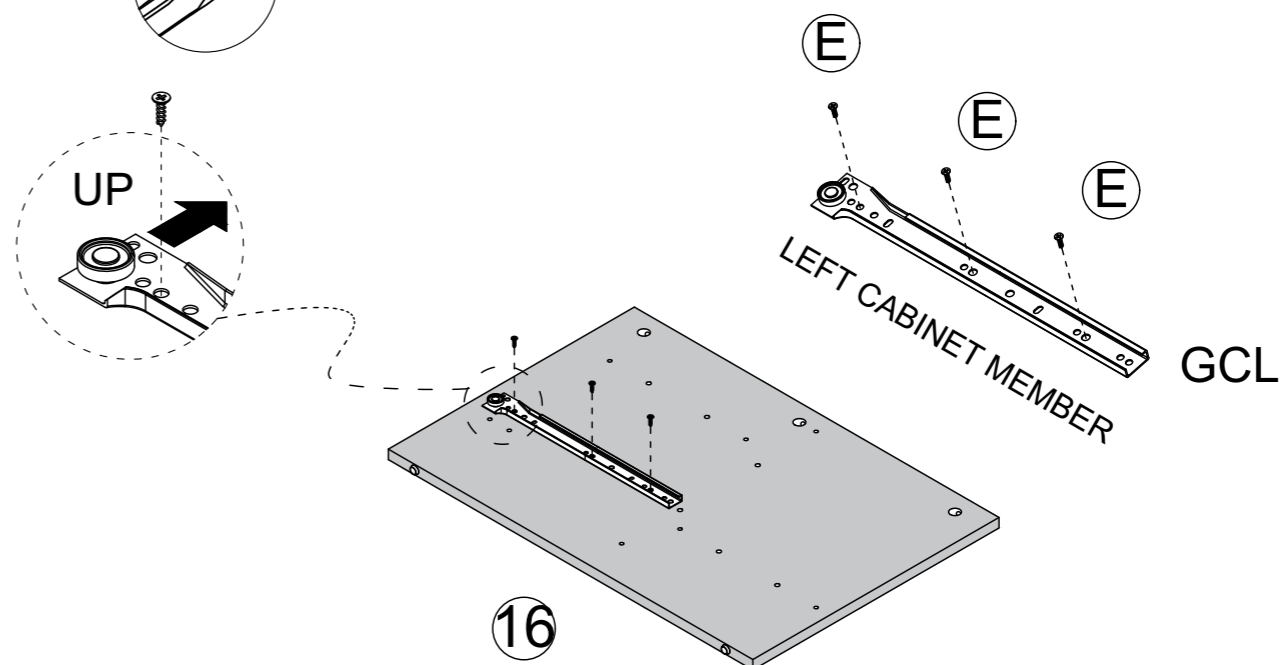

Use screw (E) to secure fitting (G) onto panel (16). Attach fitting (B) to panel (16), as shown.

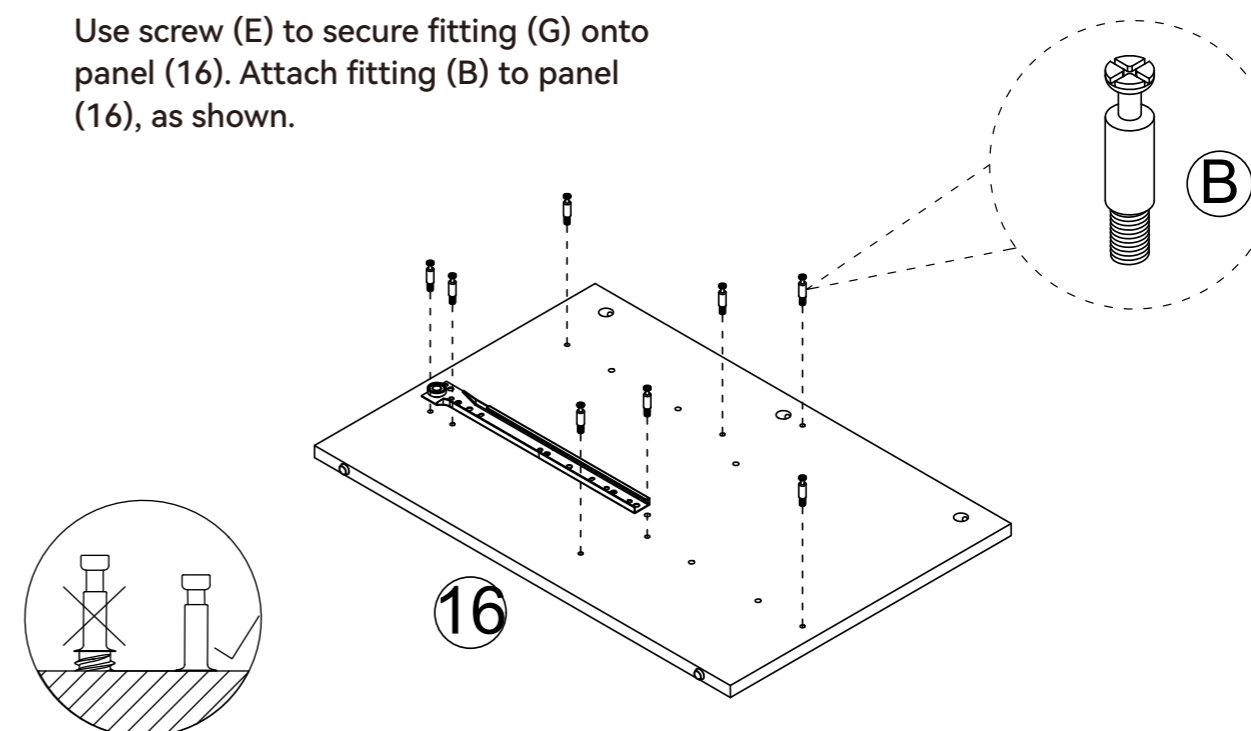

Step 18

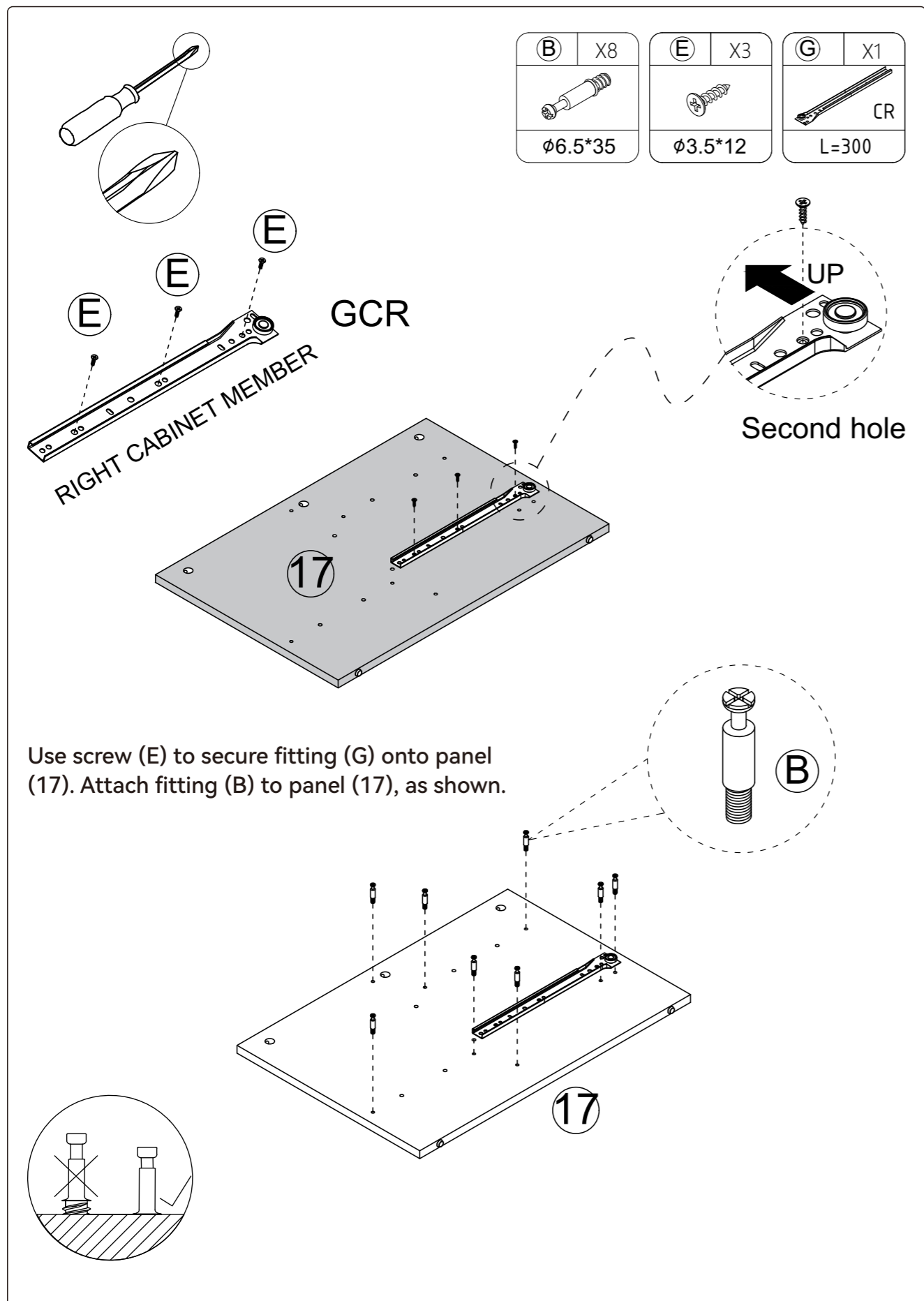

Step 19

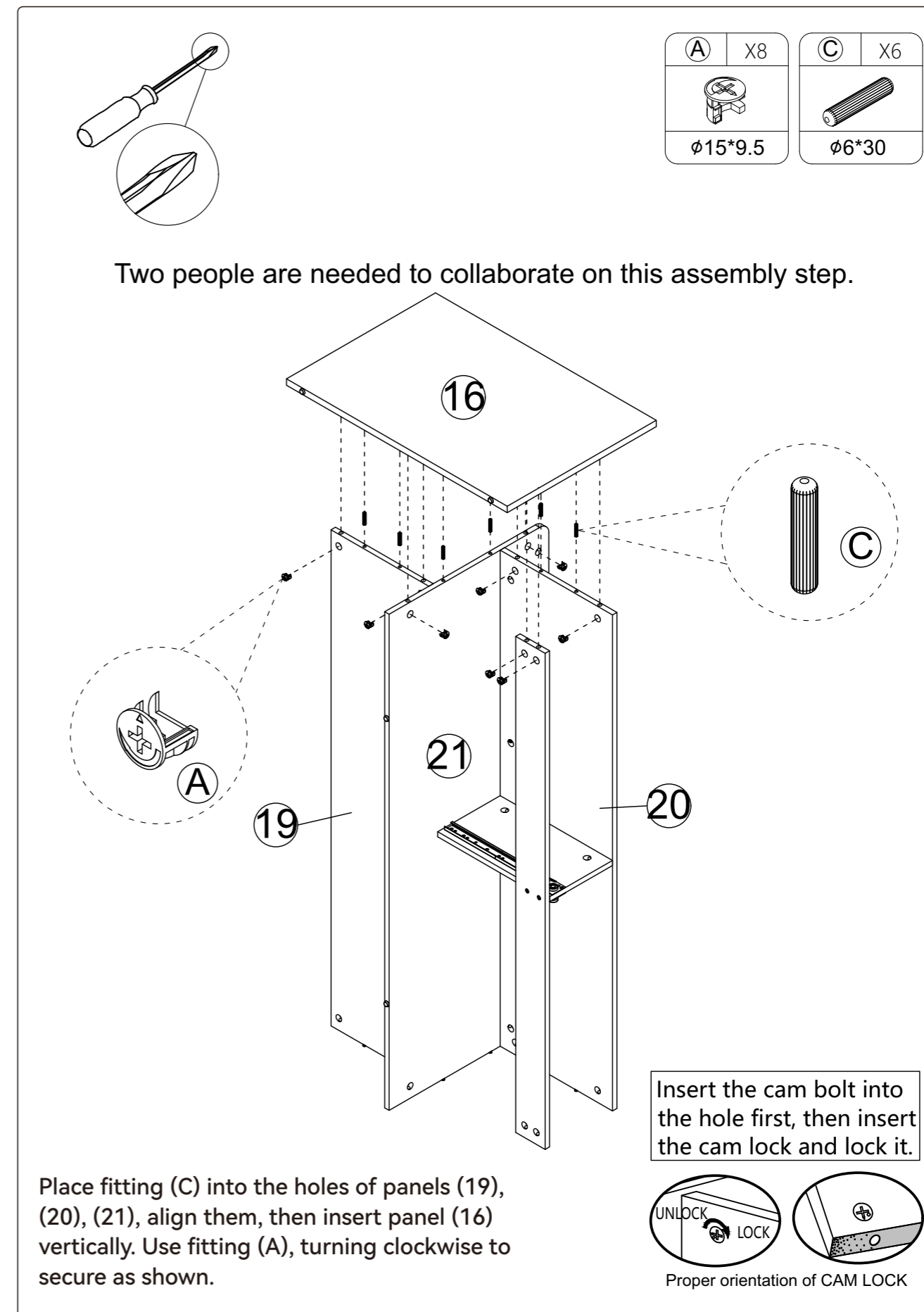

Step 20

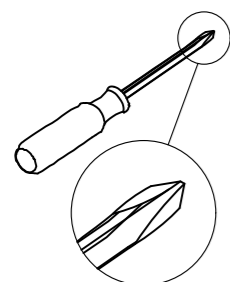

A	X8	C	X6
Ø15*9.5		Ø6*30	

Two people are needed to collaborate on this assembly step.

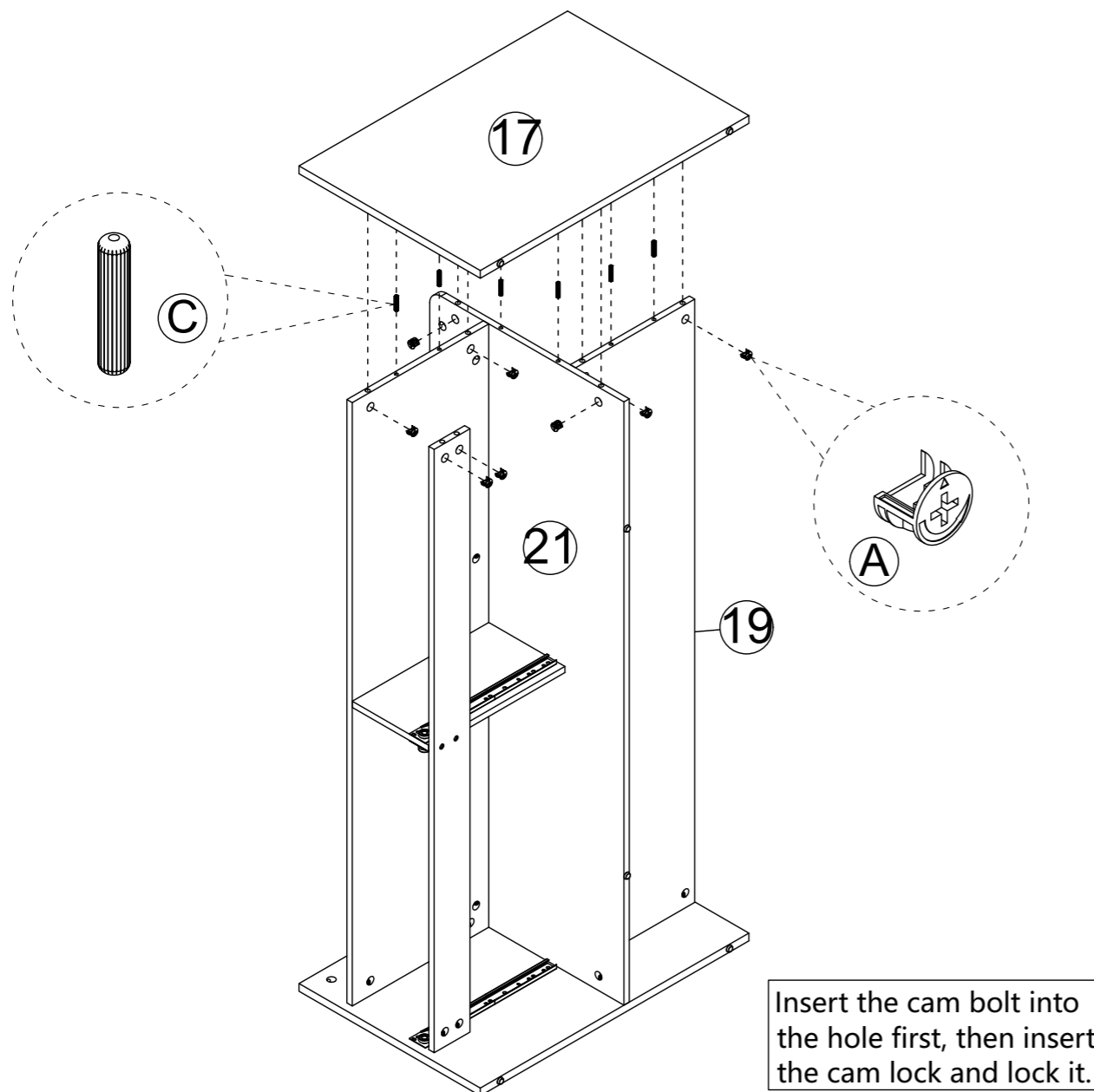

Place fitting (C) into the holes of panels (19), (20), (21), align them, then insert panel (17) vertically. Use fitting (A), turning clockwise to secure as shown.

Insert the cam bolt into the hole first, then insert the cam lock and lock it.

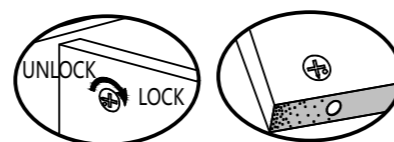

Proper orientation of CAM LOCK

Step 21

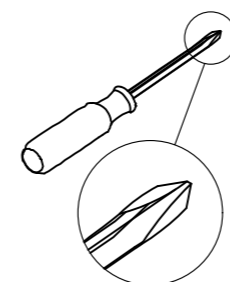

B	X16
Ø6.5*35	

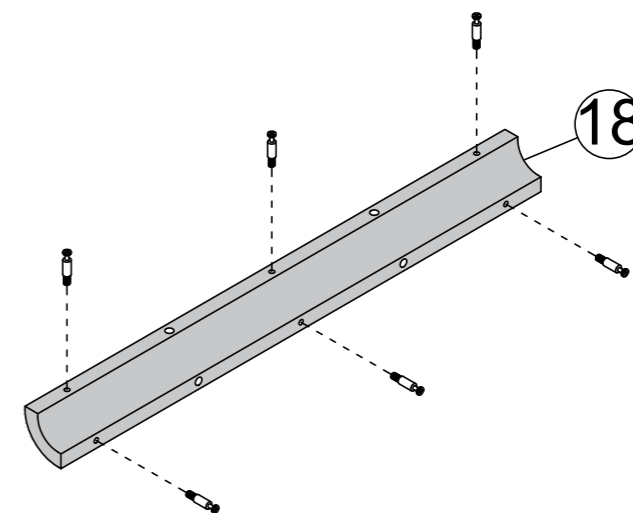

x2

Attach fitting (B) to panel (18), as shown.
Attach fitting (B) to panel (15), as shown.

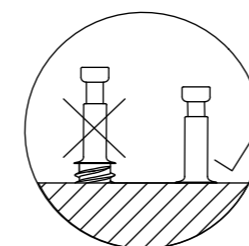
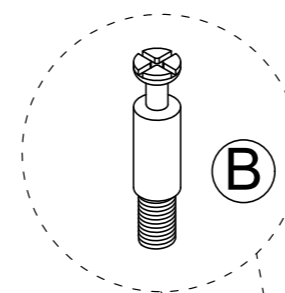

Step 22

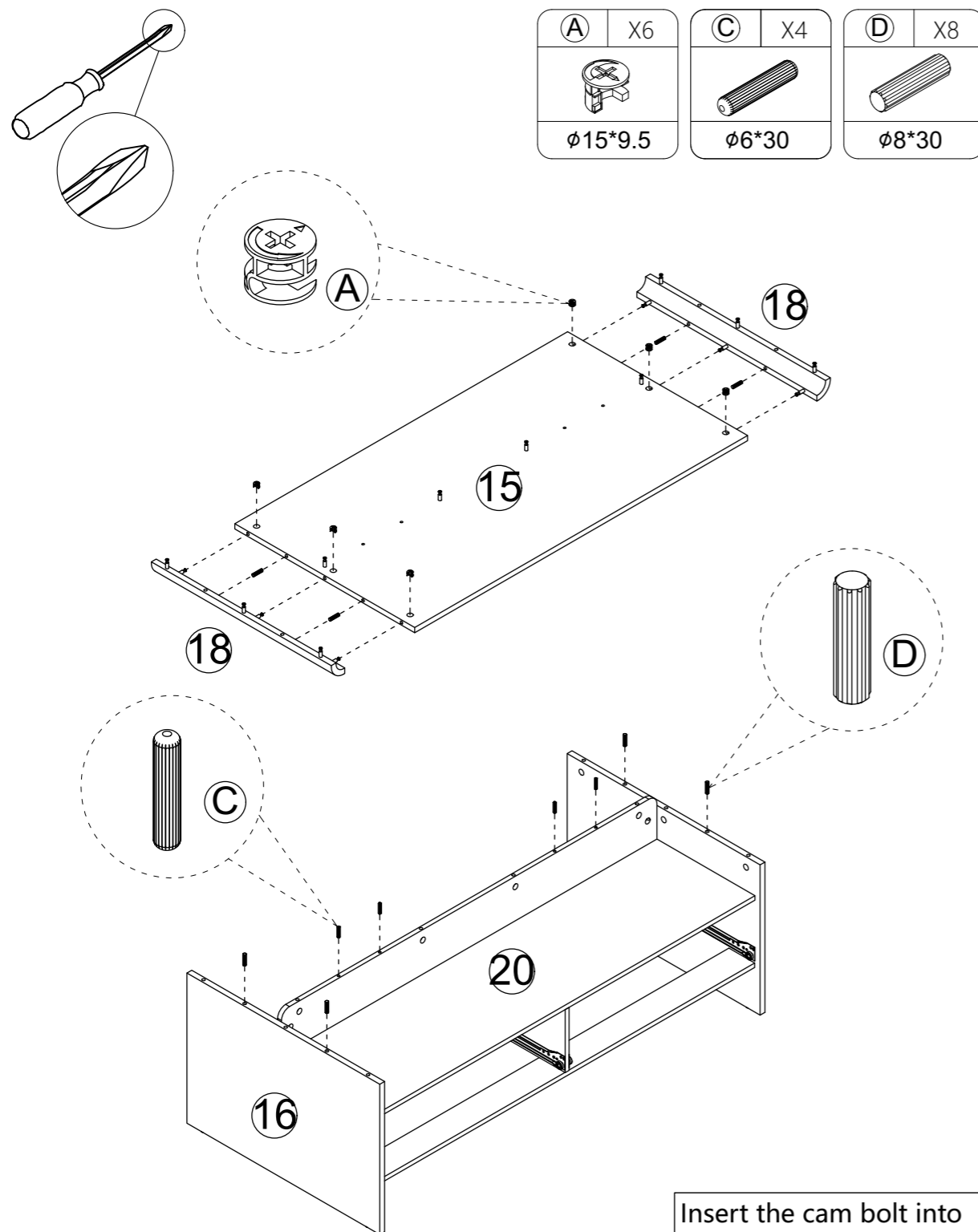

Place fitting (D) into the hole of panel (15), align it, then insert panel (18) vertically. Use fitting (A), turning clockwise to secure it, as shown. Insert fitting (C) vertically into the hole of panel (21), and insert fitting (D) vertically into the holes of panels (16), (17), as shown.

Insert the cam bolt into the hole first, then insert the cam lock and lock it.

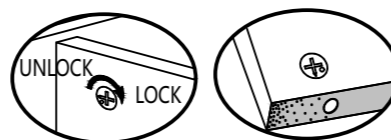

Proper orientation of CAM LOCK

Step 23

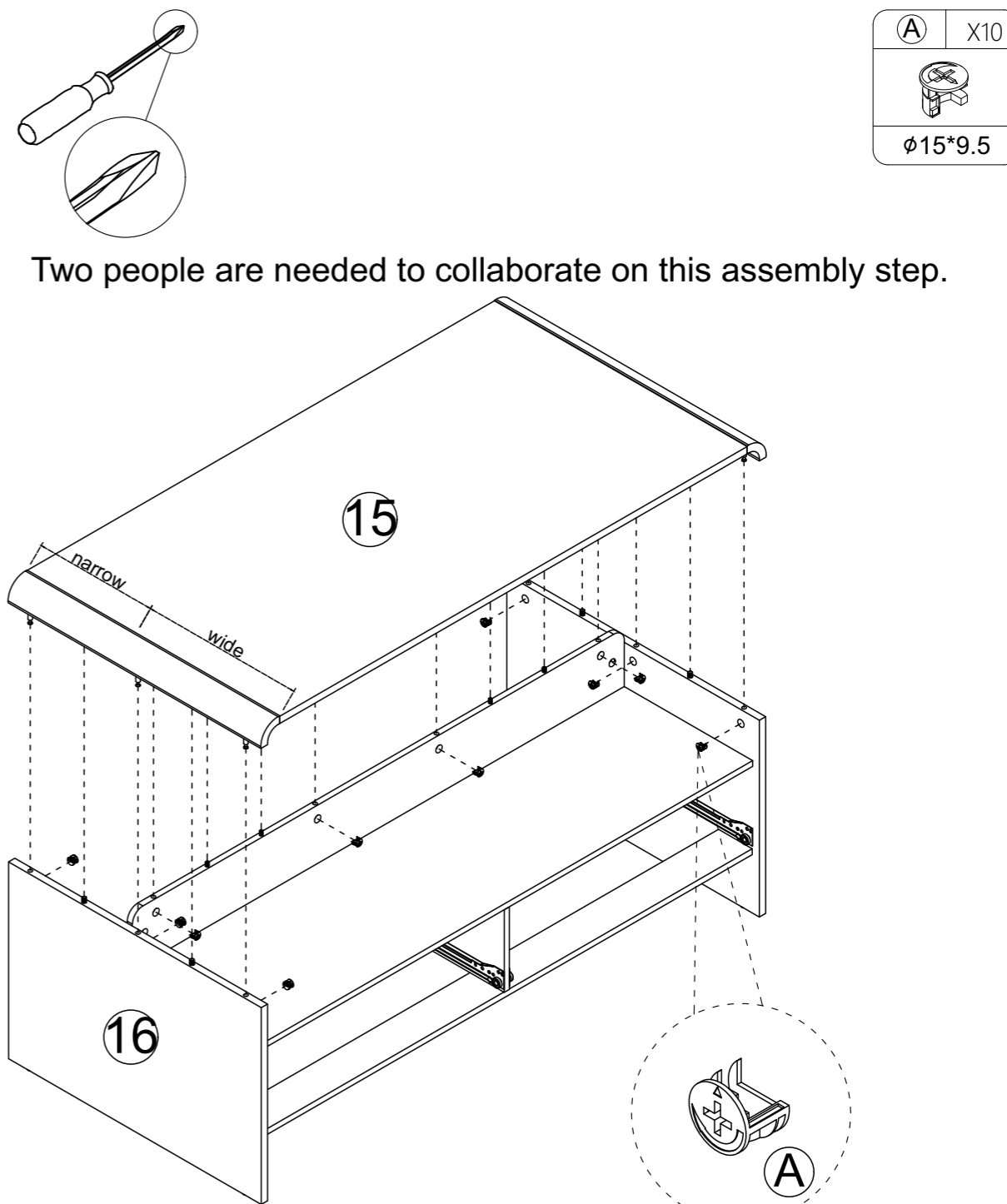

Two people are needed to collaborate on this assembly step.

Insert panel (18) vertically into panels (16), (17), (21), and use fitting (A), turning clockwise to secure, as shown.

Insert the cam bolt into the hole first, then insert the cam lock and lock it.

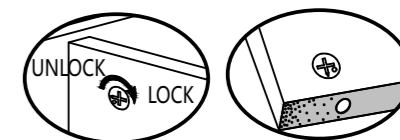

Proper orientation of CAM LOCK

Step 24

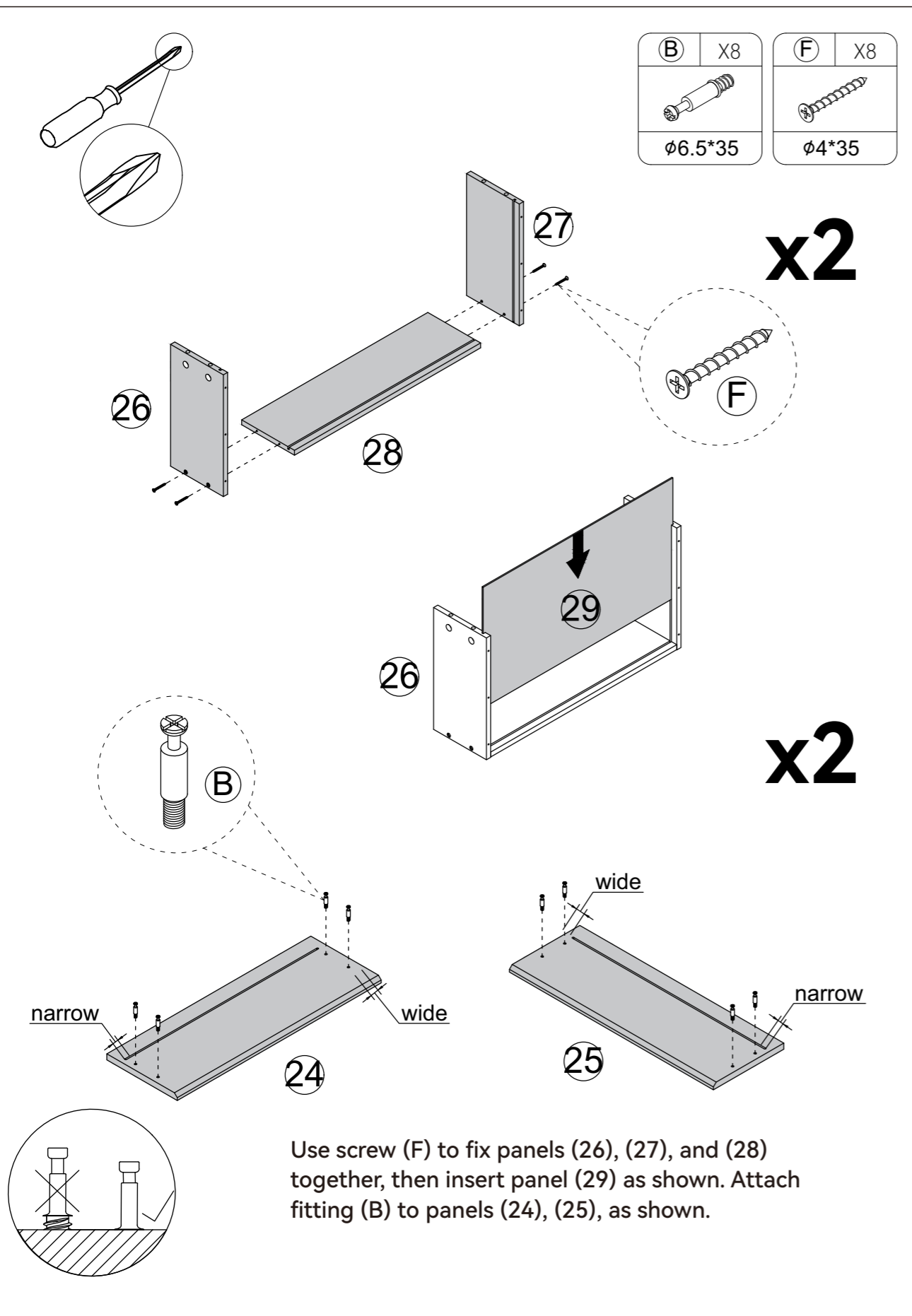

Step 25

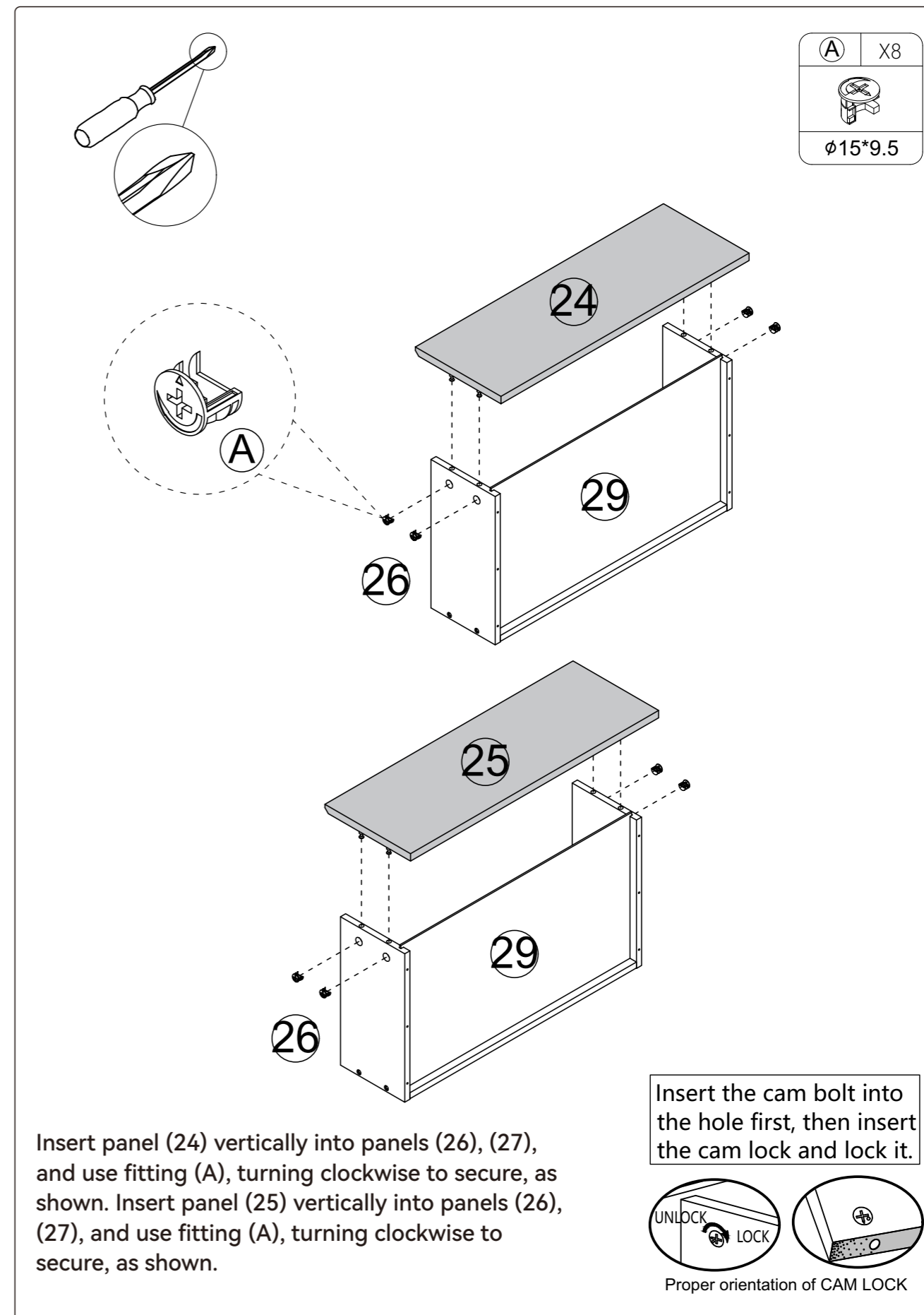

Step 26

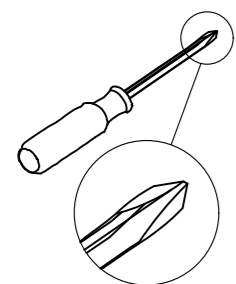

Third Hole

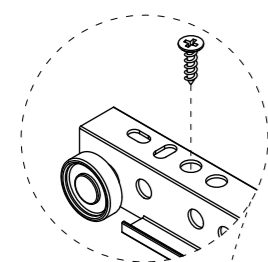

(E)	X12	(G)	X2	(G)	X2
			DL		DR
∅3.5*12		L=300		L=300	

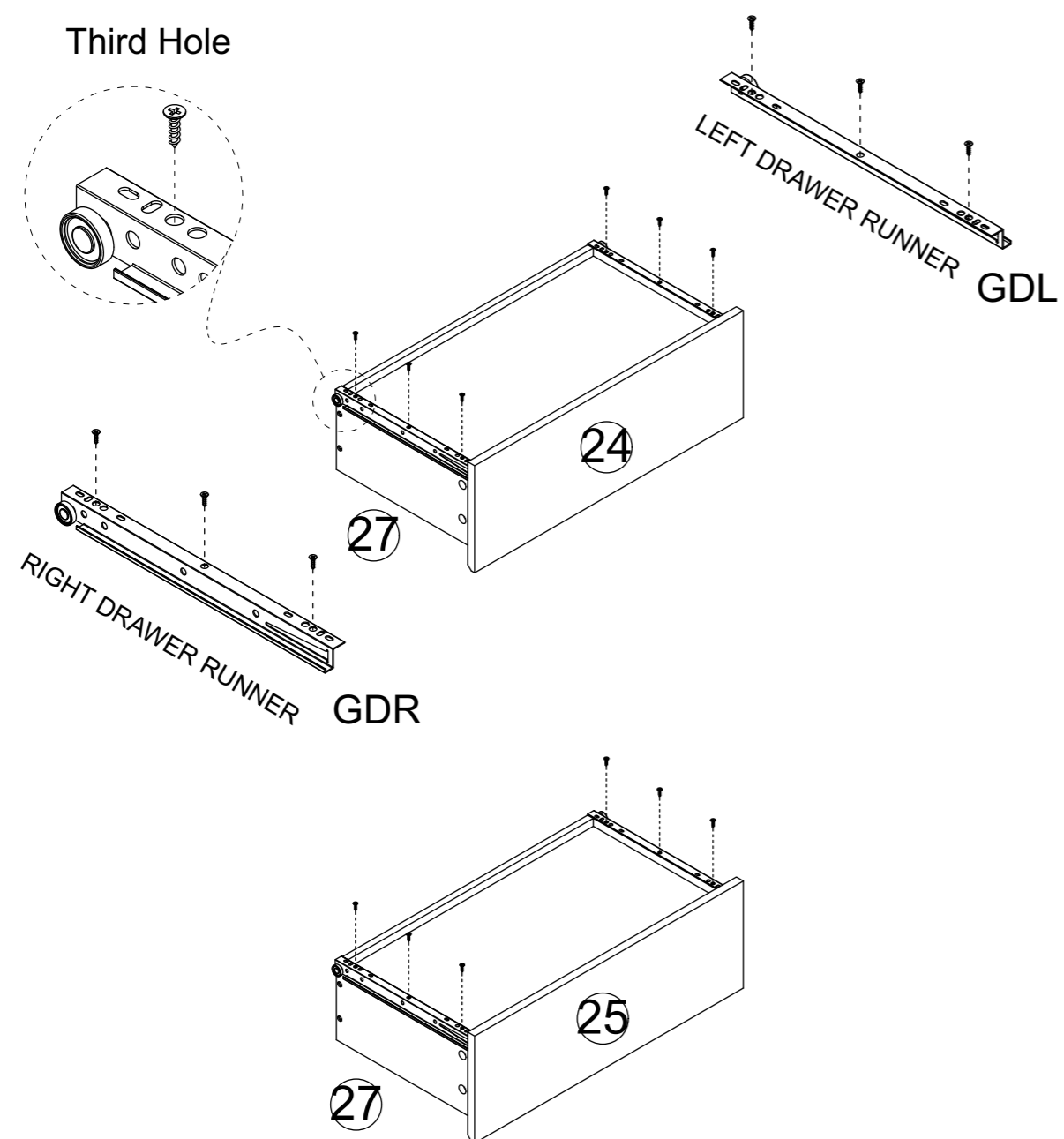

Use screw (E) to secure fitting (G) onto panels (26), (27), as shown.

Step 27

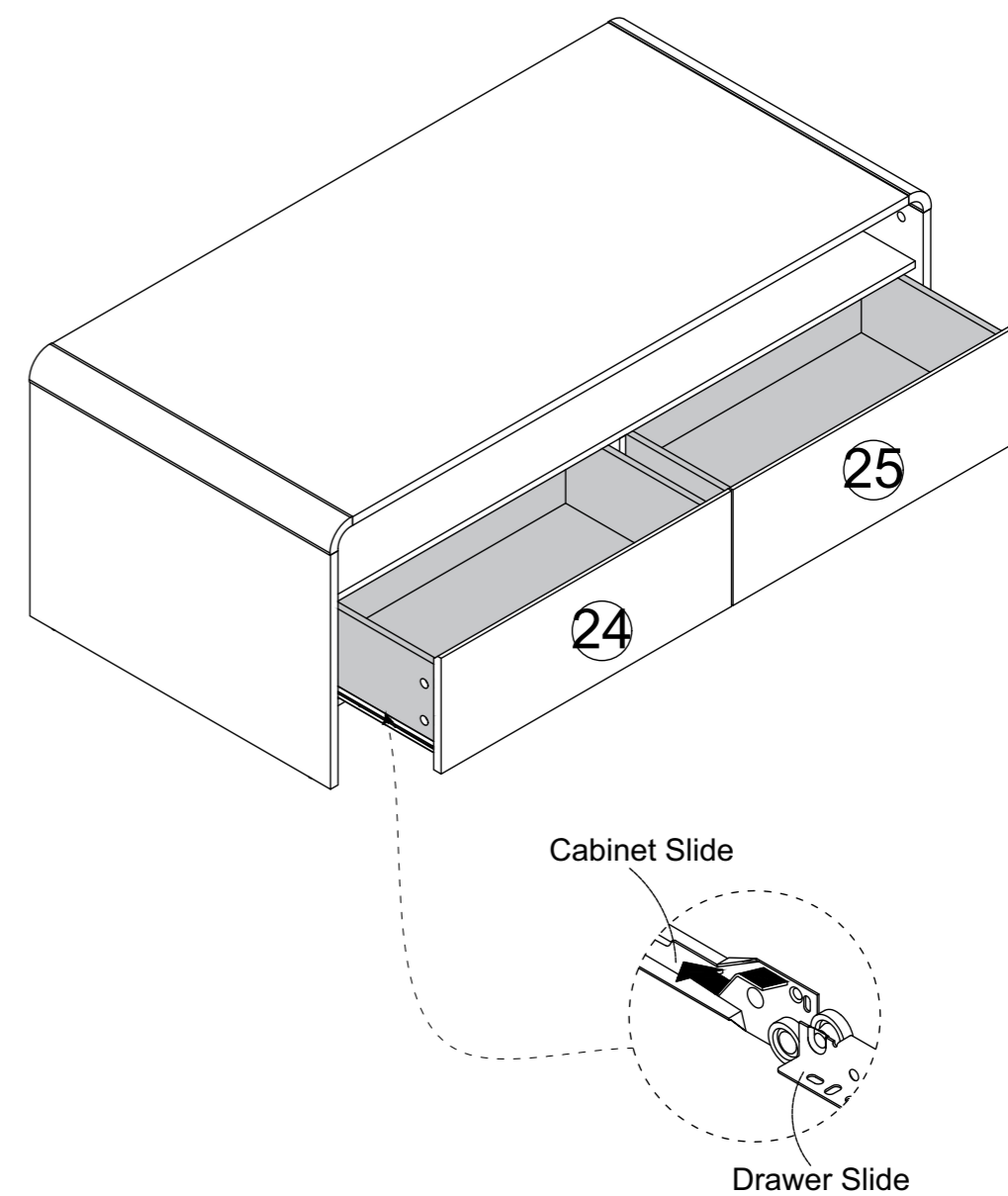
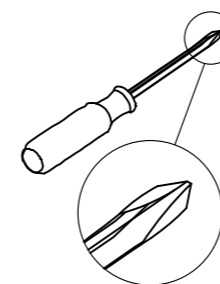

Push panels (24), (25) into the cabinet, aligning with the slots of fitting (G), as shown.