

Adirondack Counter/Bar Chair

Assembly Guide



*Actual Style May Vary from the One Pictured in this Guide

HARDWARE INCLUDED

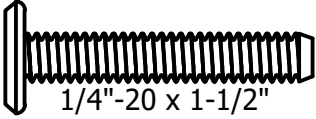
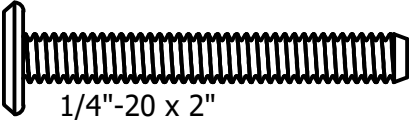
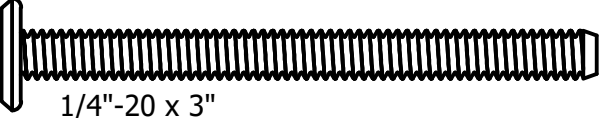
- A  Qty: 2
1/4"-20 x 1-1/2"
- B  Qty: 12
1/4"-20 x 2"
- C  Qty: 2
1/4"-20 x 3"

TOOLS INCLUDED

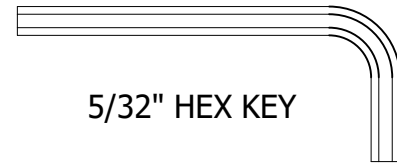

5/32" HEX KEY

IMPORTANT!

DO NOT fully tighten bolts until all bolts are started.

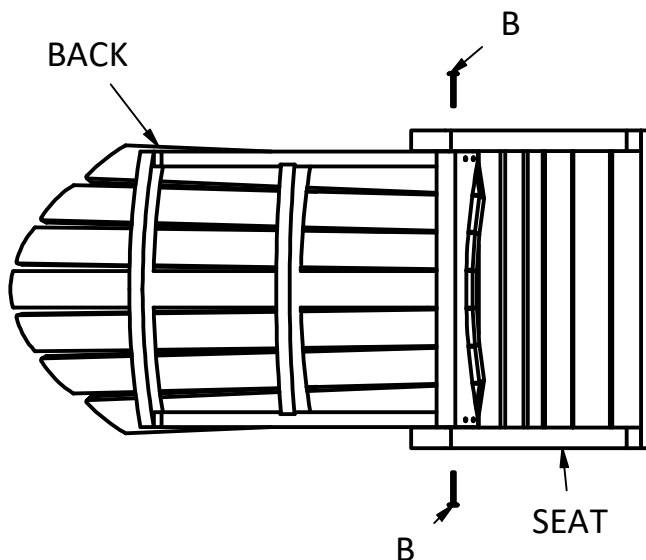

1) Insert (1) "B" Bolt into Lower Hole on Each Side to Attach Seat to Back. Make Sure the Back is Fully Upright. Make Bolts Snug, but Do Not Overtighten.

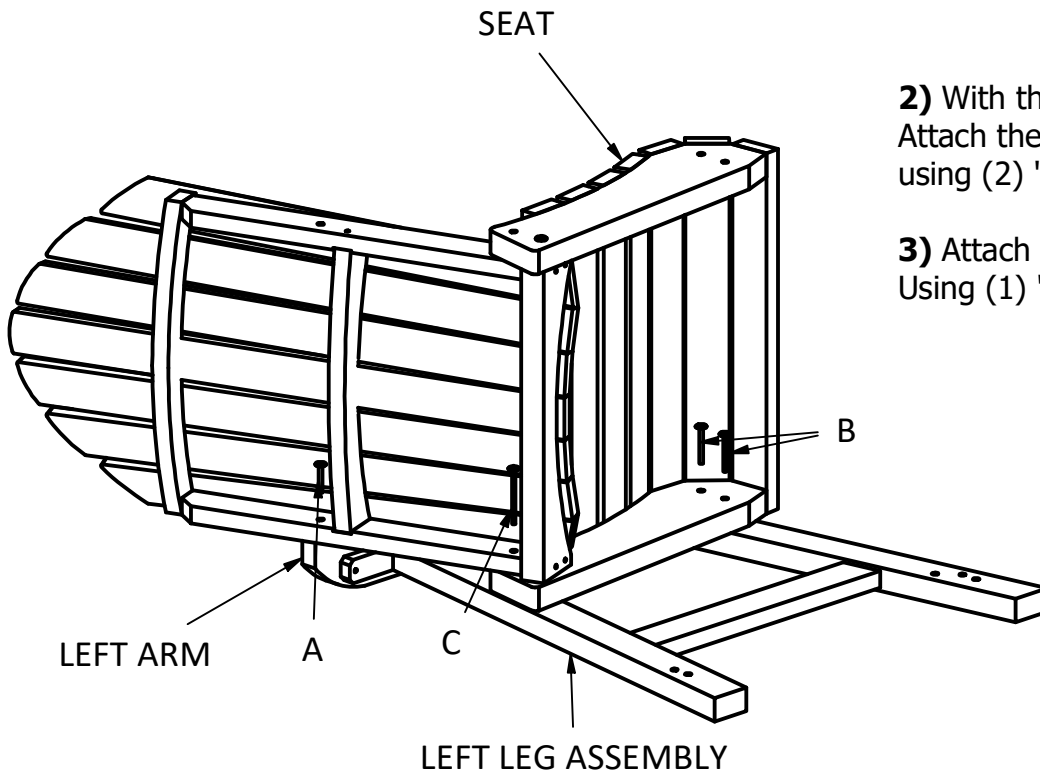

2) With the Chair Laying on its Left Side, Attach the Left Leg Assembly to the Seat using (2) "B" bolts and (1) "C" bolt.

3) Attach Left Arm to the Back Using (1) "A" Bolt.

FOOTREST ASSEMBLY

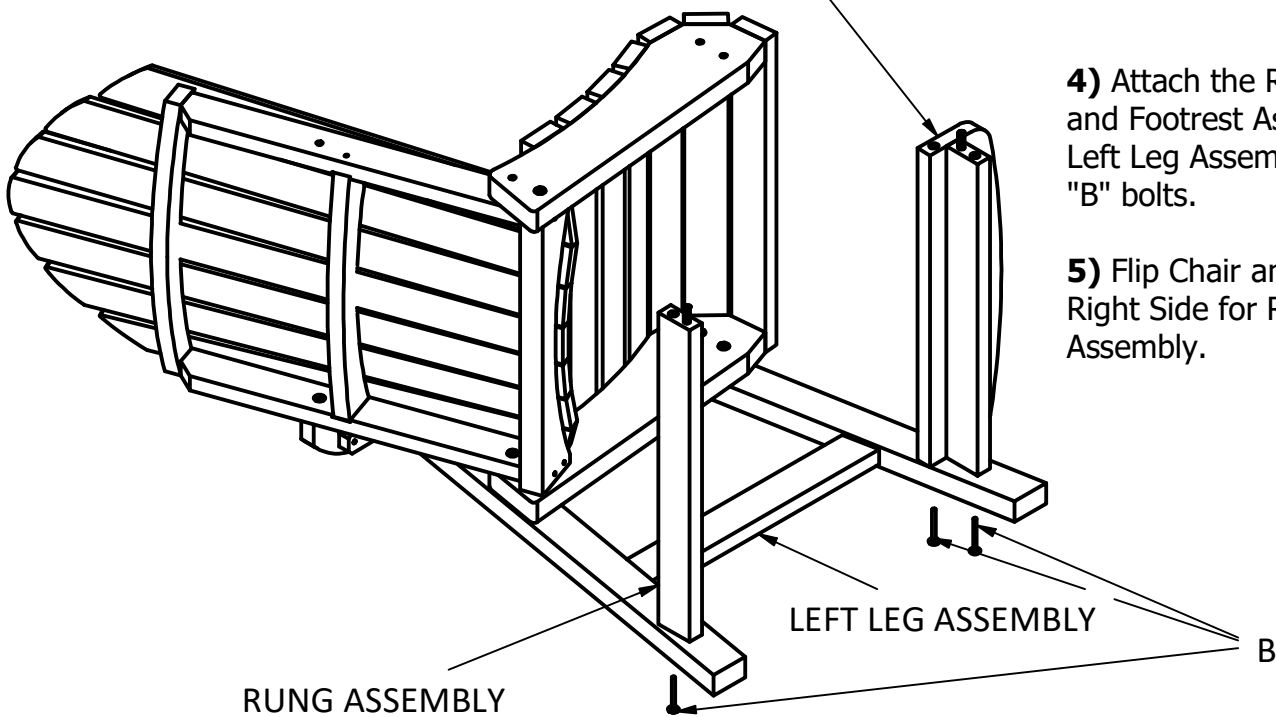

4) Attach the Rung Assembly and Footrest Assembly to the Left Leg Assembly using (3) "B" bolts.

5) Flip Chair and Repeat on Right Side for Right Leg Assembly.