

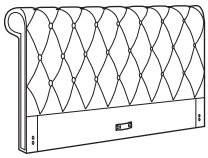

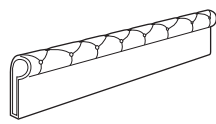

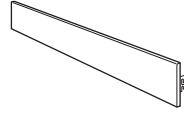

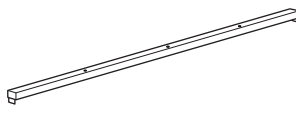

ASSEMBLY INSTRUCTION

PART LIST

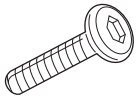
<p>1. HEADBOARD PANEL</p>  <p>x 1PC</p>	<p>2. FOOTBOARD PANEL</p>  <p>x 1PC</p>	<p>3. LEFT BED RAIL</p>  <p>x 1PC</p>	<p>4. RIGHT BED RAIL</p>  <p>x 1PC</p>
<p>5. ROLL SLAT</p>  <p>13pcs x 2 SET</p>	<p>6. CENTER RAIL</p>  <p>x 1PC</p>	<p>7. CENTER RAIL SUPPORT WITH LEVELER</p>  <p>x 3PCS</p>	<p>8. LEG</p>  <p>x 4PCS</p>

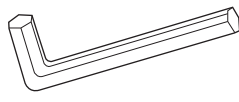
HARDWARE LIST *(IN ACTUAL SIZE/SCALE FOR REFERENCE)*

<p>A. JCBB SCREW M8 x 20mm</p>  <p>x 8PCS</p>	<p>B. CSK SCREW M4 x 16mm</p>  <p>x 6PCS</p>	<p>C. CSK SCREW M4 x 32mm</p>  <p>x 12PCS</p>
<p>D. L-KEY M5 x 65mm</p>  <p>x 1PC</p>	<p>E. PLASTIC WASHER</p>  <p>x 4PCS</p>	<p>F. ADJUSTABLE (BIG)</p>  <p>x 3PCS</p>

STEP 1

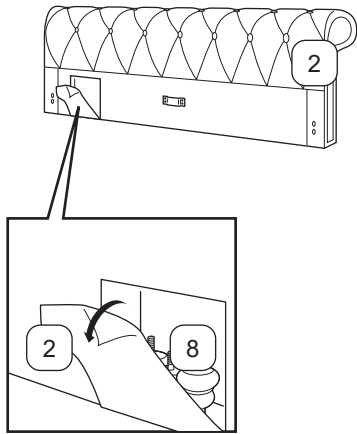

Bed leg (8) put in front side footboard (2).

STEP 2

E x 4

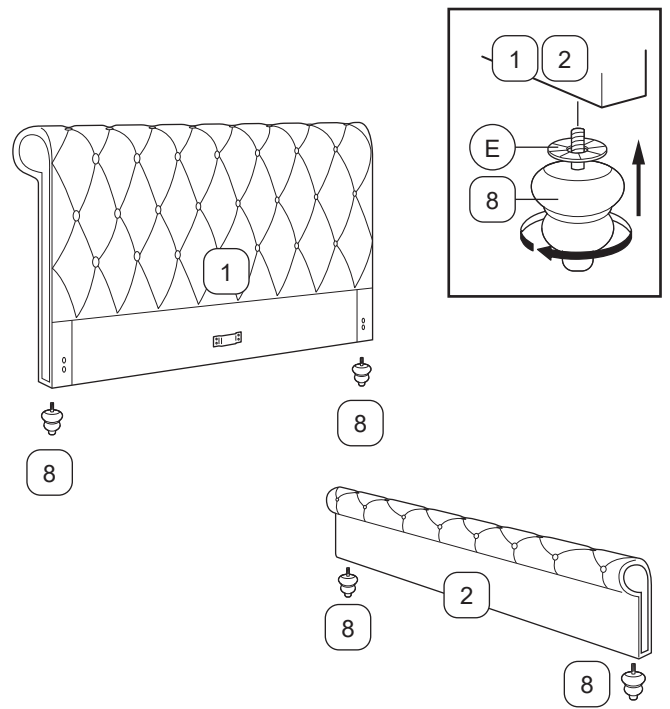

Secure 2 pieces of Legs (8) with Plastic Washer (E) to the bottom of Headboard (1). Tighten the Legs (8) lockwise until secure. Then secure another 2 pieces of Legs (8) with Plastic Washer (E) to the Footboard (2) by using same method.

STEP 3

A x 4 D x 1

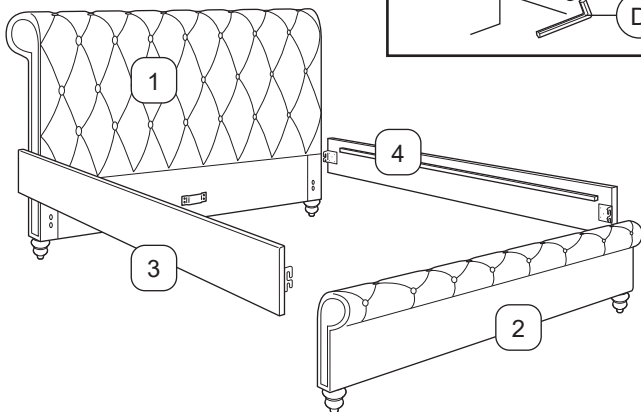
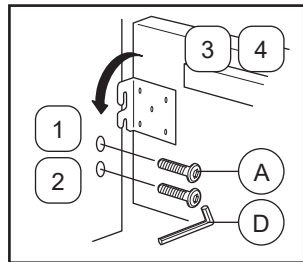

Attach Side Rail (3) and (4) to Headboard (1) and Footboard (2) by securing with 2 Allen Bolts (A) using L-key (D). Insert the bolts into Headboard (1) and Footboard (2) but do not tighten it in all the way. After, hook on the rail onto the bolt and tighten the bolt when the rails are hooked on properly.

STEP 4

B x 6 F x 3

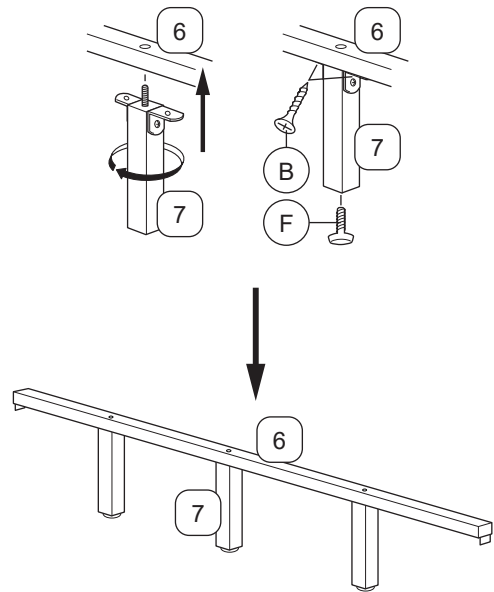

Attach 3 Center Rail Support with leveler (7) to Center Rail (6) using Screw (B) and Adjustable (Big) (F).

STEP 5

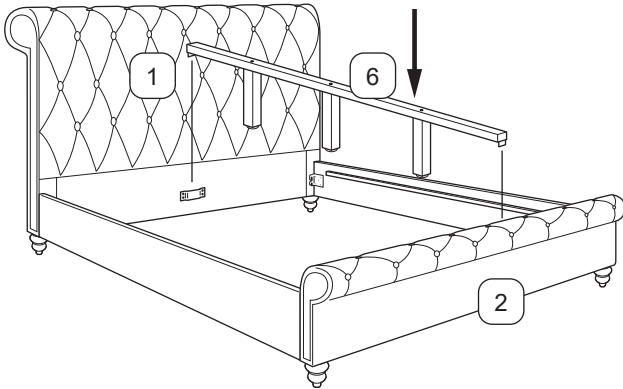
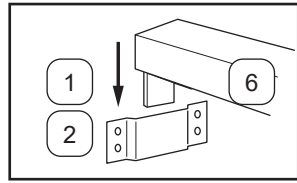

Insert Center Rail (6) to the bracket (provided) on Headboard (1) & Footboard (2).

STEP 6

C x 12

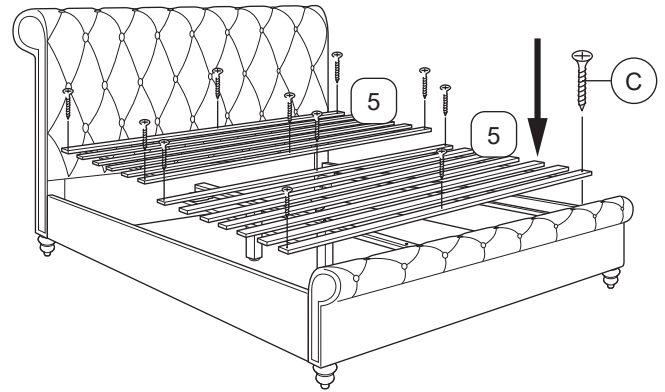
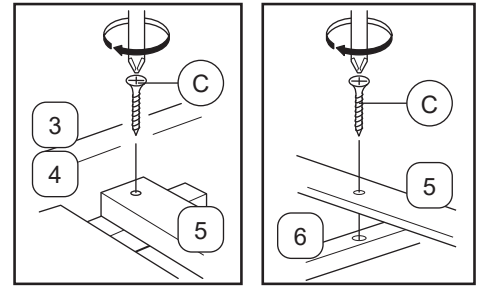

Attach Roll Slat (5) to Side Rail (3) & (4) using 8 Screw (C). Tighten the Screw (C) with Philips Head Screw Driver (not provided). Then Roll Slat (5) to Center Rail (6) using 4 Screw (C) by using same method.

STEP 7

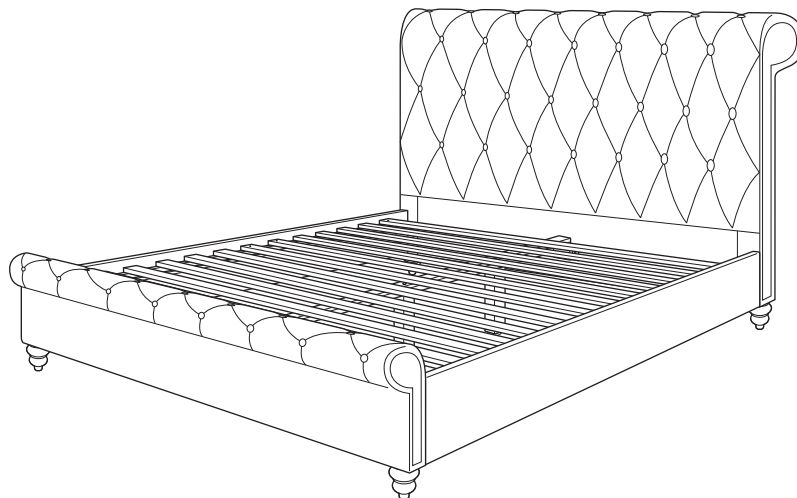

Your bed is now ready!
Make sure all screw are fully tightened before using.
Do not jump or stand on top.

ASSEMBLY
COMPLETED