

Assembly Instructions

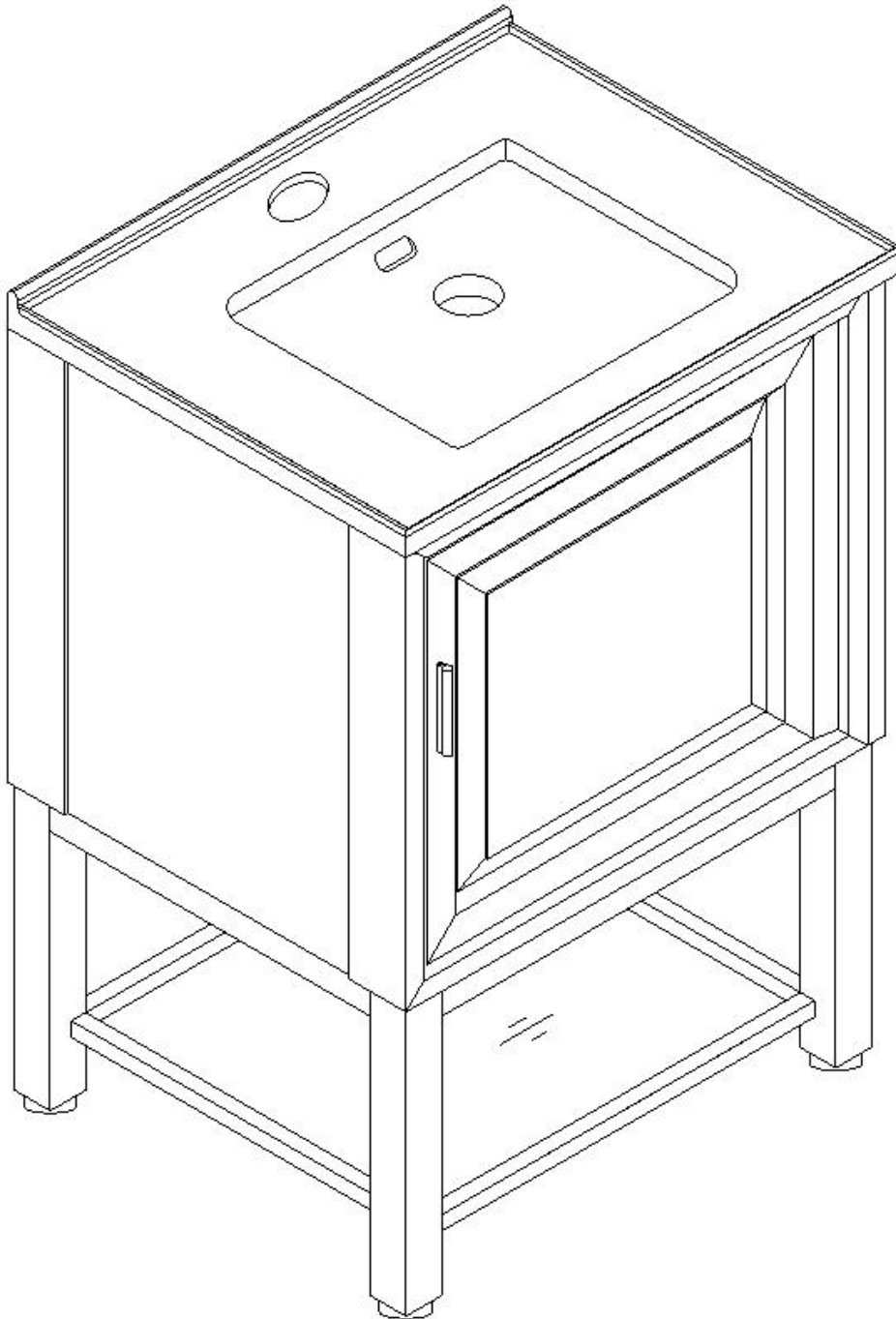

www.festival-usa.com

US Customer Service Hotline: +1 909-344-7217

US Customer Service E-mail: customerservice@festival-usa.com

SAFETY INFORMATION

INFORMATION DE SÉCURITÉ

INFORMACIÓN DE SEGURIDAD



Please read and understand this entire manual before attempting to assemble, operate or install the product.



WARNING

- Some steps are more easily handled with two adults.

CAUTION

- Before assembly and/or installation, carefully unwrap all parts.
- Locate and set aside the hardware kit before discarding packaging.
- Use care when assembling your new product. Take your time and follow the assembly instructions closely.



Assurez-vous de lire et de comprendre l' intégralité du présent manuel avant de tenter d' assembler, d' utiliser ou d' installer le produit.



AVERTISSEMENT

- Certaines étapes sont plus faciles à effectuer avec l' aide

MISE EN GARDE

- Avant l' assemblage et/ou l' installation, vous devez déballer minutieusement toutes les pièces.
- Localisez et mettez de côté le jeu de quincaillerie avant de jeter l' emballage.
- Soyez vigilant lorsque vous assemblez le nouveau produit. Prenez votre temps et suivez attentivement ces instructions.



Lea y comprenda completamente este manual antes de intentar ensamblar, usar o instalar el producto.



ADVERTENCIA

- Algunos de los pasos se pueden realizar con mayor facilidad entre dos adultos.

PRECAUCIÓN

- Antes del ensamblaje y/o instalación, desenvuelva cuidadosamente todas las piezas
- Localice y separe el equipo de accesorios antes de desechar el embalaje.
- Tenga cuidado al ensamblar el nuevo producto. Tómese su tiempo y siga detenidamente las instrucciones de ensamblaje.

TOOLS REQUIRED OUTILS NÉCESSAIRES HERRAMIENTAS NECESARIAS

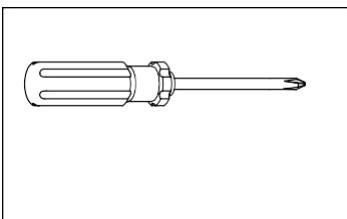

(NOT INCLUDED) (PAS INCLUS) (NO INCLUIDAS)

Parts List

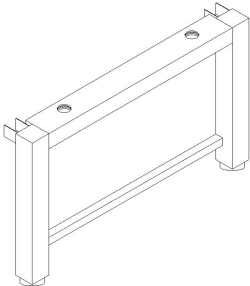
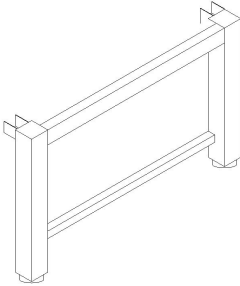
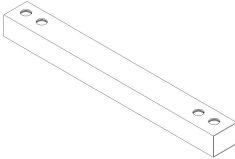
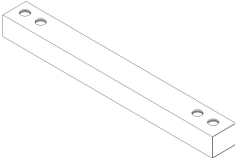
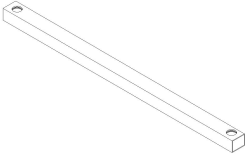
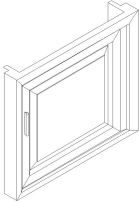
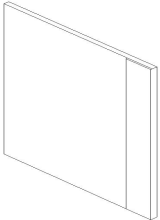
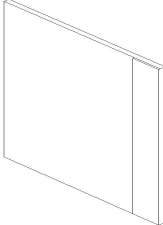
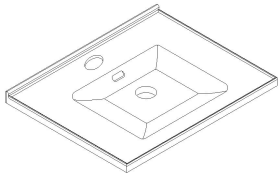
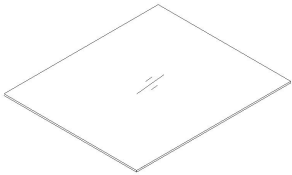
		
<p align="center">A Base Front Frame X 1</p>	<p align="center">B Base Back Frame X 1</p>	<p align="center">C Base Left Top Rail X 1</p>
		
<p align="center">D Base Right Top Rail X 1</p>	<p align="center">E Base Side Bottom Rail X 2</p>	<p align="center">F Top Front Frame X 1</p>
		
<p align="center">G Top Right Side Panel X 1</p>	<p align="center">H Top Left Side Panel X 1</p>	<p align="center">I Top Basin X 1</p>
		
<p align="center">J Shelf Glass X 2</p>		

Hardware List

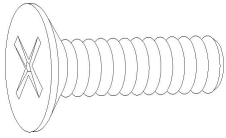

①
Shorter Screw
X 20

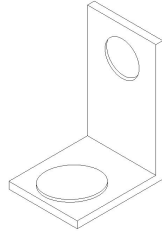

②
L Bracket
X 4

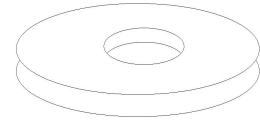

③
Smaller Flat Washier
X 12

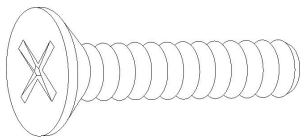

④
Longer Screw
X 4

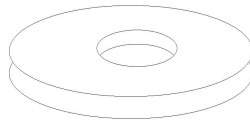

⑤
Bigger Flat Washier
X 4

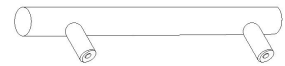

⑥
Handle
X 1

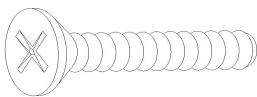

⑦
Handle Screw
X 2

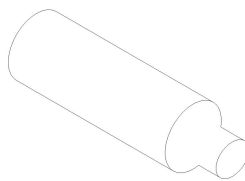

⑧
Basin Glue
X 1

Step 1

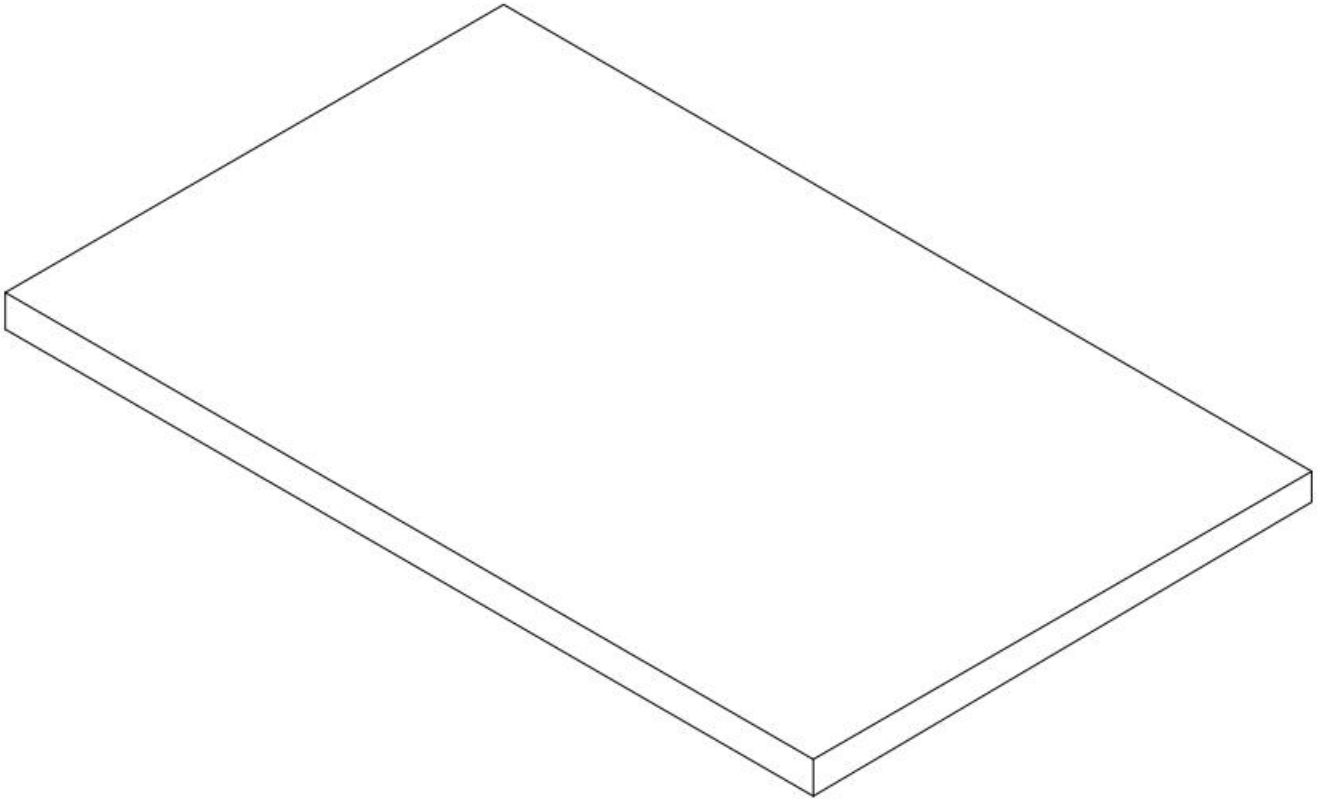

1. It is recommended that we prepare a piece clean cloth or foam sheet to prevent unnecessary scratches on the surface of the product for the assembly.

Step 2

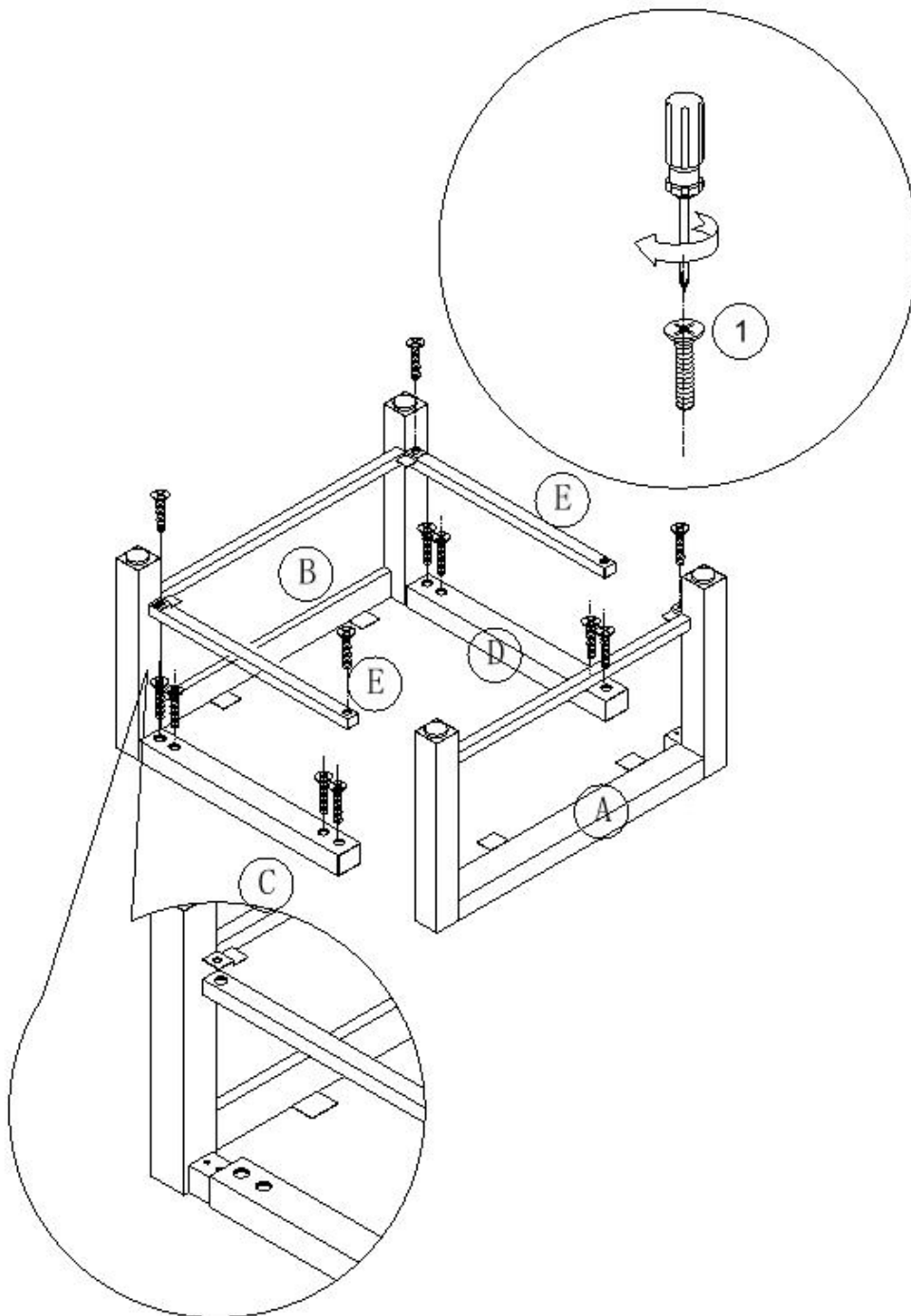

1. Attached the 1pc Base Front Frame A, the 1pc Base Back Frame B, the 1pc Base Left Top Rail C, the 1pc Base Right Top rail D and 2pcs Base Side Bottom Rail E together using 12pcs Shorter Screw ①. Aline all parts then tight all the screws.

Step 3

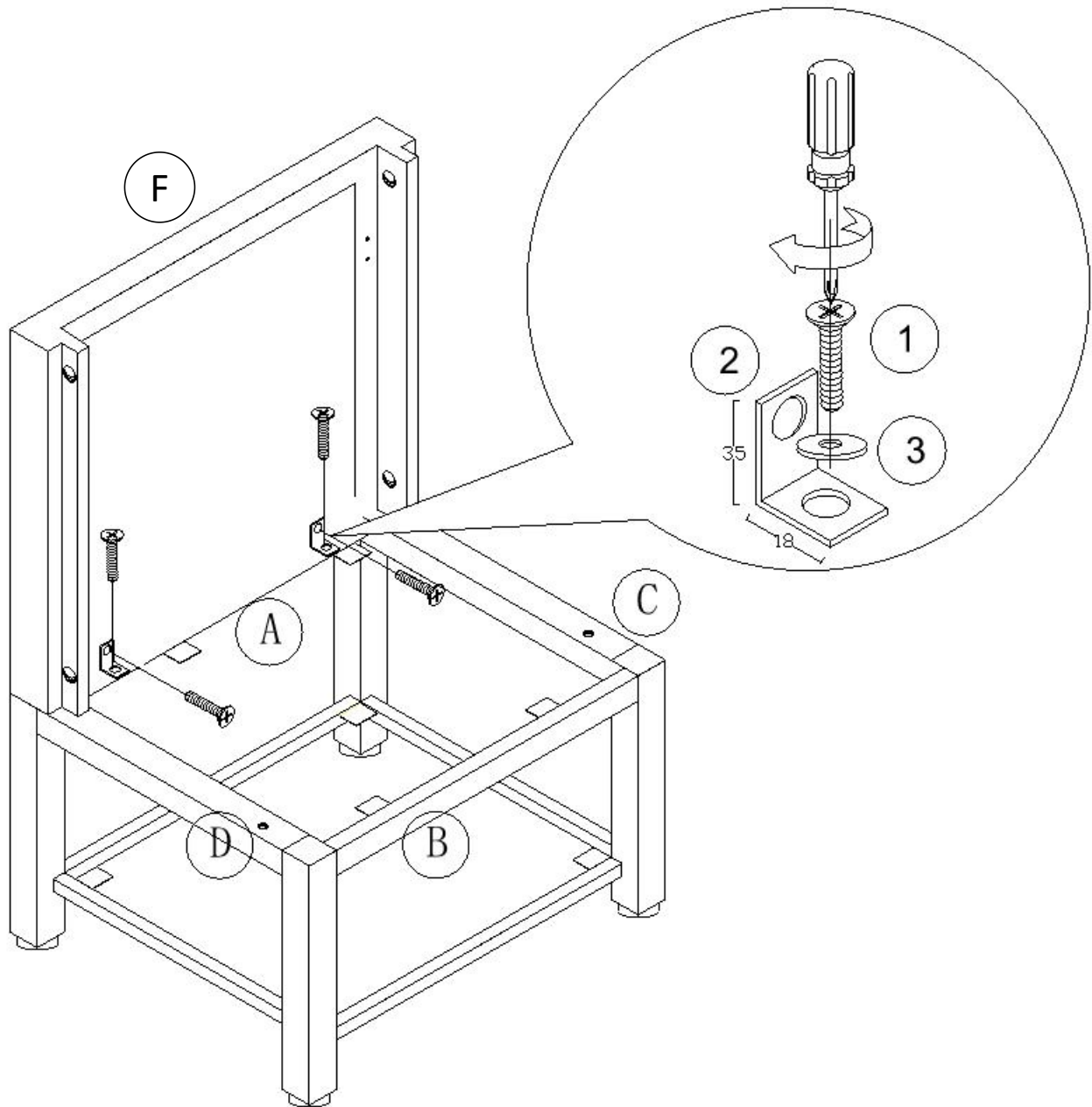

1. Turn up the assembled metal base, and attach the Top Front Frame F to the assembled parts using 4pcs Shorter Screw ①, 4pcs Smaller Flat Washier ③ and 2pcs L Bracket ② by screw driver as shown. **Make sure the long side of L Braket to be on Top Front Frame !!**

Step 4

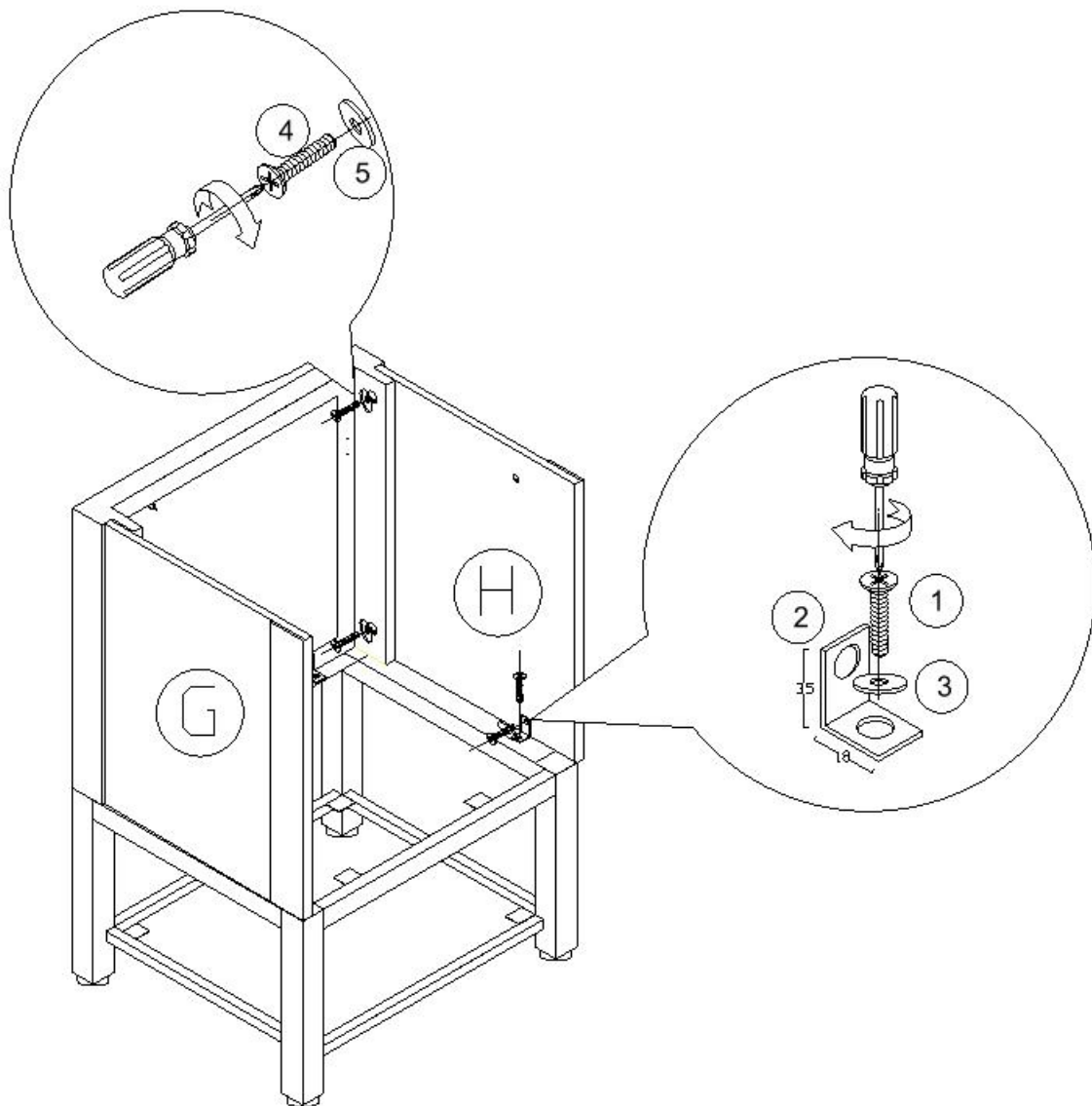

1. Attach the Top Left Side Panel H to the assembled base using 2pcs Shorter Screw ①, 2pcs Smaller Flat Washer ③ and 1pc L Bracket ② , then 2pcs Longer Screw ④ and 2pcs Bigger Flat Washer ⑤ by screw driver as shown. **Make sure the long side of L Braket to be on both side panels !!**

Step 5

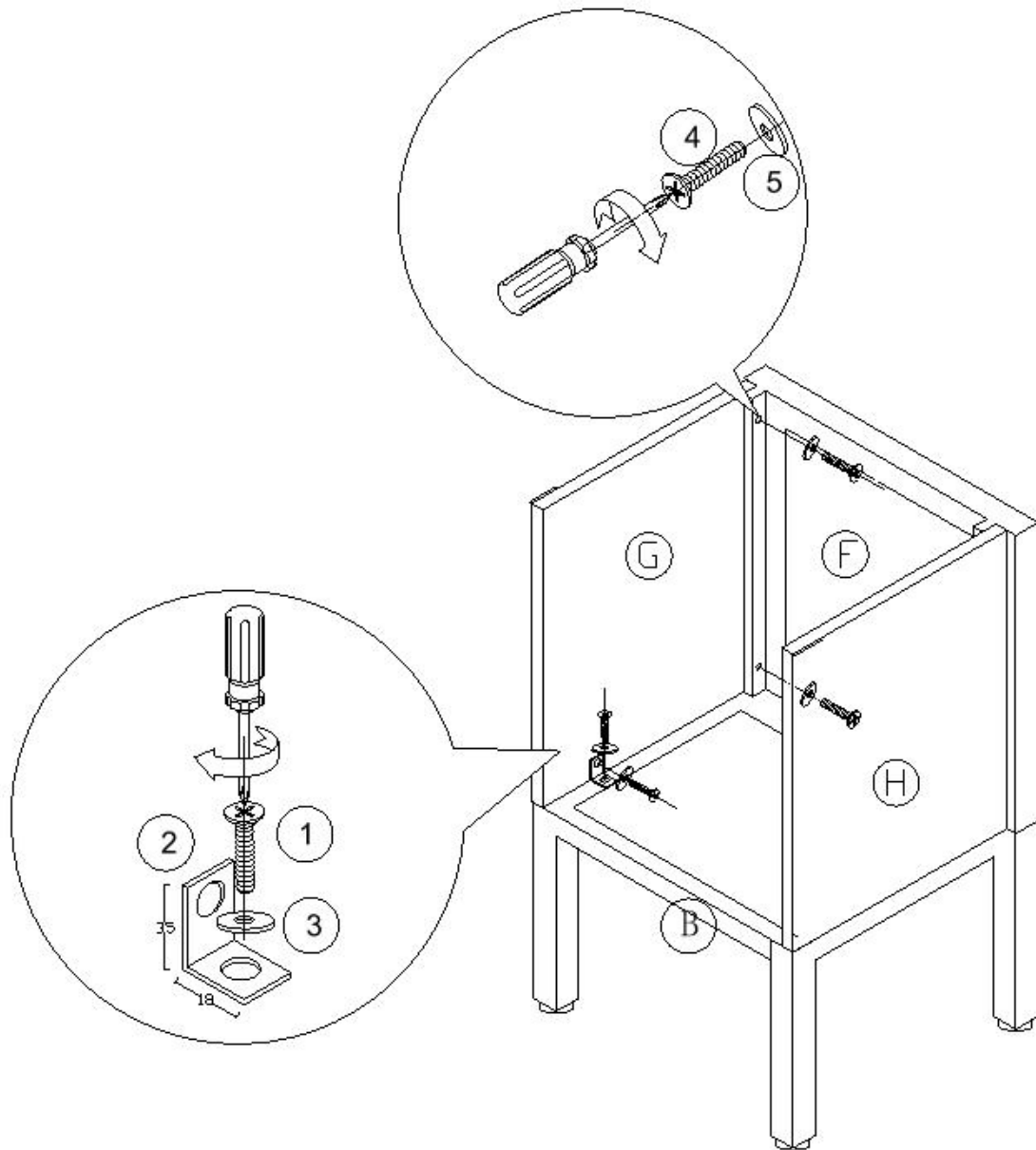

1. Attach the Right Top Side Panel G to the assembled base using 2pcs Shorter Screw ①, 2pcs Smaller Flat Washier ③ and 1pc L Bracket ② , then 2pcs Longer Screw ④ and 2pcs Bigger Flat Washier ⑤ by screw driver as shown. **Make sure the long side of L Braket to be on both side panels !!**

Step 6

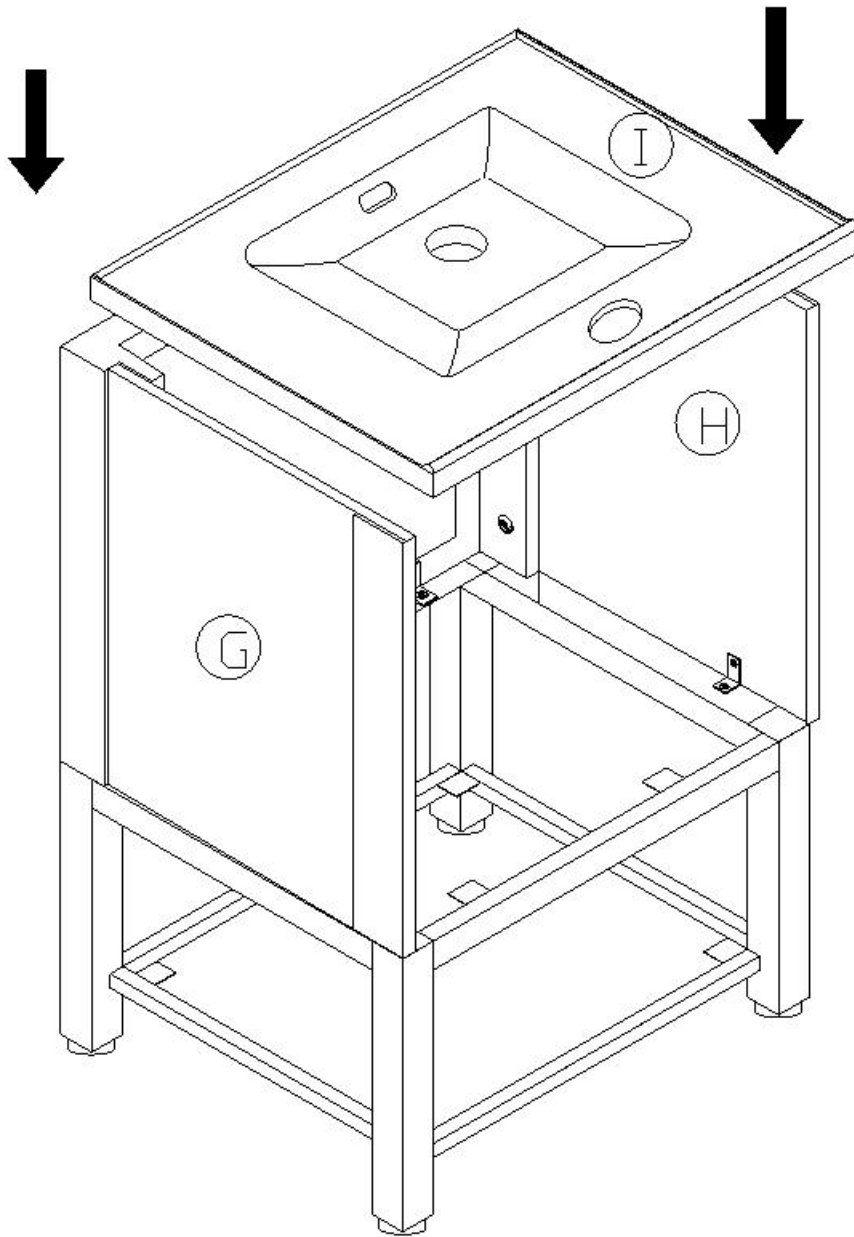

1. Put on the Basin I to the assembled parts. **Make sure the Basin I to be alined with both right&left sides and the back end to be flush with the back of the assembled parts.**

Step 7

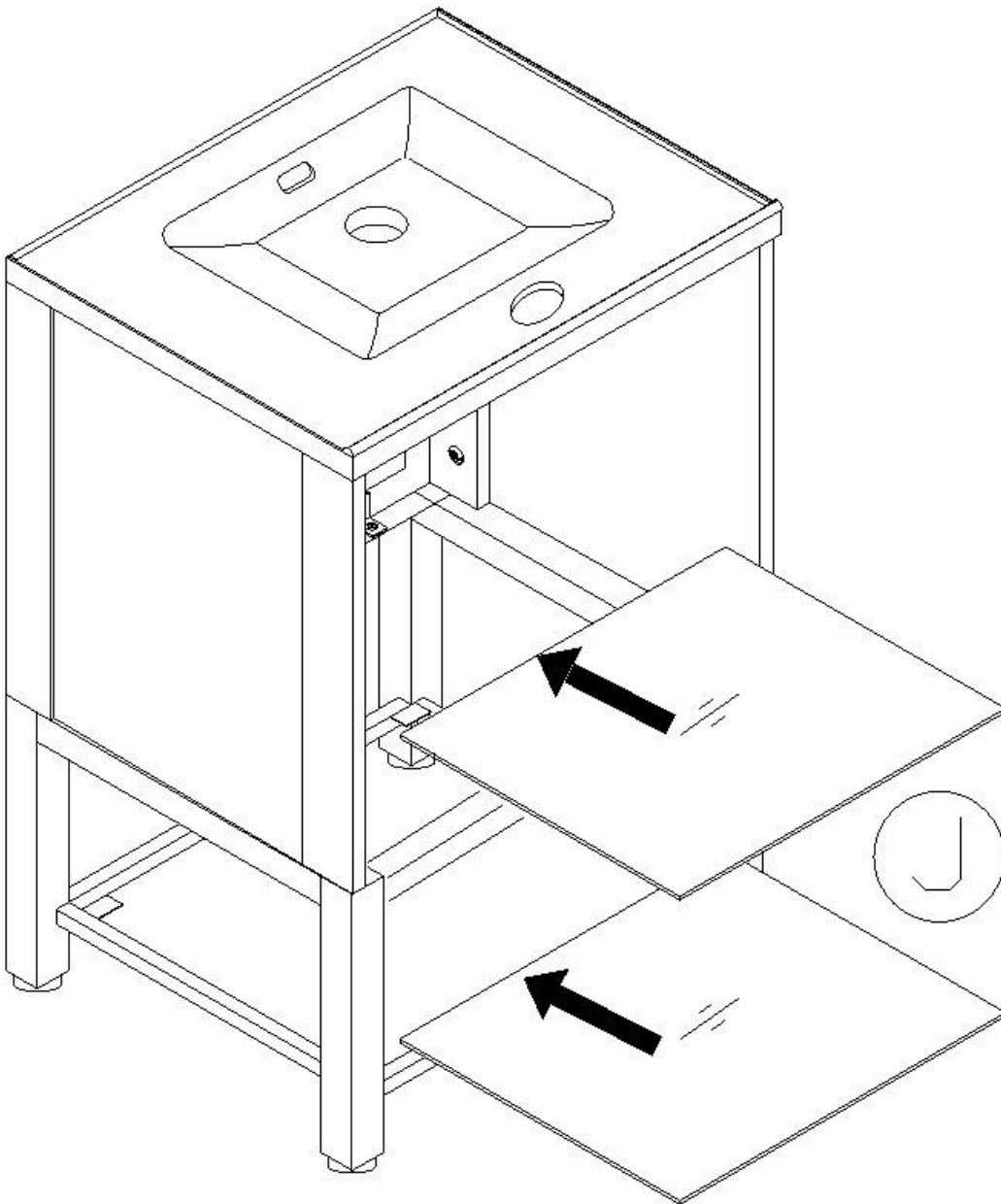

1. Place 2pcs Shelf Glass J as shown.

Step 8

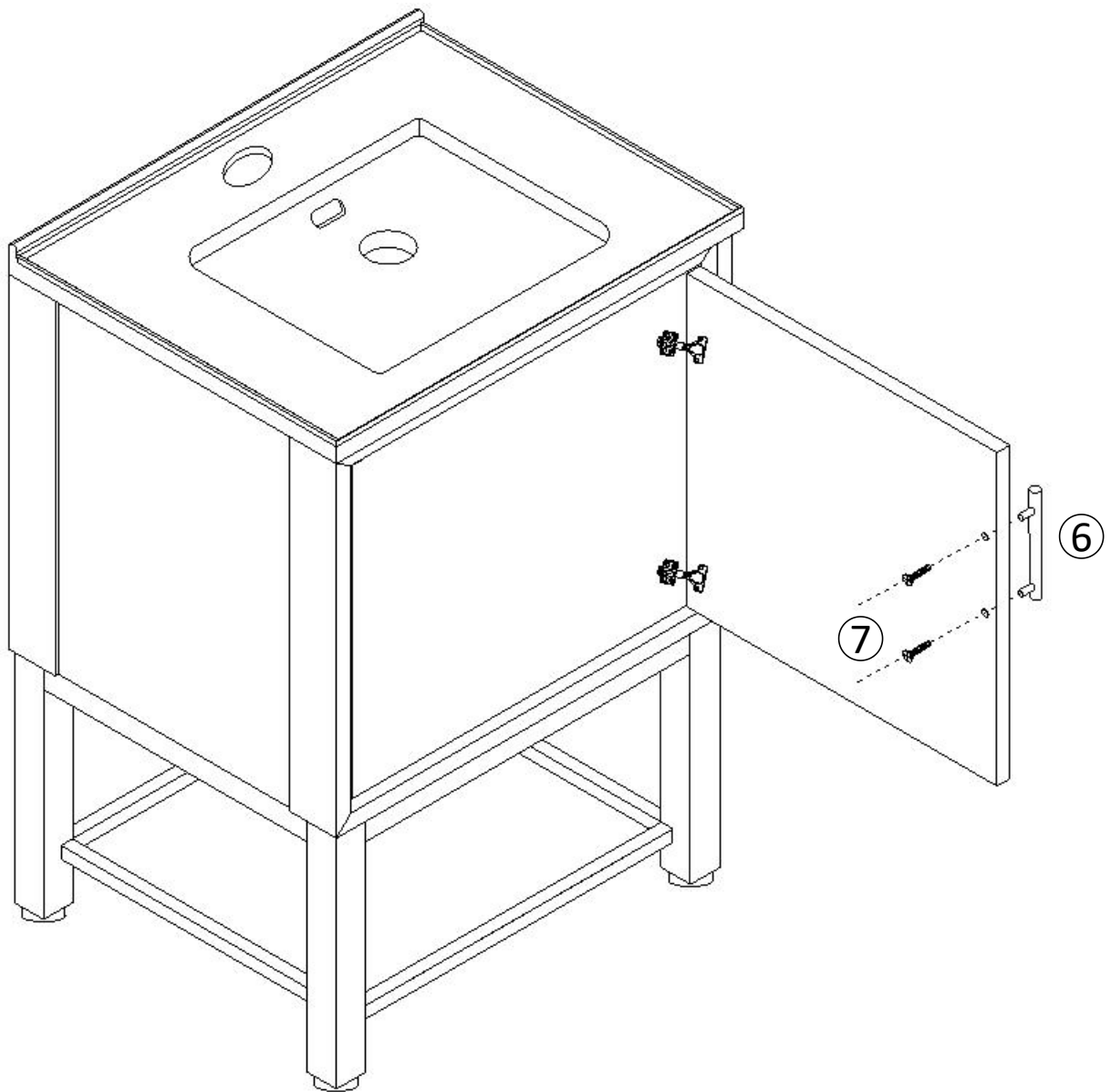

1. Attach 1pc Handle ⑥ to the door using 2pcs Handle Screw ⑦ as shown.

Step 9

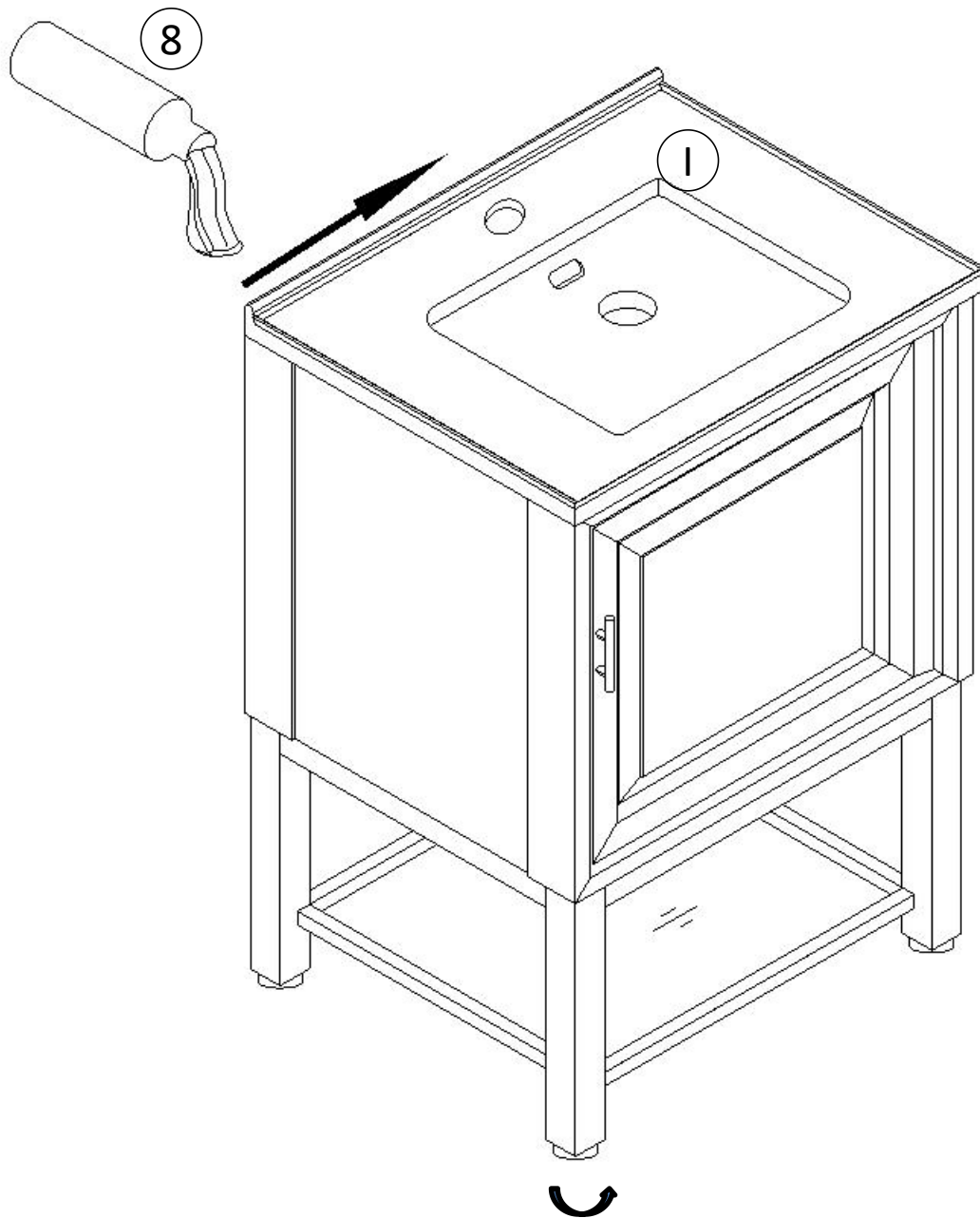

1. Adjust the leveler on the leg to make sure all legs are against the floor.
2. After assembled the faucet, move the product to the desided place, and glue the Top Basin I to the wall using Basin Glue (8) . **Make sure the Top Basin I to be alined.**

CARE / MAINTENANCE

Care and Maintenance

- Use a soft, clean cloth that will not scratch the surface when dusting.
- Using solvents of any kind on your furniture may damage the finish.
- Never use water to clean your furniture as it may cause damage to the finish.
- Always use coasters under beverage glasses and flowerpots.
- Liquid spills should be removed immediately, as it may damage the furniture. Use a soft, clean cloth and blot the spill gently. Avoid rubbing.
- Always use protective pads under hot dishes and plates. Heat can cause chemical changes that may create spotting within the furniture.

Further advice about wood furniture care

It is best to keep your furniture in a climate-controlled environment. Temperature and humidity changes can cause fading, warping, shrinking and splitting of wood. It is advised to keep furniture away from direct sunlight as sun may damage the finish. Proper care and cleaning at home will extend the life of your purchase.

We hope you enjoy your purchase for many years. Thank you for your purchase!

SOIN / ENTRETIEN

Soin / Entretien

- Lors de l' époussetage, utilisez un chiffon doux et propre qui n' égratigne pas la surface.
- L' utilisation de solvant de quelque sorte sur votre ameublement peut endommager le fini.
- Ne jamais utiliser d' eau pour nettoyer votre ameublement car cela peut endommager le fini.
- Utilisez toujours des dessous de verre sous les verres/tasses des breuvages et sous les pots à fleur.
- Tout déversement de liquide doit être enlevé immédiatement car cela peut endommager l' ameublement. Utilisez un chiffon doux et propre et éponger délicatement le déversement. Évitez de frotter.
- Utilisez toujours des tampons protecteurs sous les plats et les assiettes chaudes. La chaleur peut causer des changements chimiques qui peuvent créer des taches sur l' ameublement.

Conseils supplémentaires pour l' entretien de meubles en bois

Il est préférable de garder vos meubles dans un environnement climatisé. Les changements de température et d' humidité peuvent décolorer, déformer, rétracter et fendiller le bois. Il est conseillé de garder les meubles à l' abri de la lumière directe du soleil car cela pourrait endommager le fini. L' entretien et le nettoyage appropriés à domicile prolongeront la vie de votre achat.

Nous espérons que vous apprécierez votre achat pendant de nombreuses années. Nous vous remercions pour votre achat!

CUIDADO / MANTENIMIENTO

Cuidado / Mantenimiento

- Use un paño suave y limpio que no raye la superficie cuando elimine el polvo.
- Usar solventes de cualquier clase en sus muebles puede dañar el acabado.
- Nunca utilice agua para limpiar sus muebles, ya que puede causar daños en el acabado.
- Siempre utilice posavasos para colocar los vasos de bebidas y las macetas.
- Los derrames de líquidos se deben recoger inmediatamente, ya que pueden dañar el mueble. Use un paño suave y limpio y seque el derrame con cuidado. Evite frotar.
- Siempre utilice almohadillas protectoras debajo de los platos y vajillas calientes. El calor puede causar cambios químicos los cuales pueden crear manchas en los muebles.

Consejos adicionales sobre el cuidado de los muebles de madera

Lo mejor es mantener sus muebles en un ambiente con clima controlado. Los cambios de temperatura y humedad pueden hacer que la madera se decolore, se combe, se encoja y se parta. Se aconseja mantener los muebles alejados de la luz solar directa, ya que esta puede dañar el acabado. El cuidado y la limpieza adecuados en casa extenderán la vida útil de su compra.

Esperamos que disfrute de su compra durante muchos años. ¡Gracias por su compra!