

Installation Instruction

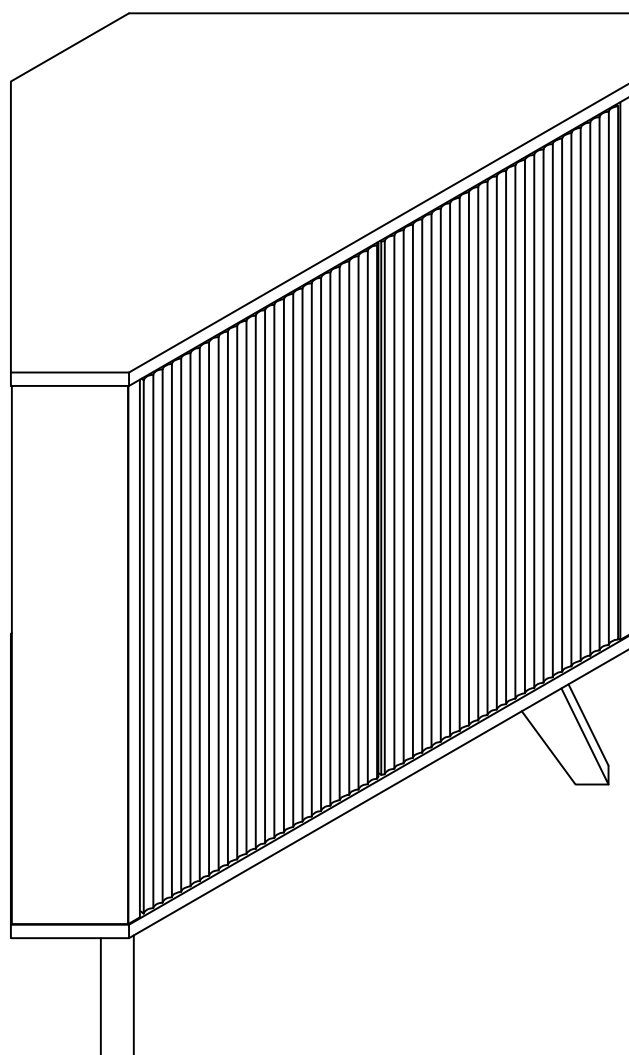

Assembling

Estimated time for assembly



45 : 00

What you need

- Use the packaging carton as a working surface to prevent product damage during assembly
- Phillips head screwdriver

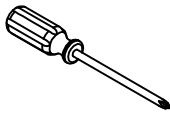

Weight Limitation



100 | **35**
lbs table top lbs per

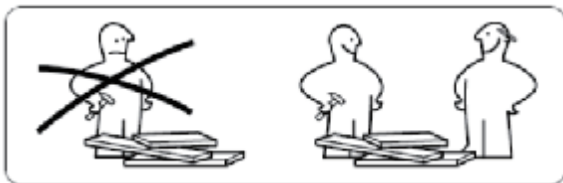

What' included

Code	Description	Qty
A	Cam Bolt M6X35MM	10
B	Cam Lock 15X12MM	10
C	Wooden Dowel M8X30MM	9
D	Screw M4X40MM	10
E	Screw M3.5X14MM	4
F	Shelf Holder	3
G	Nylon Strap	2
H	Screw M3.0X14MM	36
I	Foot nail	3
J	The back button	16
K	Anchor	4
L	Hinge	4
M	Screw M7X50MM	3
N	Door Rebound Device	2
O	Door Rebound Device Holder	2
P	Screw M4X25MM	4
Q	Wrench M4X55MM	1
R	Anti-tip iron sheet	2

The Hardwares

(A)

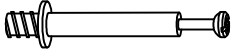

(B)

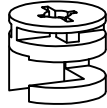

(C)

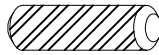

(D)

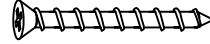

(E)



(F)



(G)

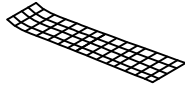

(H)



(I)



(J)

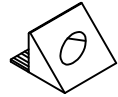

(K)



(L)



(M)

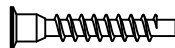

(N)

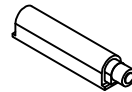

(O)

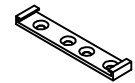

(P)



(Q)



(R)



IMPORTANT:

1. Do not tighten bolts / screws completely until all bolts / screws are lined up and inserted into holes.
2. Do not over tighten screws and bolts to avoid stripping
3. Please use hand tools to assemble this product. Do not use power tools.

Included Accessories

Code	Description	Qty
1	Cabinet Top	1
2	Bottom Panel	1
3	Medial plate	1
4	Movable laminated plate	1
5	Left front baffle	1
6	Right front baffle	1
7	Movable laminated plate	1
8	Back riser	1
9	Metal Door	2
10	Backboard	2
11	Supporting foot	3

The Accessoriess

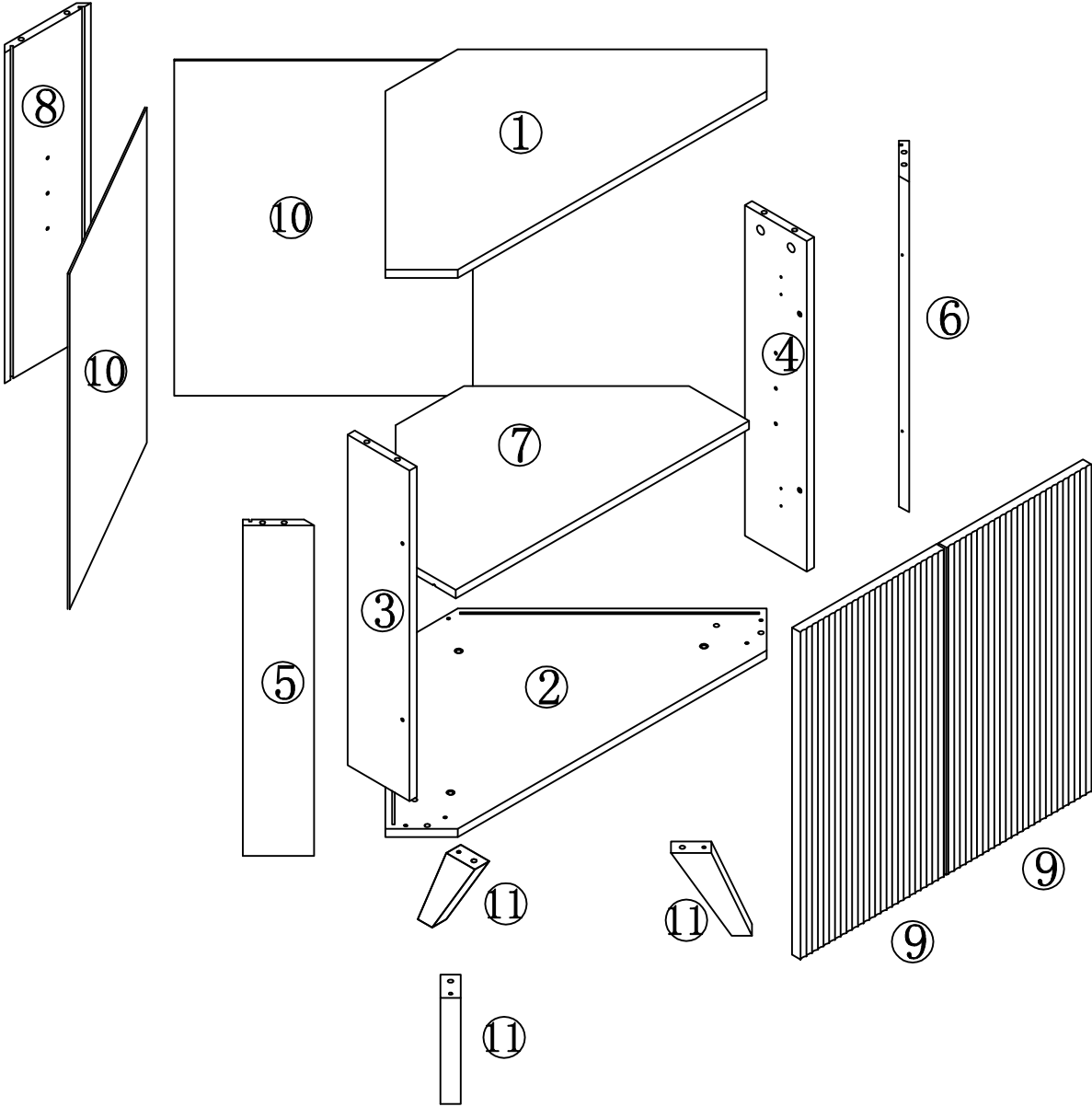

Step 1

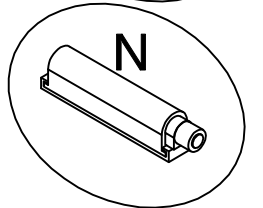
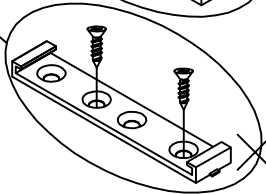
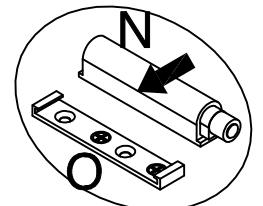
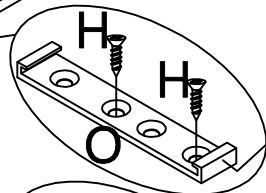
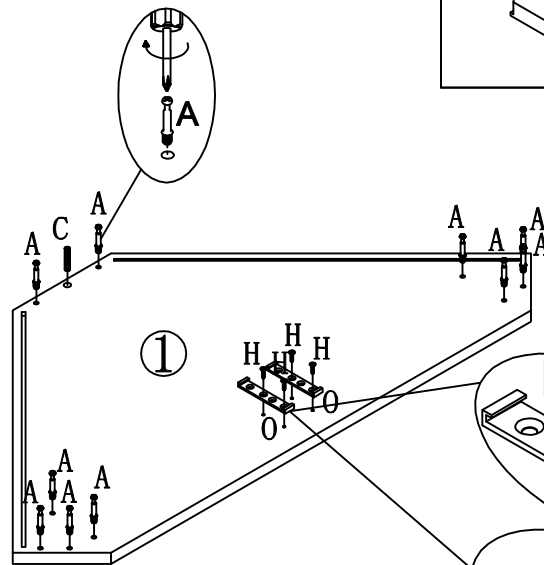
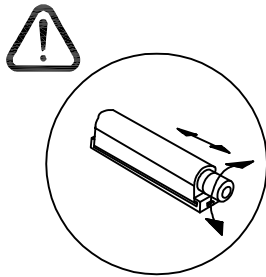
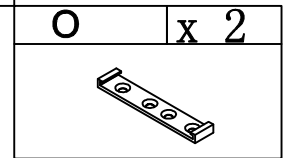
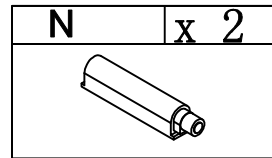
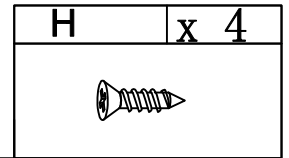
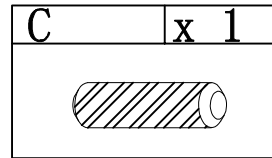
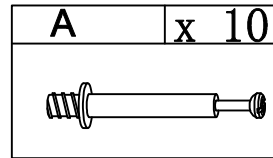

Step 2

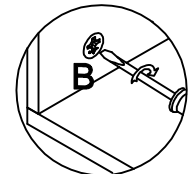
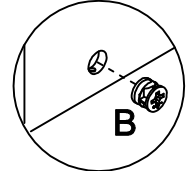
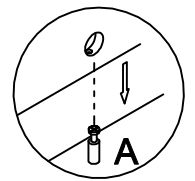
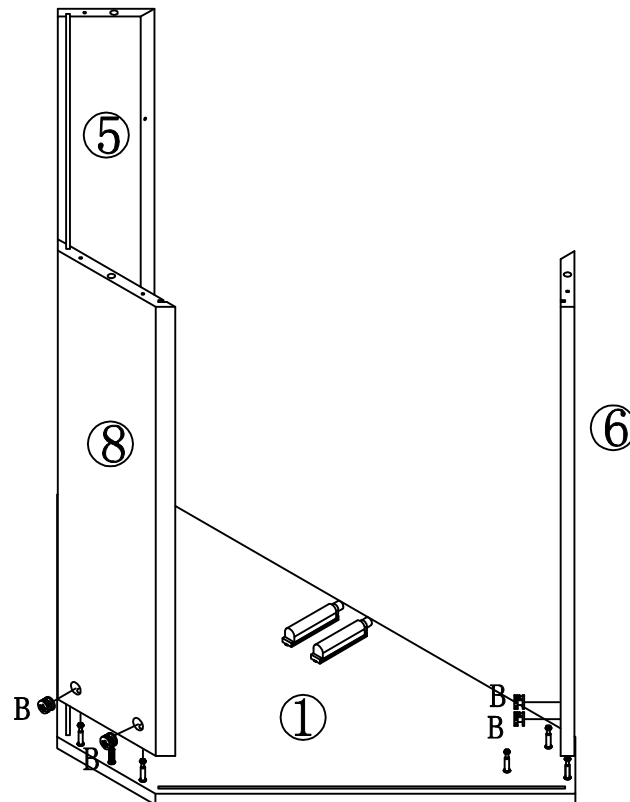
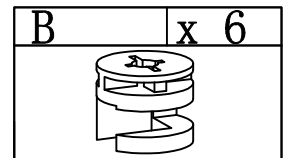

Step 3

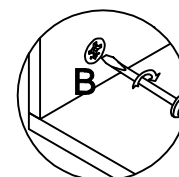
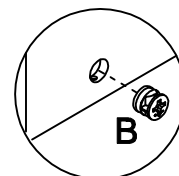
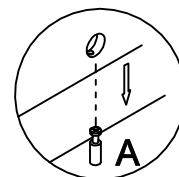
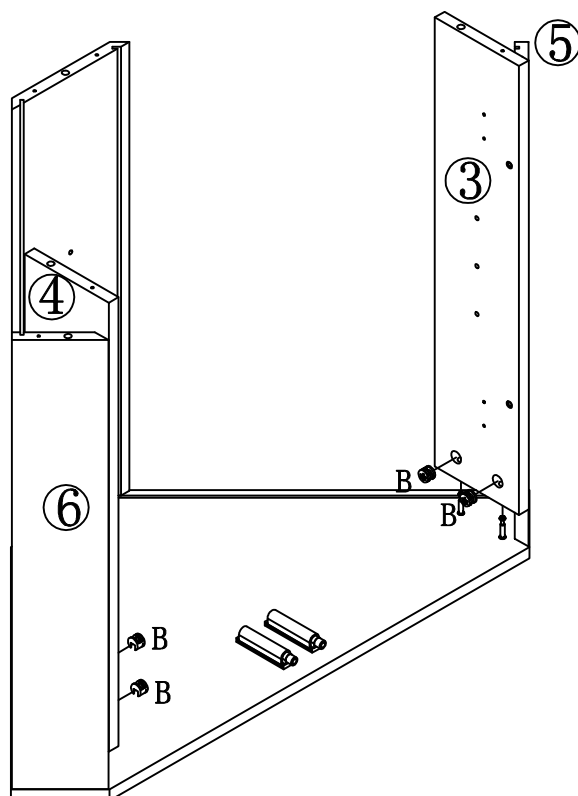
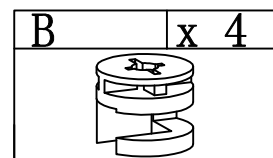

Step 4

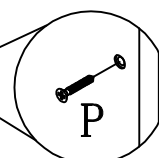
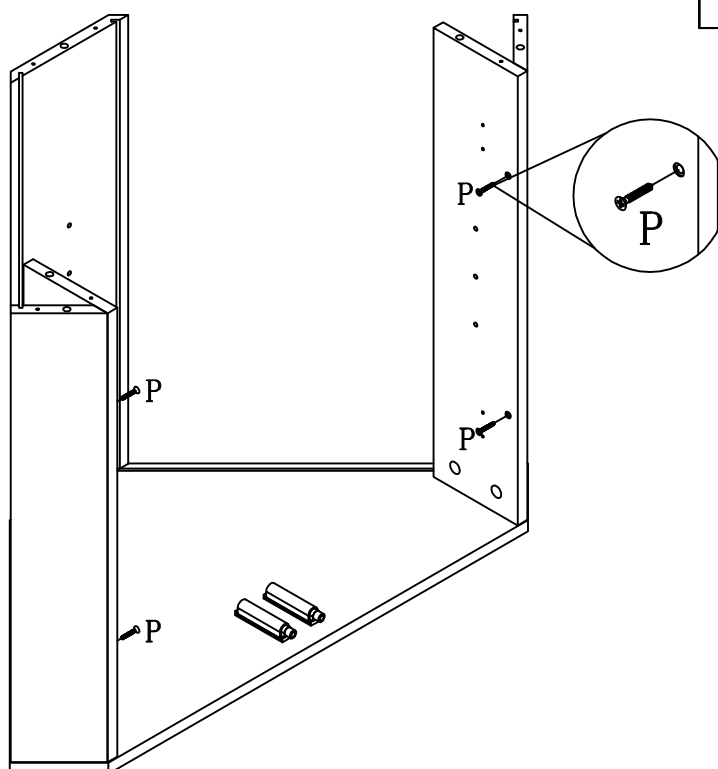
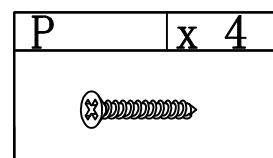

Step 5

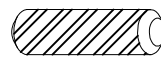
C	x 5
	

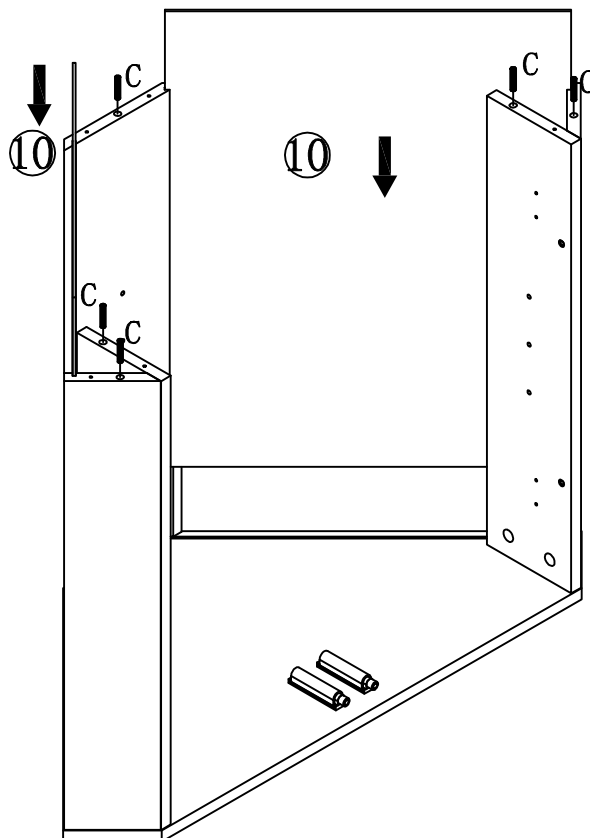

Step 6

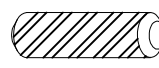
C	x 3
	

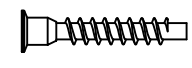
M	x 3
	

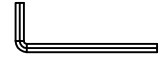
Q	x 1
	

I	x 3
	

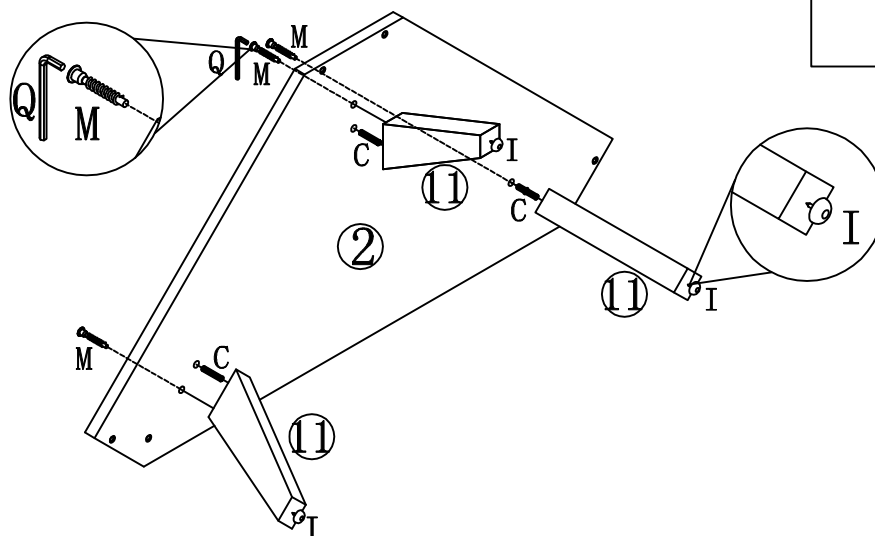

Step 7

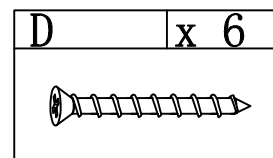
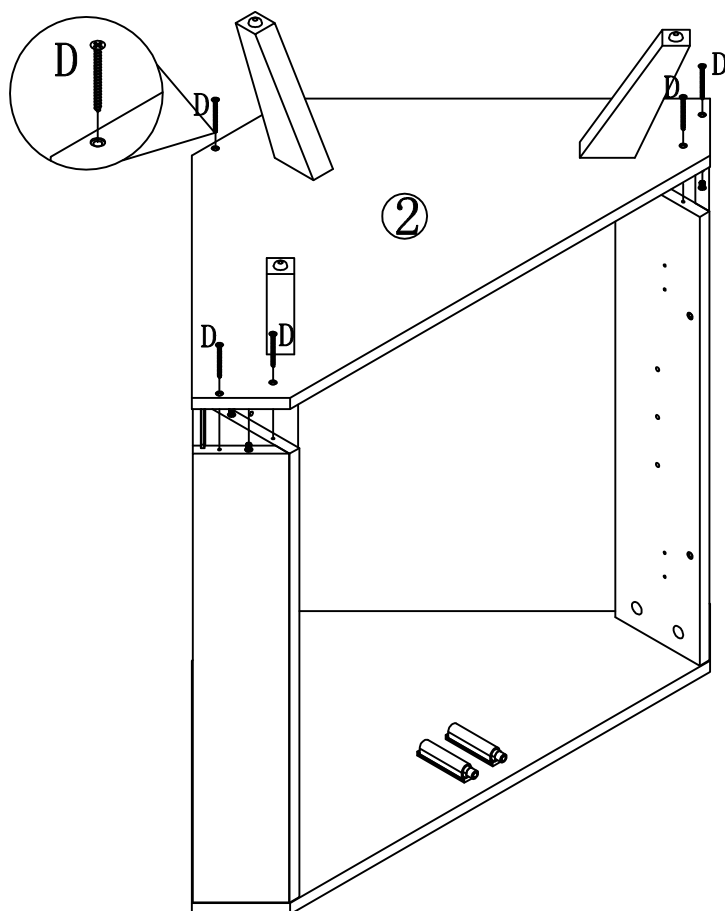

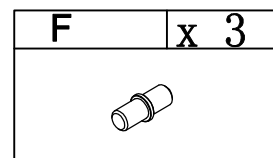
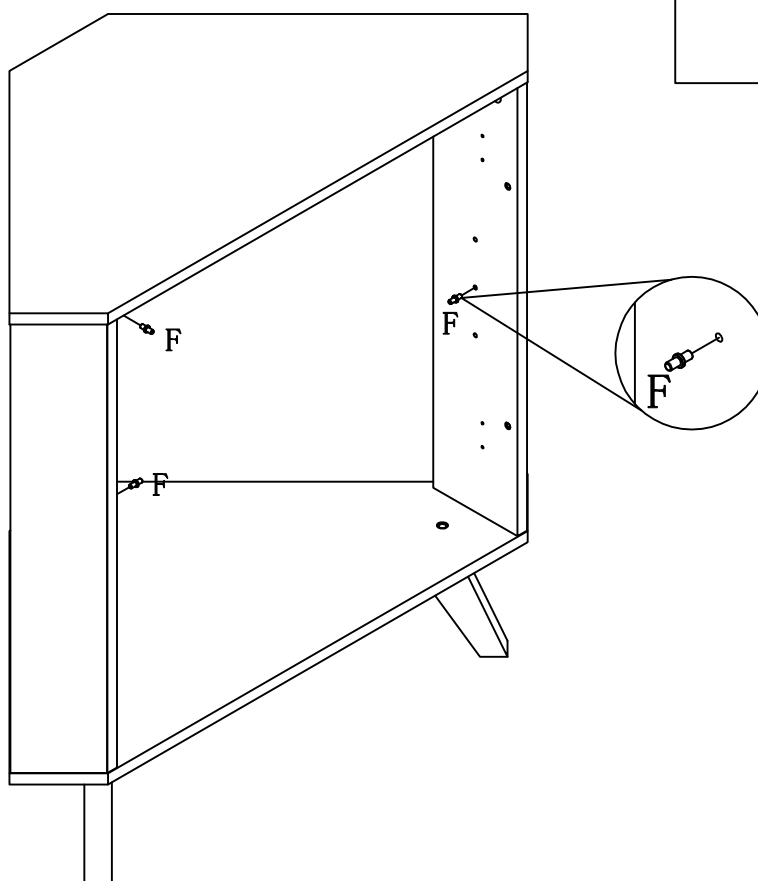

Step 8

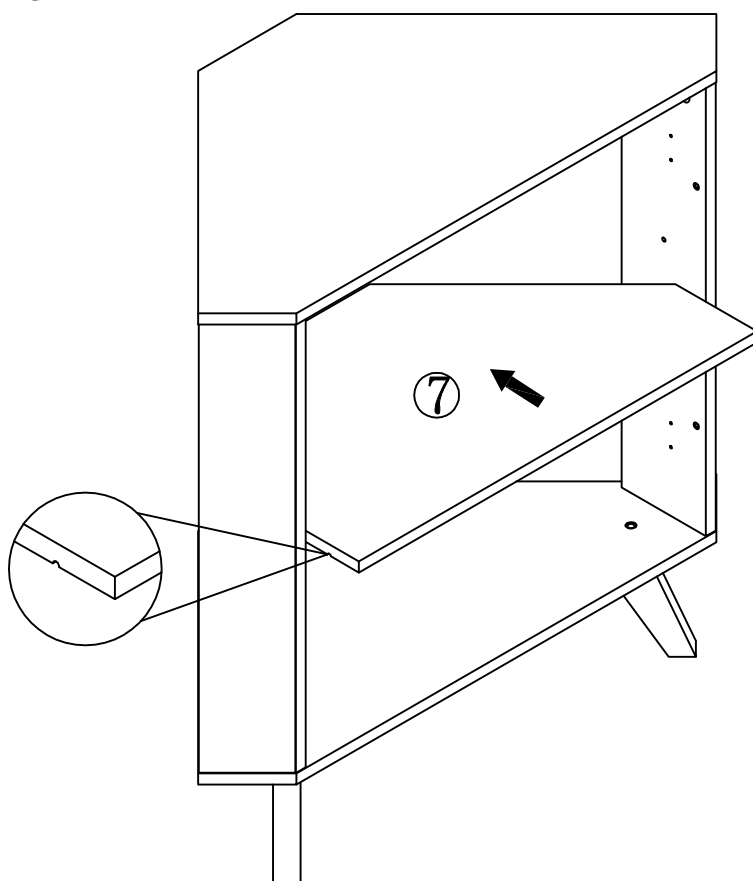

Step 9



Step 10

H	x 8	L	x 4
			

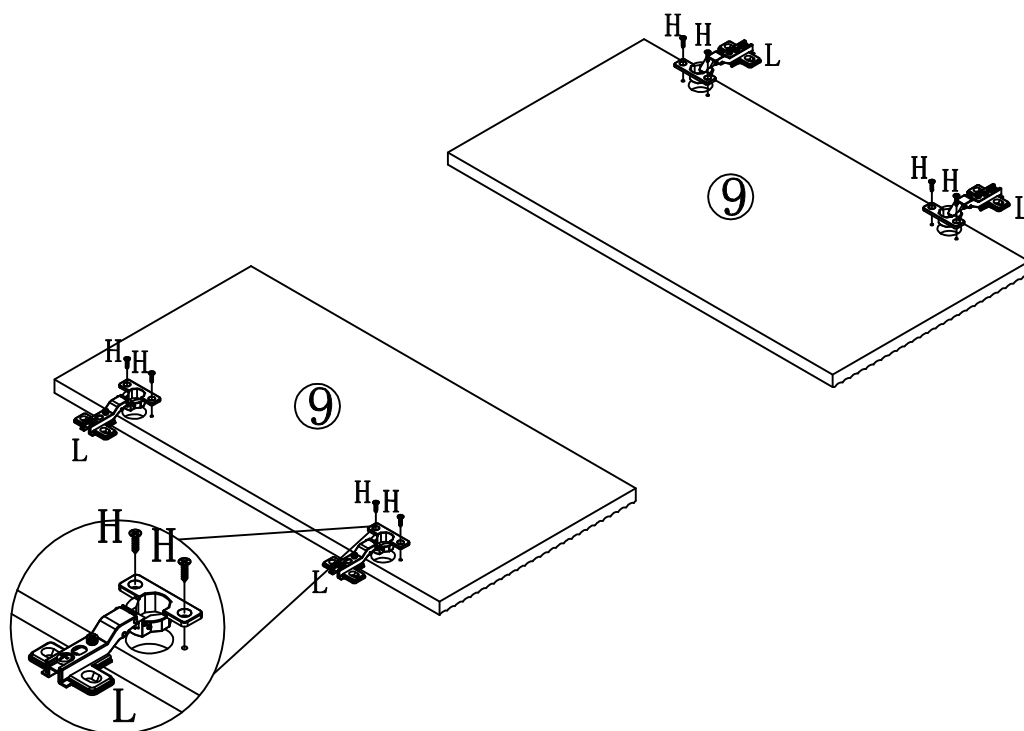



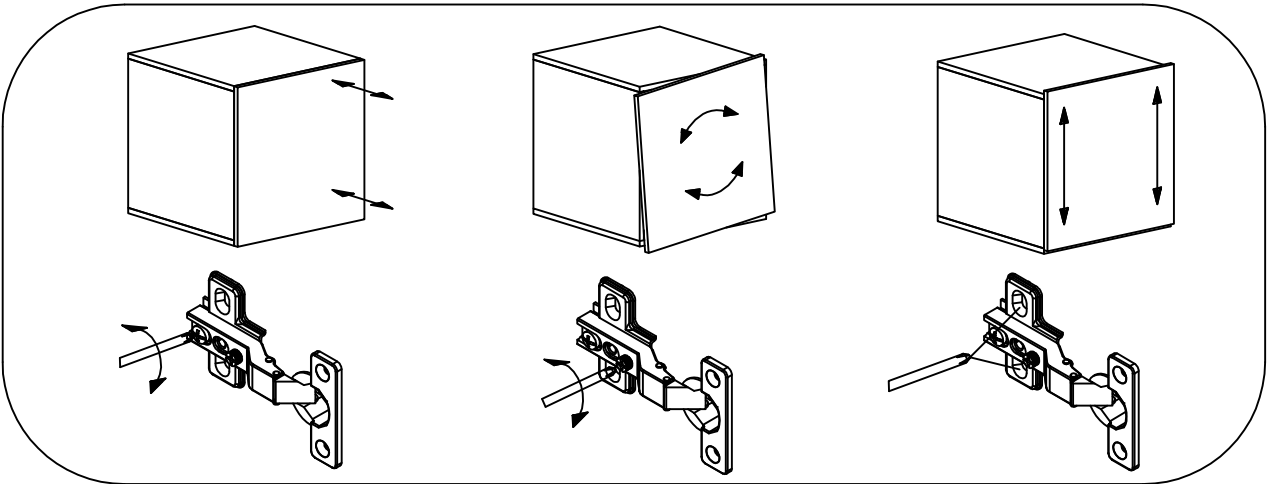
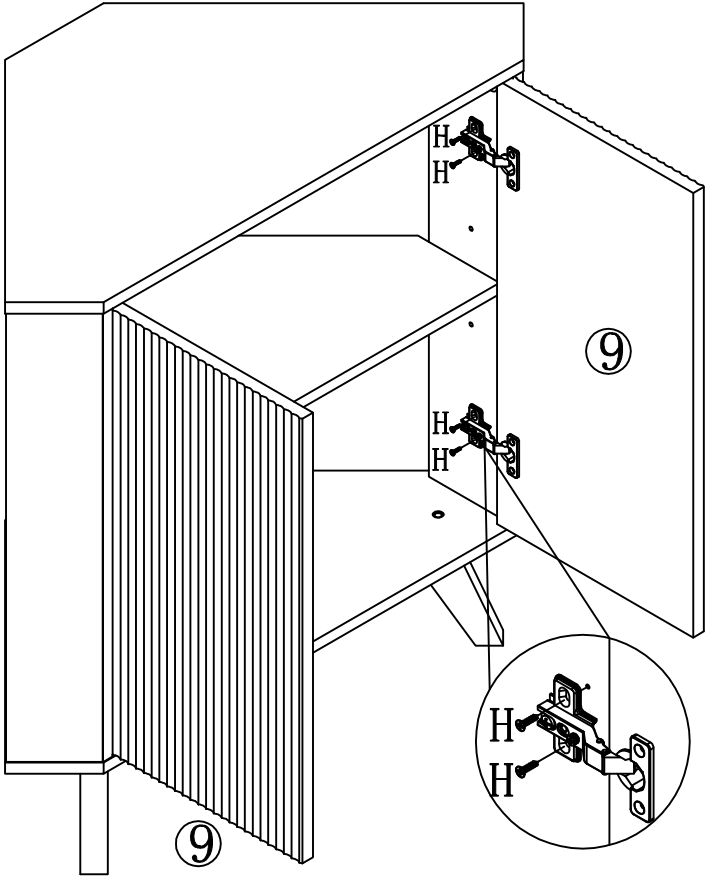

Step 11

H	x 8
	

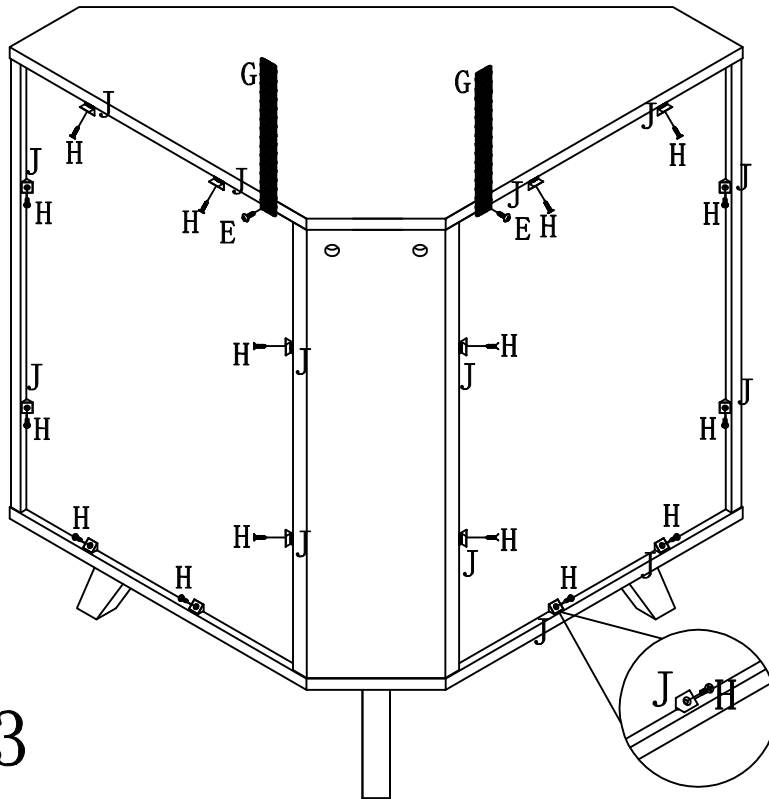

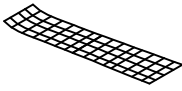

Step 12

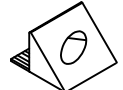

E	x 2
	
G	x 2
	
H	x 16
	
J	x 16
	

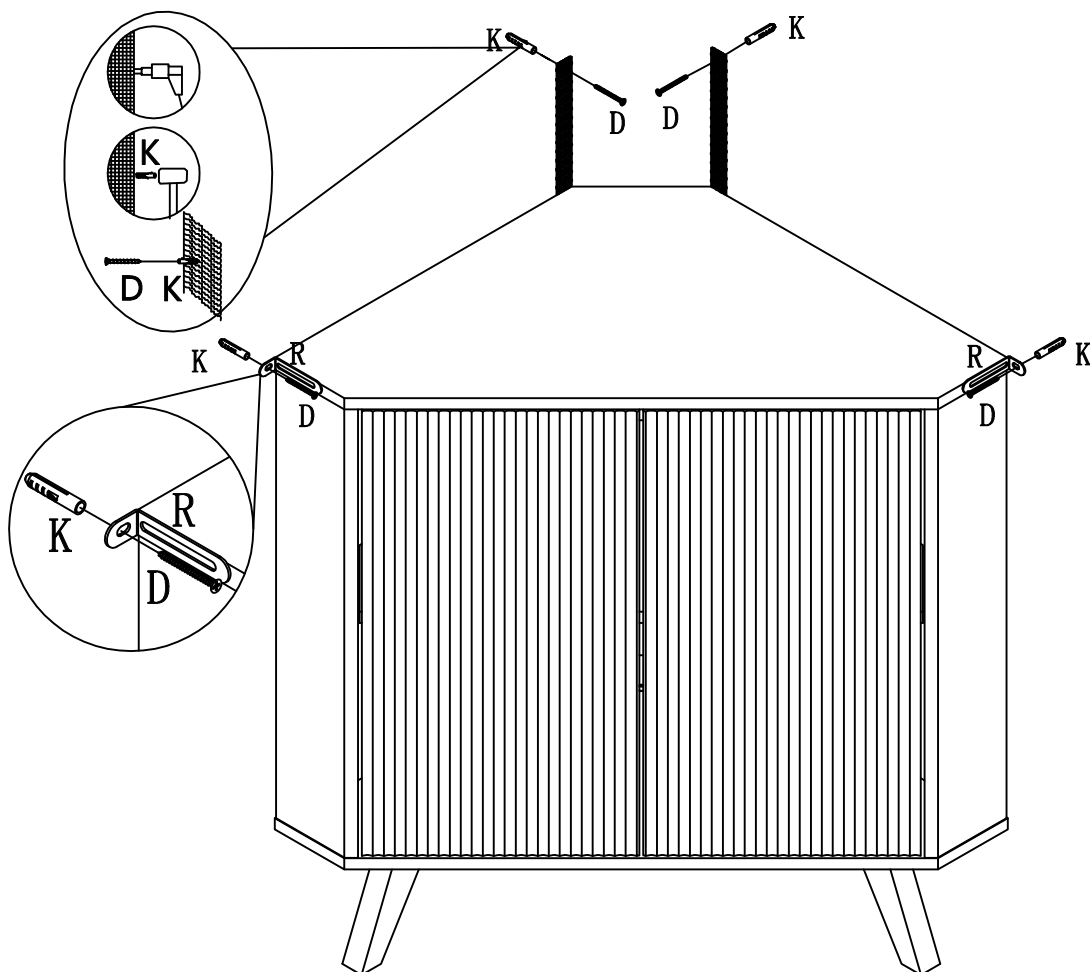
Step 13

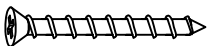

D	x 4
	
K	x 4
	
R	x 2
	

Step 14

E	x 2
