

Wood Room Divider

Instruction Manual for 3, 4, 6 & 8 Panel Sets

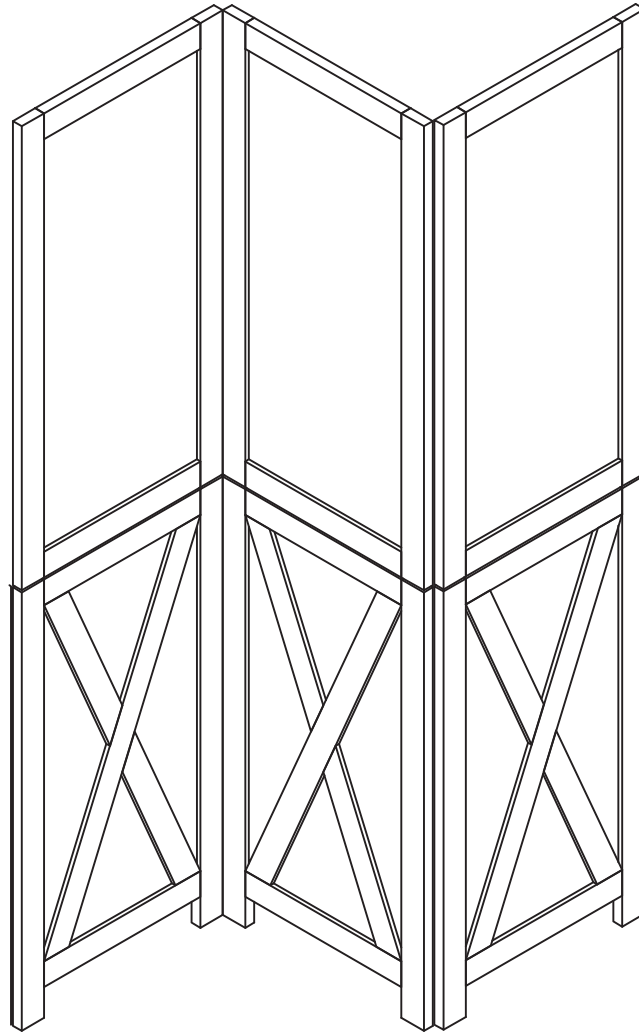

Contents

Before You Start

1.1 Product Overview	03
1.2 Important Safety Instructions	03
1.3 General Guidelines	03
1.4 Parts & Hardware List	04

Assembly Instructions

2.1 Installation Guide & Tips	04
2.2 Exploded View	05
2.3 Installation Steps	06

Care & Maintenance

3.1 Daily Cleaning & Care	08
3.2 Natural Material Variations	08
3.3 Troubleshooting	09

Contact & Warranty

4.1 Contact Information	10
4.2 Warranty Information	10

1.1 Product Overview

The Wood Room Divider combines elegant natural aesthetics with versatile functionality, offering a stylish solution for defining spaces and enhancing privacy. Its panel design allows for flexible configurations to suit any room layout, while the warm wood grain finish creates a sophisticated accent. Built for stability and everyday use.

1.2 Important Safety Instructions

Adult assembly required. Keep children and pets away during assembly.

Choking hazard: Keep small parts & plastic packaging out of reach of children.

Suffocation hazard: Dispose of all plastic bags immediately.

Do not allow children to climb on or play with the room divider.

Ensure the divider is fully stable and positioned on a flat surface before use.

WARNING: STABILITY HAZARD

- Do not hang heavy items (e.g., coats, bags) on the panels, as this can cause the divider to tip over.
- For maximum stability on any surface (including plush carpet, hardwood, or tile), do not exceed a 135° between panels. While the panels can fold up to 180°, angles above 135° significantly reduce stability.

1.3 General Guidelines

Read all instructions carefully before assembly and retain manual for future reference.

This product is designed for indoor use only.

Assemble on a soft, clean surface to prevent scratches.

The manufacturer is not liable for damage or injury caused by improper assembly or misuse.

Configuration may vary by panel set (3/4/6/8). Refer to the parts list for your specific model.

For additional support, scan the QR code for the assembly video or contact customer service.

1.4 Parts & Hardware List

Part Name	3-Panel Set (Qty.)	4-Panel Set (Qty.)	6-Panel Set (Qty.)	8-Panel Set (Qty.)
Panel	3	4	6	8
Screw	6	8	12	16
Hex Key	1	1	1	1

Note: Screw quantities vary by panel set. The following assembly steps use a 3-panel set for demonstration.

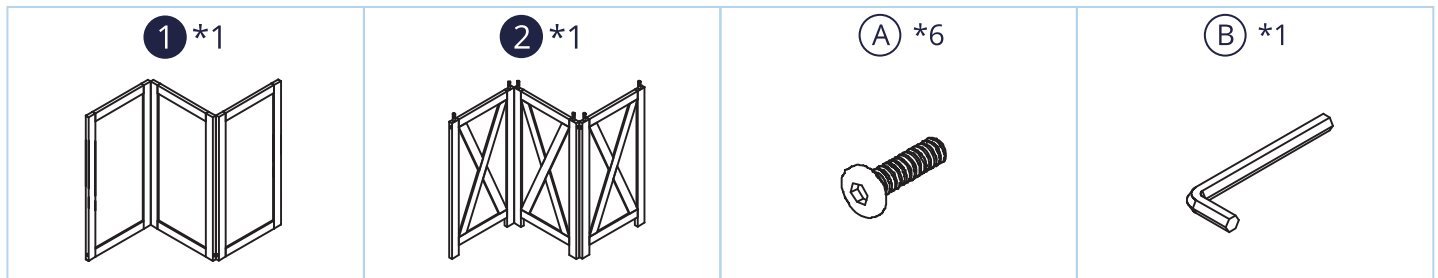

2.1 Installation Guide & Tips



Time



1 People

- Read all instructions carefully before beginning and keep this manual for future reference.
- Check the Parts List to ensure you have all components before starting assembly.
- Do not discard any packaging until assembly is complete to avoid accidentally discarding small parts or hardware.
- We recommend performing the assembly on a soft, clean, and flat surface (e.g., carpet) to prevent scratches.

Tips

During assembly, first align all screws with their pre-drilled holes, then tighten them gradually and evenly. We recommend having a second person assist you.

2.2 Exploded View

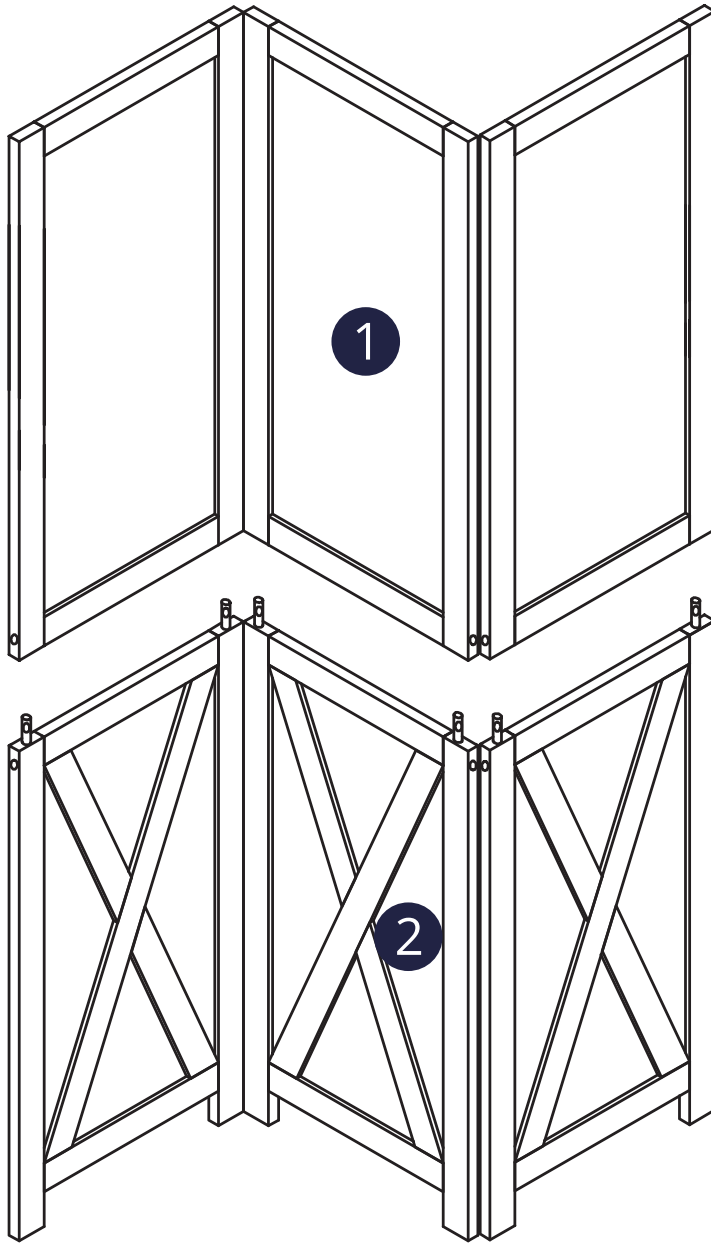

2.3 Installation Steps

Step 1

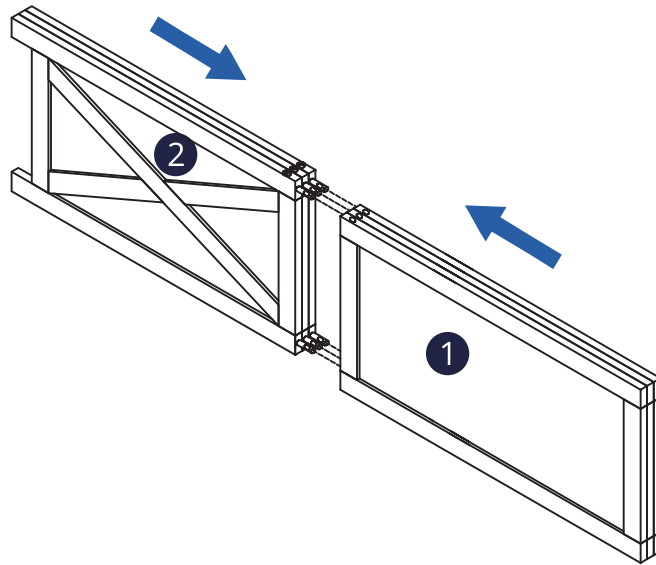

Step 2

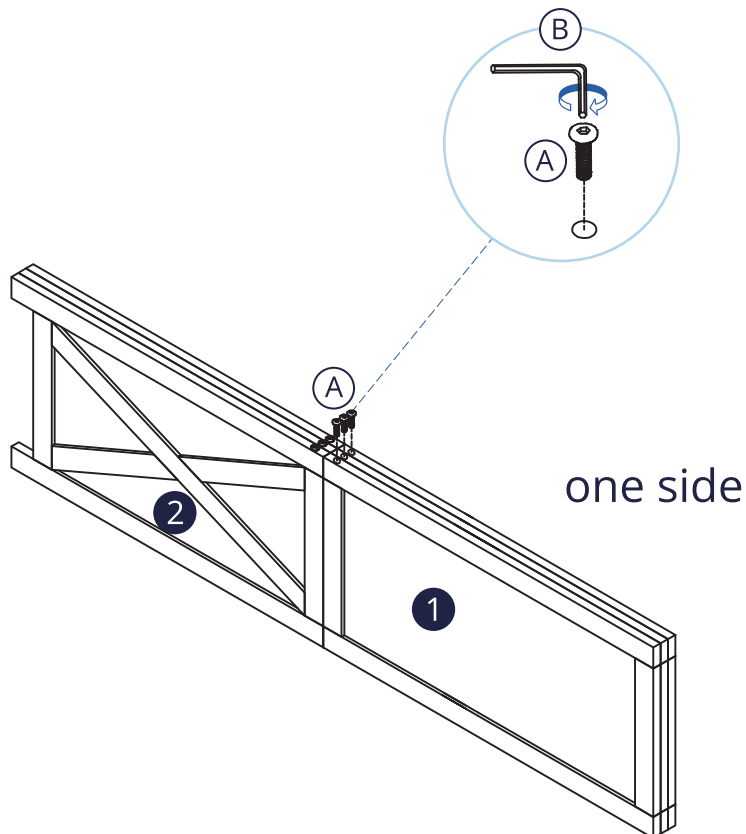

(A)  x 3 PCS

Installation Steps

Step 3

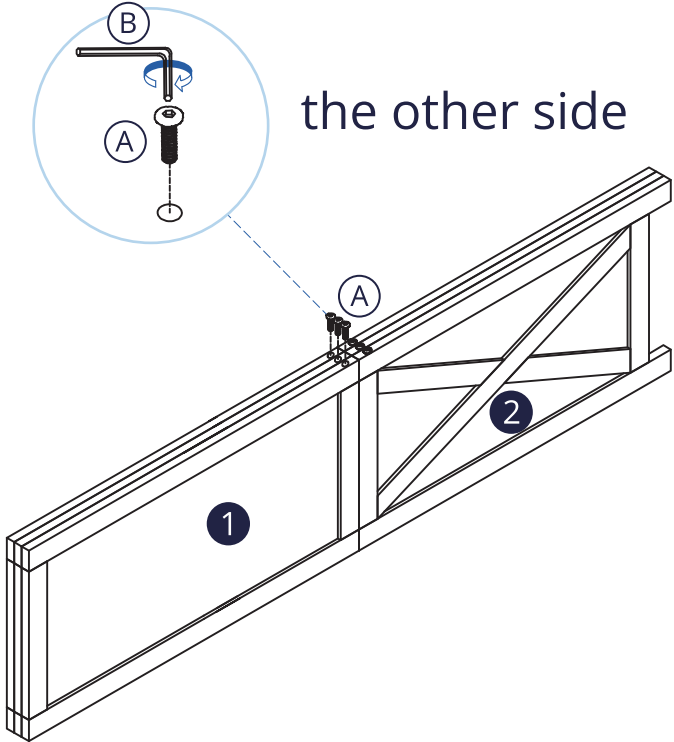

(A)  x 3 PCS

Step 4

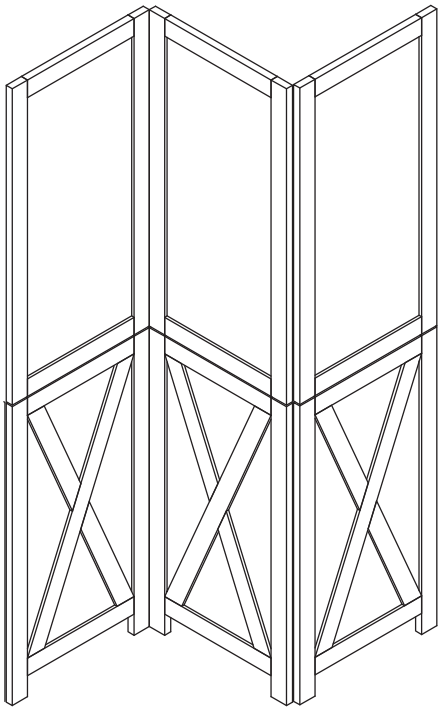

Done!

3.1 Daily Cleaning & Care

Cleaning

Dust Regularly

Gently wipe the wood surfaces with a clean, dry, soft cloth (such as a microfiber cloth) to remove dust.

For Smudges

If needed, lightly dampen the cloth with water and wipe the surface, then immediately dry with another clean cloth.

Avoid Moisture

Do not use excessive water or wet cloths for cleaning, as this may damage the wood finish.

Avoid Cleaners

Do not use abrasive cleaners, harsh chemicals, or silicone-based sprays on the wood.

Environmental Care

Keep the screen away from direct sunlight and heat sources to prevent fading or warping over time.

3.2 Natural Material Variations

Wood

Celebrate the unique character of natural wood. Each panel features a distinctive grain pattern with its own subtle color variations and occasional mineral streaks. These are not flaws—they are the wood's authentic signature.

As light shifts across the surface, you may notice gentle tonal changes that enhance its organic appeal. This elegant responsiveness is a natural quality of solid wood, valued for its inherent beauty and lasting durability.

Thoughtful Joinery & Finish

Crafted for both beauty and function, the panel frames are joined with precision-cut connectors for smooth folding and long-term stability. The natural wood finish is designed to protect and enhance the grain, allowing the true character of the wood to shine through with a soft, matte luster.

3.3 Troubleshooting

Symptoms	Cause Analysis	Solution
Screen is unstable or wobbles	The panels are not properly unfolded and locked into a stable position, or the floor is uneven.	Gently adjust the angle between panels to distribute weight evenly. For uneven floors, use the provided self-adhesive felt pads on the bottom of the feet to stabilize.
Panels are difficult to fold or unfold	The connecting hinges may be too tight, or debris may be trapped in the mechanism.	Ensure the screen is on a flat surface. Loosen the hinge screws slightly, adjust the panels, then retighten. Check for and remove any small obstructions.
Gap between panels or misalignment	The hinge screws have become loose over time.	Fully extend the screen on a flat surface. Check and tighten all hinge screws with the provided hex key.
Scratches on wood surface	The wood finish has been scratched by sharp or abrasive objects.	For minor scratches, use a matching wood touch-up pen or a small amount of beeswax. Apply gently to the affected area and buff with a soft cloth.
Panel appears warped or not perfectly flat	Natural wood may respond to significant changes in humidity and temperature.	This is often temporary. Move the screen to a room with stable humidity. If the warping is pronounced and persistent, please contact our customer service.

4.1 Contact Information

We're Here to Help!

Your satisfaction is our priority. Please contact us directly before initiating a return to ensure the fastest resolution and avoid unnecessary shipping costs.

Contact Us Easily:

Go to "Your Orders".

Locate your order and select "Contact Seller".

Please have your Order ID ready for efficient service.

4.2 Warranty Information

This product is backed by a 1 -year limited warranty against manufacturing defects. For full warranty terms and conditions, please visit our website