

DIRECTORY

PRODUCT INTRODUCTION

Instructions for use

Product features

Product placement and installation

USE

Usage guide

CLEANING AND MAINTENANCE

Cleaning instructions

PRODUCT WARRANTY GUIDE

Range

Warranty period

Warranty content

Warranty process

INSTRUCTIONS FOR USE

TURN THE HANDWHEEL SWITCH TO THE LEFT AND ADJUST THE TEMPERATURE TO PRODUCE COLD WATER, MIXED WATER, AND HOT WATER; TURN TO THE RIGHT TO TURN OFF THE WATER OUTLET MAIN SWITCH. THE LEFT BUTTON CONTROLS THE WATER OUTLET METHOD.

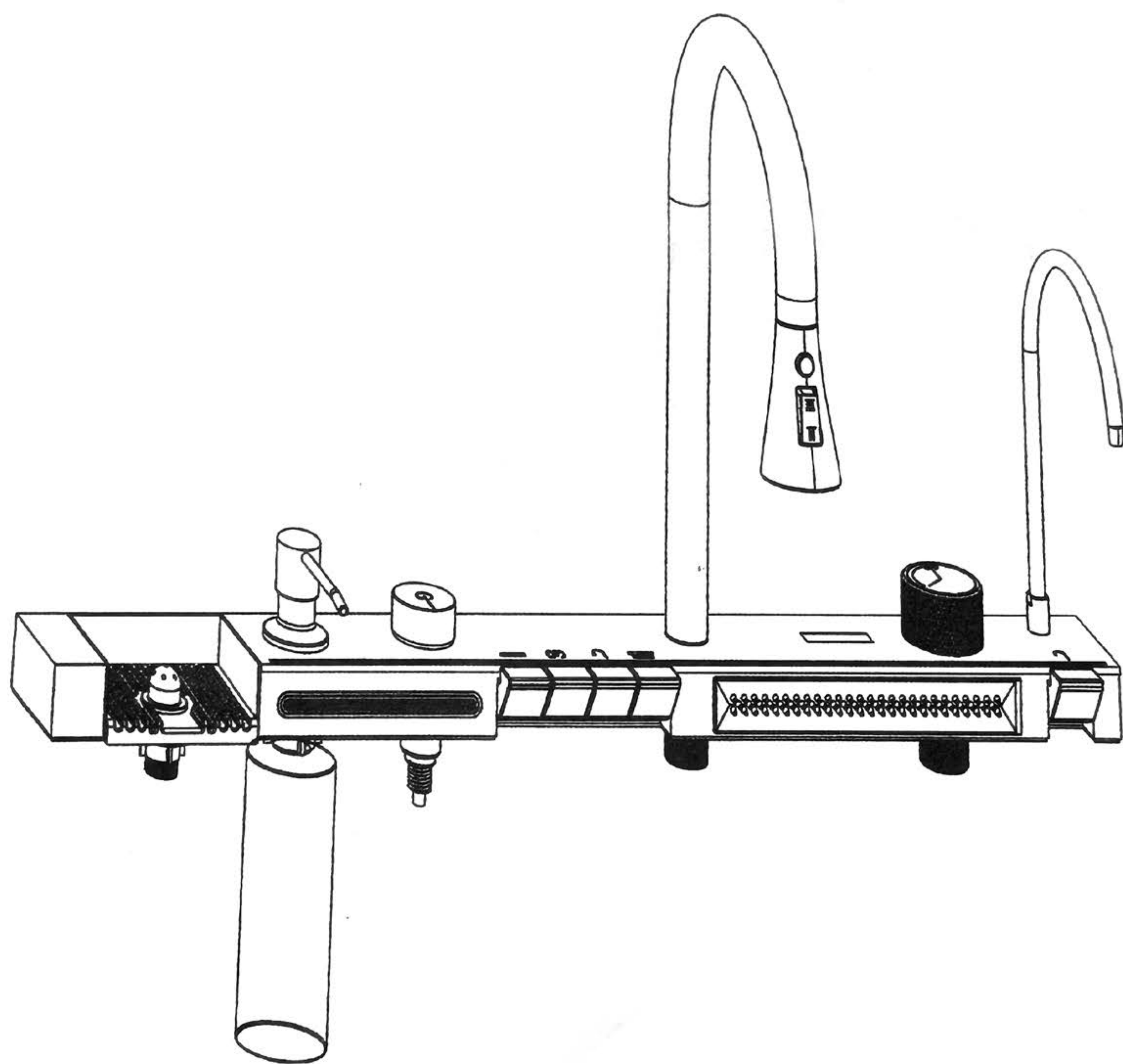

PRODUCT FEATURES

Adopting a series of noise reduction techniques to minimize noise.

Strong load-bearing capacity, no deformation after long-term use

Widening and thickening design

Industrial grade material, structurally stable

Corrosion resistant, water tight, and rust resistant

Oil proof, stain proof, moisture-proof, antibacterial

No need to wash by hand, just rinse it clean

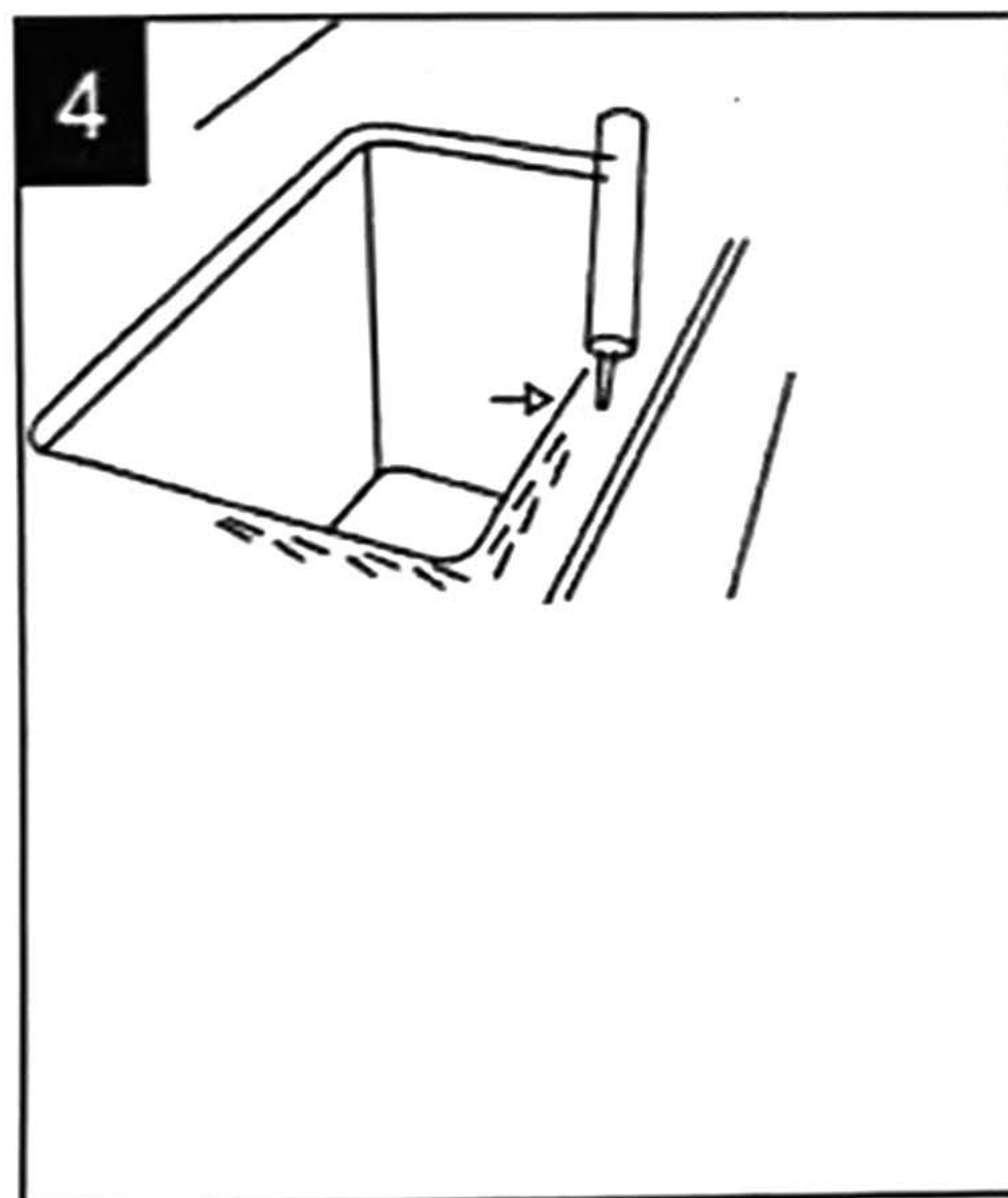
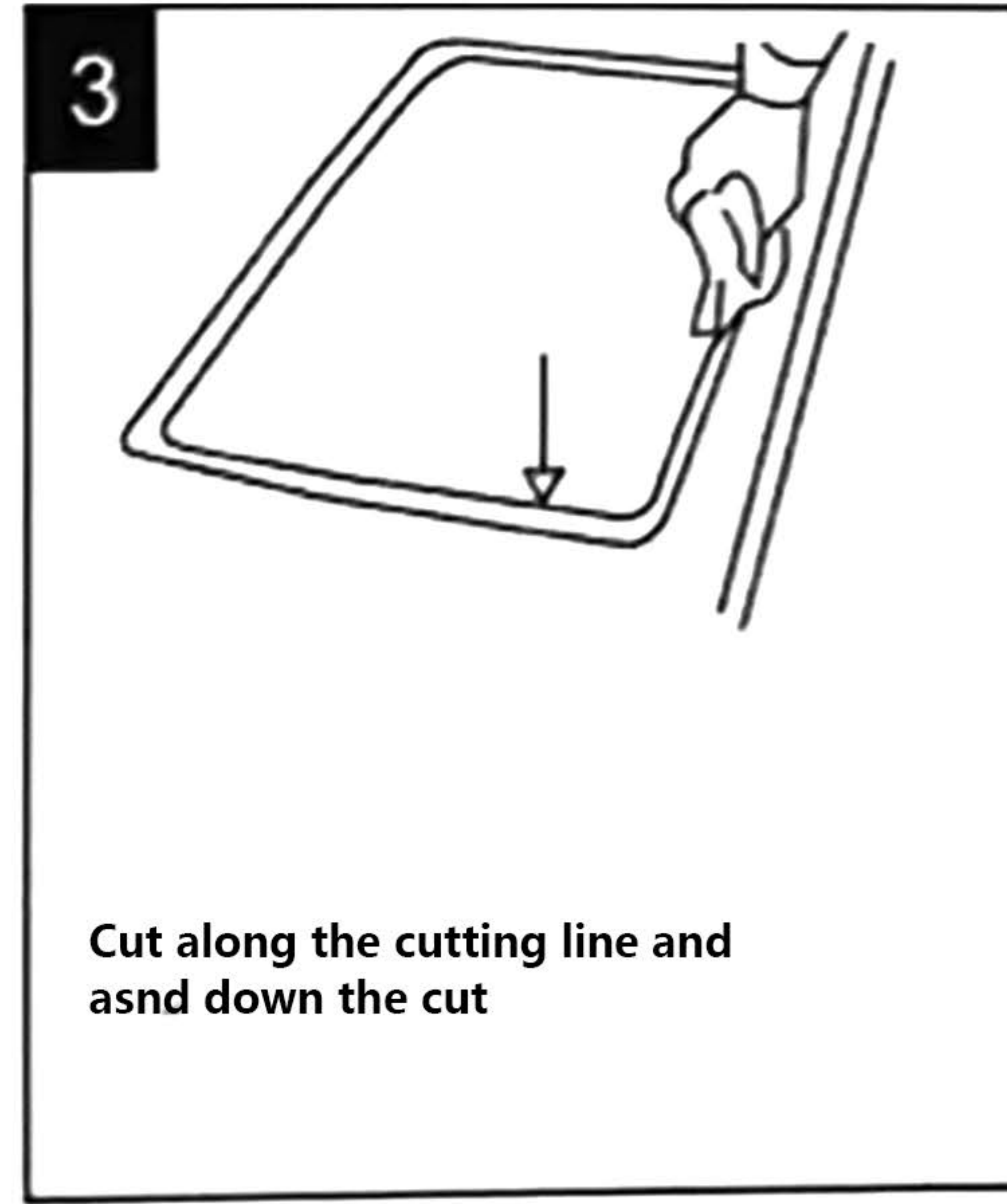
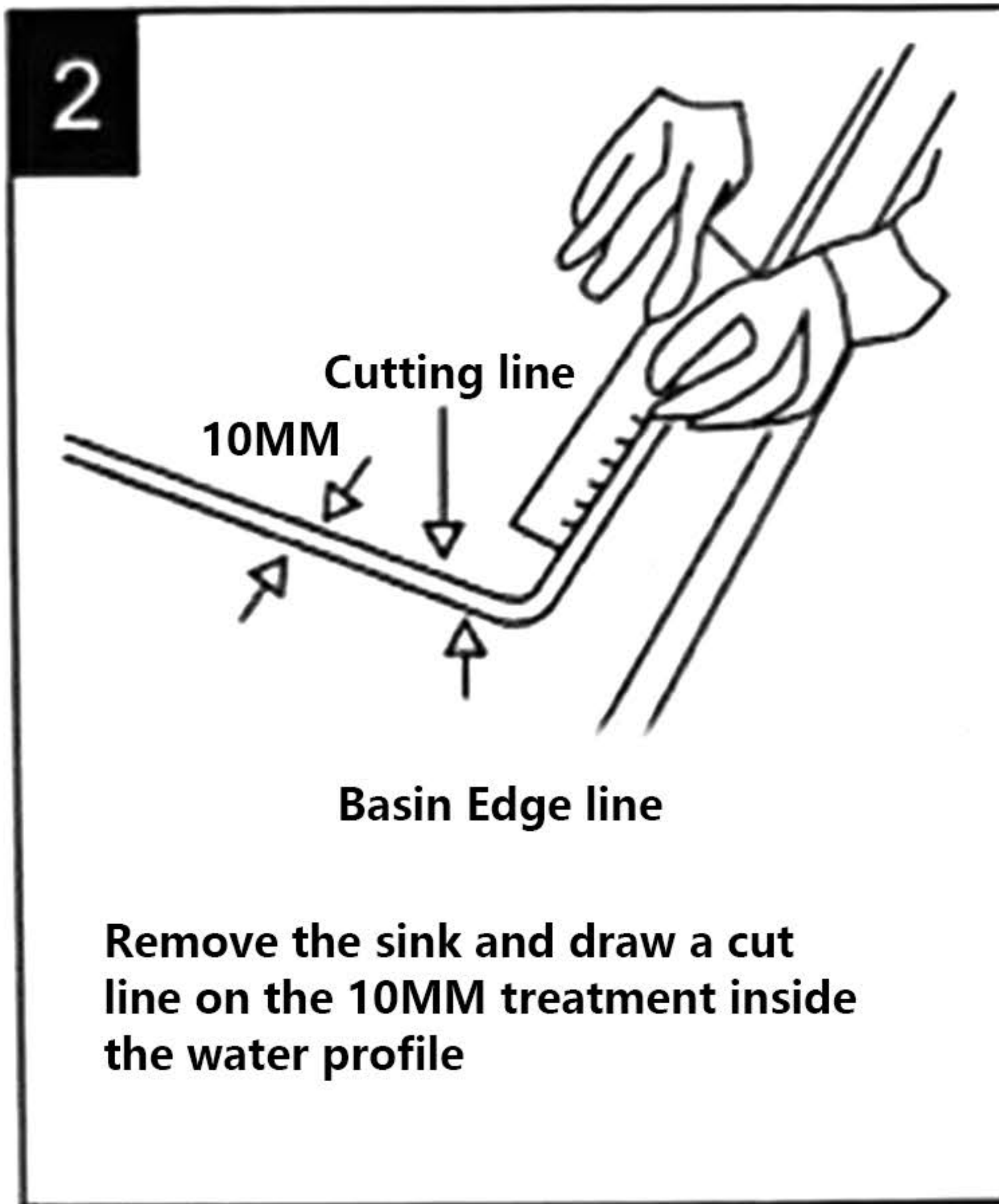
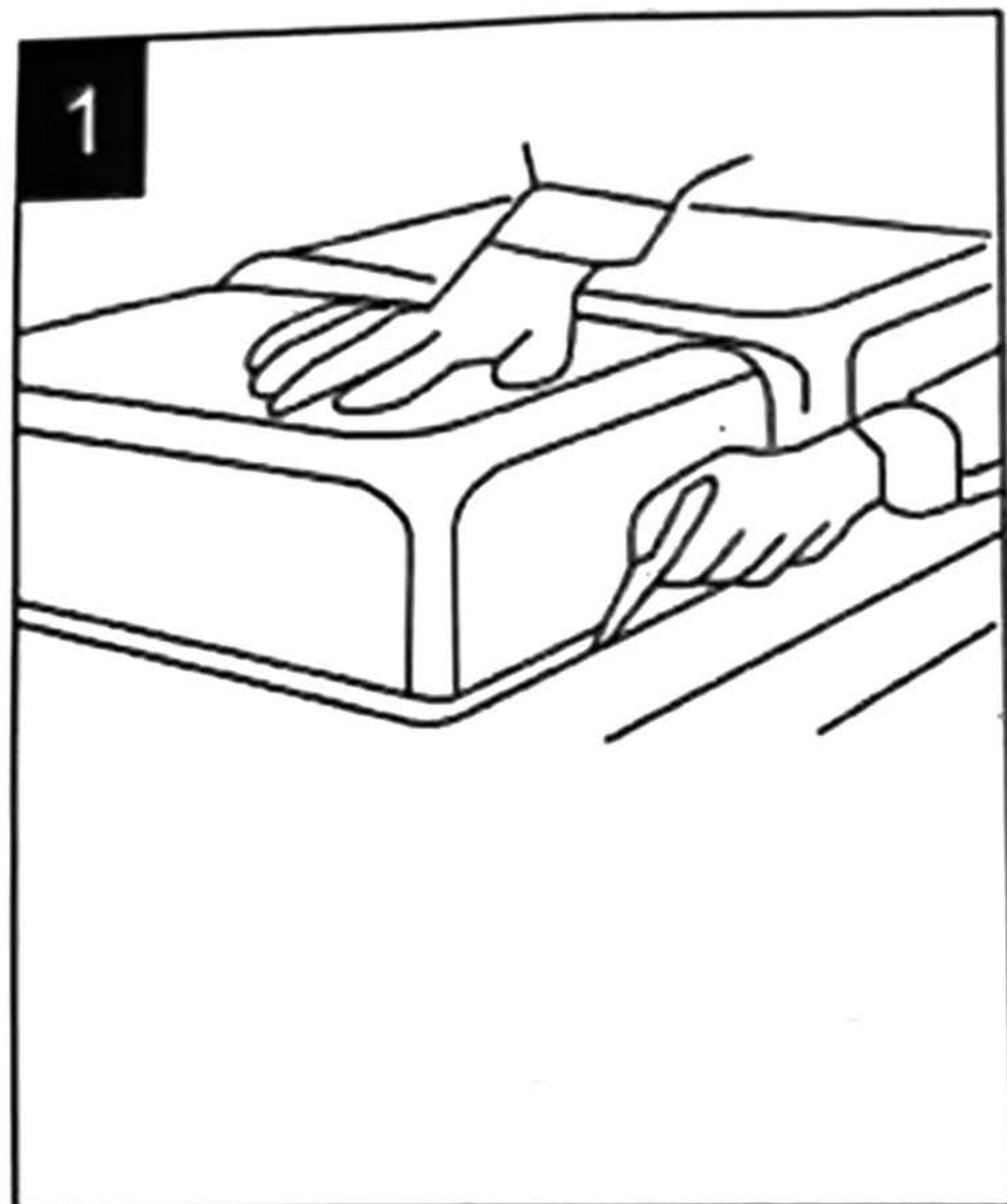

PRODUCT PLACEMENT AND INSTALLATION

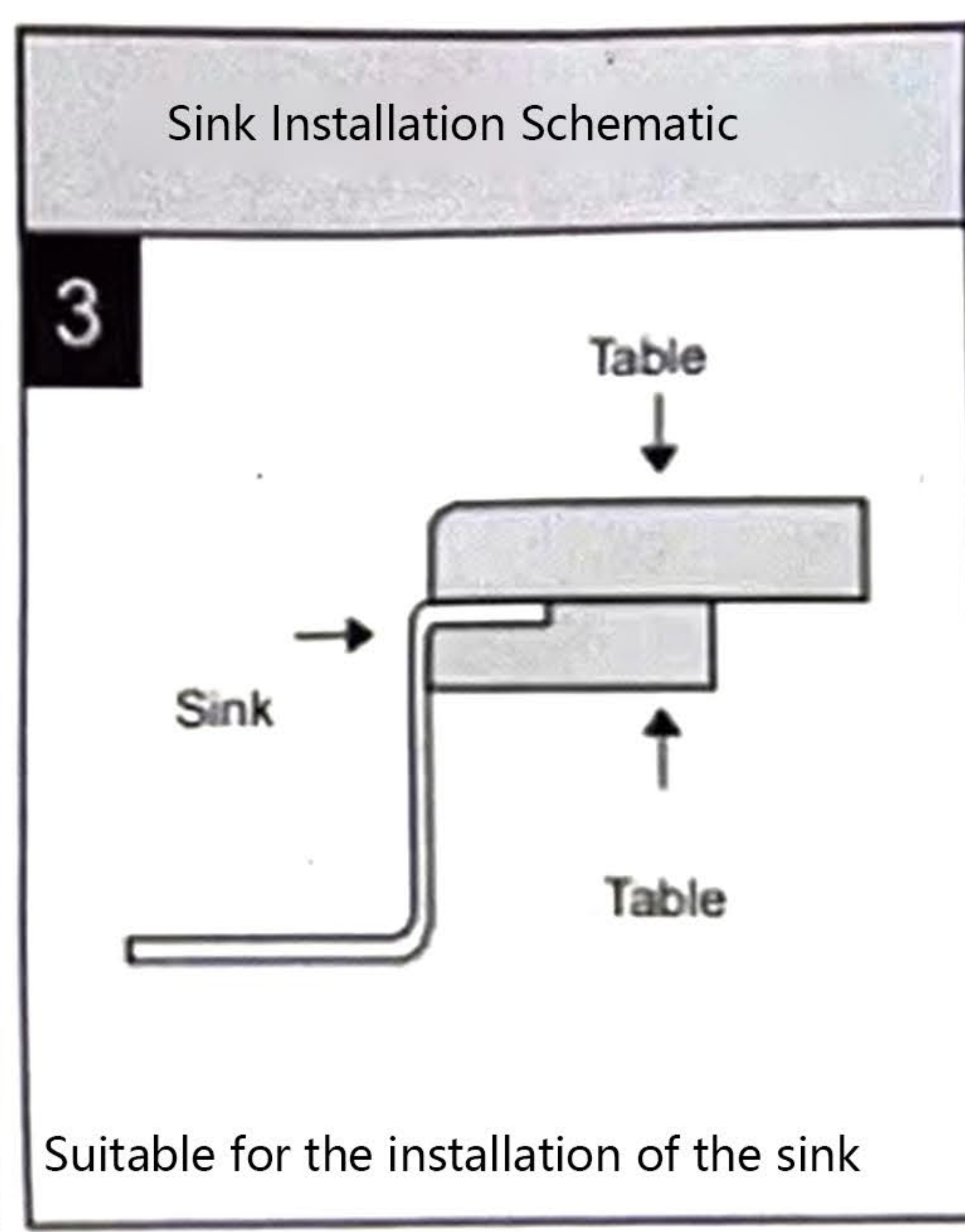
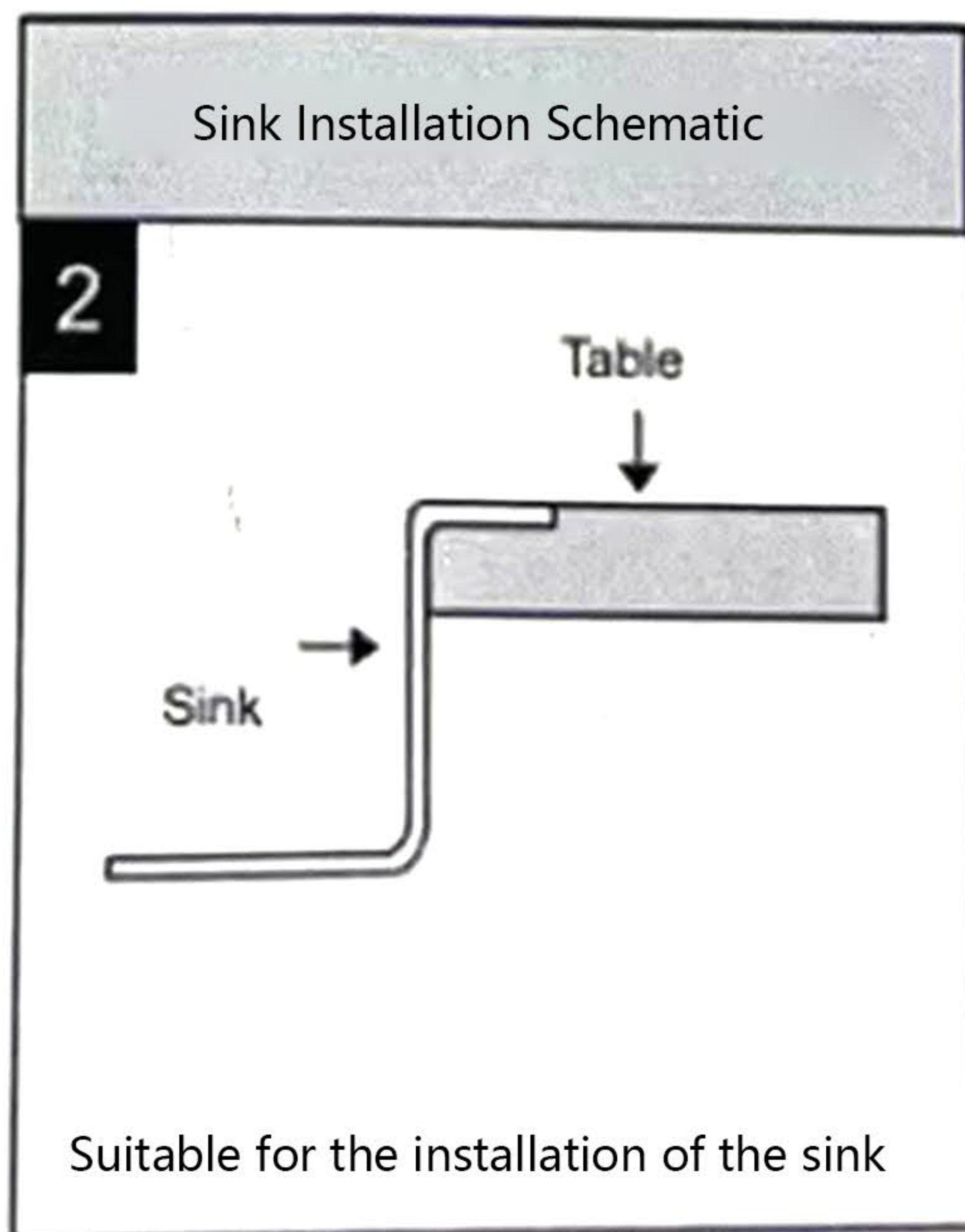
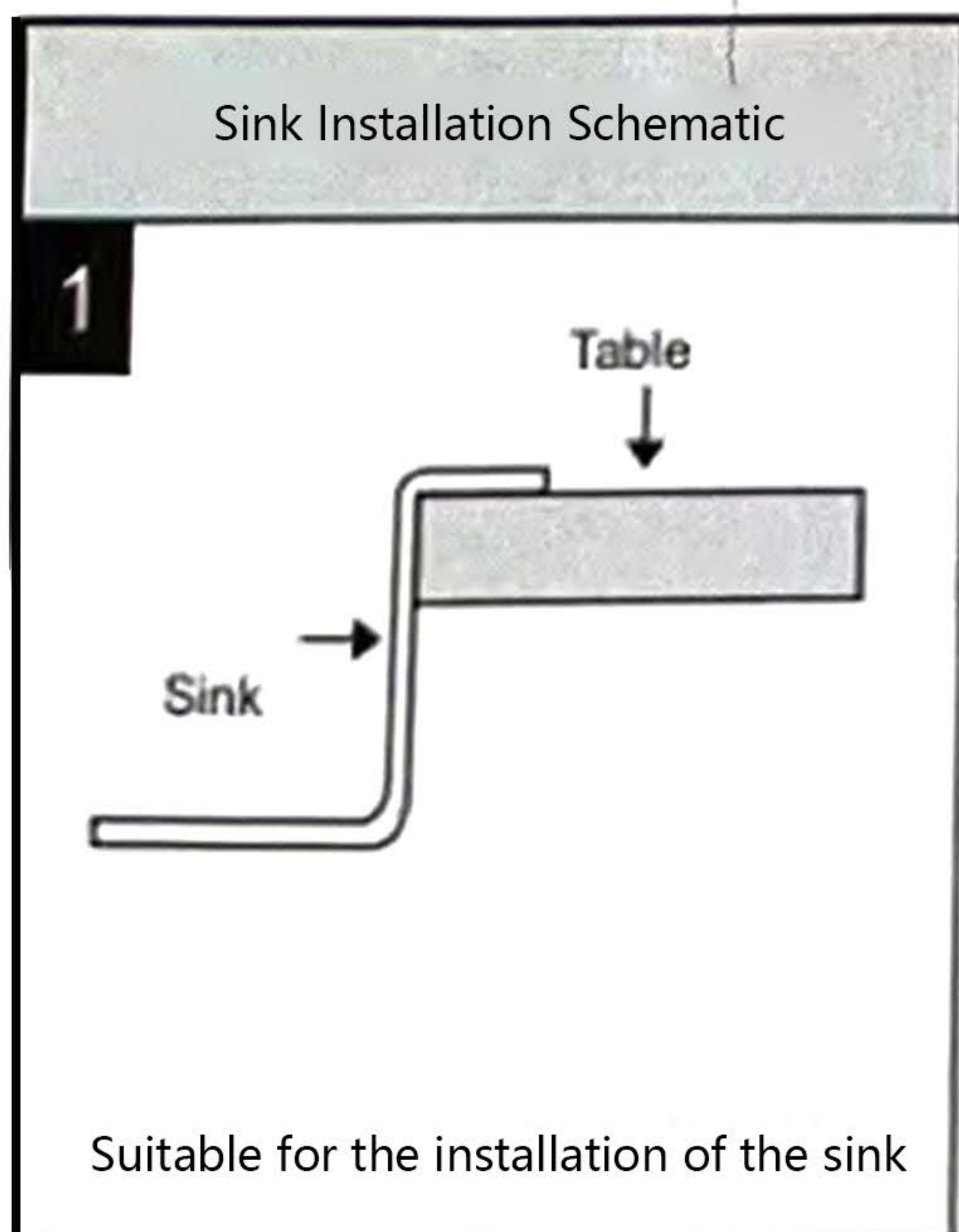

Npte: Figs.1and 2 fit the installation scheme of the flying rain futter ligs.3 do not recommend the installation of the platform basin

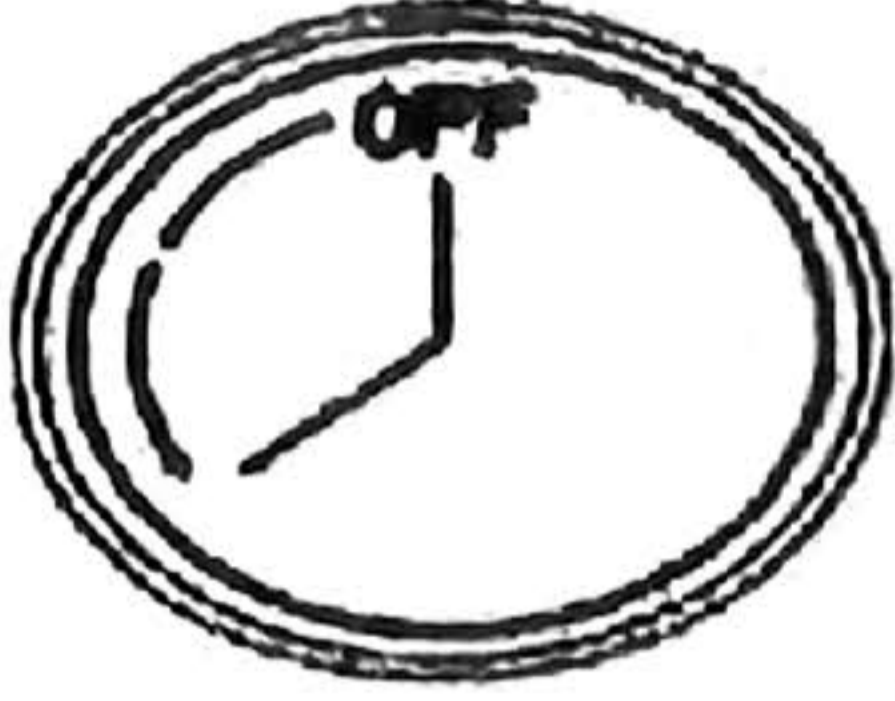
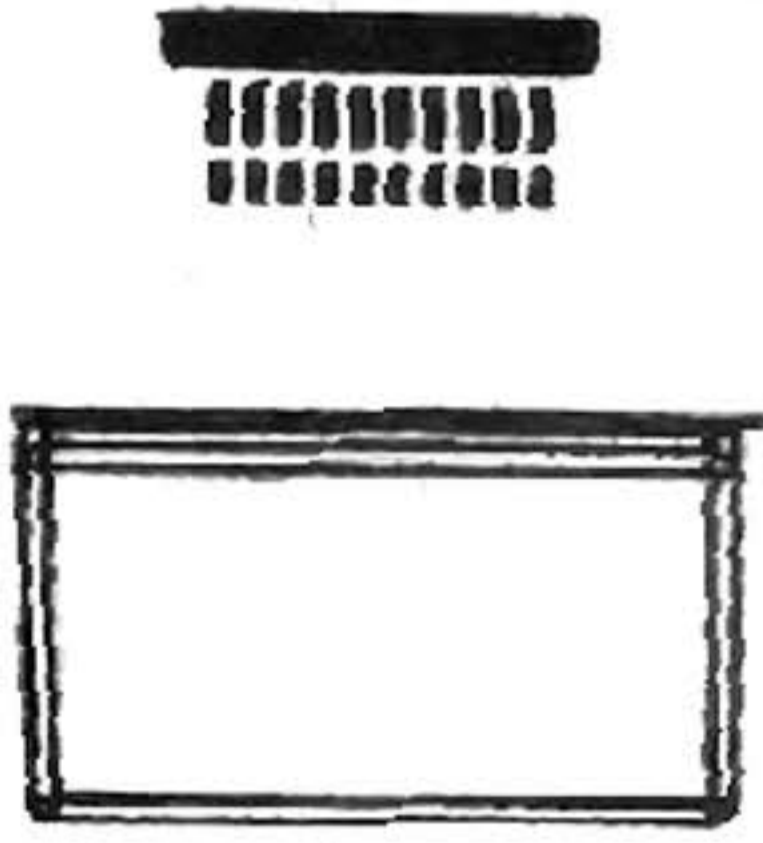
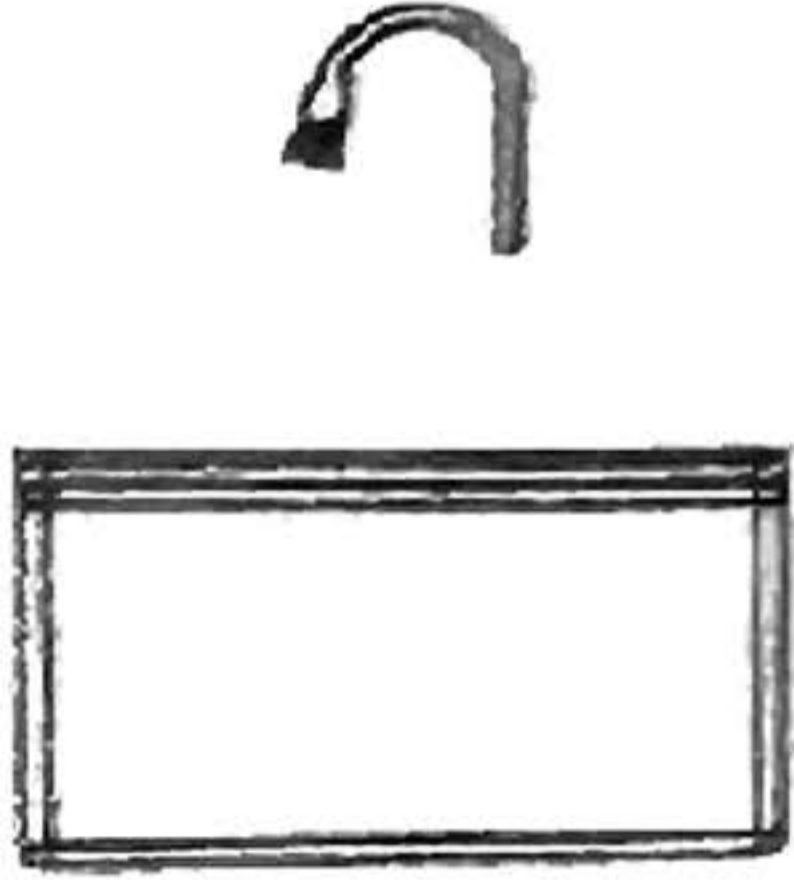
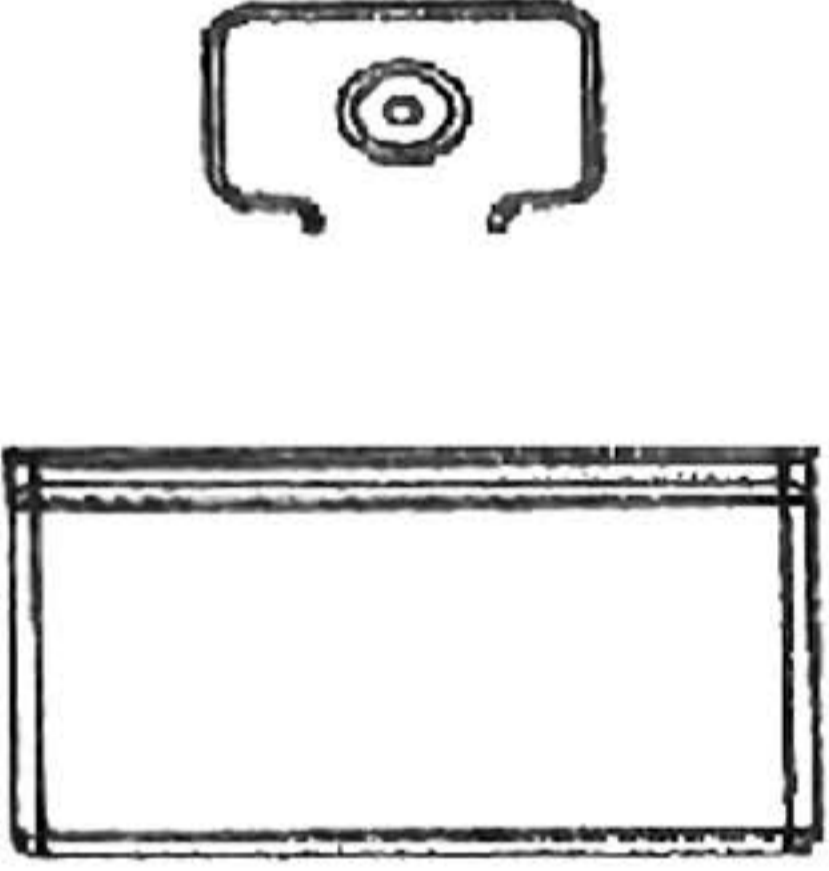
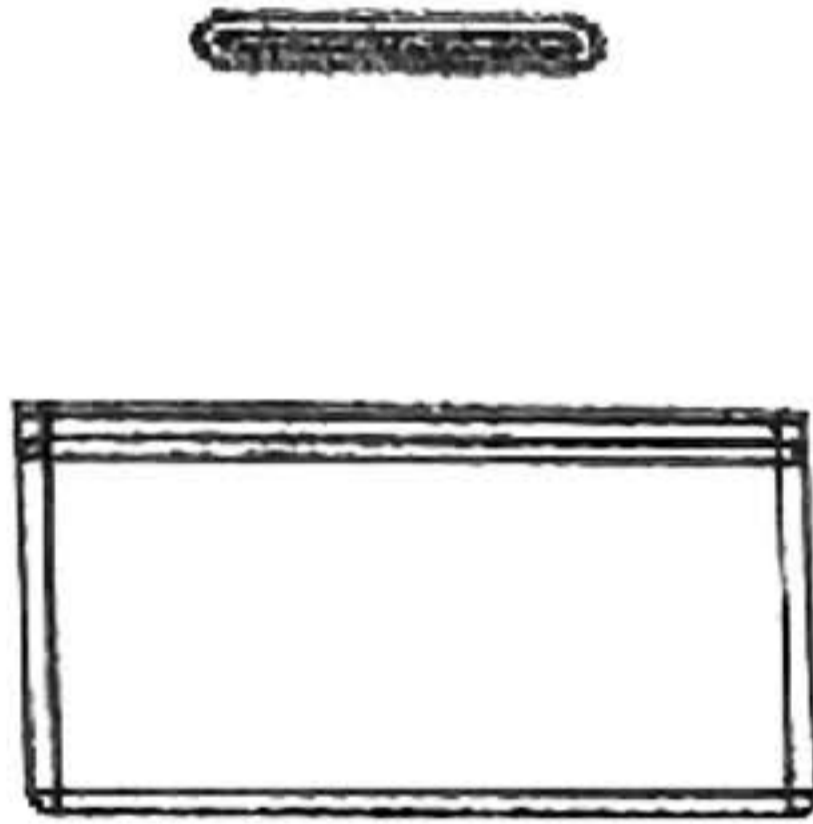
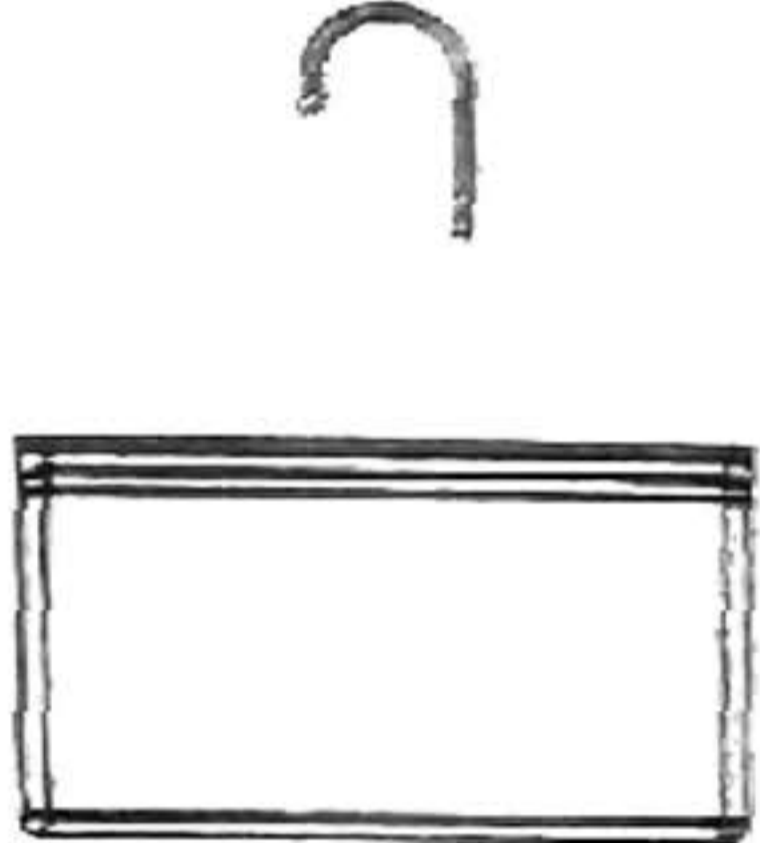
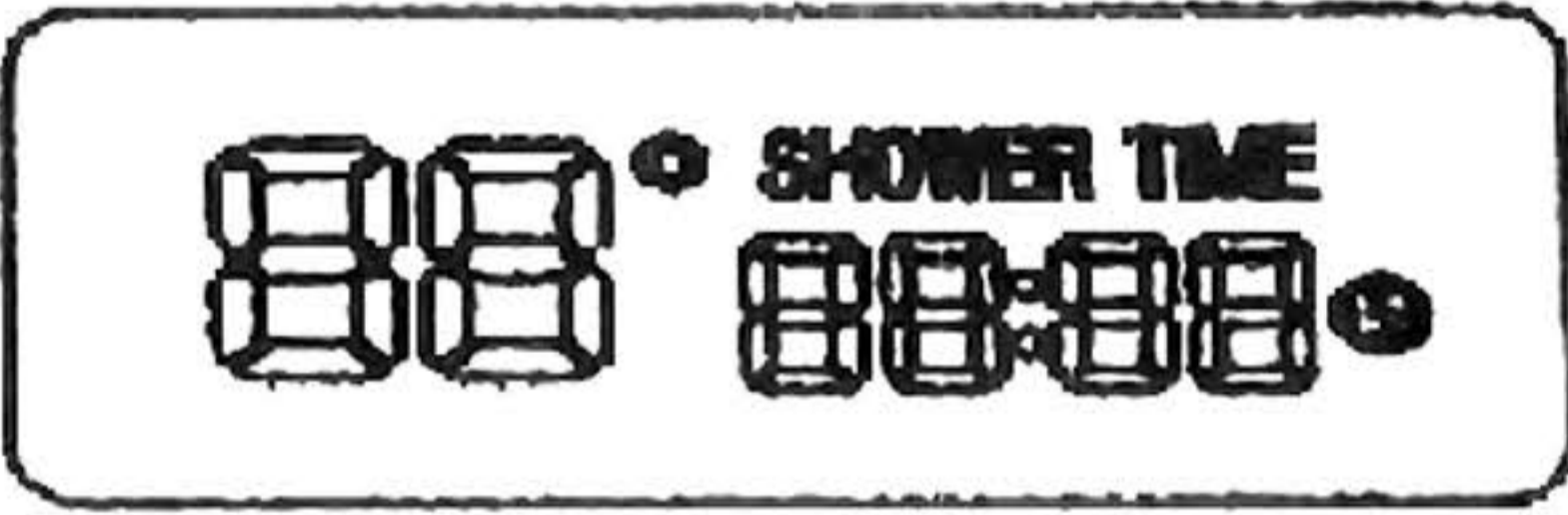

USAGE GUIDE

 <p>LEFT ROTATION FIXED TEMPERATURE, COLD WATER MIXED HOT WATER ROTATE RIGHT TO CLOSE</p>	 <p>WATERFALL WATER OUTLET BUTTON</p>	 <p>TAP WATER OUTLET BUTTON</p>
 <p>TAP WATER OUTLET BUTTON</p>	 <p>CUP WASHER WATER OUTLET BUTTON</p>	 <p>WATER PURIFIER OUTLET BUTTON</p>
 <p>SCREEN DIGITAL DISPLAY OF OUTLET TEMPERATURE AND OUTLET TIME</p>	 <p>CONSOLE CONTROL SWITCH KNOB</p>	 <p>SOAP DISPENSER PRESS</p>

INSTALLATION COMPLETION INSPECTION

CHECK AND ENSURE THAT ALL CONNECTIONS ARE TIGHTENED, ENSURE THAT THE HANDWHEEL IS IN THE CLOSED POSITION, OPEN THE MAIN WATER SOURCE AND DRAINAGE SYSTEM, CHECK AND REPAIR ANY LEAKING INTERFACES

CLEANING INSTRUCTIONS

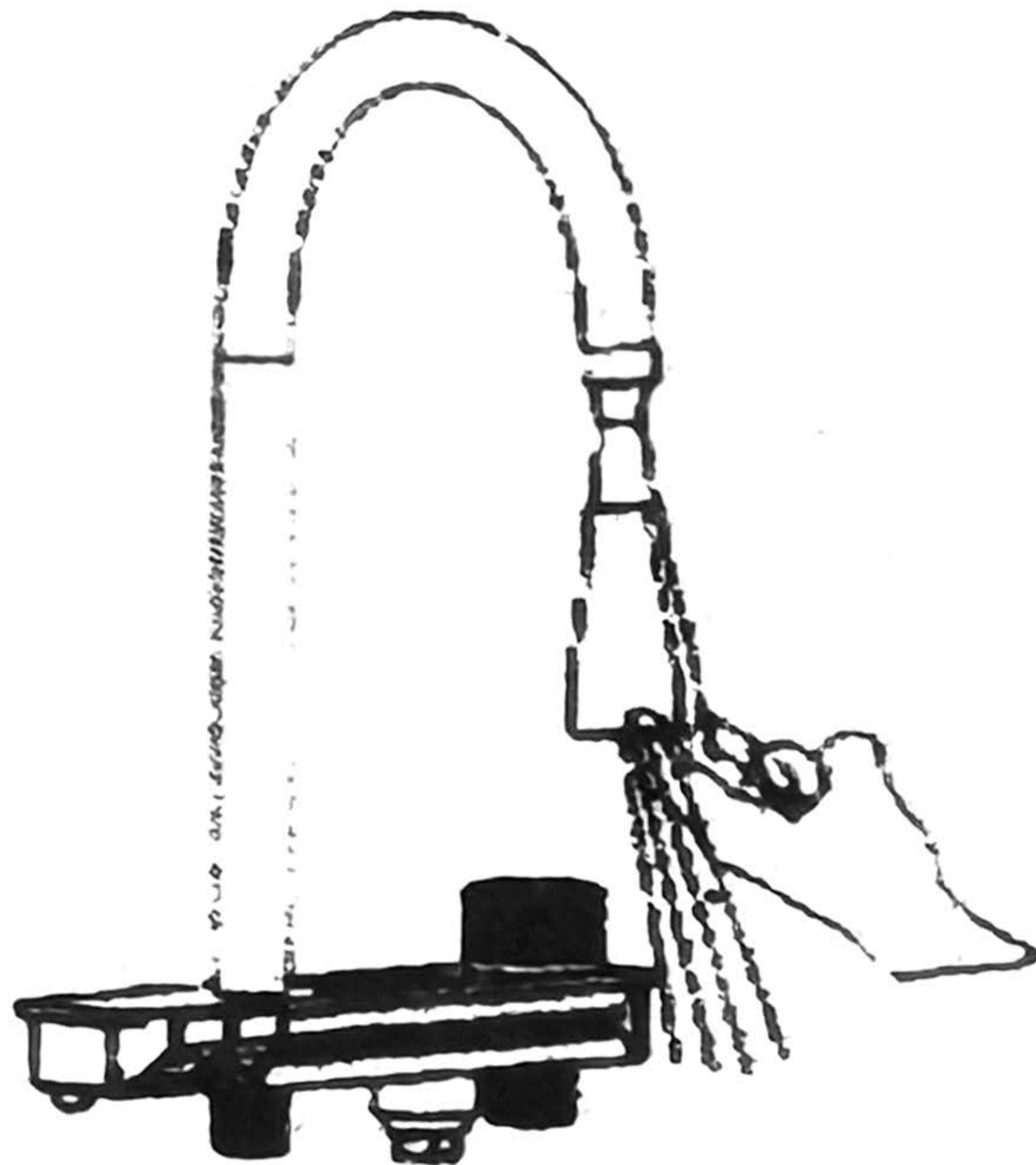

1. TURN ON THE FAUCET AND RUB THE NOZZLE TO REMOVE IMPURITIES

2. WHEN THE WATER FLOW DECREASES, CLEAN THE BUBBLER AND REINSTALL IT

Suitable for all processed surfaces: Clean the coating surface with neutral soapy water, and then thoroughly dry the entire surface with a clean soft cloth. Many cleaning agents, such as ammonia, detergent, toilet soap, etc., can cause damage to the surface of the coating. Remember to use them. Abrasive cleaning tools or cleaning agents should not be applied to faucets and their accessories

Product Warranty Guide

RANGE

This warranty policy applies to all sink products sold by our company, including but not limited to stainless steel, ceramics, quartz, and composite material sinks.

WARRANTY PERIOD

The warranty period for the sink is within one month from the date of purchase. During the warranty period, we will repair or replace any issues caused by manufacturing defects, and the cost will be borne by our company.

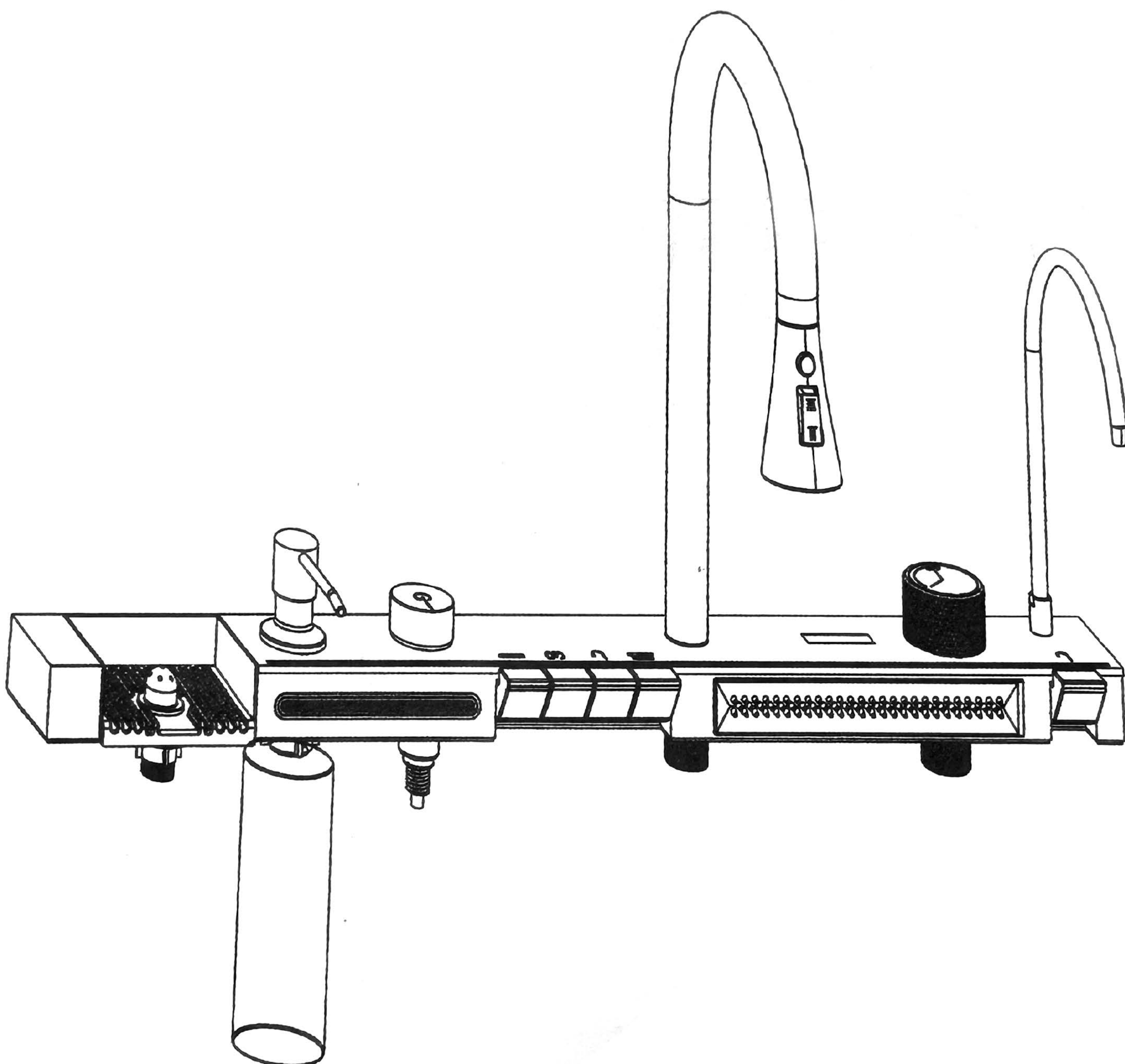

Product Warranty Guide

WARRANTY CONTENT

Manufacturing defects: If the sink encounters problems due to manufacturing defects under normal usage conditions, we will provide free repair or replacement services.

Material and process issues: For sink problems caused by material or process defects, we will be responsible for repairing or replacing them, and bear the related costs.

Leakage issue: If a leakage issue is found during the warranty period, we will provide free repair services, including repairing vulnerabilities or replacing affected components.

Non human damage: For non-human damage issues such as cracks, deformation, or corrosion, we will provide free repair or replacement services.

The warranty does not include the following situations:

Human damage: including but not limited to damage caused by incorrect installation, improper use, accidental collision or abuse.

Normal wear and tear: Slight wear and tear during normal use of the sink, such as scratches or surface discoloration.

Unauthorized repairs: If the sink is repaired by unauthorized individuals or companies, it will void the warranty.

WARRANTY PROCESS

Contact information: If you need to apply for warranty services, please contact us through our customer service center or official website.

Provide evidence: Provide evidence such as purchase vouchers or warranty cards to verify warranty eligibility.

Evaluation and Handling: Our professional team will evaluate the issue and determine if it meets the warranty conditions, and then provide corresponding repair or replacement services.

We are committed to providing customers with high-quality products and services, and we hope that you can enjoy a long-term comfortable experience when using our sinks. If you have any questions or need further assistance, please feel free to contact us at any time.