

# Assembly Instruction

Description : CORNER TABLE

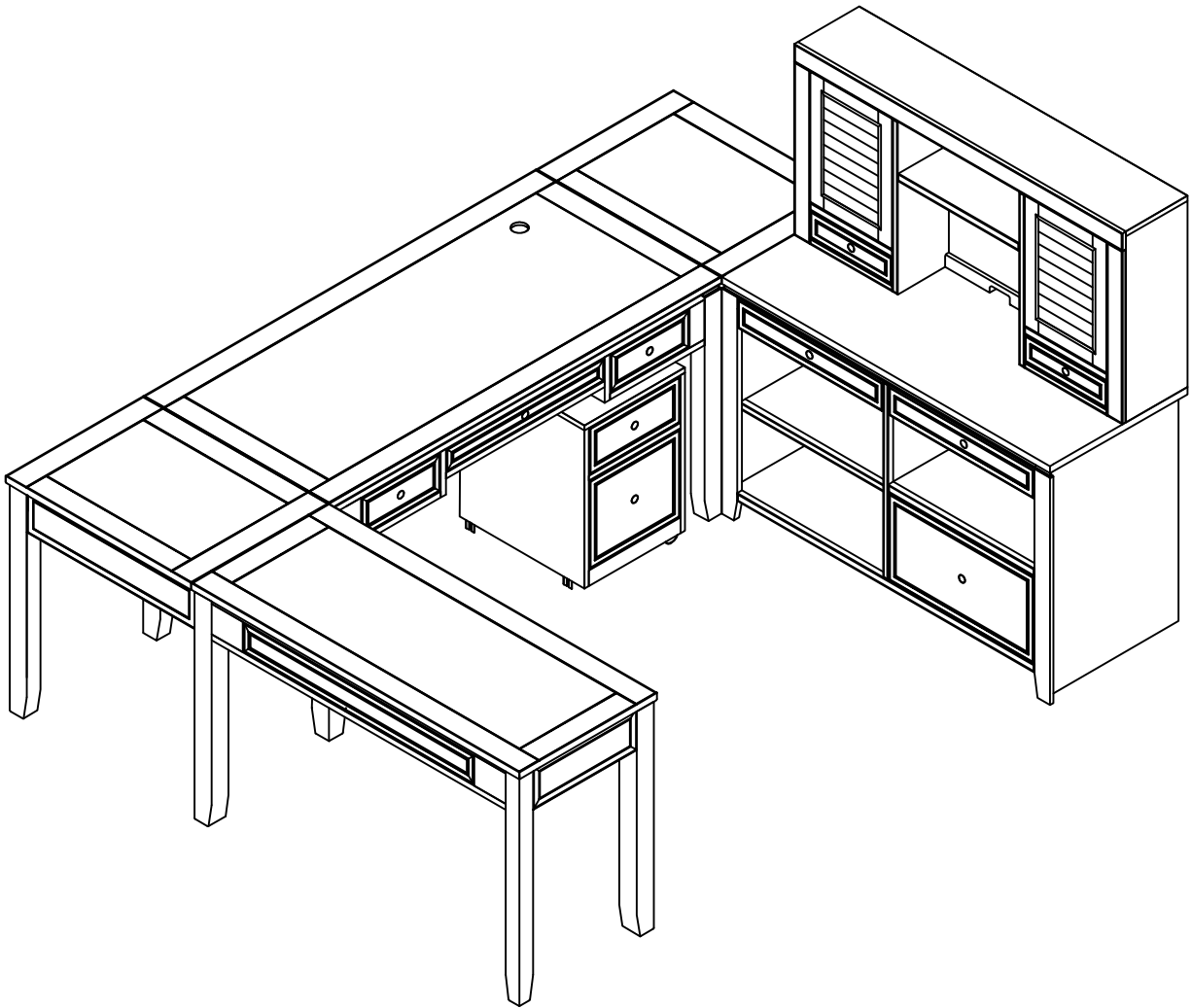









---



# Assembly Instruction

Description : CORNER TABLE

## HARDWARE LIST

No	Description	Sketch	Q'TY
A	Allen wrench 5mm		1PC
B	Bolt Ø 5/16"x2"		2PCS
C	Lock washer Ø5/16"x12mm		2PCS
D	Flat washer Ø5/16"x19mm		2PCS
E	Allen wrench 4mm		1PC
F	Bolt Ø 1/4"x1-1/2"		5PCS
G	Bolt Ø 1/4"x3/4"		8PCS
H	Lock washer Ø1/4"x12mm		13PCS
I	Flat washer Ø1/4"x19mm		13PCS
J	Long metal bracket		1PC
K	Short metal bracket		1PC

## PARTS LIST

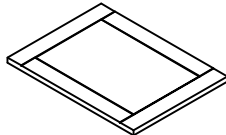
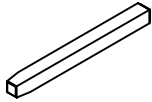
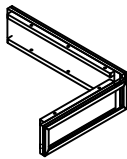
TABLE TOP (1PC)	LEG (1PC)
① 	② 
CORNER TABLE (1PC)	
	

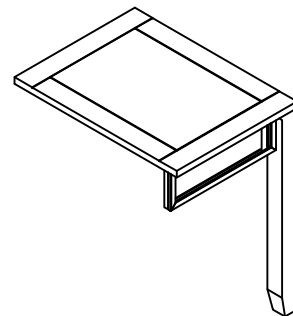

Hardware and leg pack is here

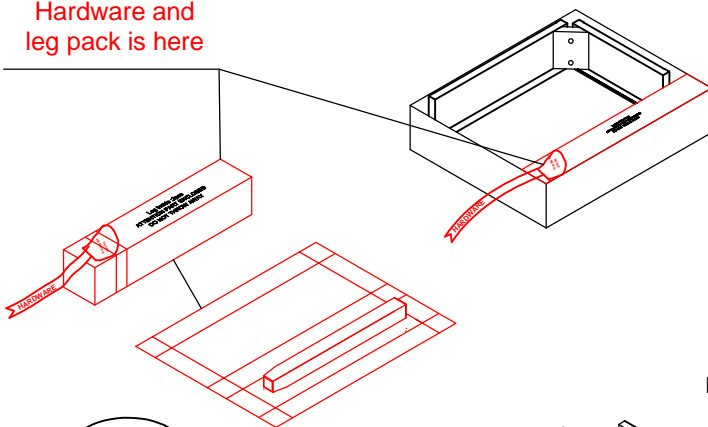

STEP 1

To set up a left corner table, please match the "L" label on the apron to the "L" label found underneath the corner table's top. to set up a right corner table, please match the "R" label on the apron to the "R" label found underneath the corner table's top.

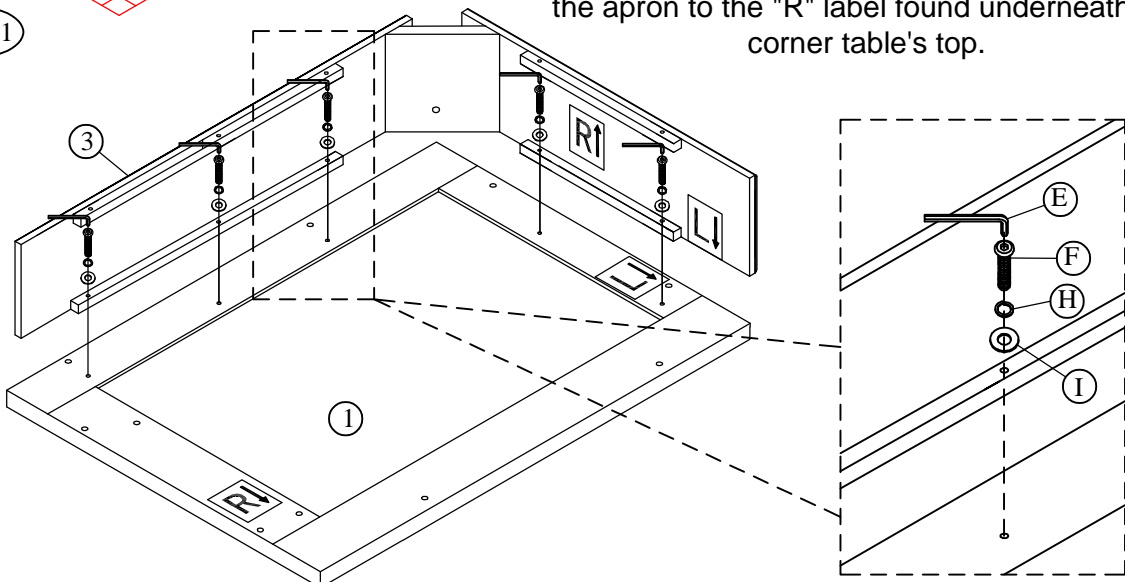

# Assembly Instruction

Description : CORNER TABLE

STEP 2

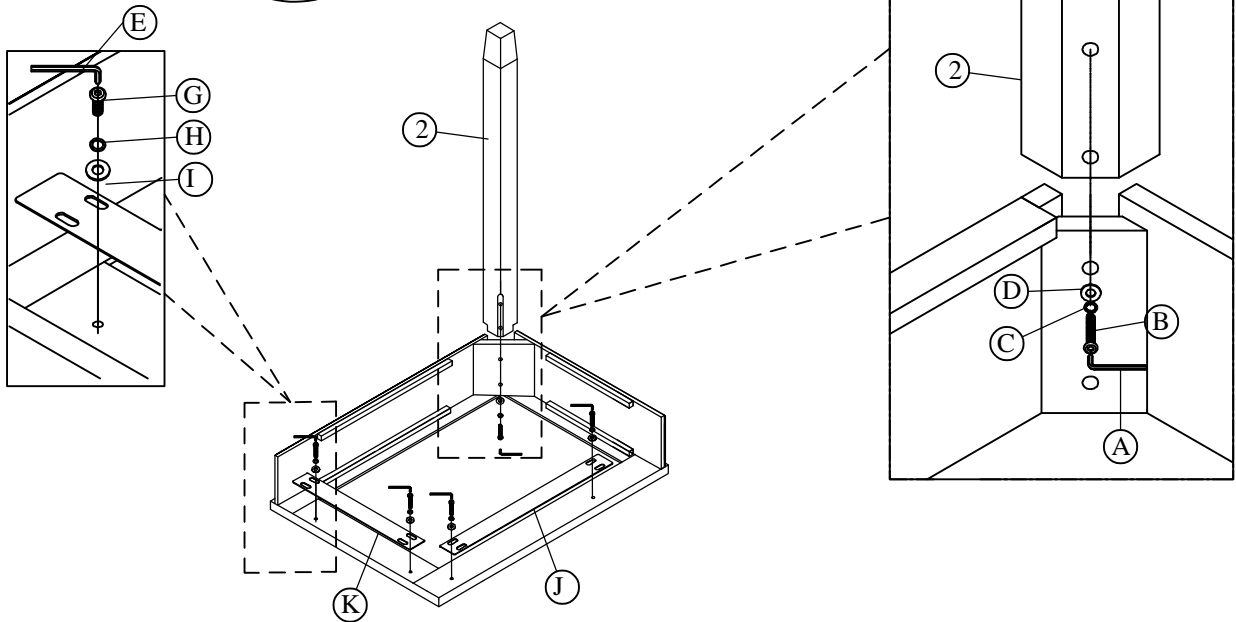

STEP 3

