

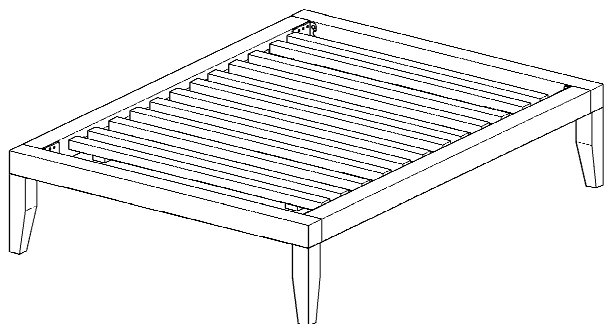





Before you start, here is some helpful advice:

1. We suggest you spend a short time reading through this leaflet and then follow the simple step by step instructions.
2. Owing to the size and weight of the nightstand, we recommend that it is assembled by two adults, on a carpeted or padded area, in the room that it is intended for. Approx assembly time: 20 minutes.
3. Please do not use any tools other than those provided or recommended in these instructions.
4. Please do not throw away any of the packaging or the instruction until you have checked all the components and hardware and the furniture is fully assembled.
5. Assemble all components loosely until advised to tighten. Depending on use, it may be necessary to tighten the components from time to time, so please save the tools that has been provided.
6. Please keep all small pieces out of reach of children.



Hardware:

A		JCBB BOLT M8 x 20	8 PCS
B		SPRING WASHER M5	8 PCS
C		FLAT WASHER M5	8 PCS
D		WOOD SCREW M4 X 32mm	6 PCS
E		ALLEN KEY M5	1 PC

Component :

1 -	HEADBOARD	x 1
2 -	FOOTBOARD	x 1
3 -	SIDERAIL	x 2
4 -	BED SLAT	x 13

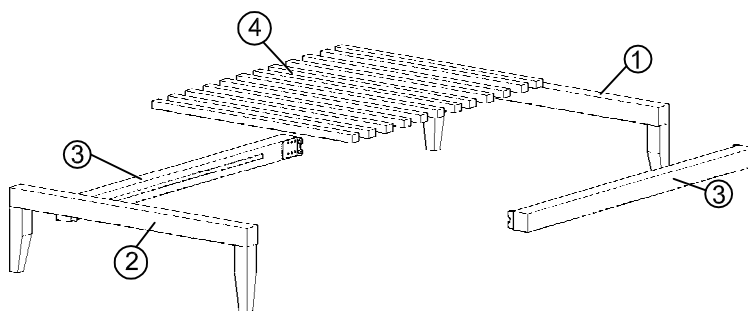

STEP 1:
 1. Attach the Headboard (1) and Footboard (2) into the Siderail(3) as per diagram shown. Place JCBB bolt 20MM(A), Spring washer(B), Flat washer(C) and tighten by using M5 Allen Key(E).

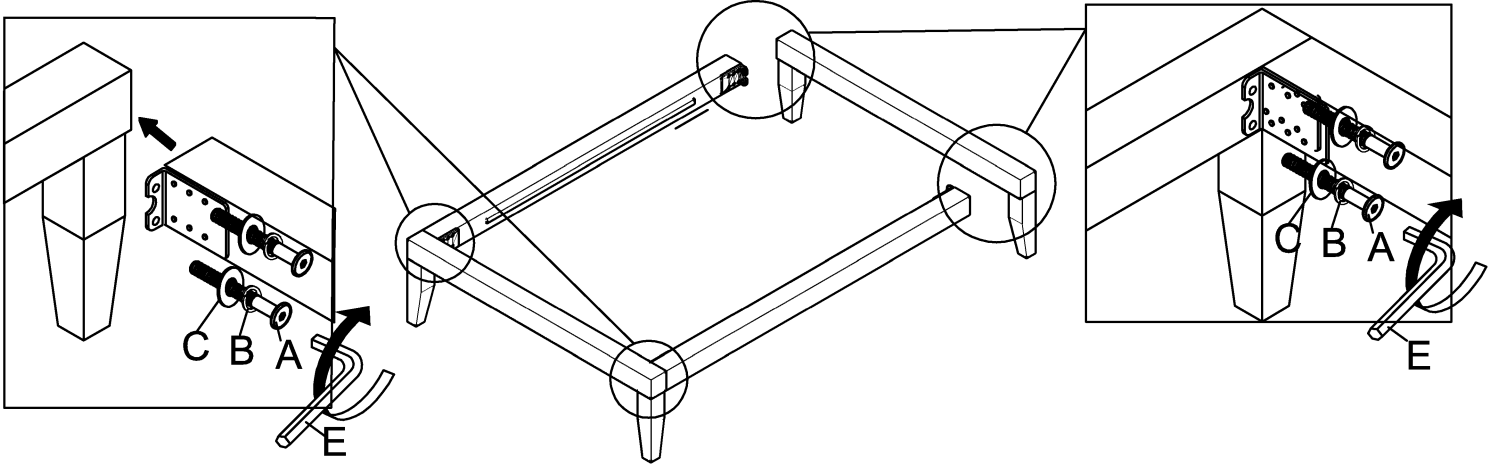

Ax8	Bx8	Cx8	Ex1

Hardware & Tool required

STEP 2:
 Attach Slat (7) into bed by inserting CSK screw (F) into the predrilled holes on the Slat (7) . Tighten with Screwdriver (Not provided) .

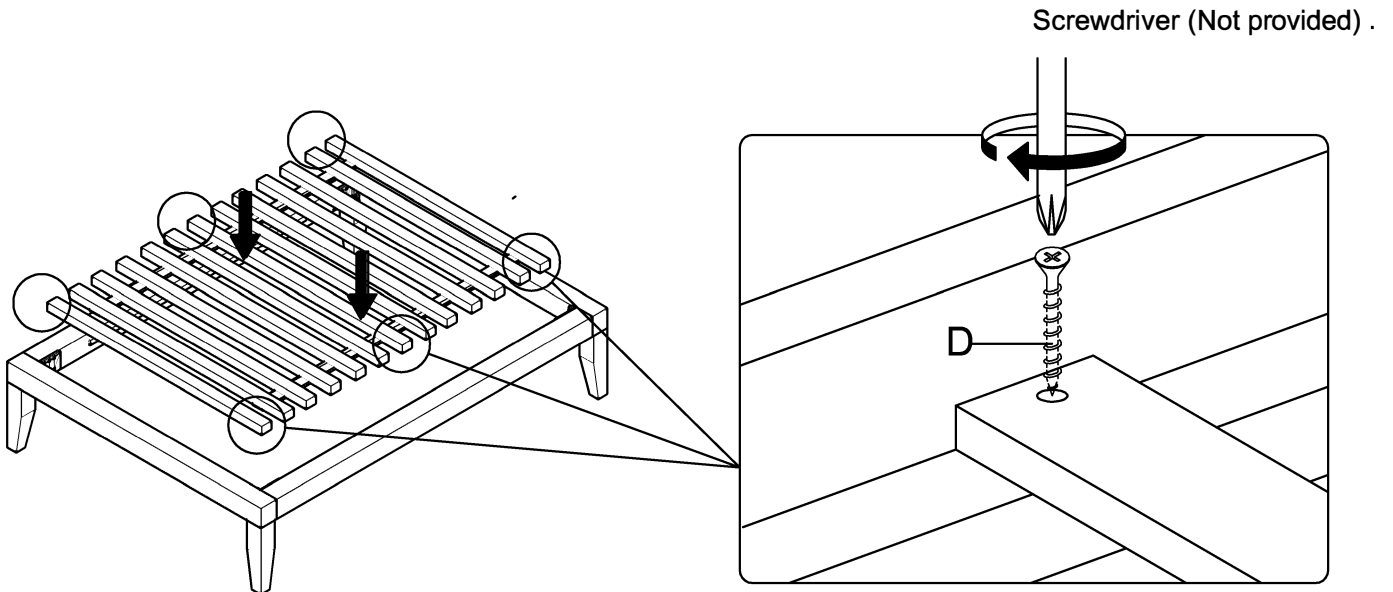

Dx6



Hardware & Tool required

Before you start, here is some helpful advice:

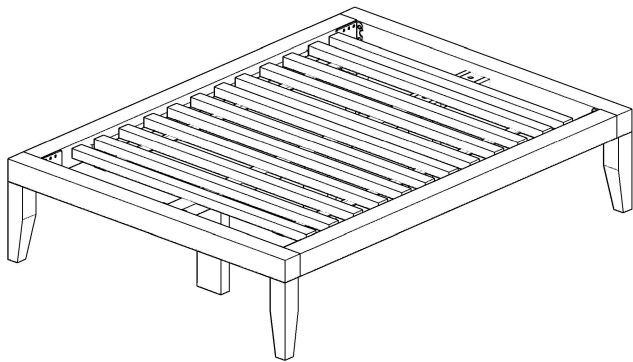
1. We suggest you spend a short time reading through this leaflet and then follow the simple step by step instructions.
2. Owing to the size and weight of the nightstand, we recommend that it is assembled by two adults, on a carpeted or padded area, in the room that it is intended for. Approx assembly time: 20 minutes.
3. Please do not use any tools other than those provided or recommended in these instructions.
4. Please do not throw away any of the packaging or the instruction until you have checked all the components and hardware and the furniture is fully assembled.
5. Assemble all components loosely until advised to tighten. Depending on use, it may be necessary to tighten the components from time to time, so please save the tools that has been provided.
6. Please keep all small pieces out of reach of children.



Hardware:

A		JCBB BOLT M8 x 20	8 PCS
B		JCBC BOLT M6 x 40	4 PCS
C		JCBC BOLT M6 x 50	5 PCS
D		SPRING WASHER 5/16	8 PCS
E		FLAT WASHER 2MM	8 PCS
F		CSK SCREW M4 X 32mm	6 PCS
G		M4 ALLEN KEY LONG WITH BALL	1 PC
H		M5 ALLEN KEY	1 PC
I		ADJUSTER	3 PCS

Component :

1 -	HEADBOARD	x 1
2 -	FOOTBOARD	x 1
3 -	SIDERAIL	x 2
4 -	CENTER SUPPORT	x 1
5 -	SUPPORT LEG	x 3
6 -	SUPPORT BAR	x 2
7 -	BED SLAT	x 13

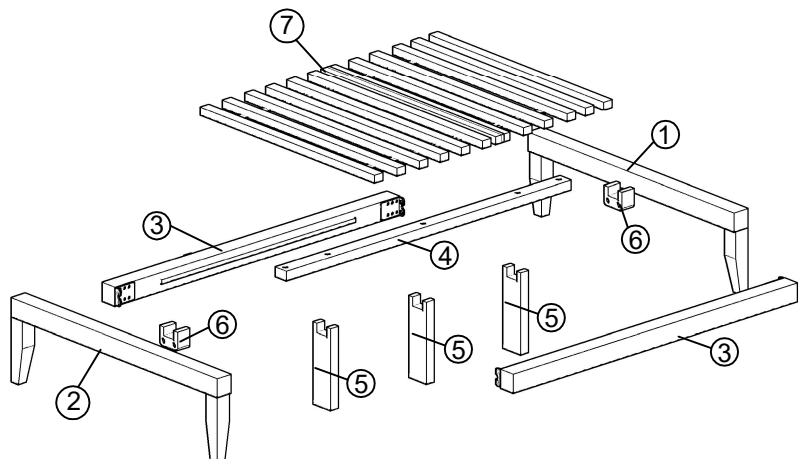

STEP 1:

1. Attach the Headboard (1) and Footboard (2) into the Siderail(3) as per diagram shown. Place JCBB bolt 20MM(A), Spring washer(D), Flat washer(E) and tighten by using M5 Allen Key(H).

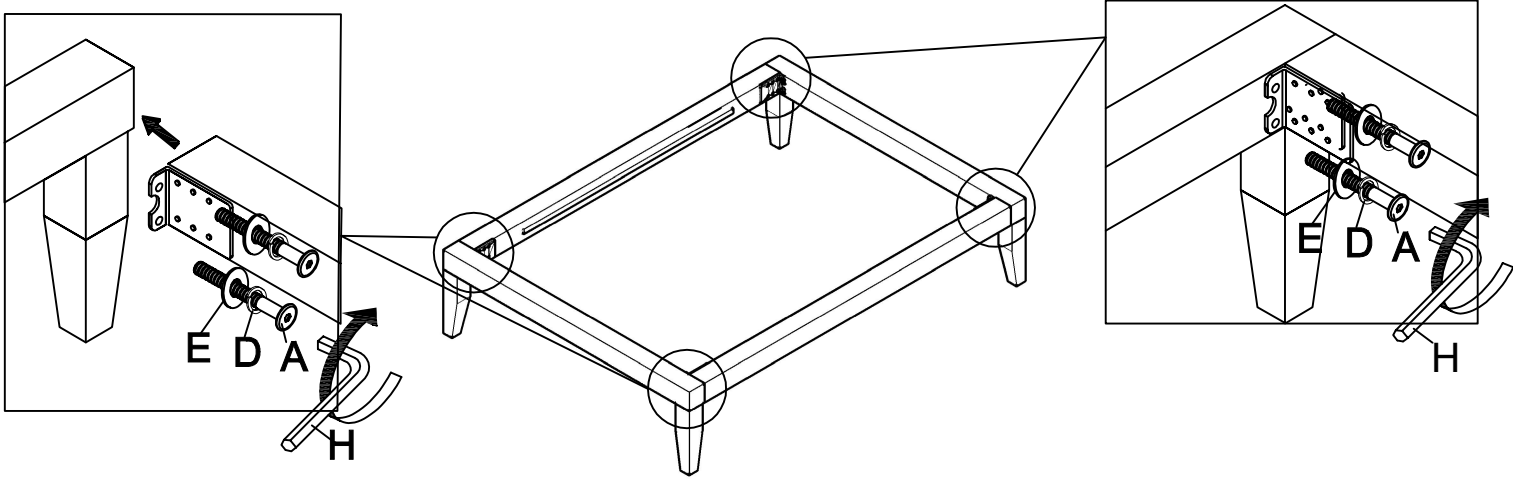

Ax8	Dx8	Hx1	Ex8

Hardware & Tool required

STEP 2:

1. Attach Support bar(6) into Headbord(1) and Footboard(2) then insert JCBC Bolt 40mm(B) and tighten by using M4 Allen Key(G)

2. Attach Centre Support(4) into Support bar(6) (assemble in step 1) then insert JCBC Bolt 50mm(C) and tighten by using M4 Allen Key(G) as per diagram.

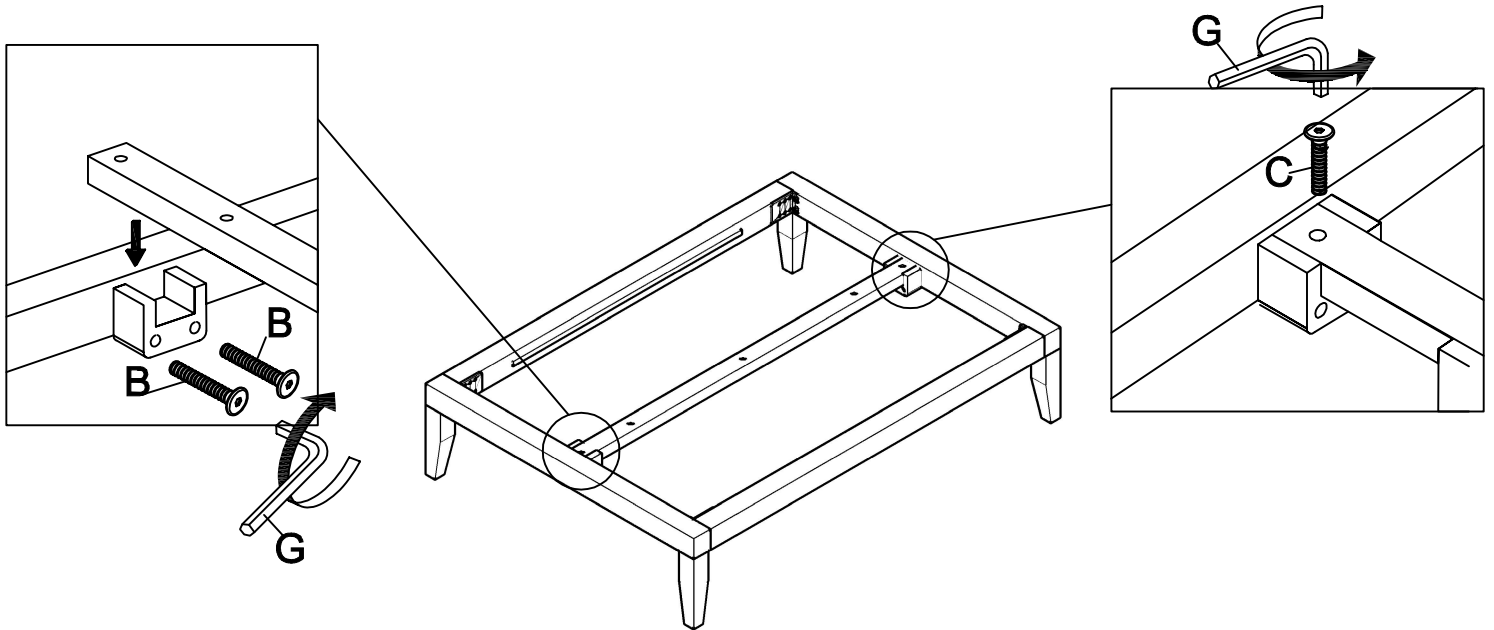





Bx4	Cx2	Gx1

Hardware & Tool required

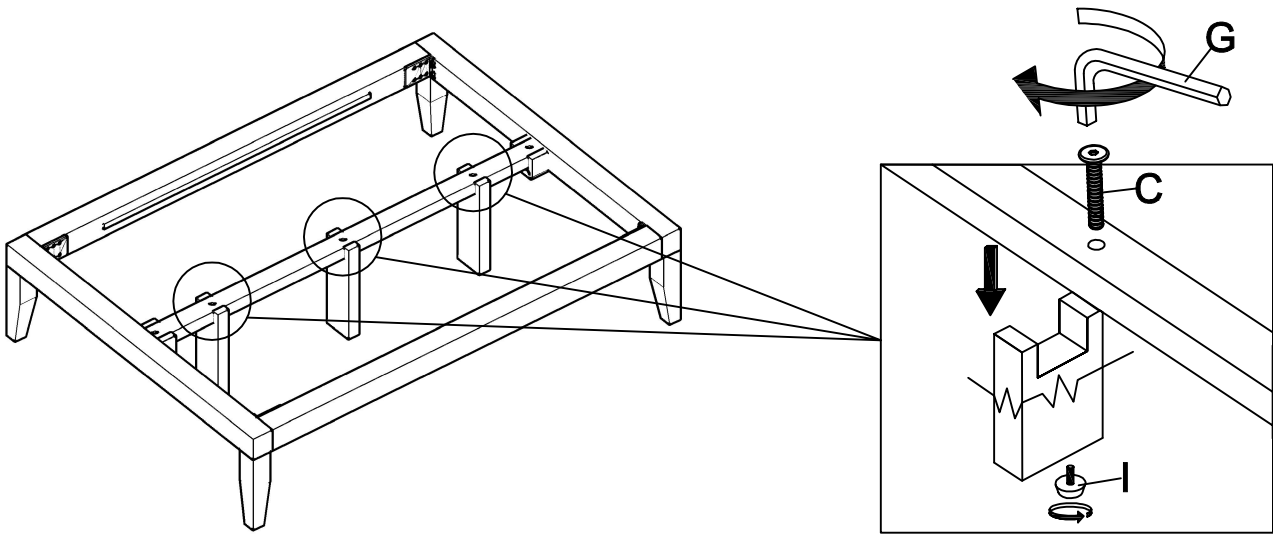
STEP 3:

1. Attach the Support leg(5) as shown in diagram. Place the JCBC bolt 50MM(D)) and tighten by using M4 Allen Key(G) After, place Adjuster (I) to bottom support leg(5) as diagram shown.



		
Cx3	Gx1	Ix3

Hardware & Tool required

STEP 4:

Attach Slat (7) into bed by inserting CSK screw (F) into the predrilled holes on the Slat (7) . Tighten with Screwdriver (Not provided) .

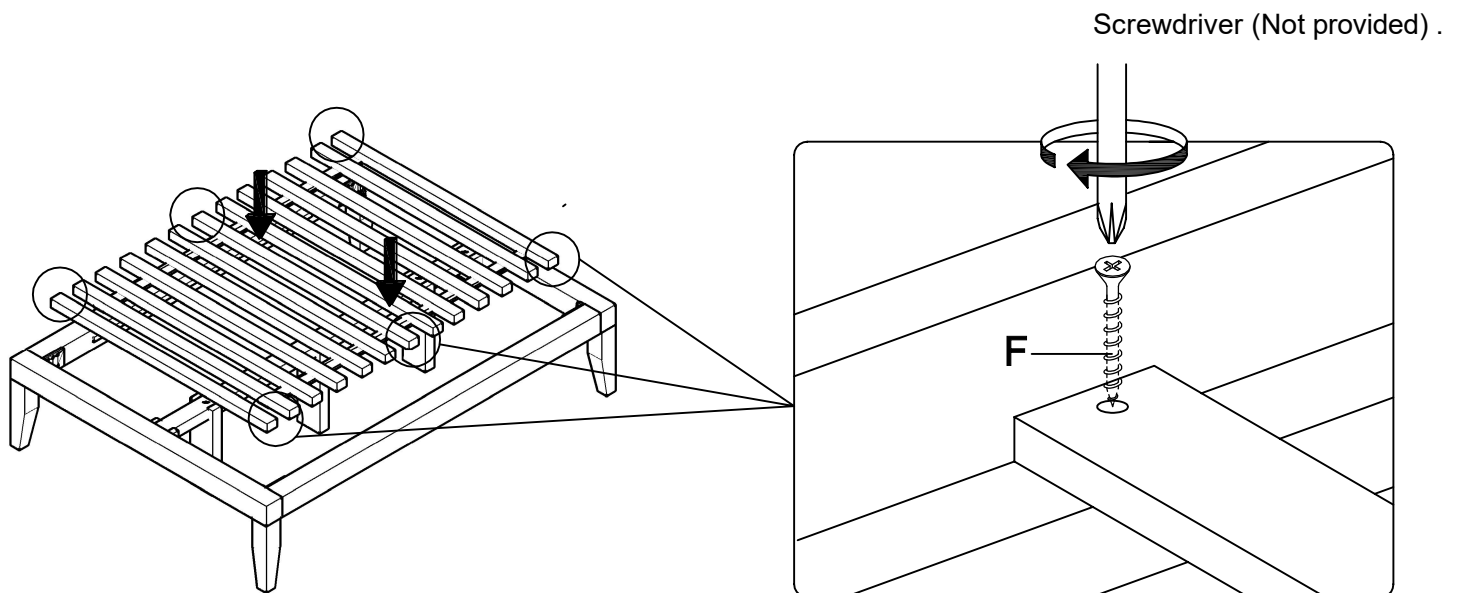

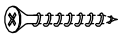
Fx6

Hardware & Tool required