

Console Table

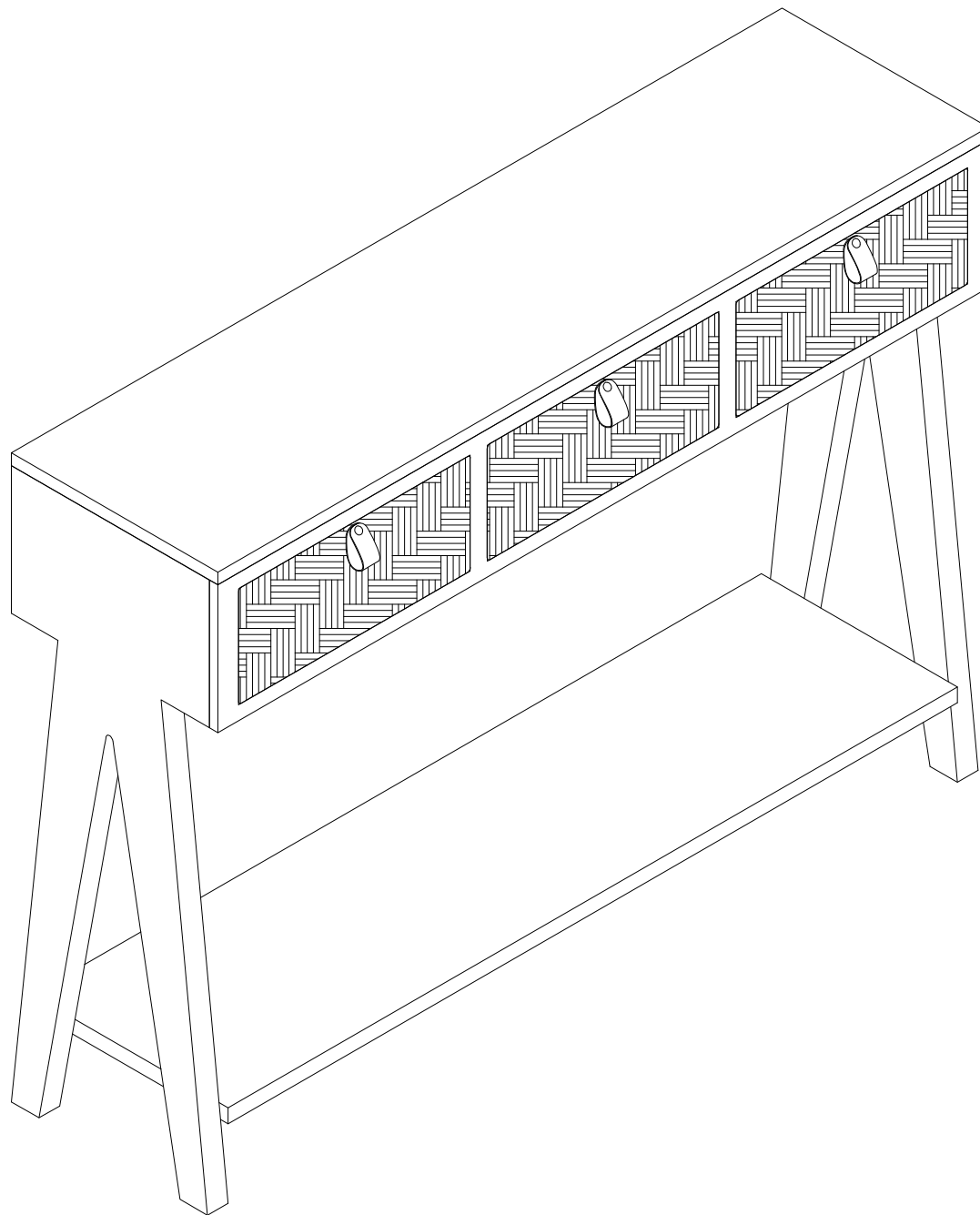

THIS INSTRUCTION BOOKLET CONTAINS IMPORTANT SAFETY INFORMATION. PLEASE READ AND KEEP FOR FUTURE REFERENCE.



WARNING

- Unit can tip over causing severe injury or death.
- Anchor unit to stud in wall (if instructed to)
- Do Not allow children to climb on unit.
- put heavy items on lower shelves or drawers.

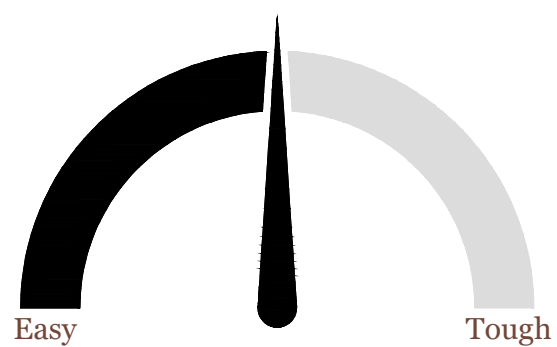

Assembly Difficulty Meter

HELPFUL HINTS

PEOPLE NEEDED FOR ASSEMBLY:2
ESTIMATED ASSEMBLY TIME:1 HOUR

- Open your item in the area you plan to keep it to avoid excessive heavy lifting.
- Identify,sort and count the parts before attempting assembly.
- Back panel must be used to make sure your unit is sturdy.
- Do NOT use harsh chemicals or abrasive cleaners on this item.
- Never push,pull,or drag your furniture.

BEFORE YOU START

- ✓ Read through each step carefully and follow the proper order
 - ✓ Separate and count all your parts and hardware
 - ✓ Give yourself enough room for the assembly process
 - ✓ Have the following tools:Flat Head Screwdriver,#2 Phillips Head Screwdriver and Hammer
 - ✓ Caution: IF using a power drill or power screwdriver for screwing,please be aware to slow down and stop when screw is tight.Failure to do so may result in stripping the screw.
-

BOARD IDENTIFICATION

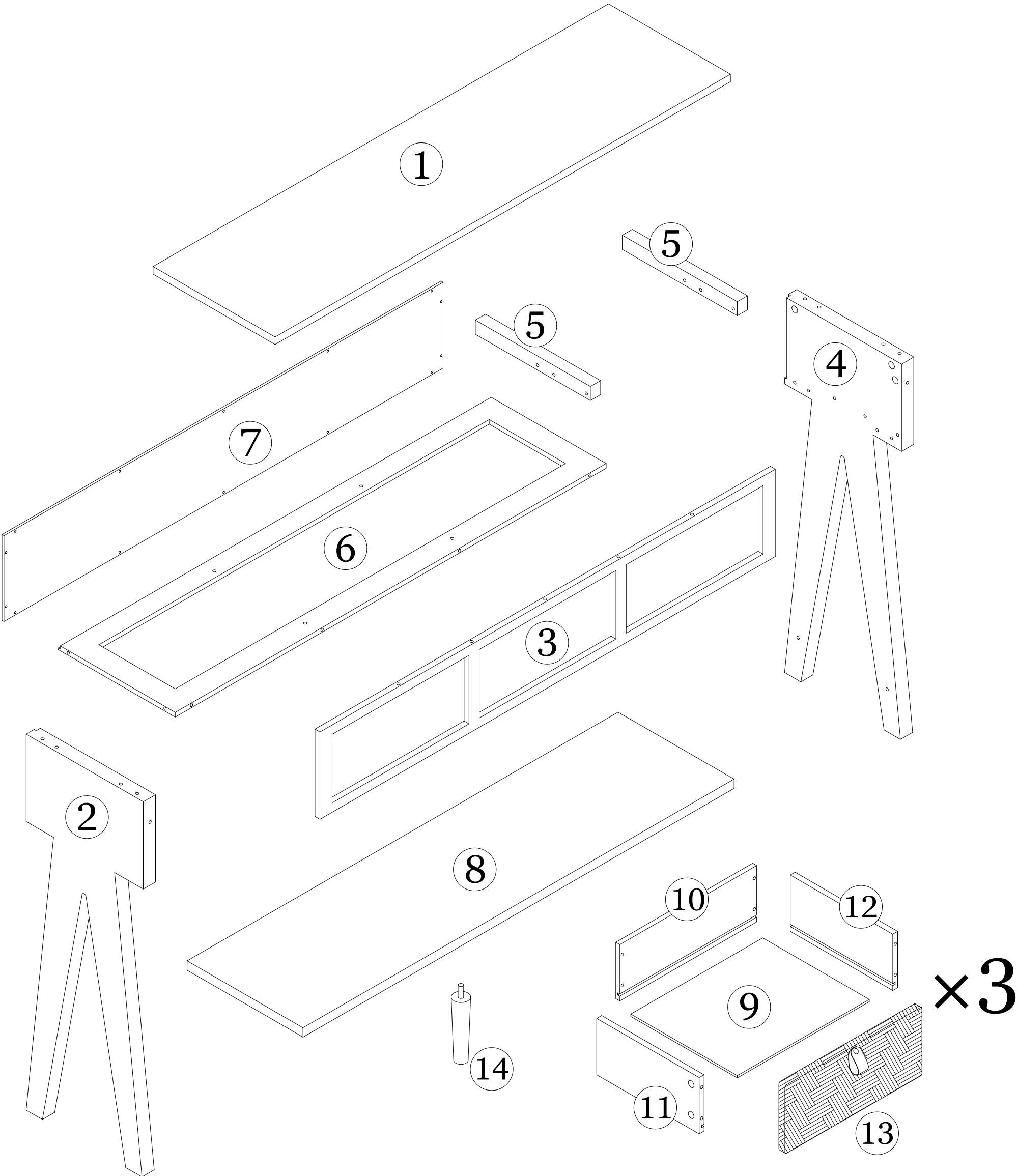

THE HARDWARES

A	×28+1(Spare)
	
Cam Bolt M6×25mm	

B	×28+1(Spare)
	
Cam Lock	

C	×10+1(Spare)
	
Wood Dowel φ6×30mm	

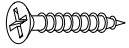
D	×8
	
Screw M4×16mm	

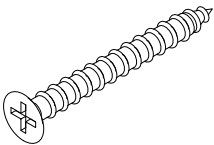
E	×4
	
Screw M4×25mm	

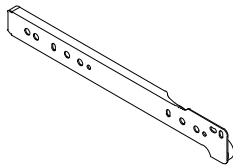
F	×3
	
Drawer Slide Kit	

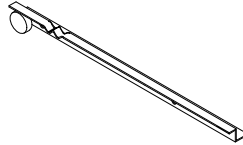
G	×3
	
Drawer Slide Kit	

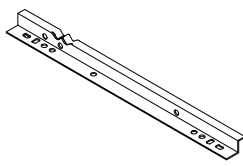
H	×3
	
Drawer Slide Kit	

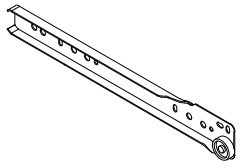
I	×3
	
Drawer Slide Kit	

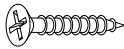
J	×30+2(Spare)
	
Screw M3.5×12mm	

K	×4
	
Bracket	

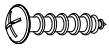
L	×14+1(Spare)
	
Screw M3×12mm	

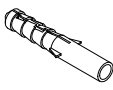
M	×2
	
Anchor M6×30mm	

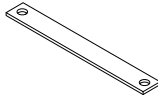
N	×2
	
Anti tipping strap	

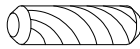
O	×3
	
Wood Dowel φ6×20mm	

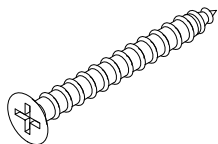
P	×2
	
Screw M4×35mm	

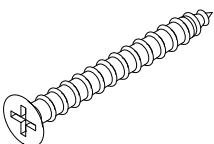
Q	×12+1(Spare)
	
Screw M3.5×30mm	

IMPORTANT :

1. Do not tighten bolts / screws completely until all bolts / screws are lined up and inserted into holes.
2. Do not over tighten screws and bolts to avoid stripping.
3. Please use hand tools to assemble this product. Do not use power tools.
4. Must need 2 people to assemble this product.

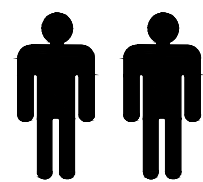

2 PERSONS

CAM LOCK FASTENING SYSTEM

This Cam Lock Fastening System will be used throughout the assembly process.

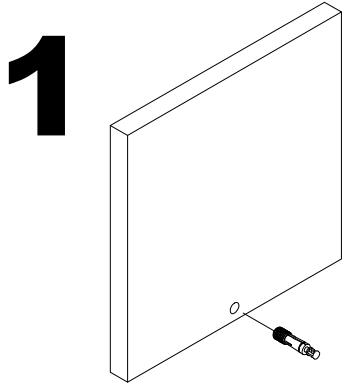

1
Press CAM BOLT into hole.

2

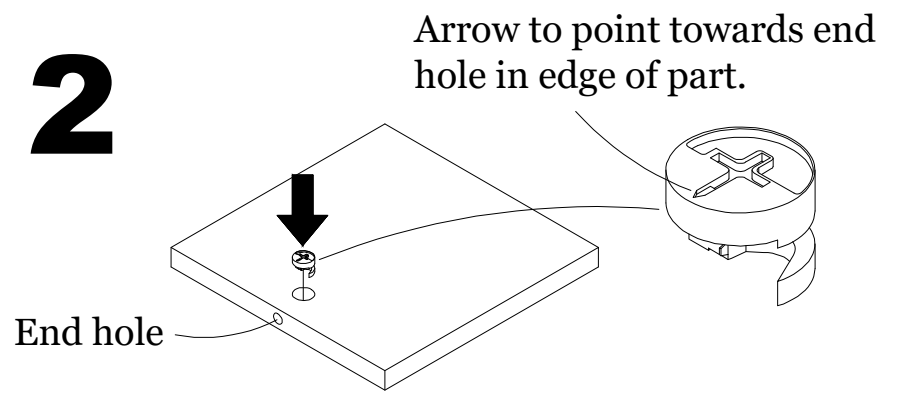

Press CAM LOCK into hole.

3

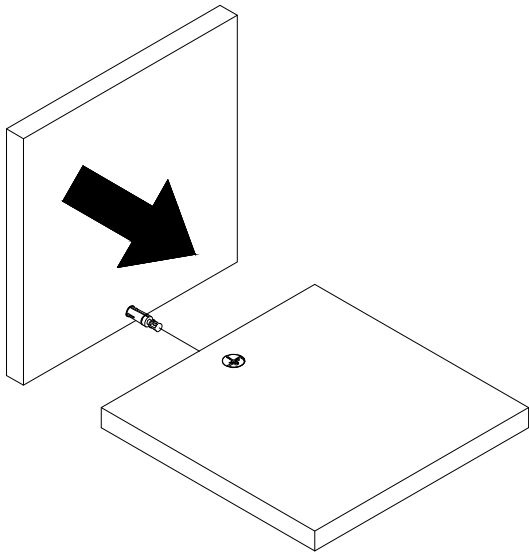

Press parts together so CAM BOLT inserts into edge hole.

4

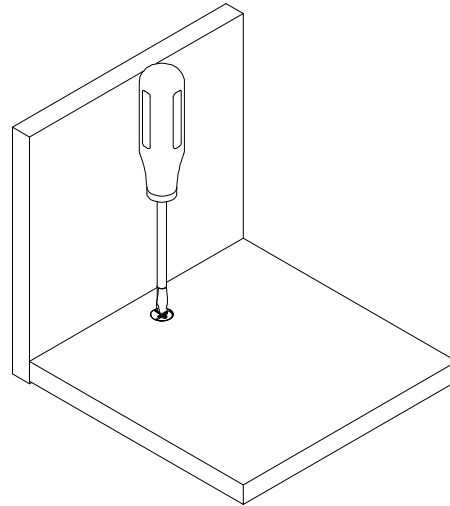

Using a screwdriver, turn the CAM LOCK clockwise to lock the CAM LOCK and CAM BOLT into their holes and fastening parts together.

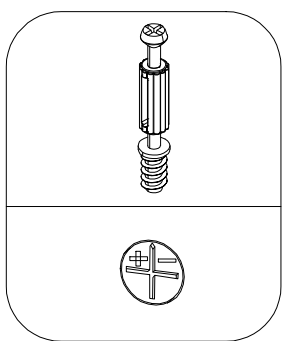

Notice: Proper orientation of CAM LOCK

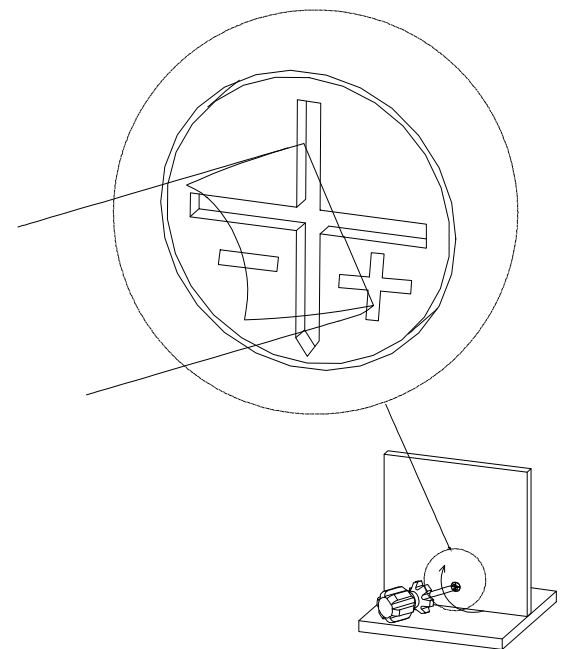
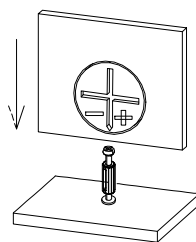
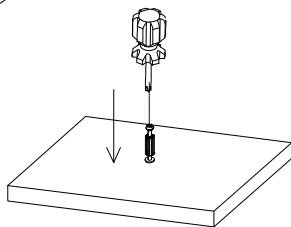
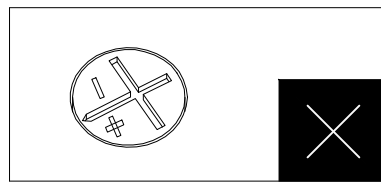
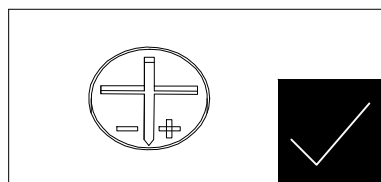

INSTALLATION STEPS

STEP 2

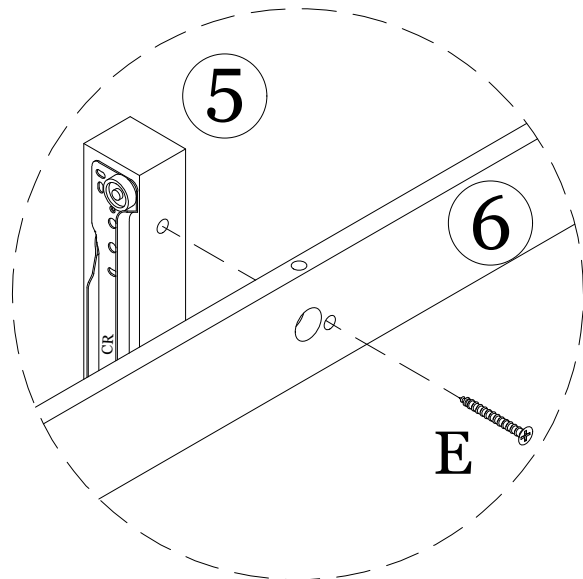
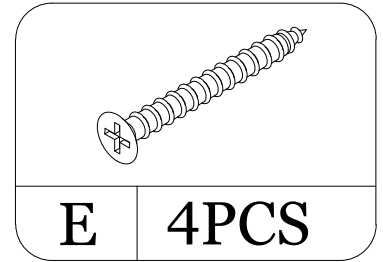

Installation in the direction of the prompts

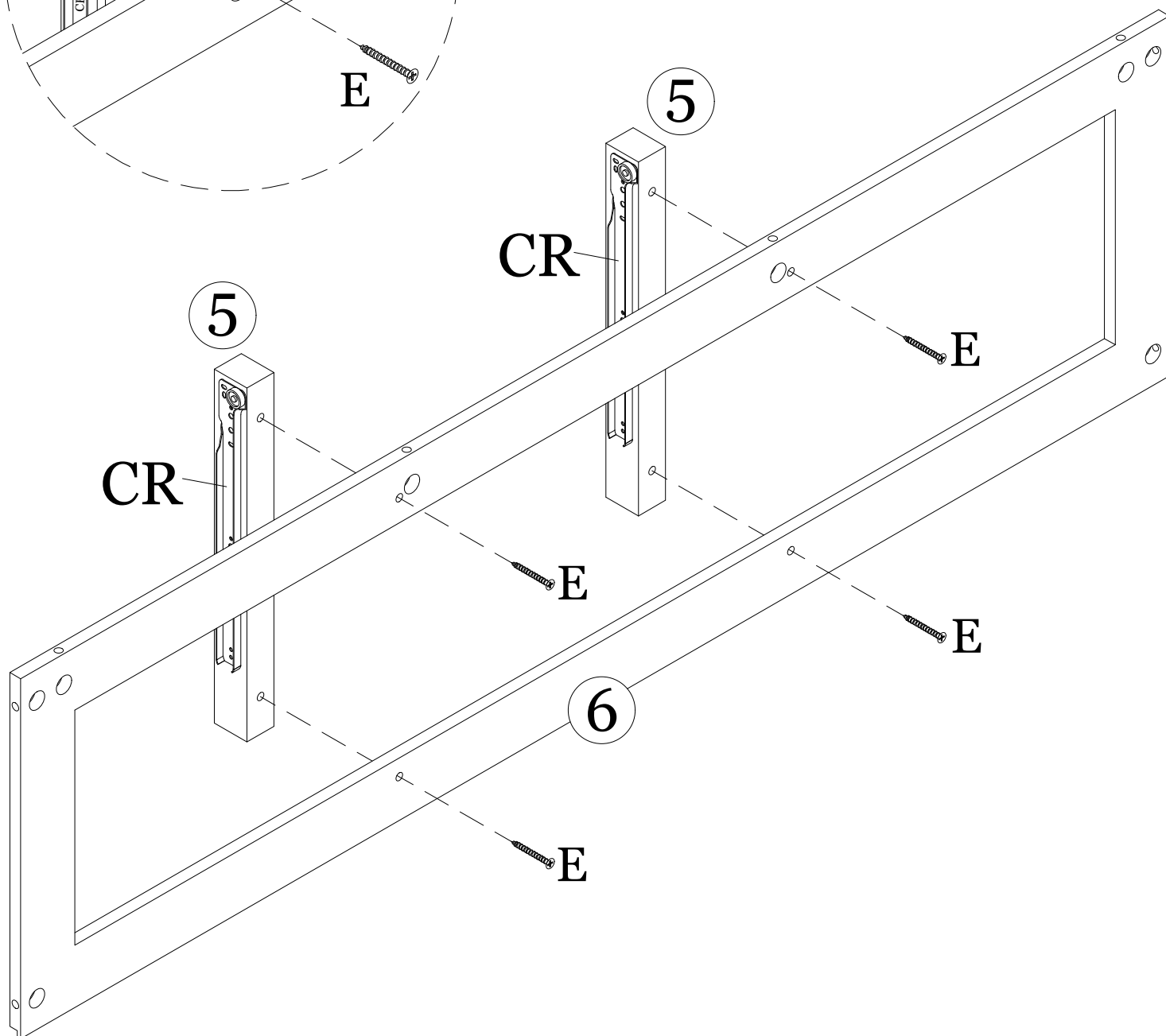

INSTALLATION STEPS

STEP 3

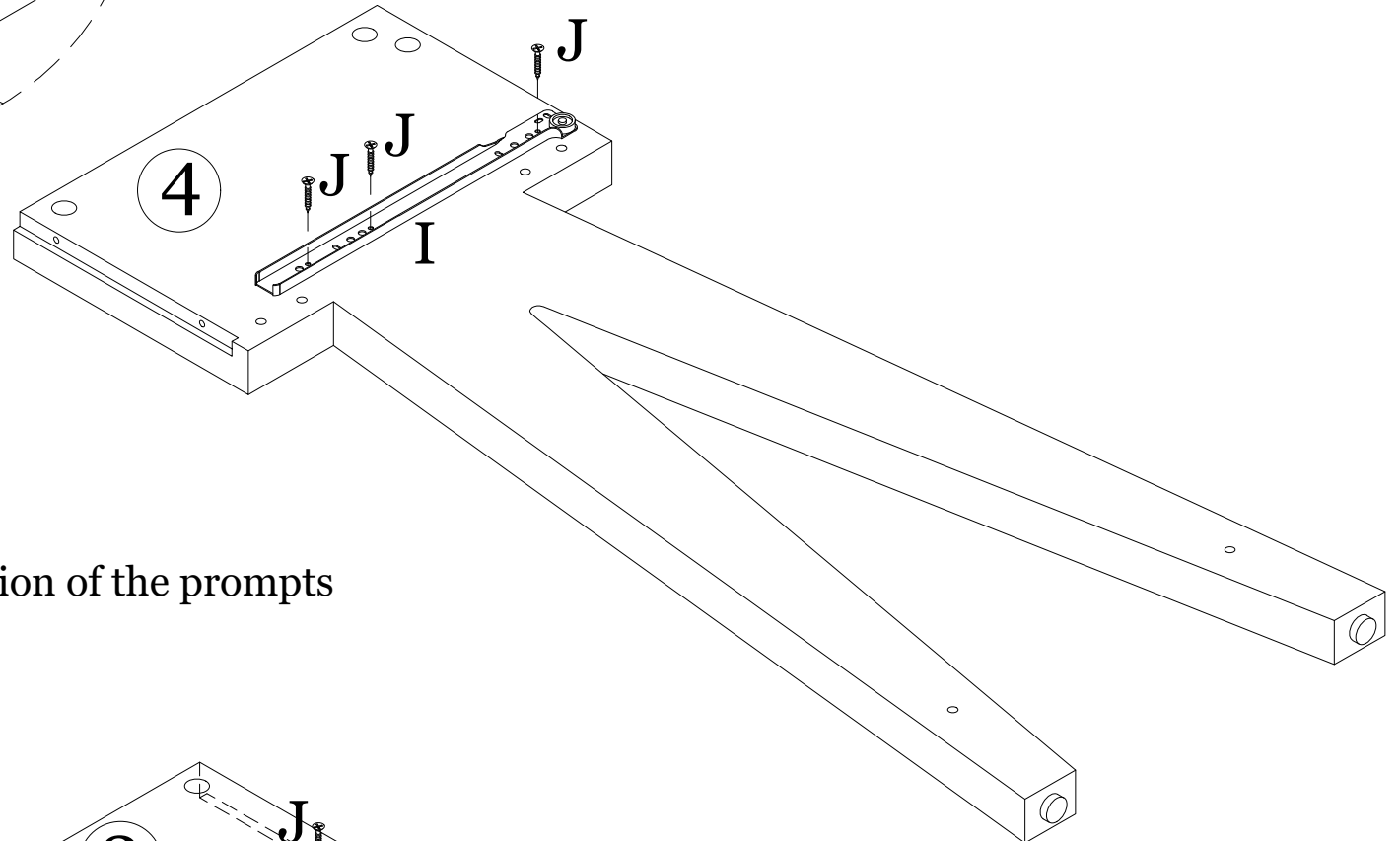
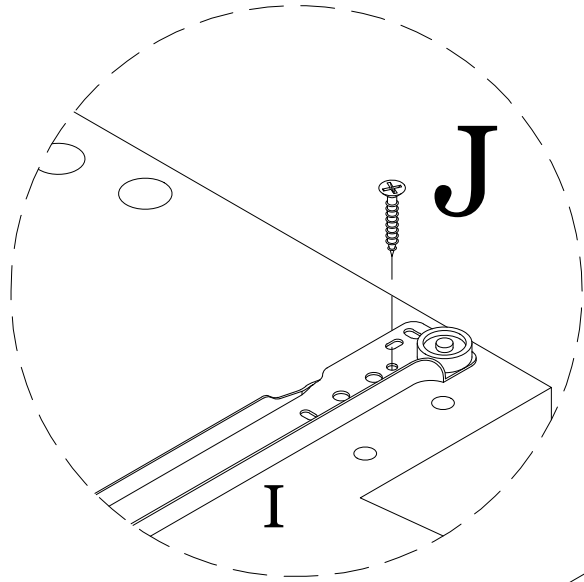
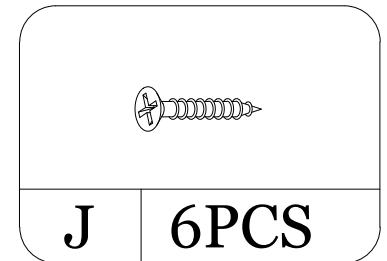
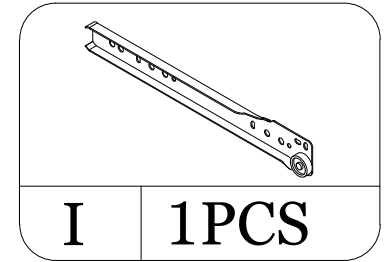
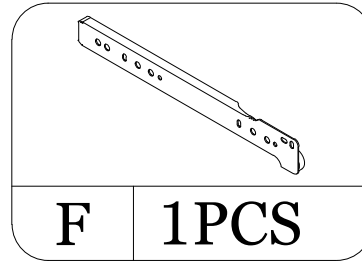

Installation in the direction of the prompts

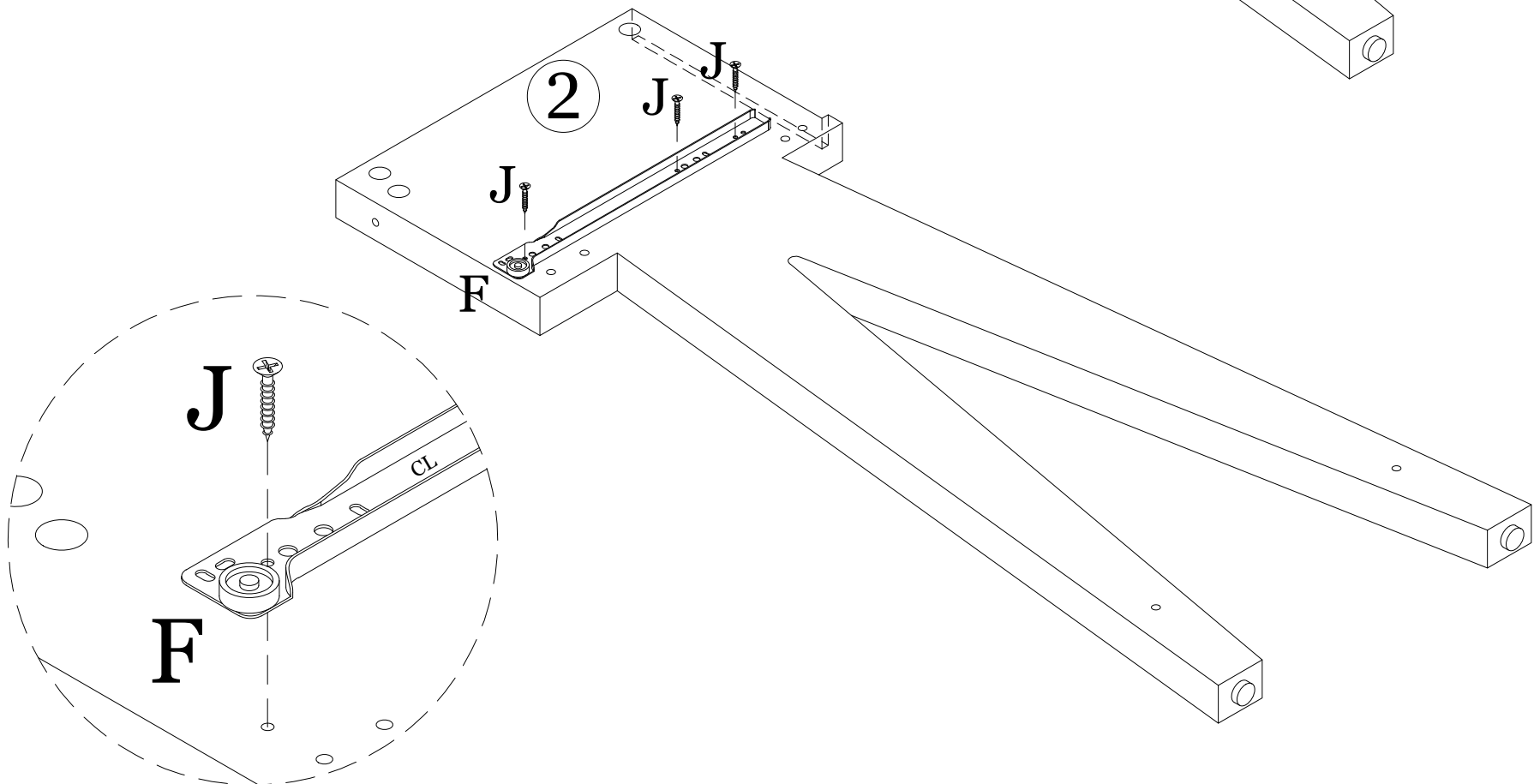

INSTALLATION STEPS

STEP 4

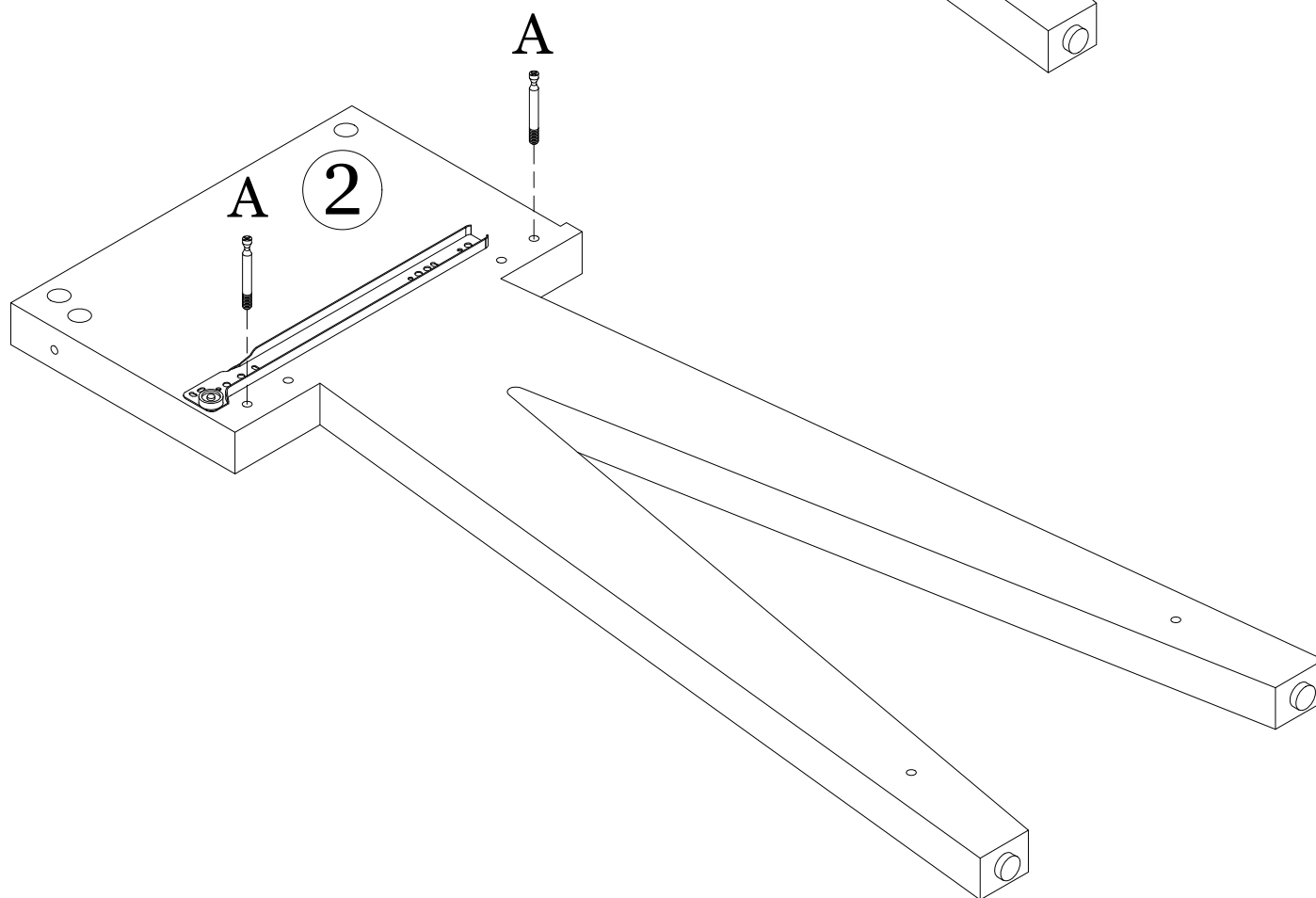
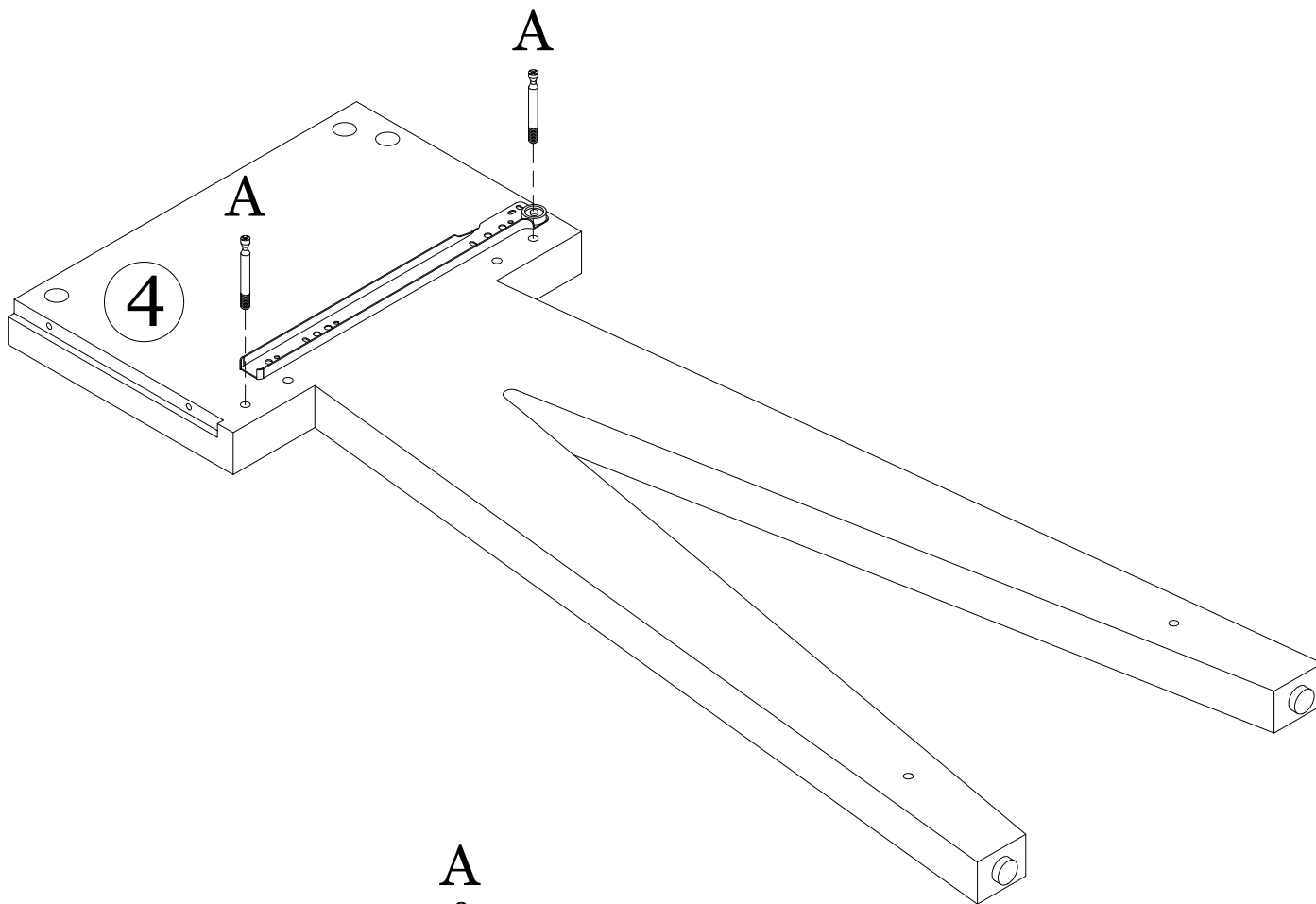
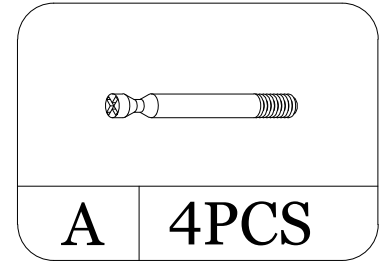

INSTALLATION STEPS

STEP 5

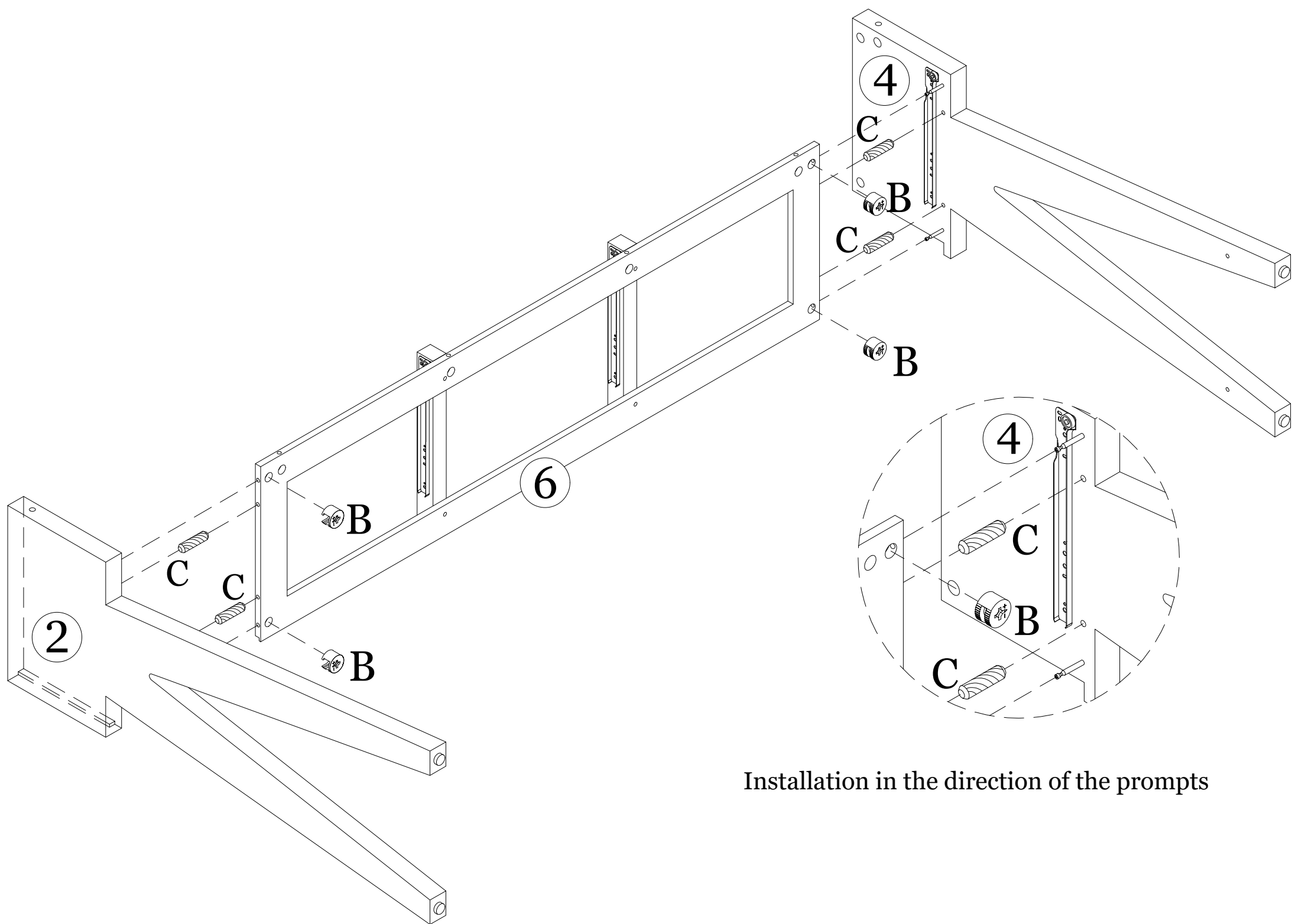
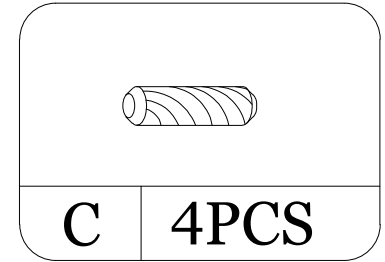
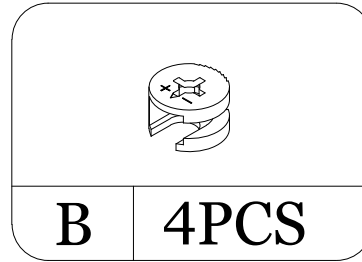

Installation in the direction of the prompts

INSTALLATION STEPS

STEP 6

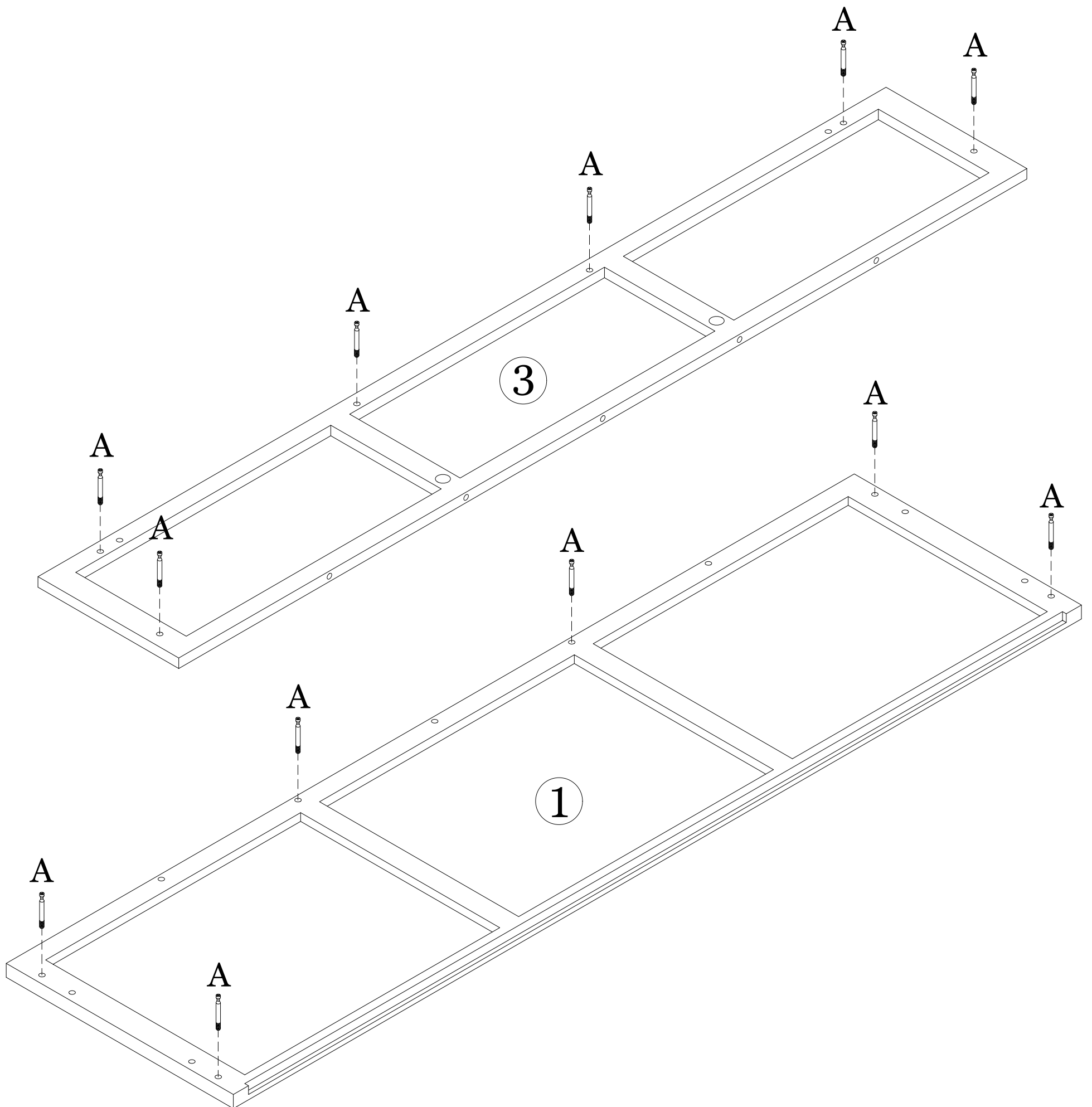
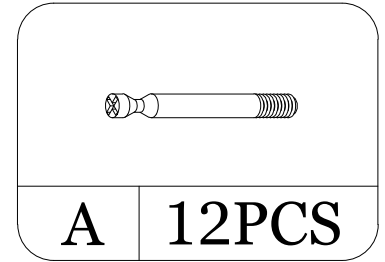

INSTALLATION STEPS

STEP 7

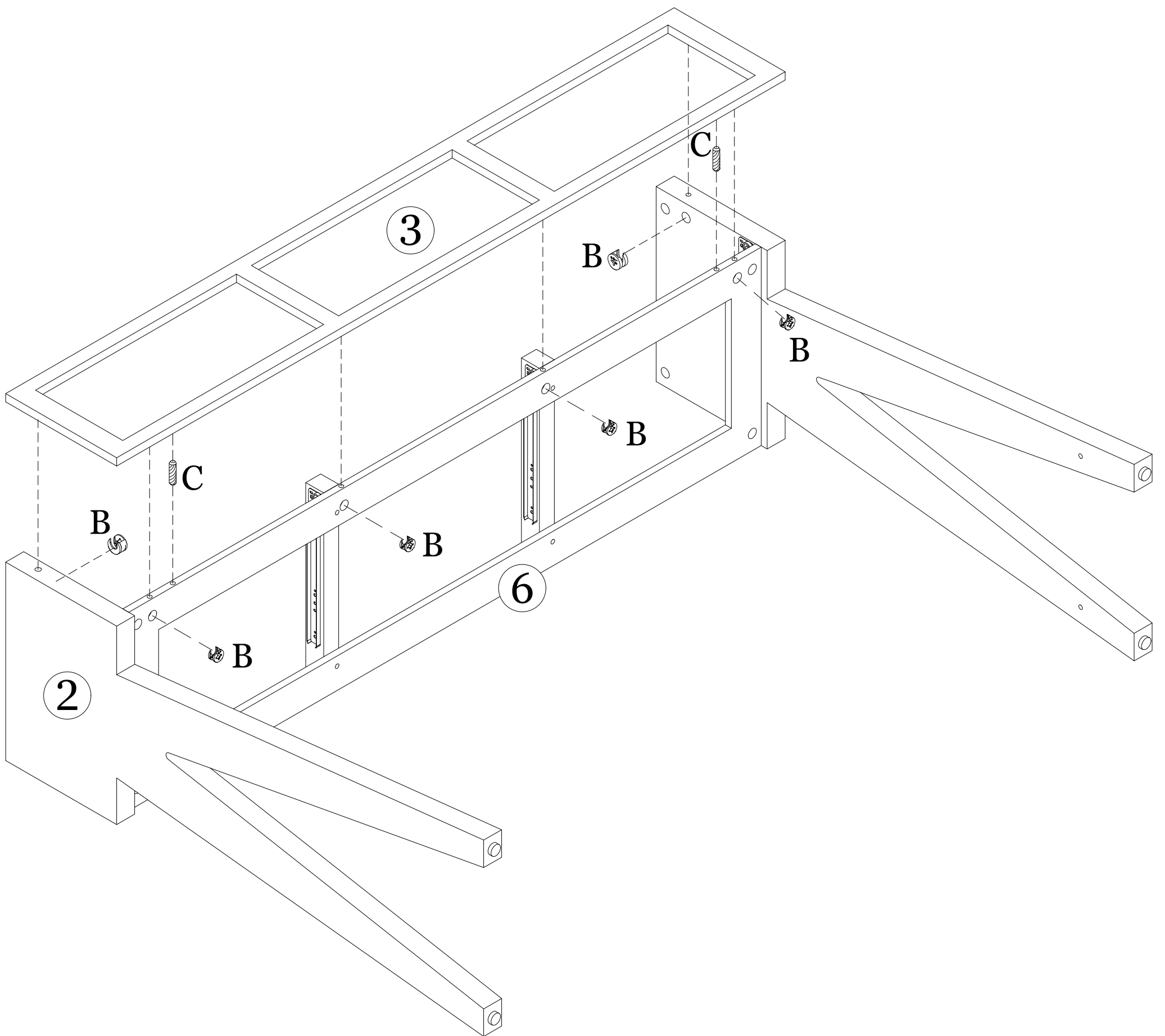
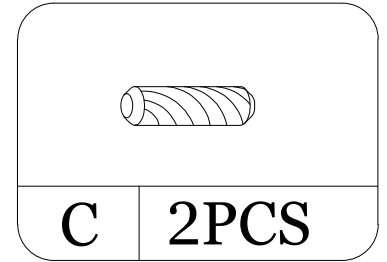
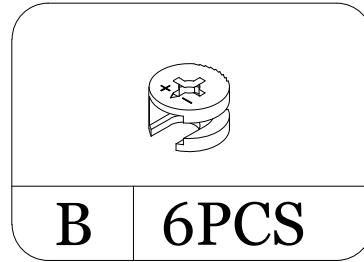

INSTALLATION STEPS

STEP 8

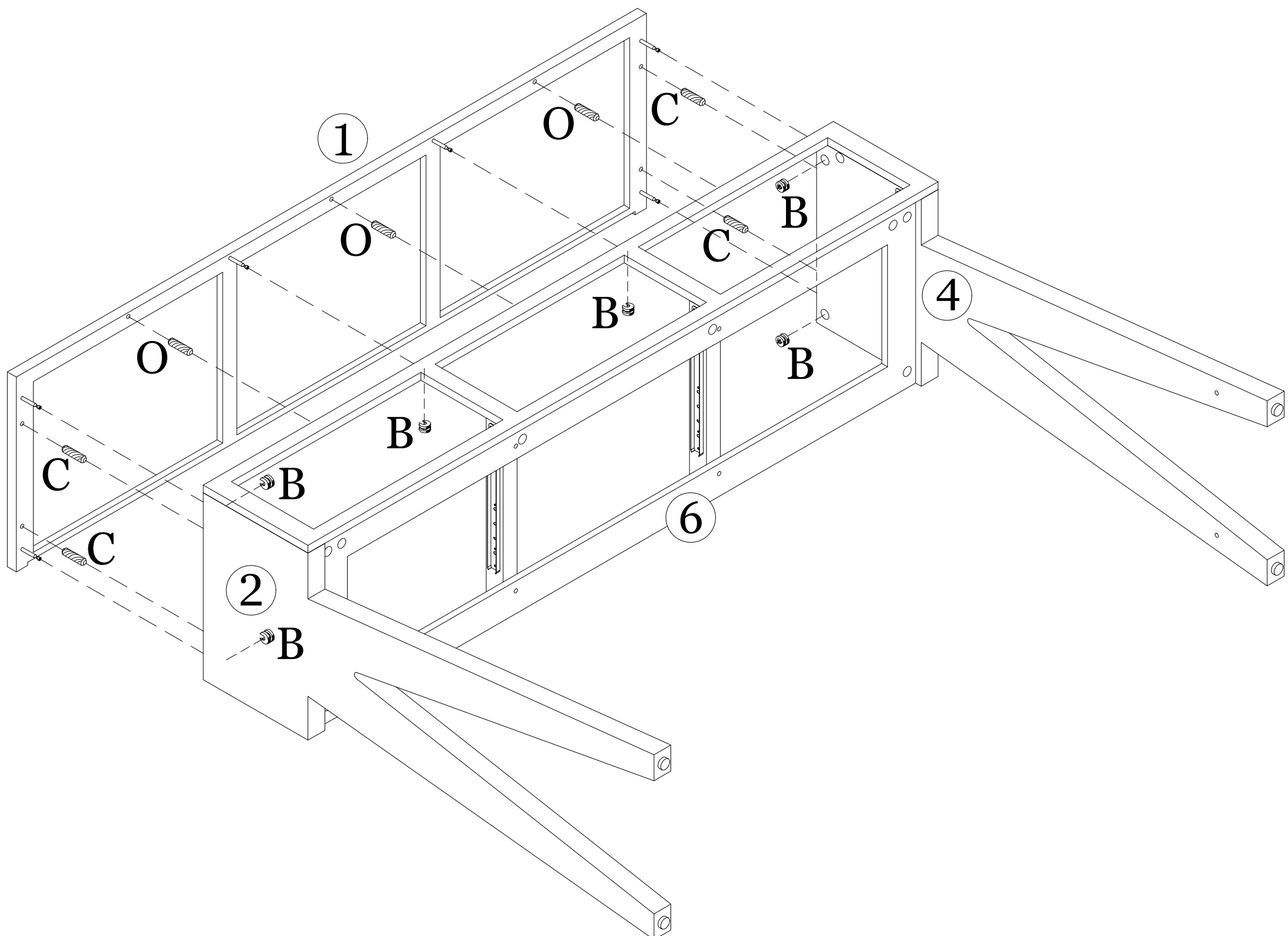
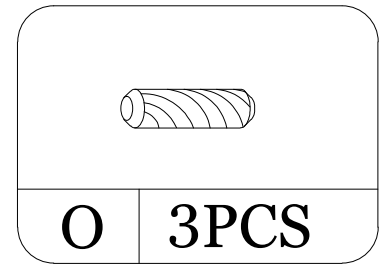
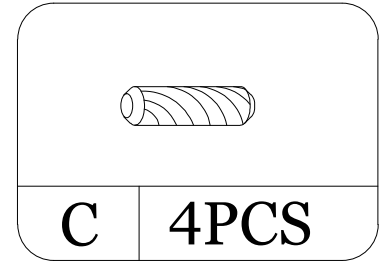
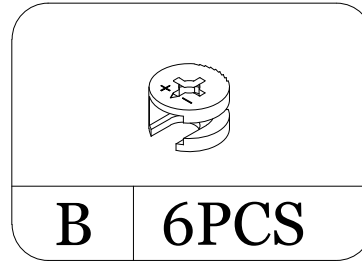

INSTALLATION STEPS

STEP 9

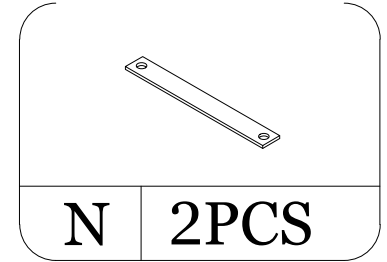
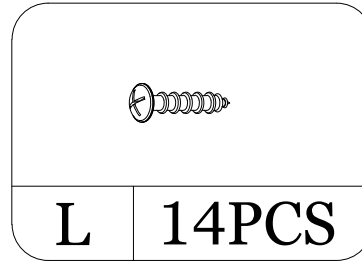

When step 8 is complete, turn the console table on its opposite side.

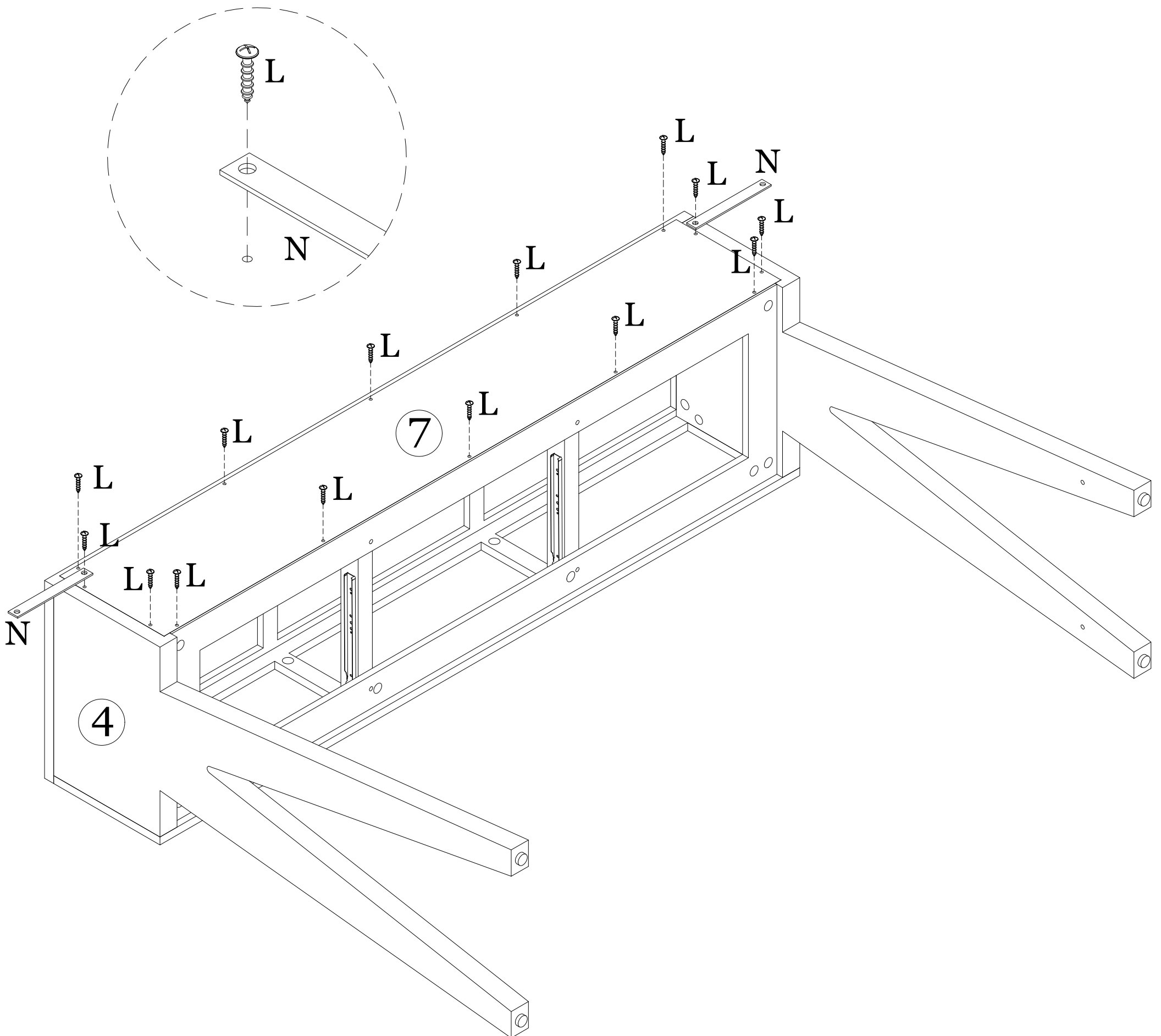

INSTALLATION STEPS

STEP 10

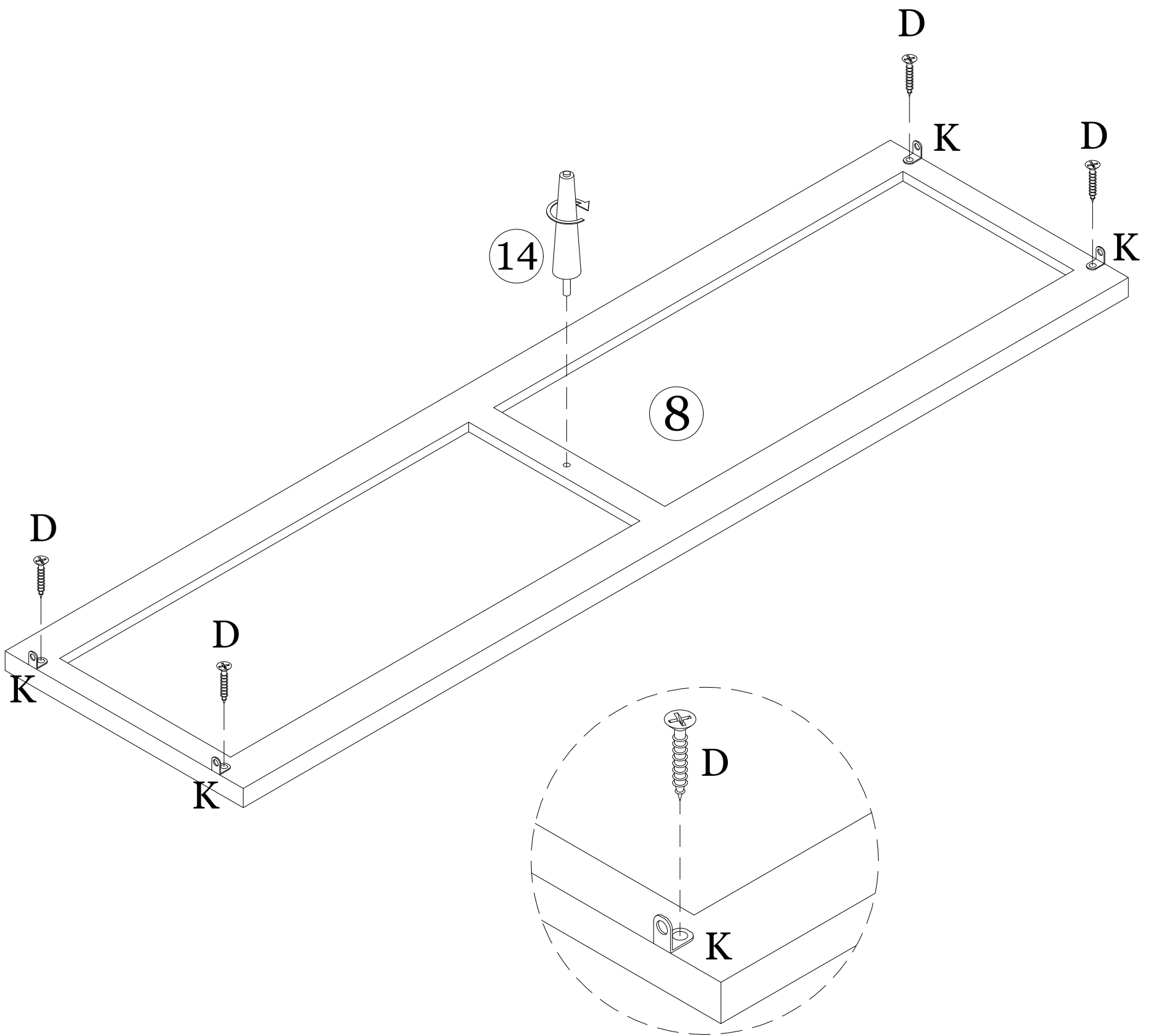
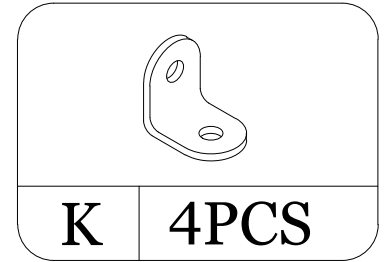
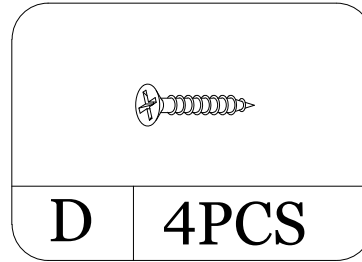

INSTALLATION STEPS

STEP 11

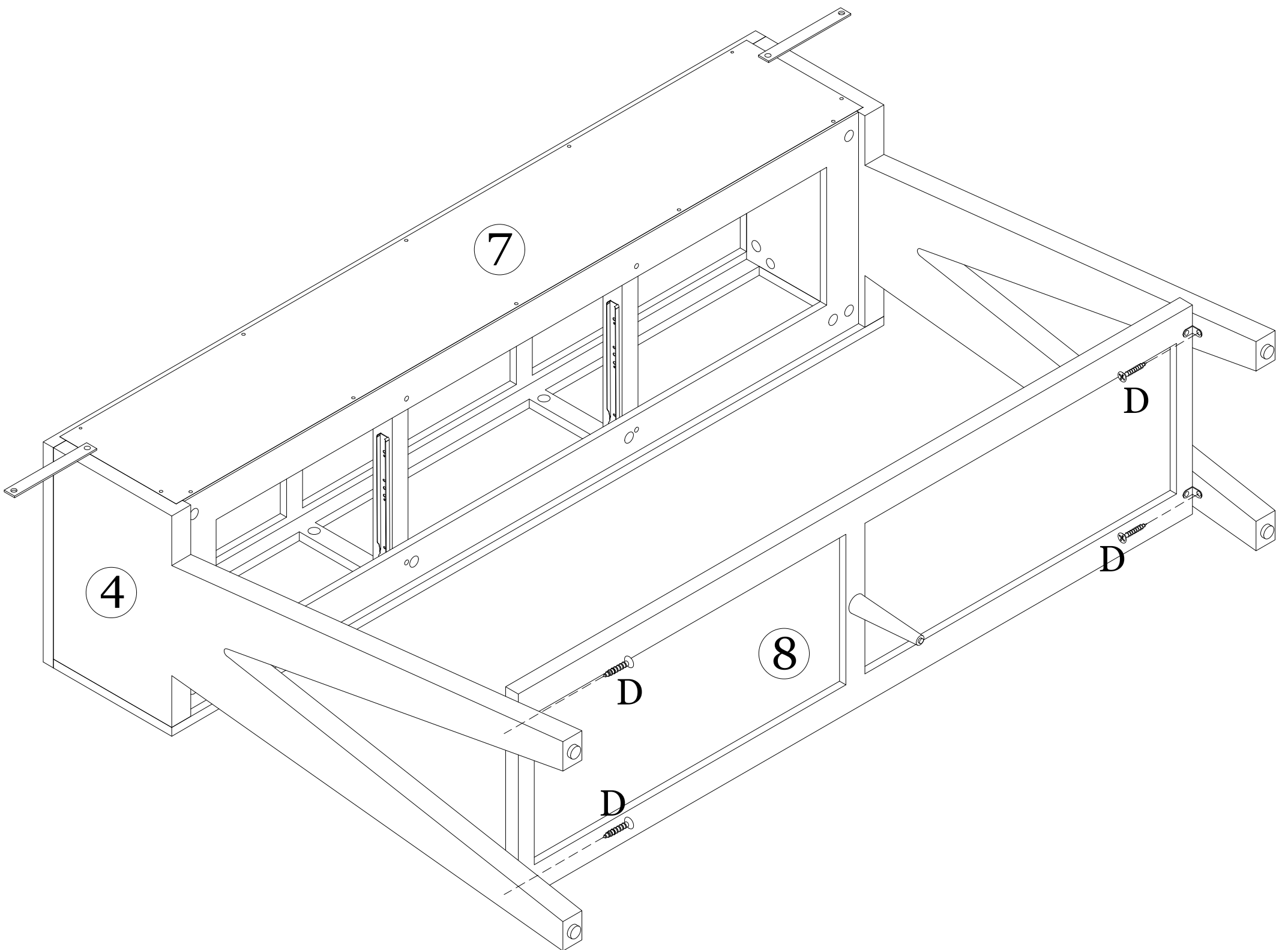
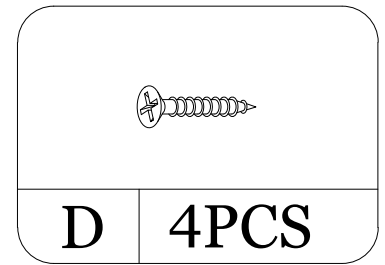

INSTALLATION STEPS

STEP 12

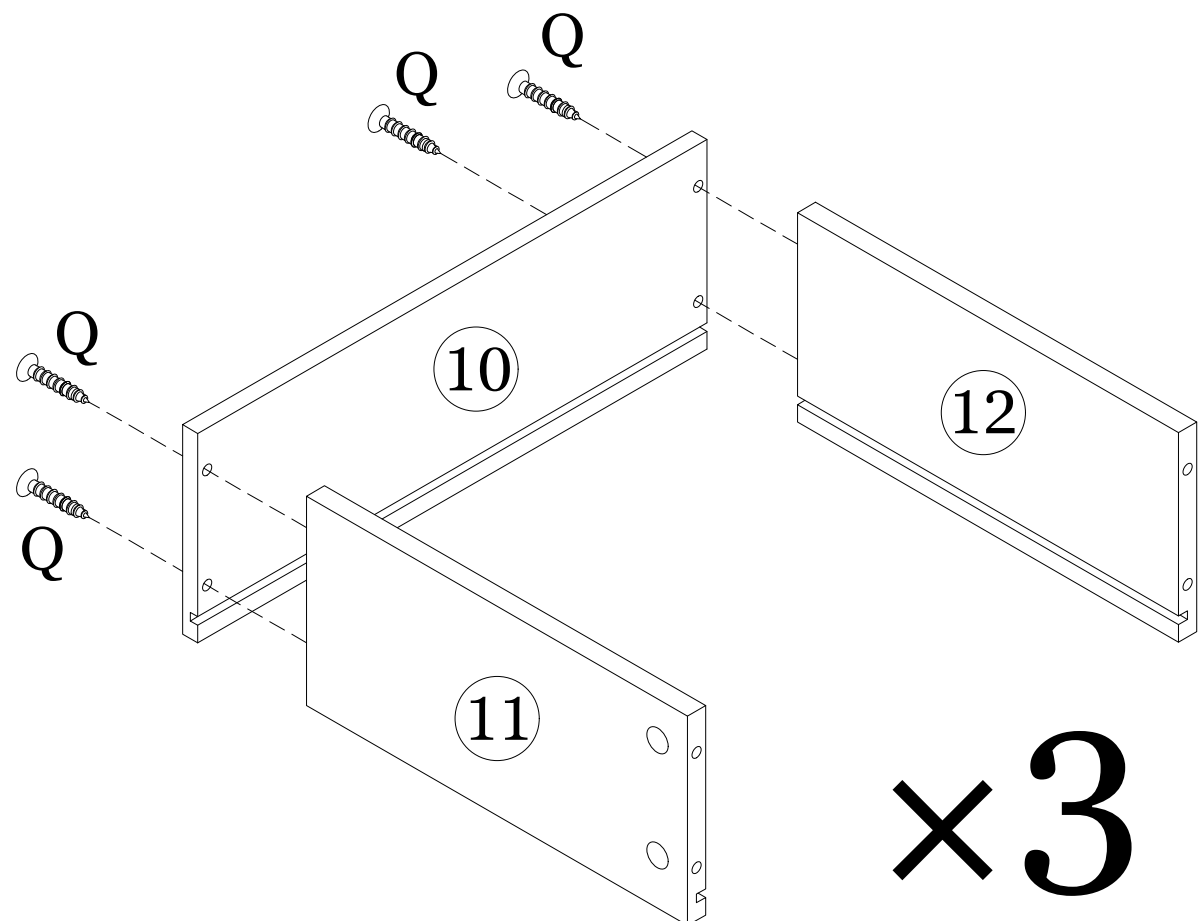
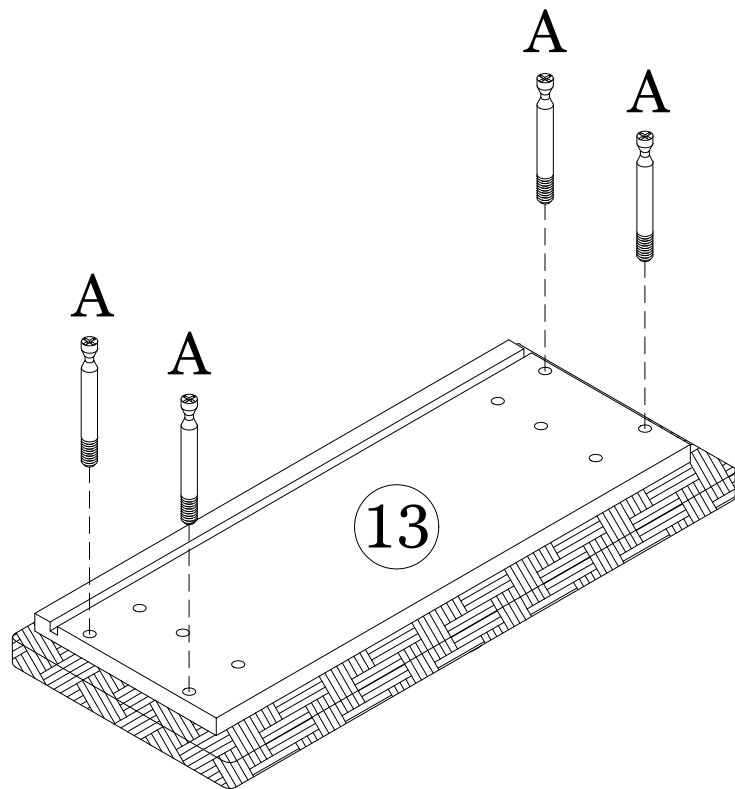
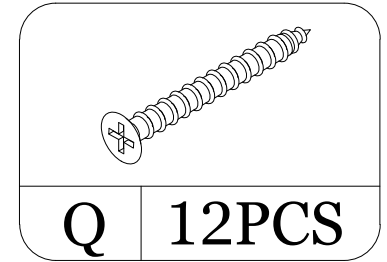
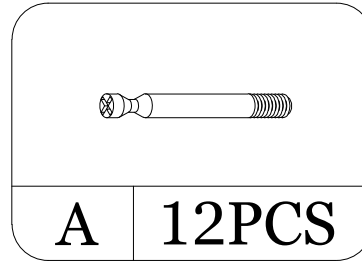

INSTALLATION STEPS

STEP 13

	
B	12PCS

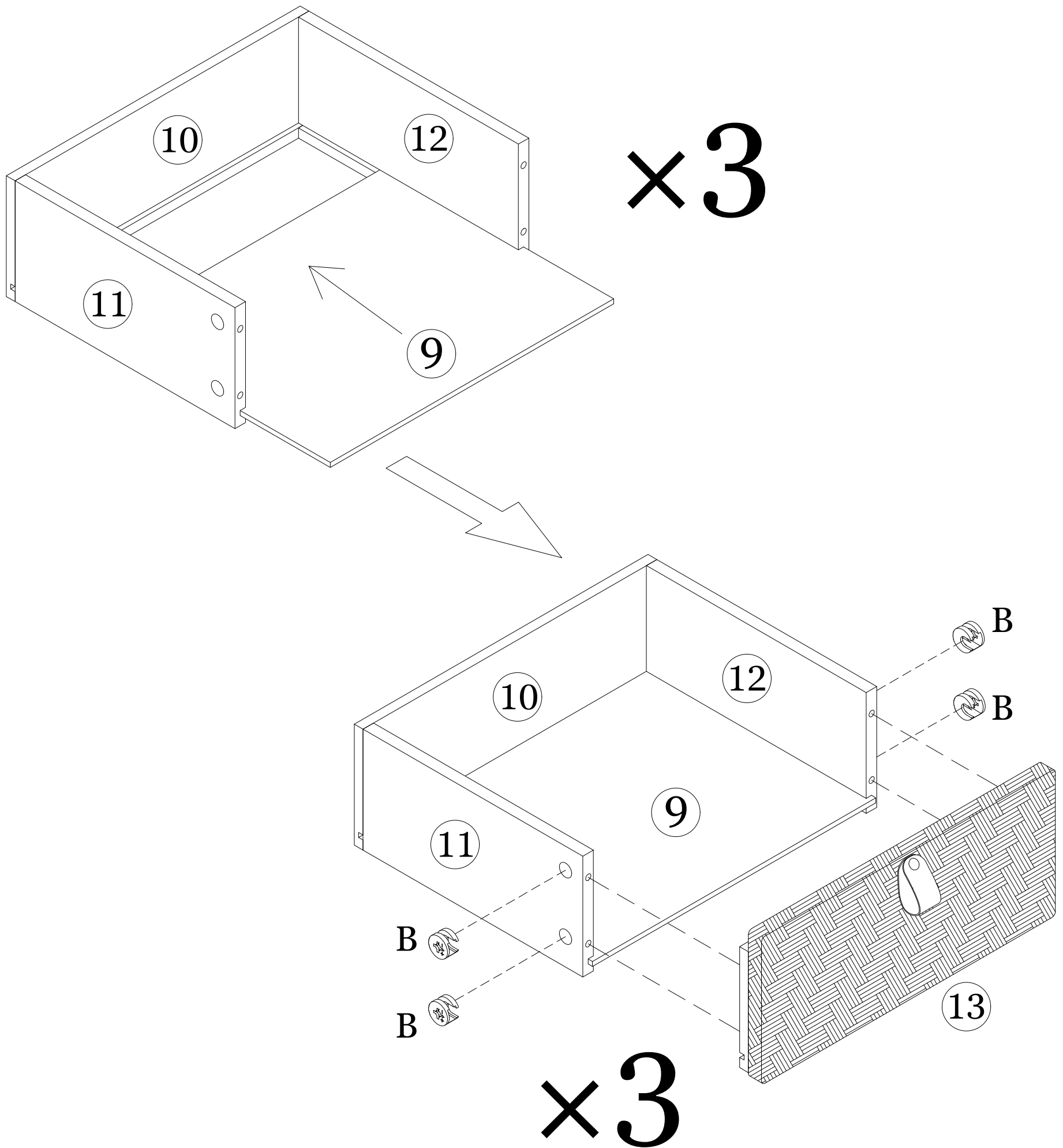

INSTALLATION STEPS

STEP 14

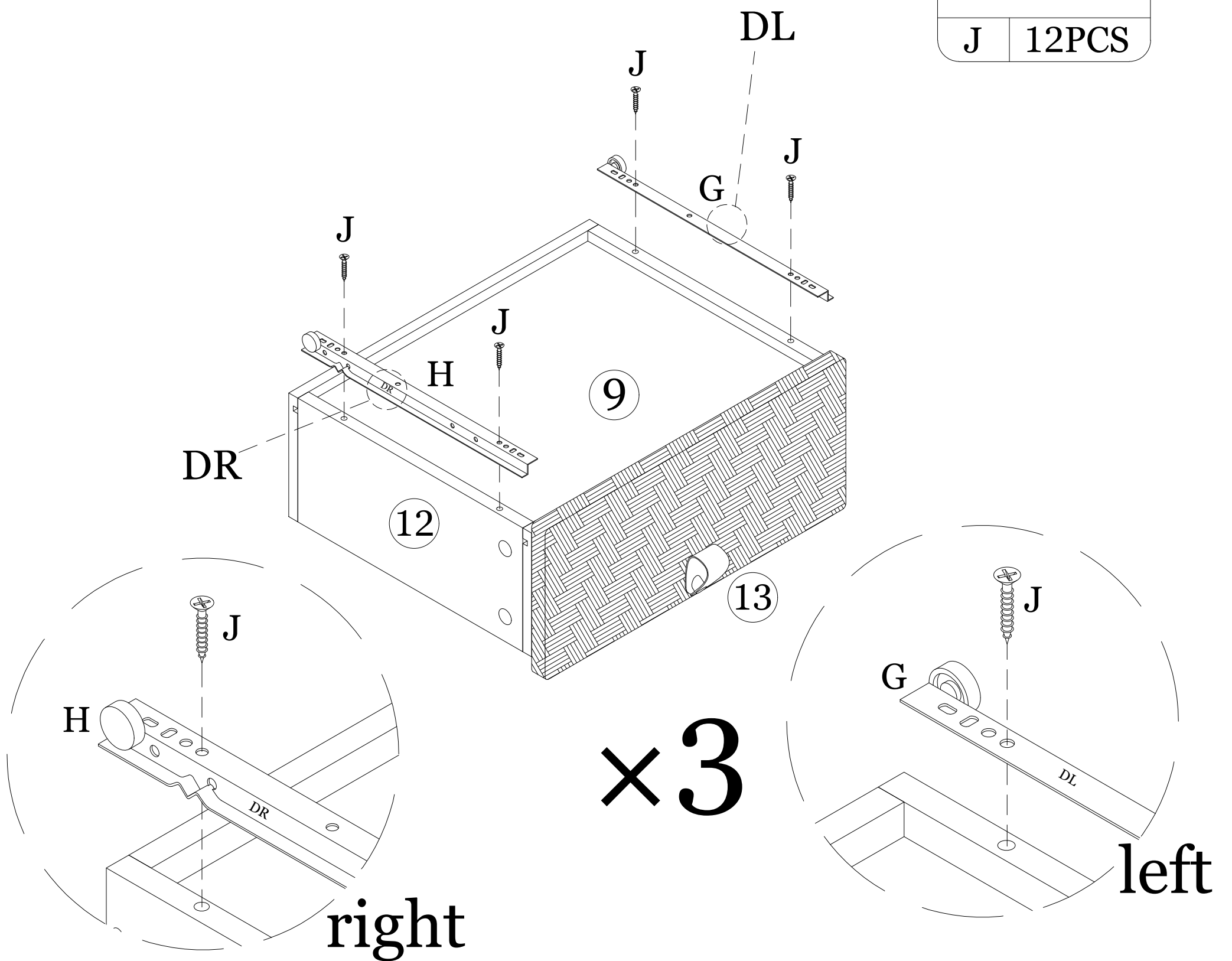
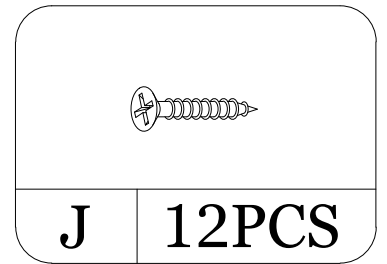
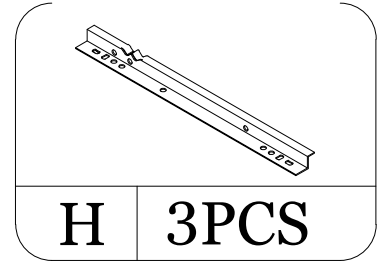
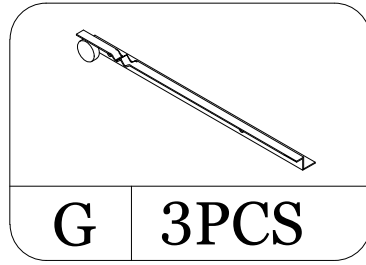

INSTALLATION STEPS

STEP 15

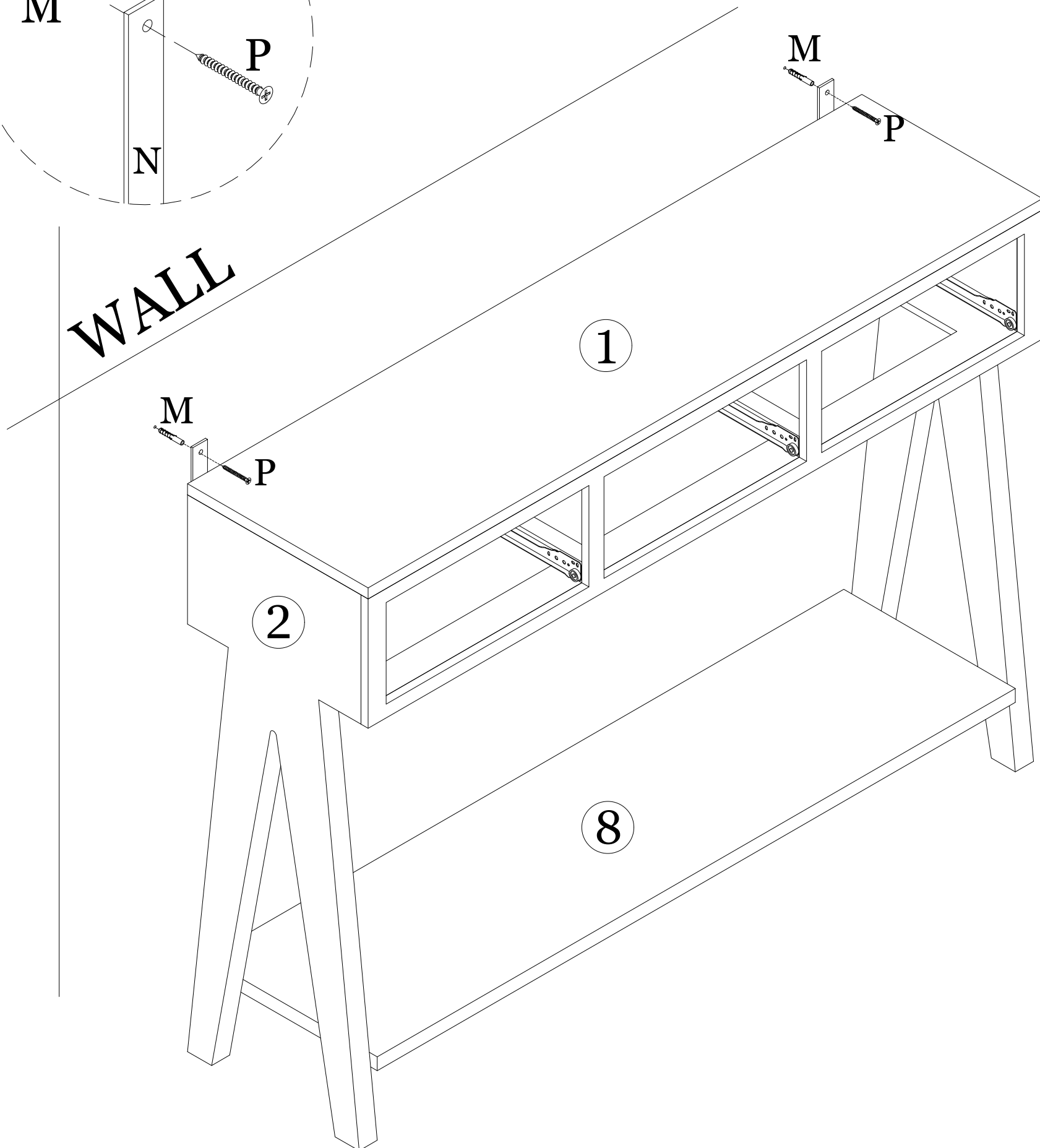
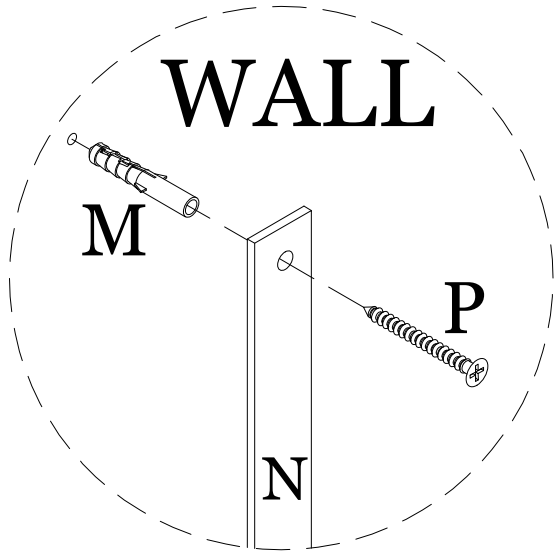
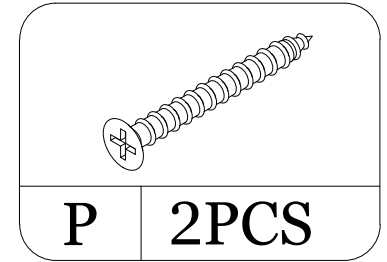
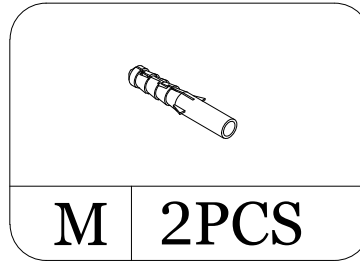

INSTALLATION STEPS

STEP 16

