

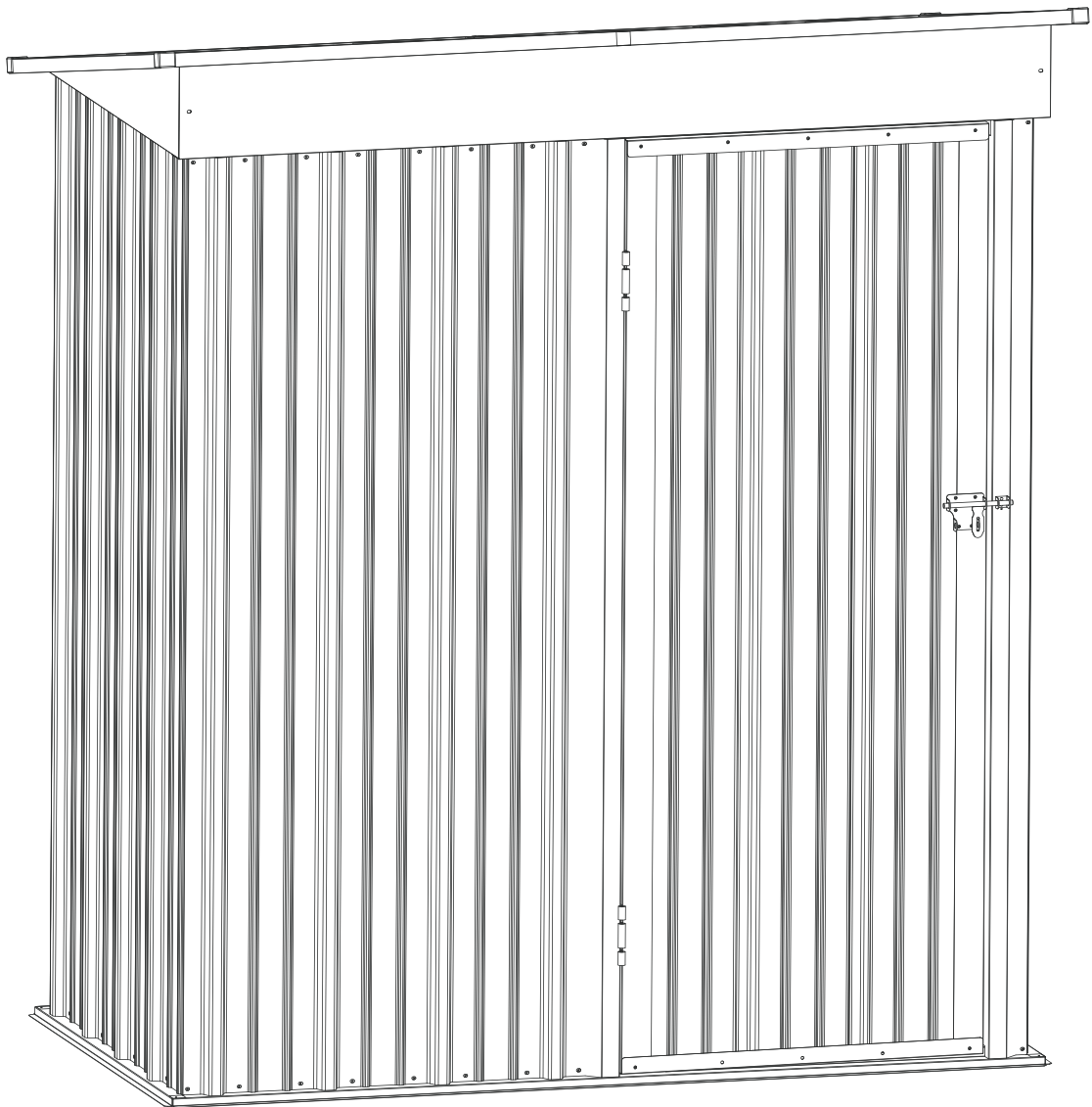

ASSEMBLY INSTRUCTIONS

SKU: 53FT



 hellovitesse@gmail.com

 +1(503) 928-7812

HOPE YOU HAVE A PERFECT SHOPPING EXPERIENCE!

Our product is designed with excellence crafted from premium materials, and exhibits a unique sense of style. Every detail has been thoughtfully considered to bring both elegance and functionality to your space.

Whether in the office or at home, our product offers long-lasting performance and versatile use. We believe it will enhance your environment and make your daily tasks easier.

If you encounter any issues or have questions, please don't hesitate to contact our dedicated customer service team. We are always here to assist and ensure your satisfaction.



IMPORTANT SAFETY INSTRUCTIONS











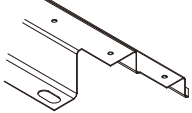
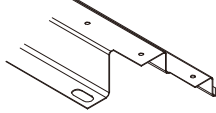
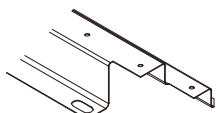
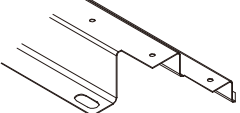
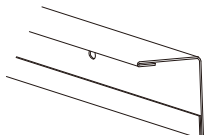
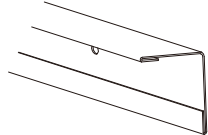
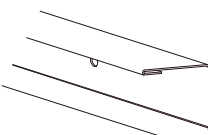
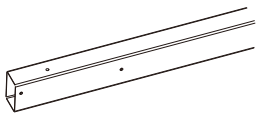
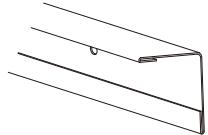
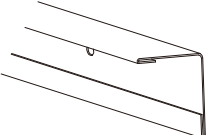
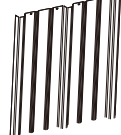

Read these instructions carefully and retain them for future use.

When using the product, basic safety precautions always be followed to reduce the risk of injury, including the following:

- This product must be assembled by an adult.
- Keep children and pets away while assembling the product.
- Remove all the packing materials and review all components before assembly.
- Do not over-tighten the fasteners.
- To avoid scratching the floor, assemble the product on a soft surface, such as a carpet.
- Do not use this product if any parts are missing, damaged, or worn.
- Always use the product on a firm, level ground.
- Do not let the children climb on or play with the product.
- Keep all sharp objects away from the upholstery.
- Regularly examine the product for wear and tear. Stop using the product at the first sign of damage or if the parts detached.

Attention: Please wear gloves when you install this product. The edge of the shed may cause damage, please be attentive.

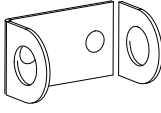
PARTS LIST

<p>Base plate 1</p>  <p>B1 Qty: 1</p>	<p>Base plate 2</p>  <p>B2 Qty: 1</p>	<p>Left side of Base</p>  <p>BL Qty: 1</p>	<p>Right side of Base</p>  <p>BR Qty: 1</p>
<p>Left upper plate</p>  <p>L1 Qty: 1</p>	<p>Right upper plate</p>  <p>L2 Qty: 1</p>	<p>Upper plate 3</p>  <p>L3 Qty: 1</p>	<p>Upper plate 1</p>  <p>UP1 Qty: 1</p>
<p>Eave</p>  <p>M3 Qty: 4</p>	<p>Side eave</p>  <p>M4 Qty: 2</p>	<p>Wall panel 1</p>  <p>W1A Qty: 5</p>	<p>Wall panel 2</p>  <p>W2A Qty: 4</p>
<p>Wall panel 3</p>  <p>W3A Qty: 1</p>	<p>Left post</p>  <p>ULA Qty: 1</p>	<p>Right post</p>  <p>URA Qty: 1</p>	<p>Plate 20</p>  <p>20 Qty: 2</p>
<p>Left door</p>  <p>DL1 Qty: 1</p>	<p>Right door</p>  <p>DR1 Qty: 1</p>	<p>Bracket</p>  <p>DF Qty: 1</p>	<p>Plate for fixing door</p>  <p>DX1 Qty: 2</p>

PARTS LIST

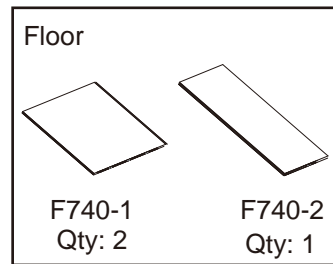
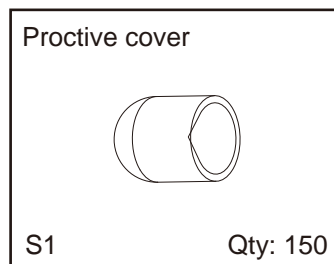
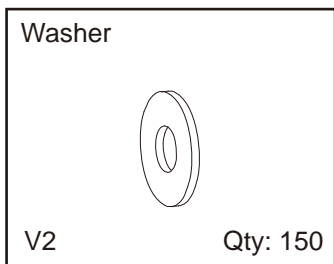
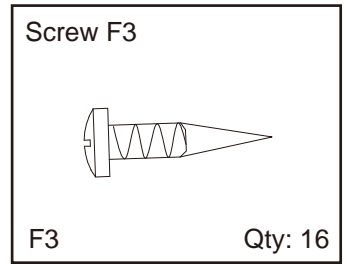
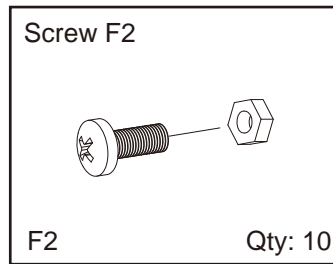
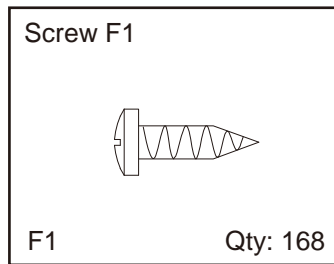
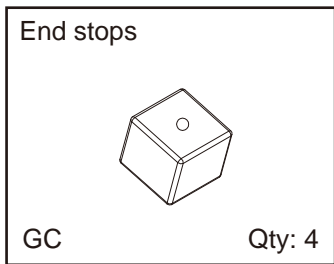
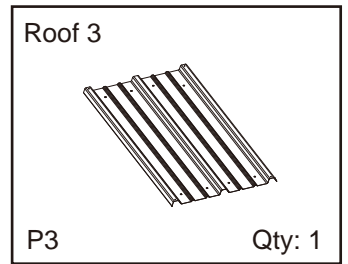
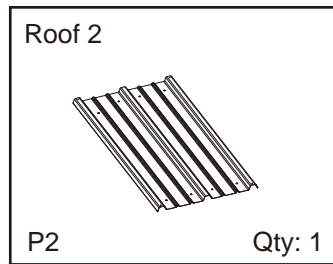
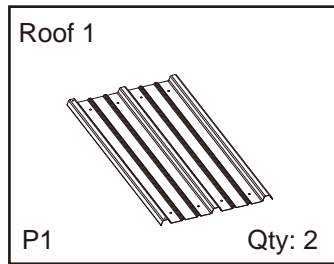
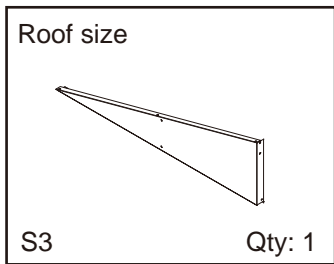
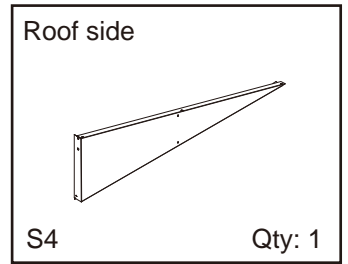
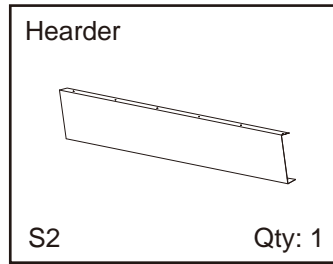
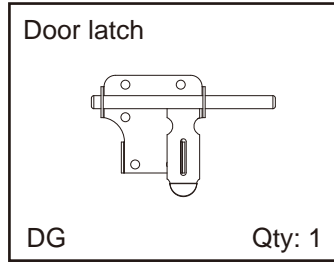
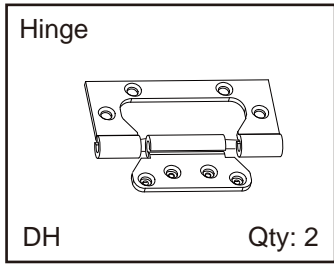

INSTALLATION STEPS

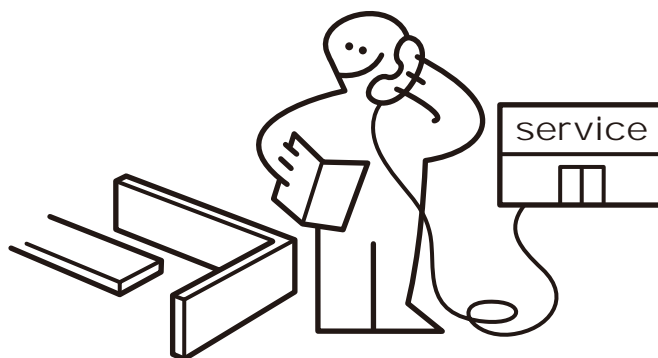
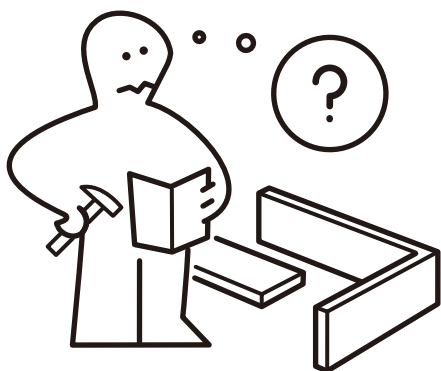
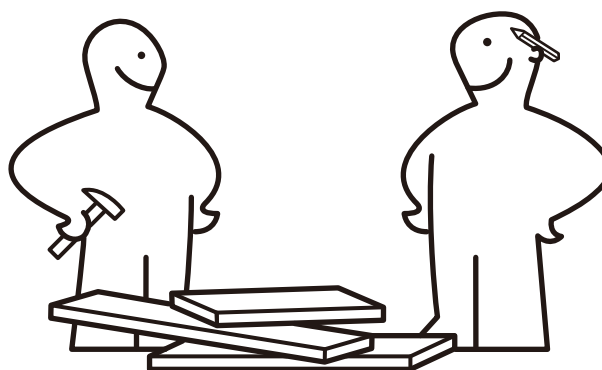
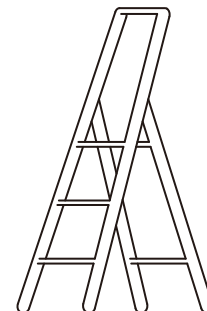
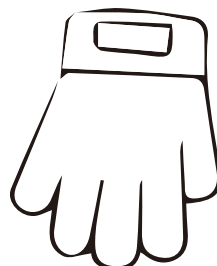

NOTICE

Considering the large number of parts, the installation process is divided into four major steps.

Major Step 1: Assemble the base.

Major Step 2: Assemble the wall (except the side with the door).

Major Step 3: Assemble the wall (with the door).

Major Step 4: Assemble the roof.





Major Step 5: Assemble the door.

Major Step 6: Assemble the floor.

Please pay attention to the edges of the product, which are easily cut.

INSTALLATION STEPS

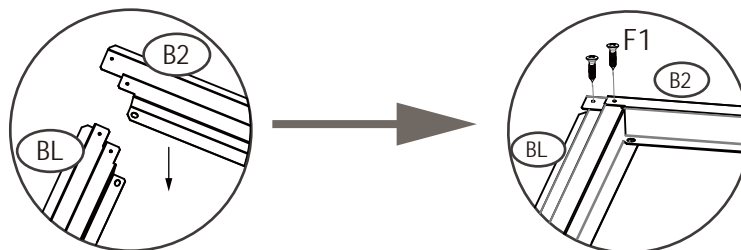

Major Step 1: Assemble the base

PART	NO.	Qty.
	B1	1
	B2	1
	BL	1
	F1	4

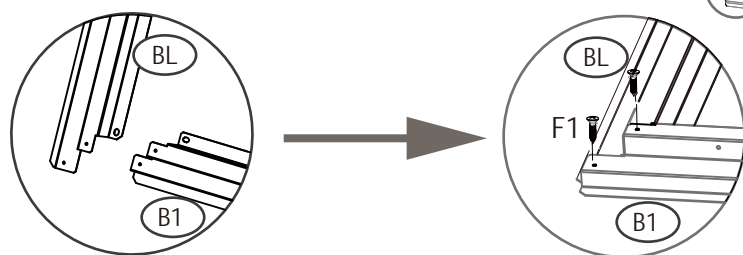
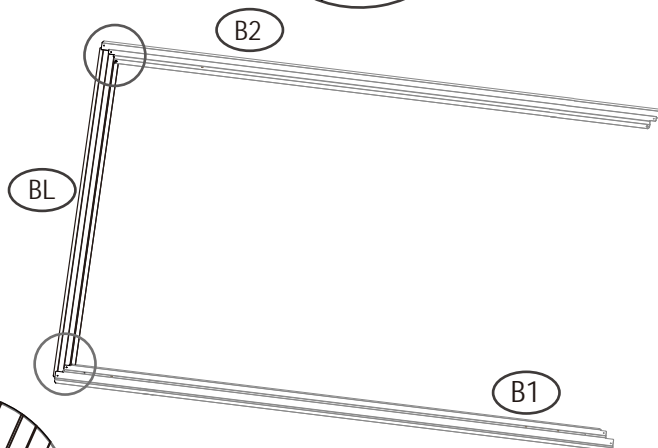

Match the holes in B2, BL, and B1, then align them with Screw F1.
 Note: Please drop these parts in flat floor.



PART	NO.	Qty.
	BR	1
	F1	4

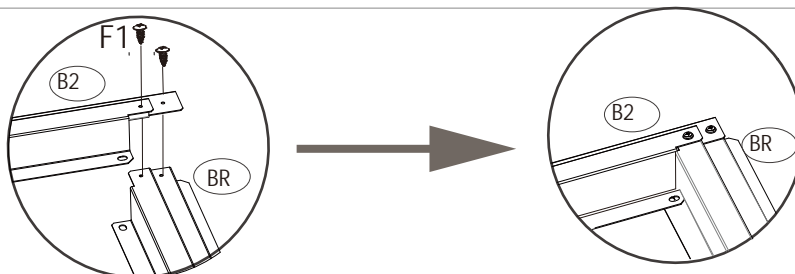

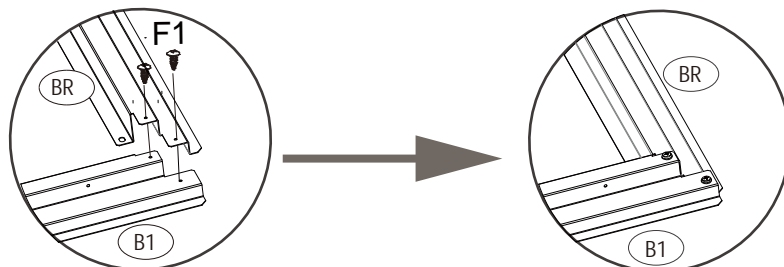
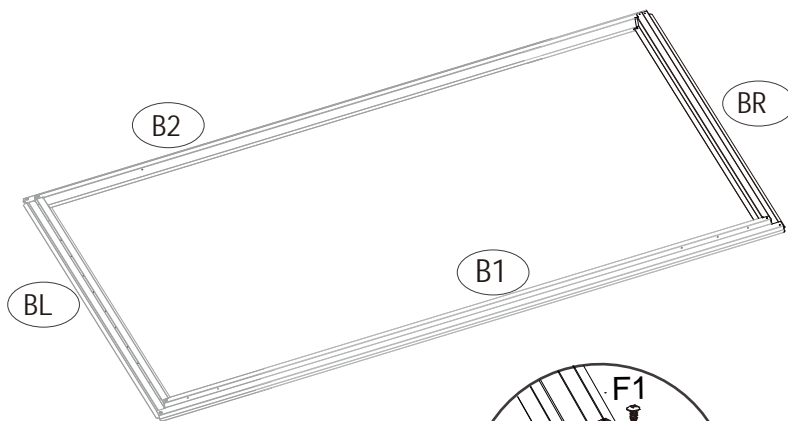

Please connect the BR with B2 and B1 via Screw F1.





INSTALLATION STEPS

Major Step 2: Assemble the wall

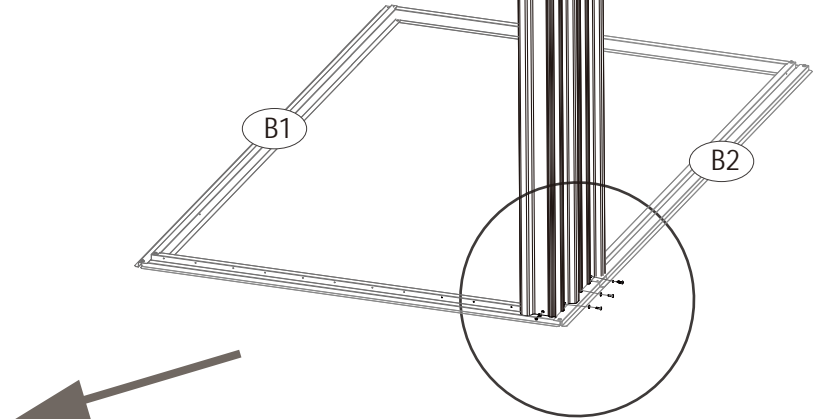
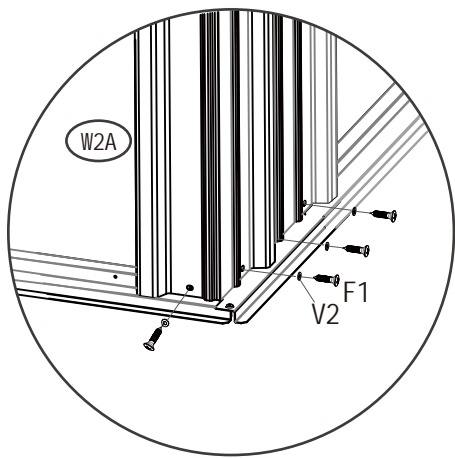
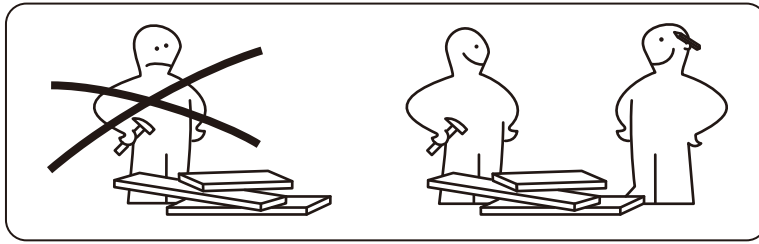
PART	NO.	Qty.
	W2A	1
	F1	4
	V2	4



Connect W2A with B2 via Washer V2 and Screw F1.
 Note: The angles of the B1&B2 and W2A are right-angles, please align them carefully. Two people needed for this step.

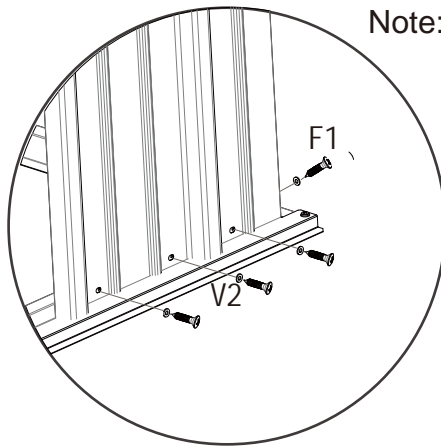

PART	NO.	Qty.
	W2A	1
	F1	4
	V2	4



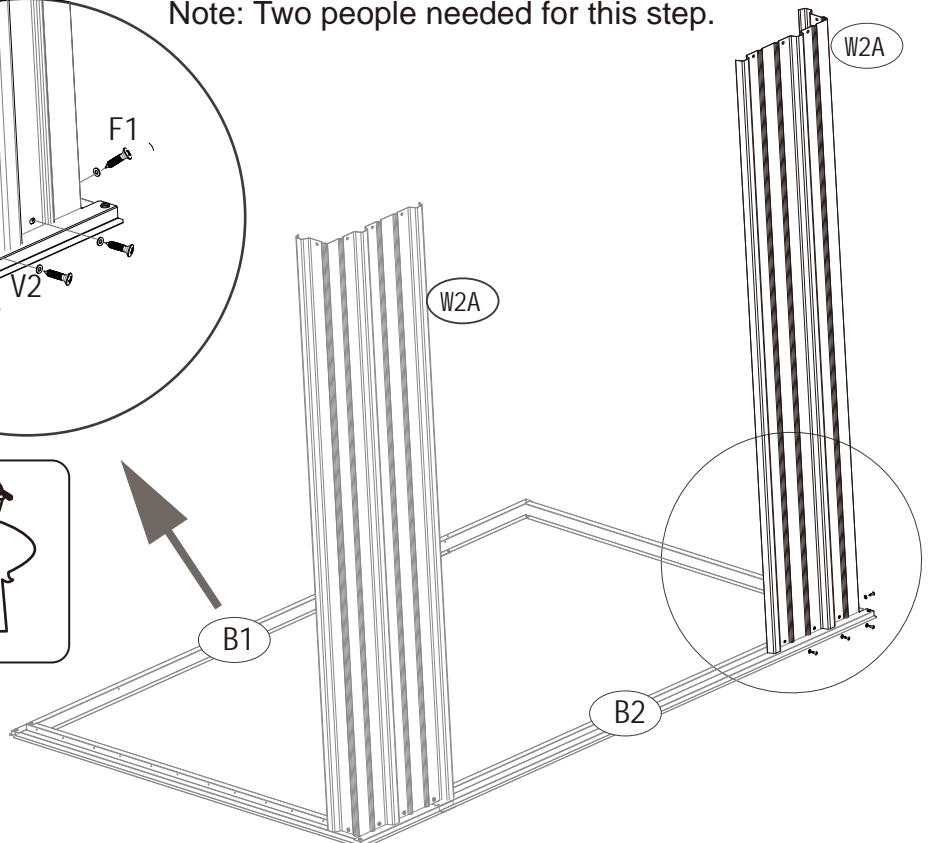
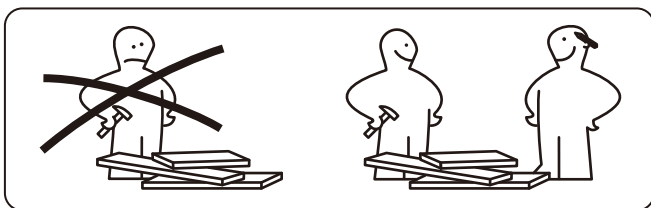



Connect W2A with B2 via Washer V2 and Screw F1.
 Note: Two people needed for this step.

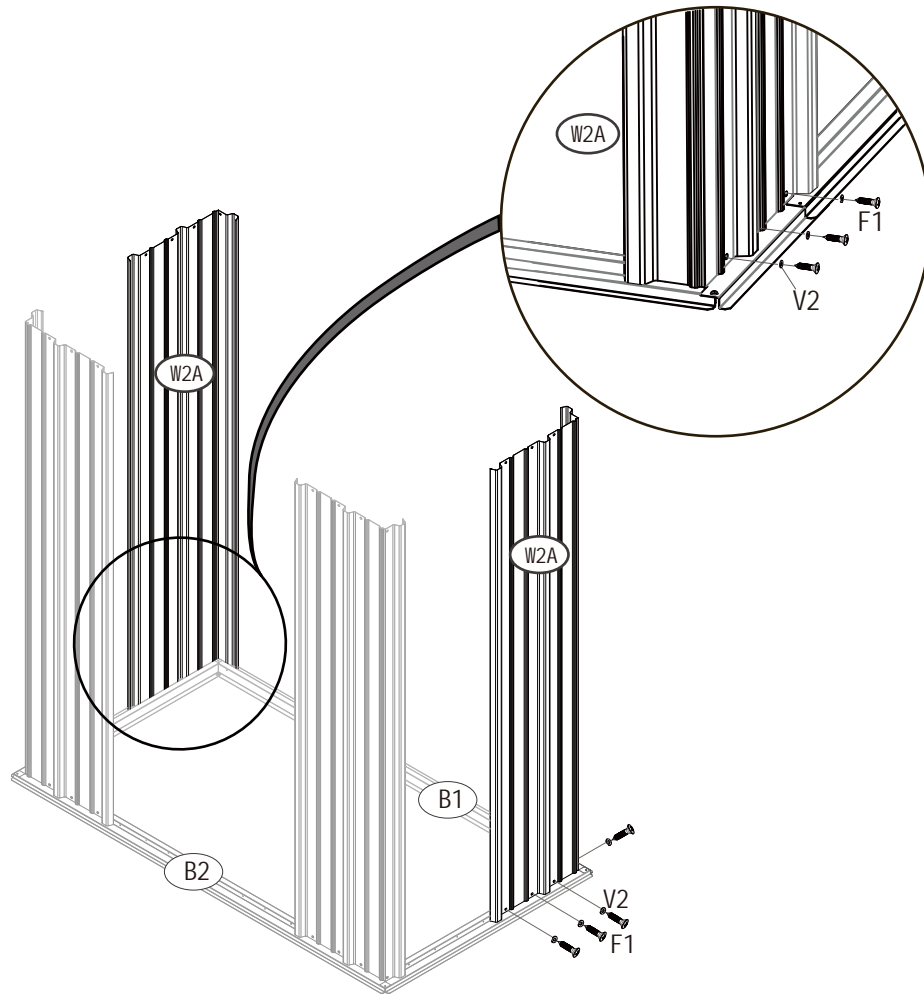

INSTALLATION STEPS

PART	NO.	Qty.
	W2A	2
	F1	7
	V2	7





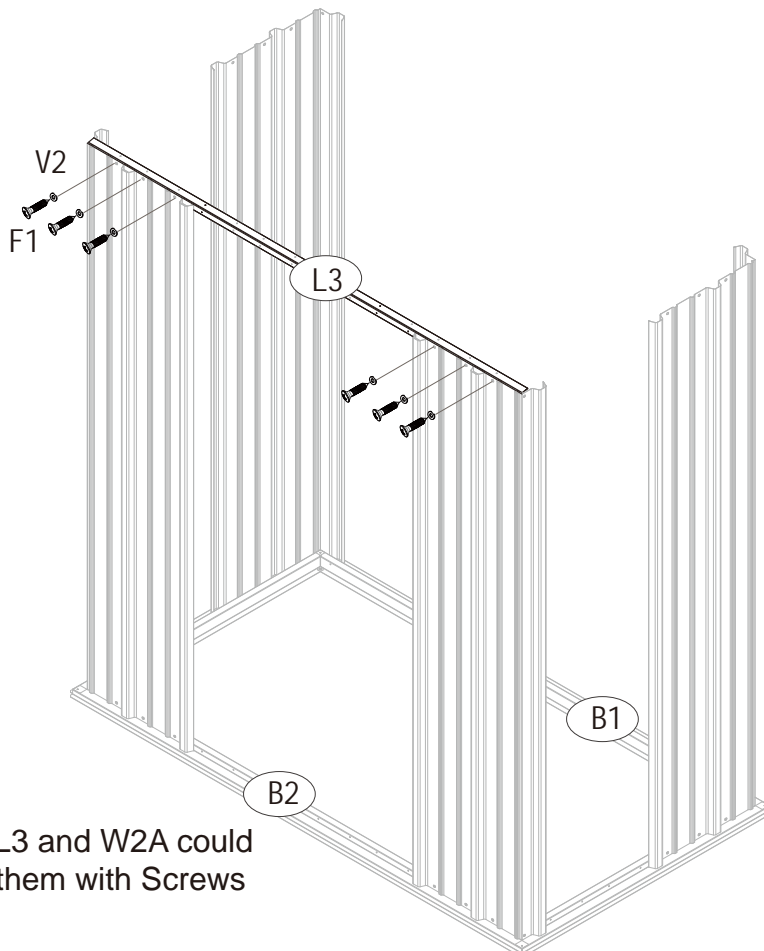

PART	NO.	Qty.
	L3	1
	F1	6
	V2	6





Make sure the screws holes in the L3 and W2A could match with each others, then align them with Screws F1 and Washer V2.

INSTALLATION STEPS

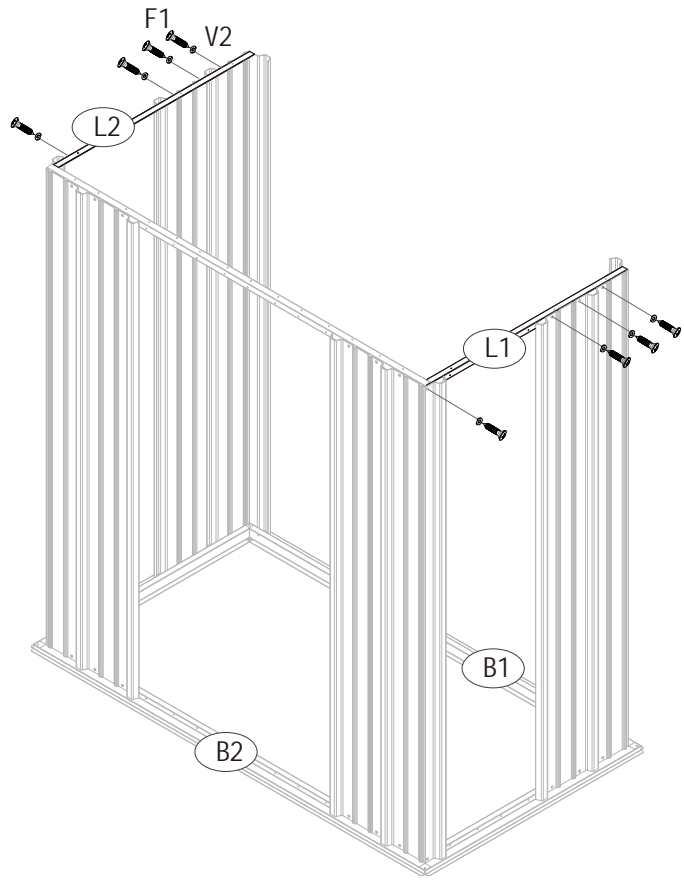

PART	NO.	Qty.
	L1	1
	L2	1
	F1	8
	V2	8

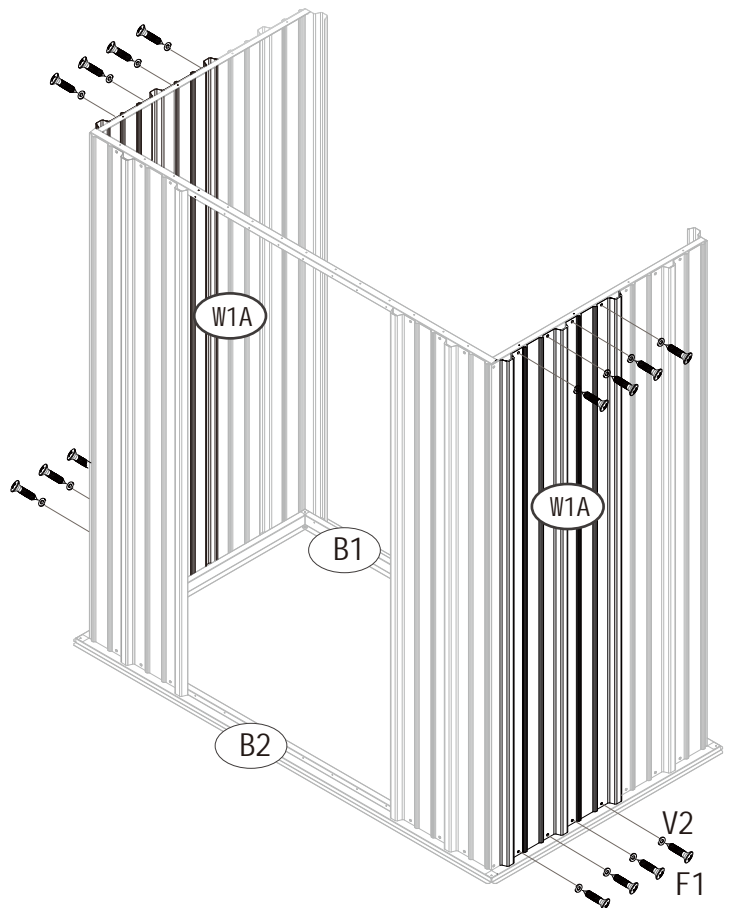

PART	NO.	Qty.
	W1A	2
	F1	16
	V2	16



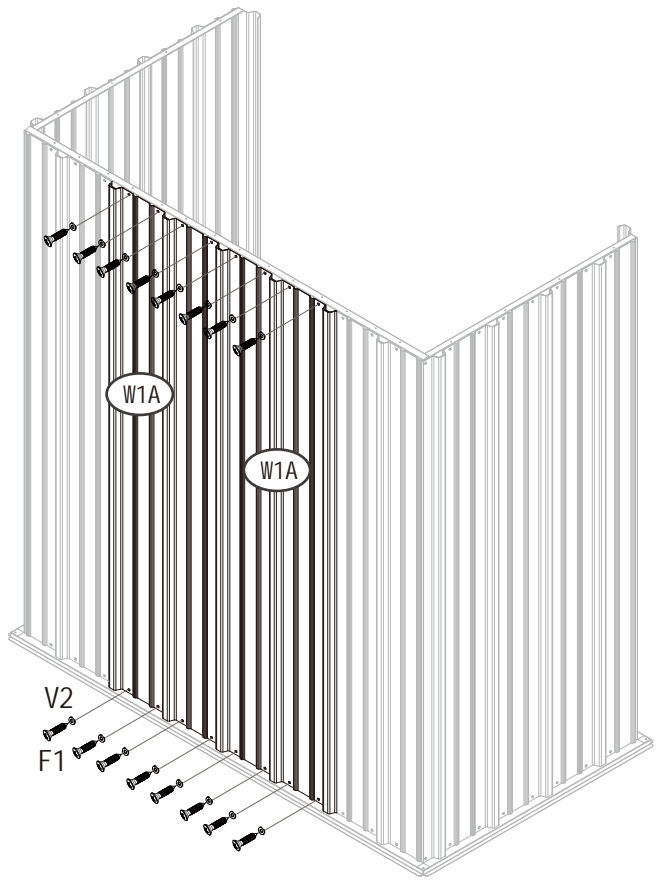

INSTALLATION STEPS

PART	NO.	Qty.
	W1A	2
	F1	16
	V2	16





Major Step 3: Assemble the wall

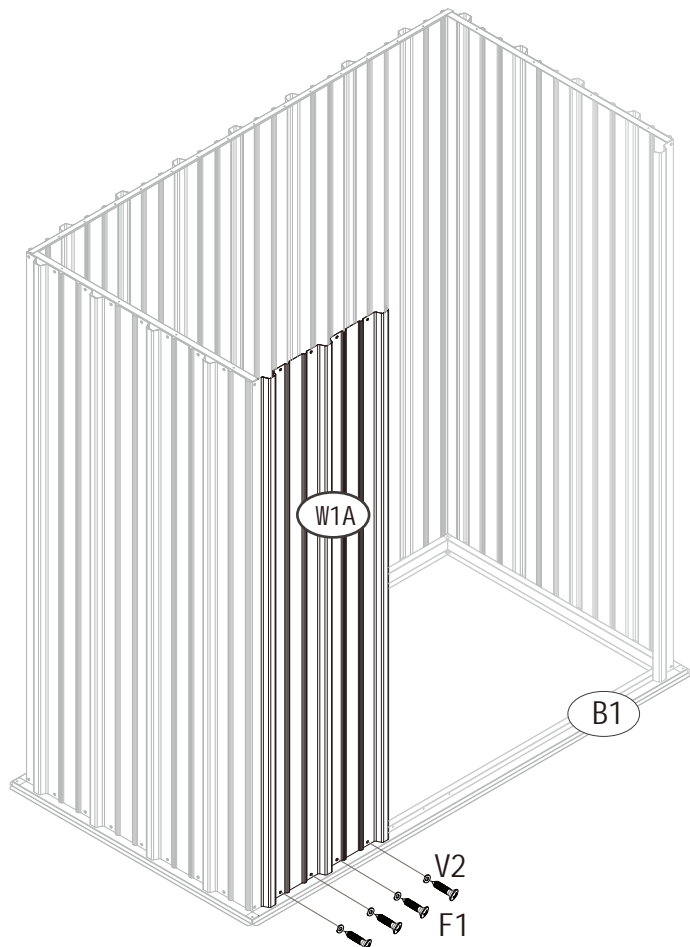

PART	NO.	Qty.
	W1A	1
	F1	4
	V2	4



INSTALLATION STEPS

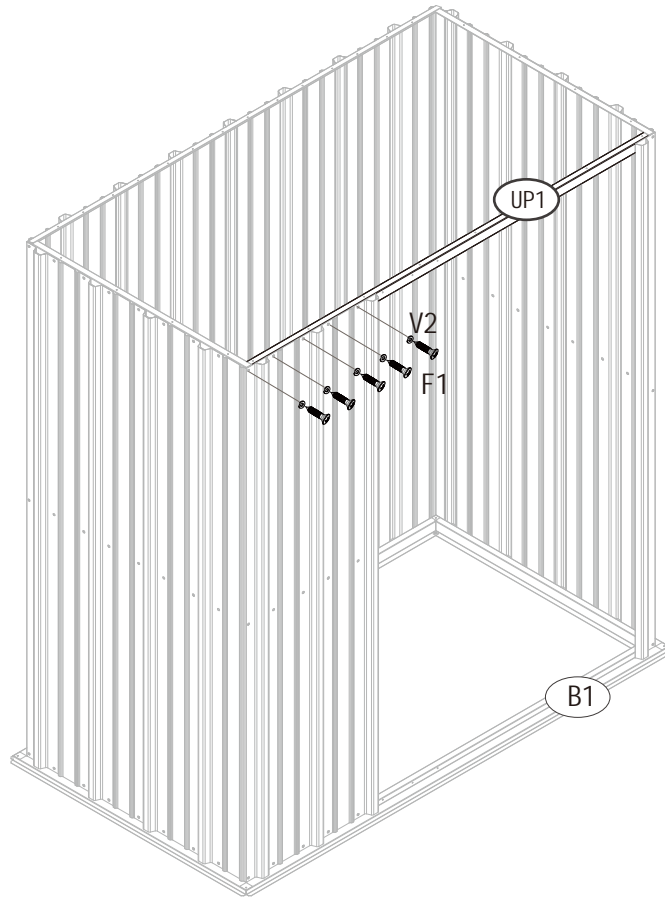



PART	NO.	Qty.
	UP1	1
	F1	5
	V2	5

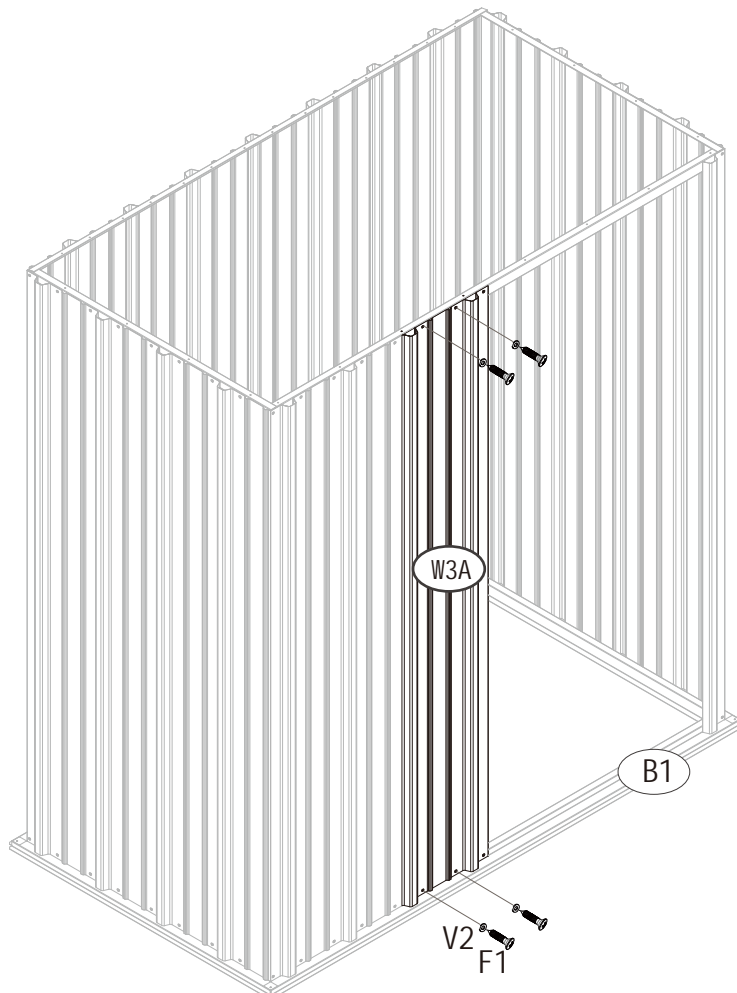

PART	NO.	Qty.
	W3A	1
	F1	4
	V2	4



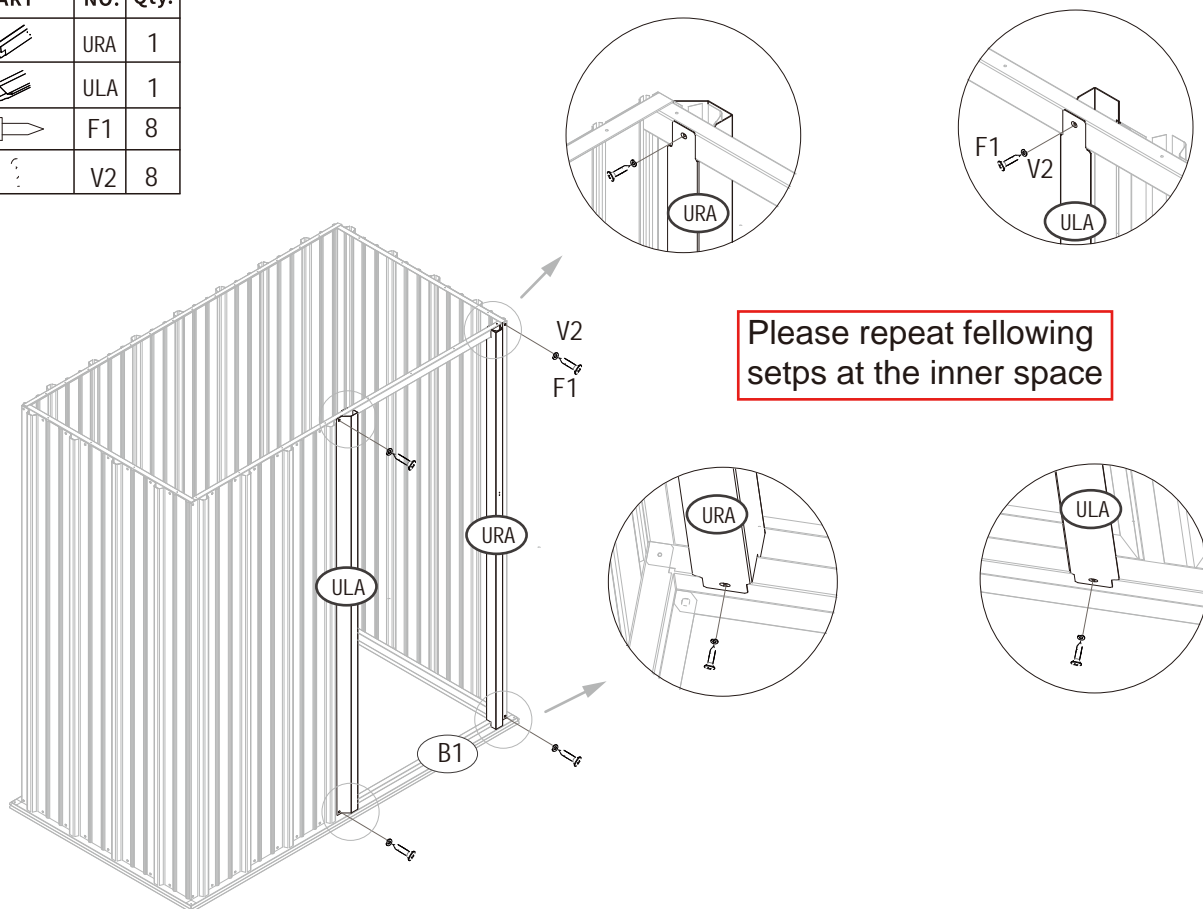

INSTALLATION STEPS

PART	NO.	Qty.
	URA	1
	ULA	1
	F1	8
	V2	8





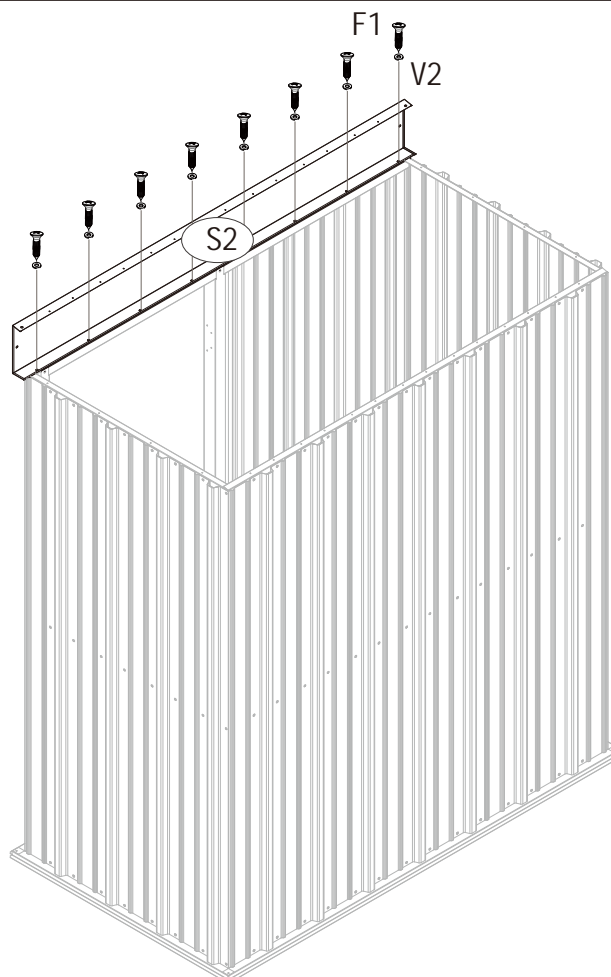

Major Step 4: Assemble the roof

PART	NO.	Qty.
	S2	1
	F1	8
	V2	8





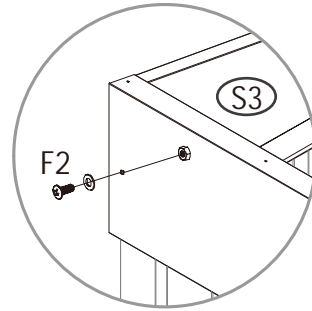
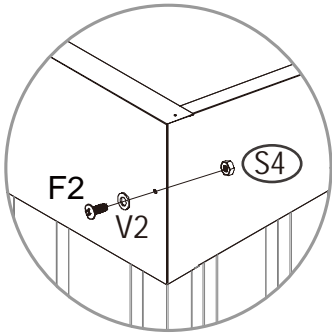
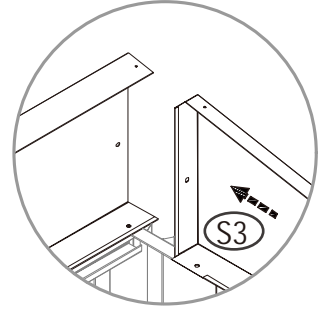
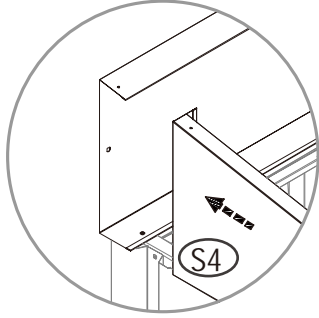
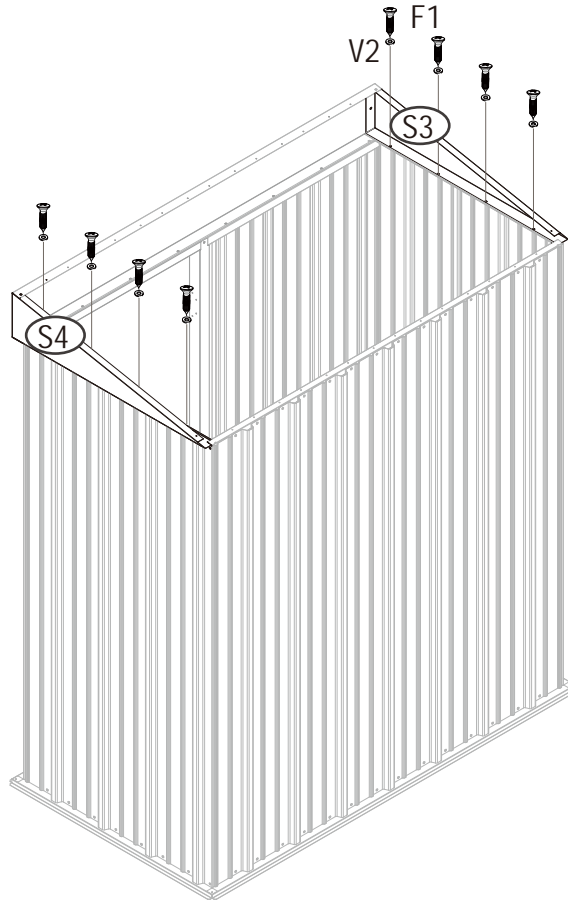

Please be carefull of the edge when install the Srews F1. Gloves are needed during installation.

INSTALLATION STEPS

PART	NO.	Qty.
	S3	1
	S4	1
	F1	8
	V2	10
	F2	2



Slide the S3 into the S2, making the screws holes on S3 and S2 can match with each other.

PART	NO.	Qty.
	P1	2
	P2	1
	P3	1
	F1	32
	V2	32

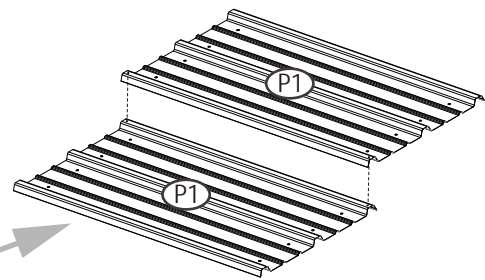
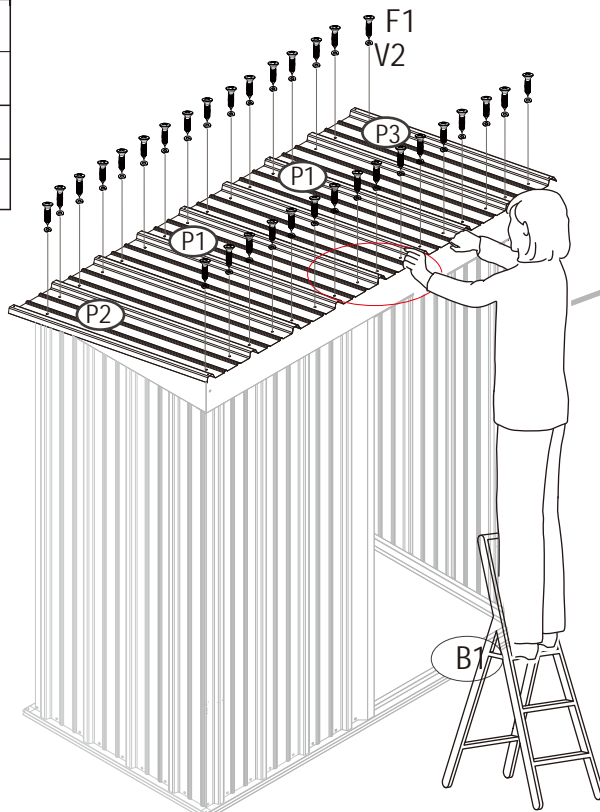

Please pay attention to the installation of roof panels!

INSTALLATION STEPS

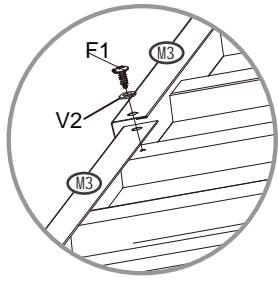



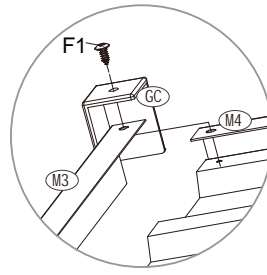

x2

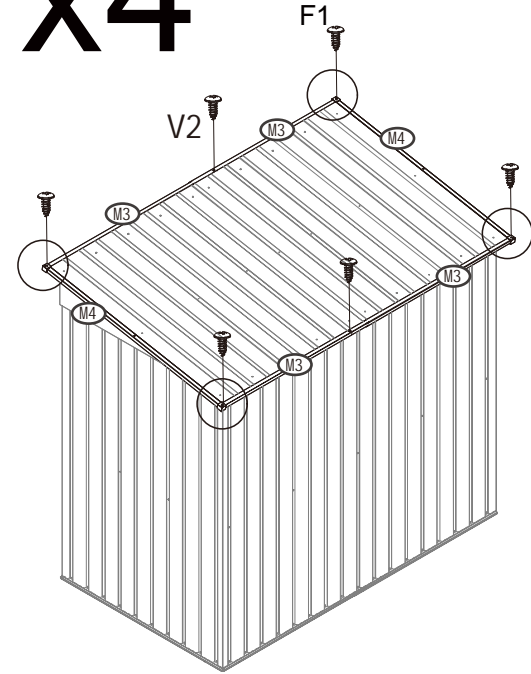
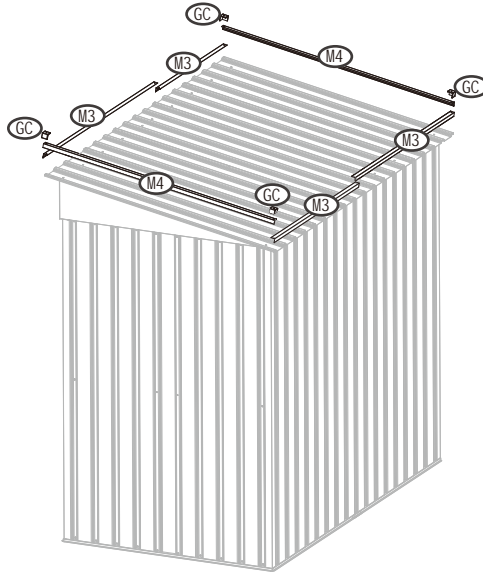

x4



PART	NO.	Qty.
	M3	4
	M4	2
	GC	4
	F1	6
	V2	2



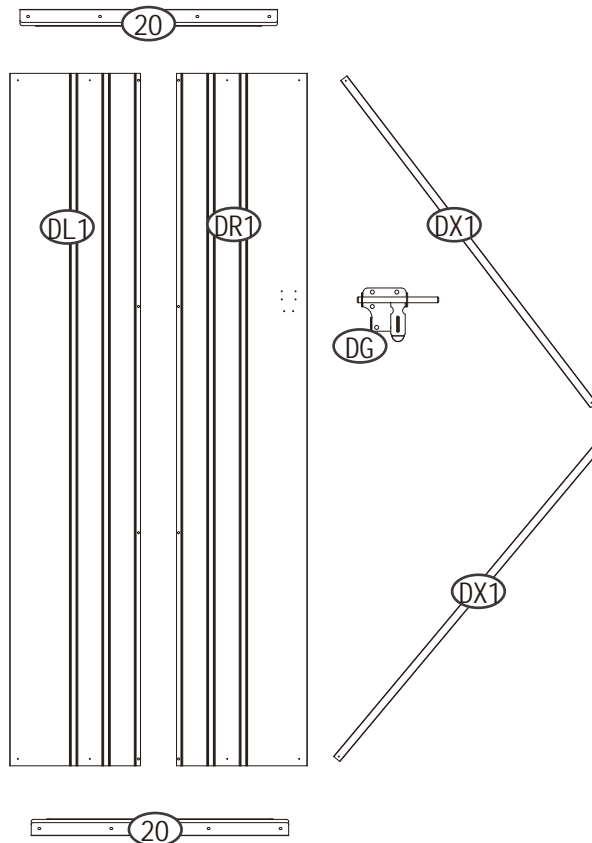



Please note the direction of Part GC is correct.



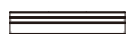

INSTALLATION STEPS

Major Step 5: Assemble the door

Use Part 20 to fix DL1 and DR1, then install the door latch.
 Note: The side with door latch is facing outside.

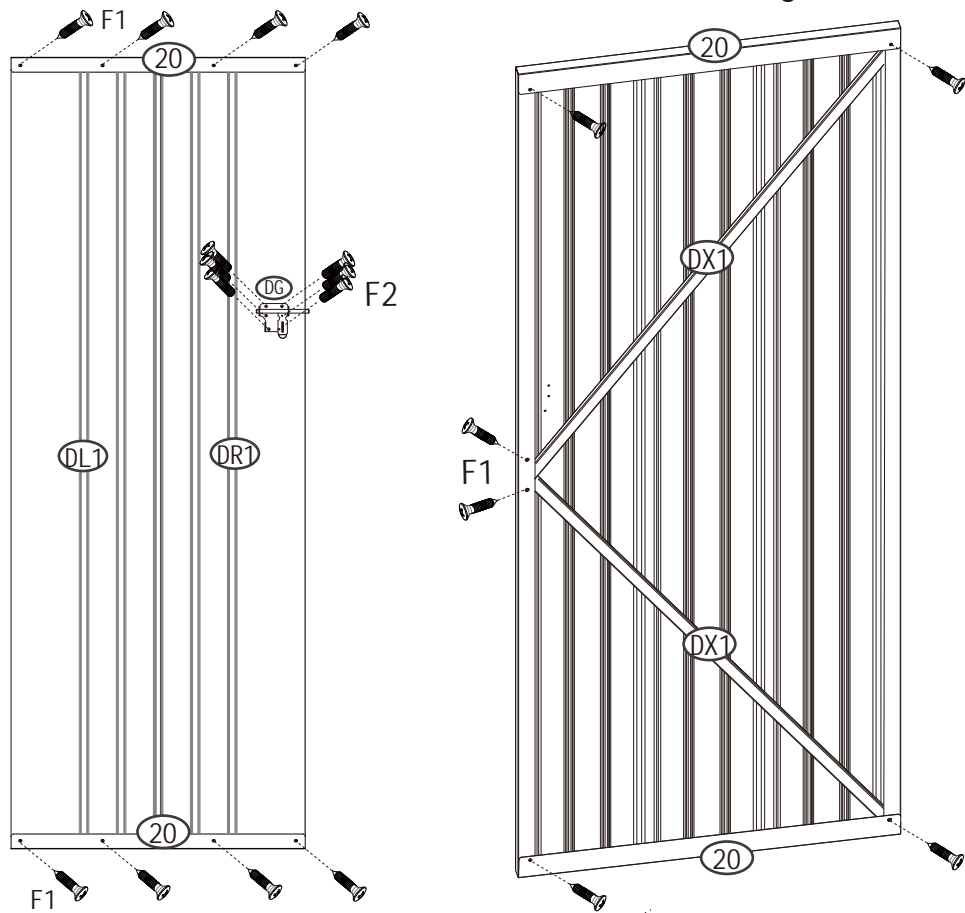
PART	NO.	Qty.
	DX1	2
	20	2
	DL1	1
	DR1	1
	DG	1
	F1	14
	F2	6



PART	NO.	Qty.
	DH	2
	F3	8

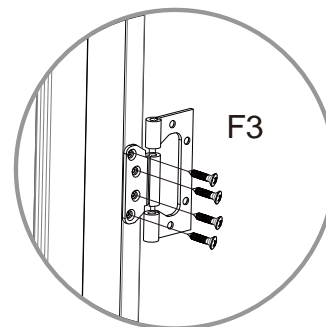
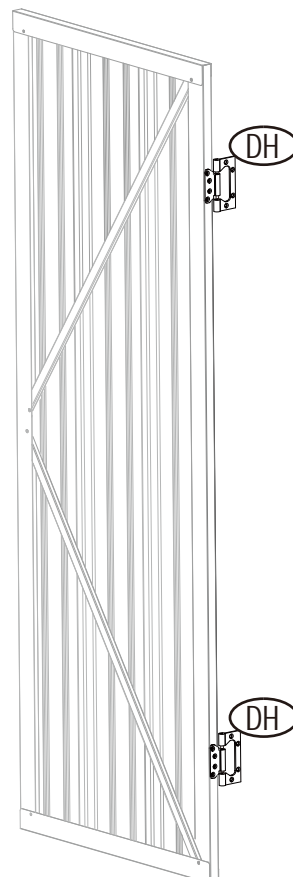

Install the Hinge on the another side compare with Door Latch.
 Note: The correct side already be noted in the guidance.

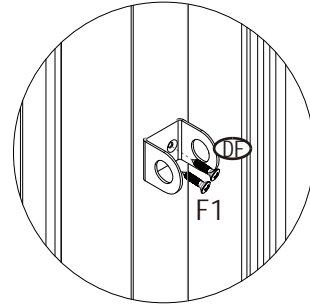
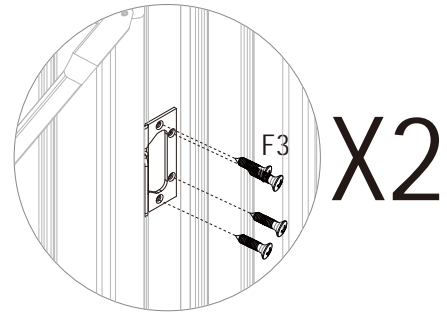

X2

INSTALLATION STEPS



PART	NO.	Qty.
	DF	1
	F3	8
	F1	2

PART	NO.	Qty.
	S1	122

Note: there are protective cap S1 when install the screws, in case of scratch by screws.

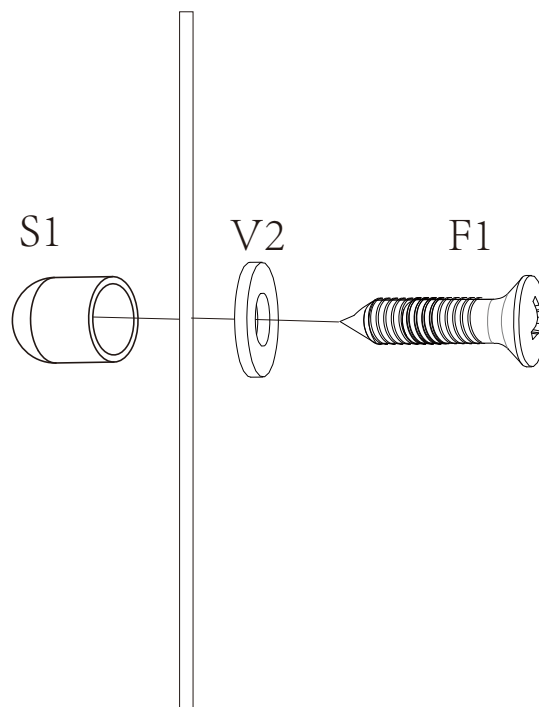

INSTALLATION STEPS

Major Step 6: Assemble the floor

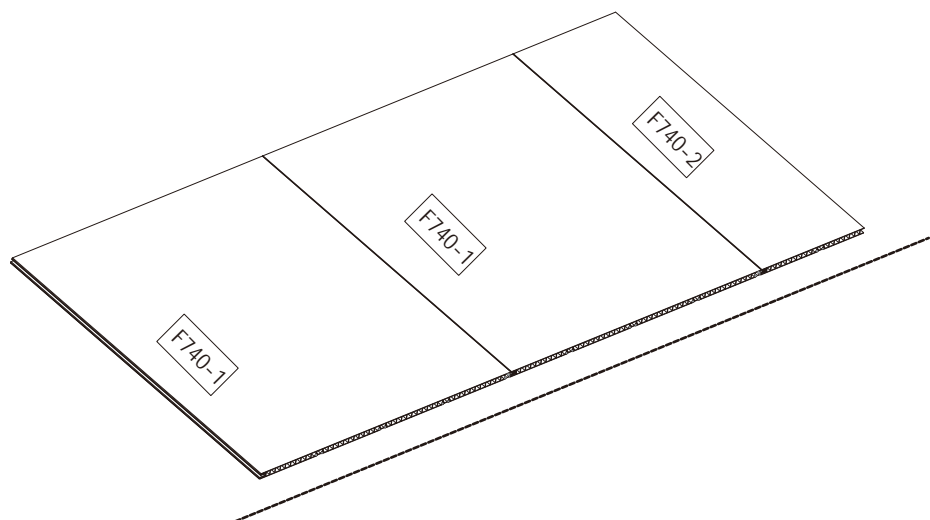
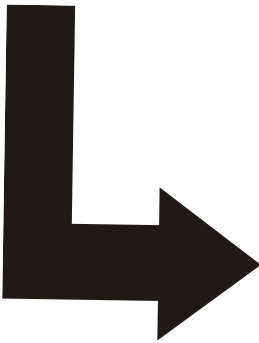
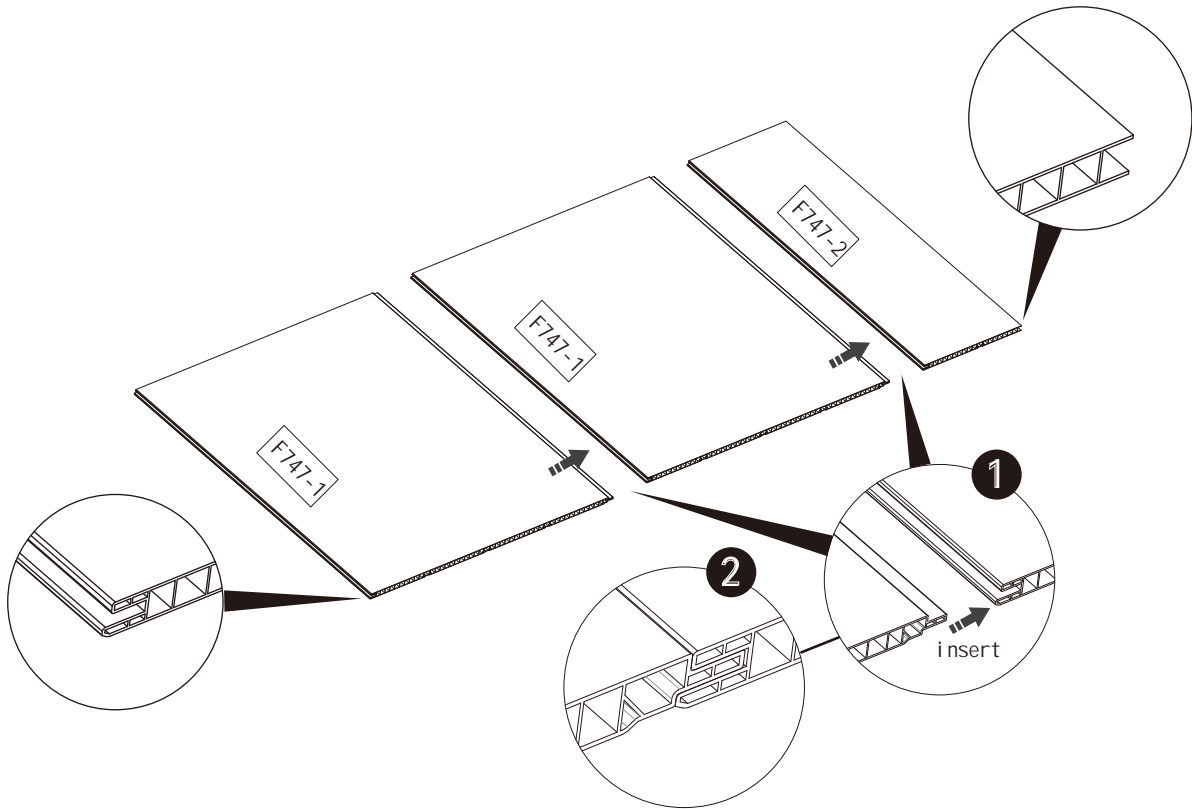
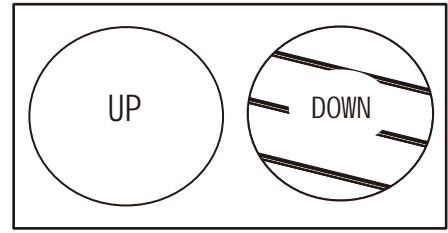
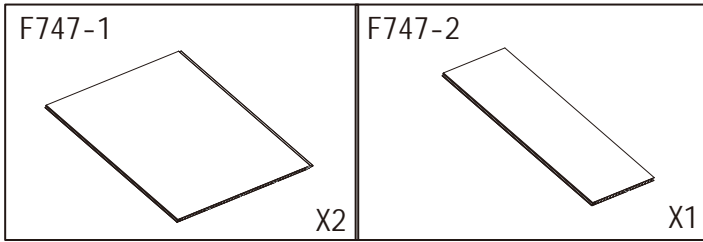

INSTALLATION STEPS

Note: floor panel could be connected via a insert way.

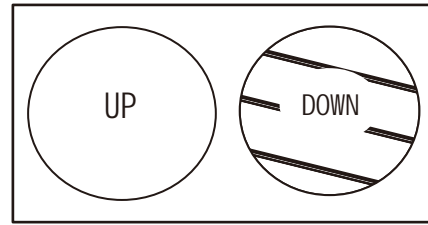
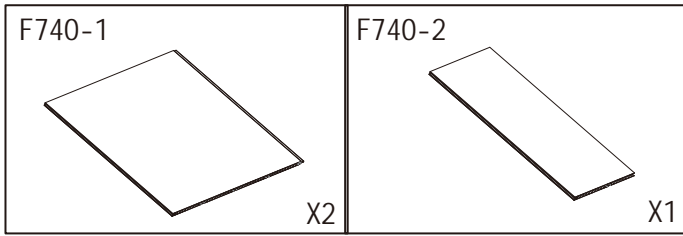

the grooved side facing down
and the flat side facing up.

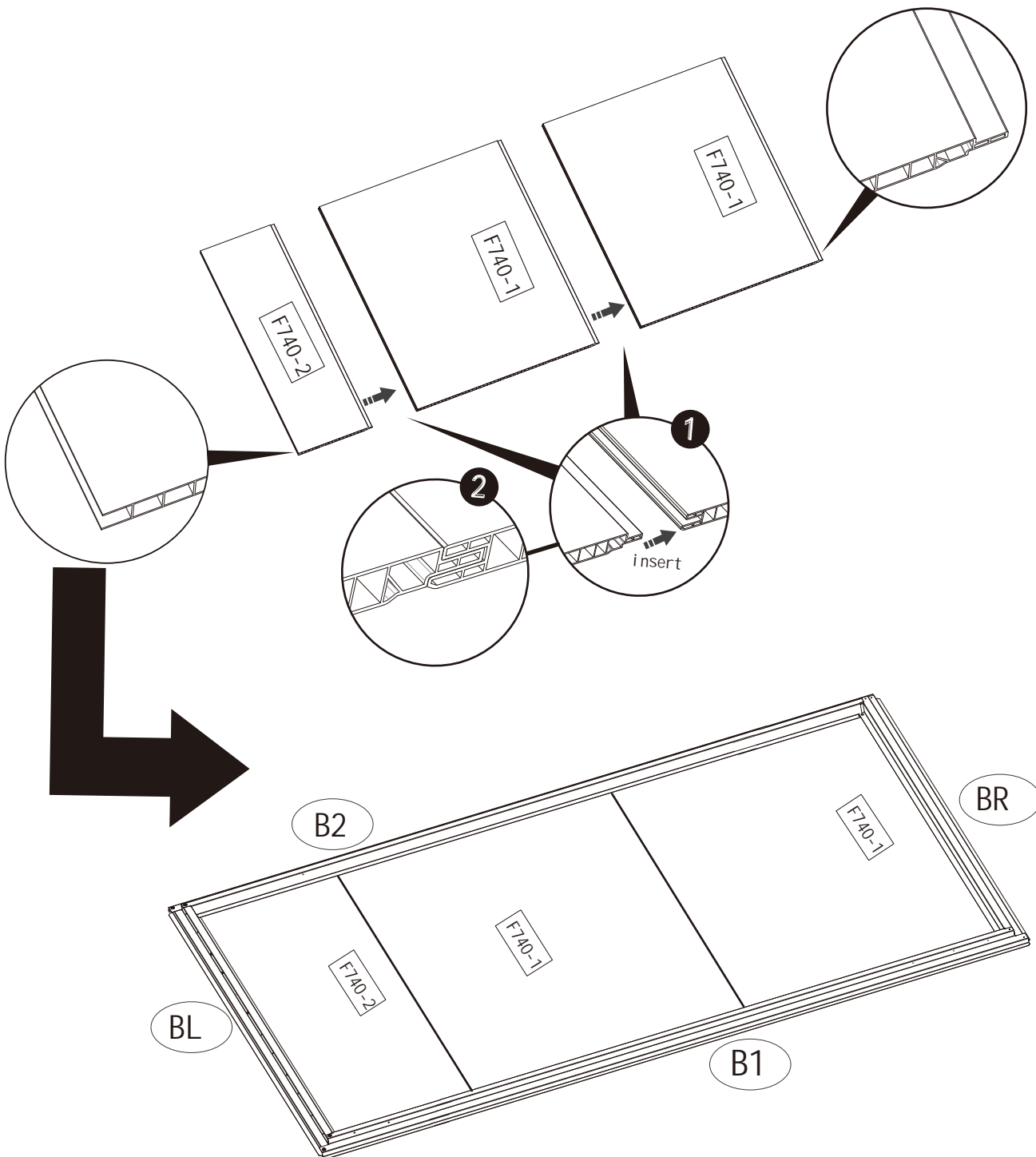

HELP CENTER

WE STAND BEHIND THE QUALITY OF OUR PRODUCT

1. If you have any other issues with your item(s), please feel free to contact us! We will always do our best to come up with a solution that you will be happy with.
2. Please get in touch with our customer service team before returning the item(s).
3. Please do not throw away the original box(es) if you have not finished assembling and confirmed no quality issues.

RETURN POLICY

Length of return period:

You can return the item(s) within 30 days of purchase.

In the meanwhile, everything you purchased from us comes with a one-year warranty.

Who is responsible for the return shipping fee:

We will cover the return shipping fees if:

1. Your item has a manufacturing defect in materials or workmanship. For example, material cracking or screw hole misalignment. We will send you a prepaid shipping label after you send us photos or videos of the defects.
2. Your item has been damaged in transit. For example, metal part is broken or product is damaged. We will send you a prepaid shipping label after you send us photos of the damage.
3. You receive the wrong box(es) due to a warehouse error, We will send you a prepaid shipping label after you send us photos of the item(s), shipping label(s) and words(SKU) on the outer box(es).

* However, we still hope to work with you for a better solution instead of a return. Please don't hesitate to contact our customer service team.

Customer will cover the return shipping fees if:

1. You don't like the item(s) after receiving the box(es).
2. You no longer need the item(s) but have received the box(es).
3. You buy the item(s) by mistake but have received the box(es).
4. Order/shipment cancellation failed, and you have received the box(es).

Return Request

In order to get a full refund as described in this return policy, all items must be:

1. In a brand new/unused condition. Please provide photos before and after packaging.
2. All accessories and parts must be firmly packed in all original packaging before returning. If your return does not meet these requirements, you may not receive a full refund.

When can I receive a refund?

After you return it using the prepaid shipping label we provided and inform us, the refund will be issued once the package(s) have been returned to our warehouse.

What can I do if the product is damaged after warranty?

We want you to be a happy customer. Please reach out to us via email or text, and we will work on a solution to ensure your satisfaction.

Question about your product? Please do not hesitate to email or text us. We will reply to you within 24-48 hours.



+1(503) 928-7812



hellovitesse@gmail.com

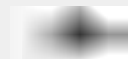

instagram: vitessegaming



youTube : vitessegaming

SAVE THESE INSTRUCTIONS