

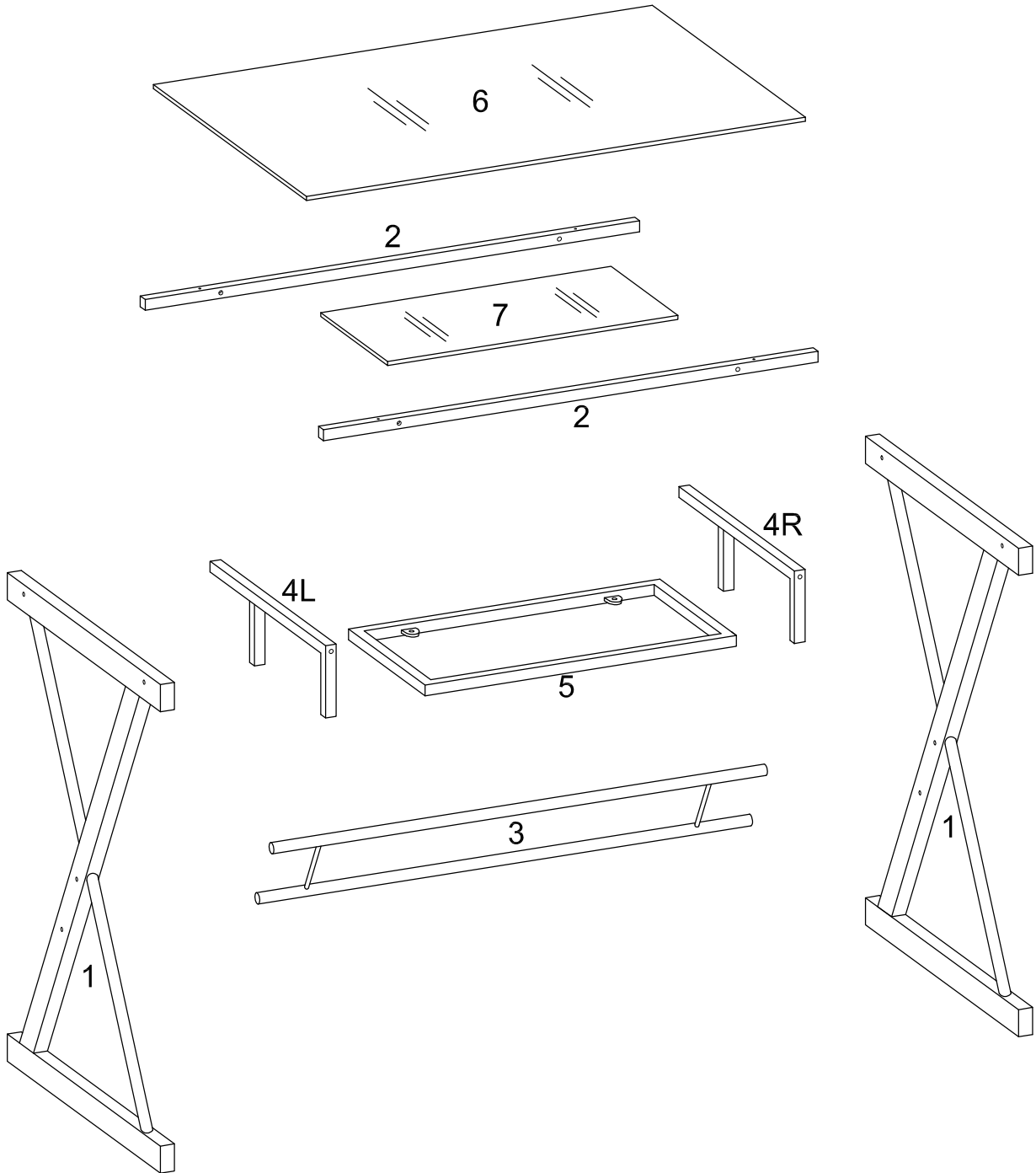



## Assembly Instructions





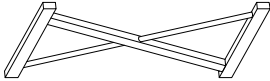

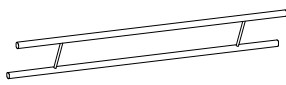
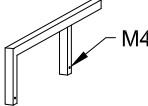
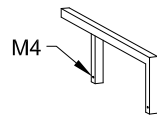
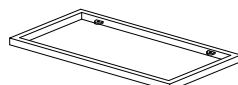
# Parts List



# Component List

1		Desk leg	2 pcs
2		Upper crossbar	2 pcs
3		Lower cross bar	1 pc
4L		Left keyboard tray supports	1 pc
4R		Right keyboard tray supports	1 pc
5		Keyboard tray frame	1 pc
6		Desk glass	1 pc
7		Keyboard tray glass	1 pc

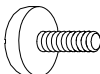
# Hardware List

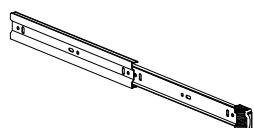
A			Wrench	1 pc
B		M4*10(mm)	Small screws	8 pcs
C		M6*45(mm)	Medium bolts	12 pcs
D			Desk feet	4 pcs
E			Rubber suction cups	8 pcs
F			Keyboard tray slider	2 pcs

*The hardware quantities listed above are required for proper assembly.  
Some extra hardware may also have been included.*

# Step 1

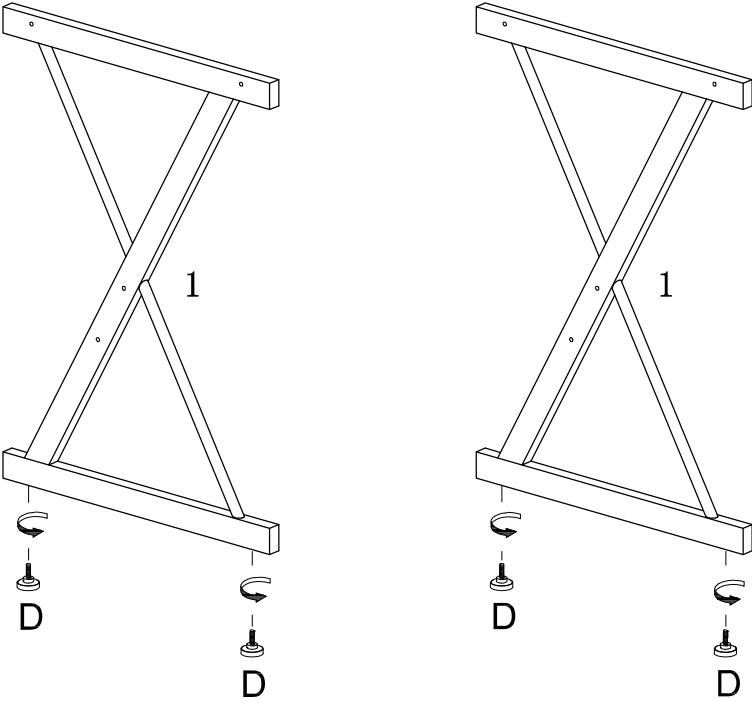

Screw desk feet (D) into desk legs (1).

# Step 2

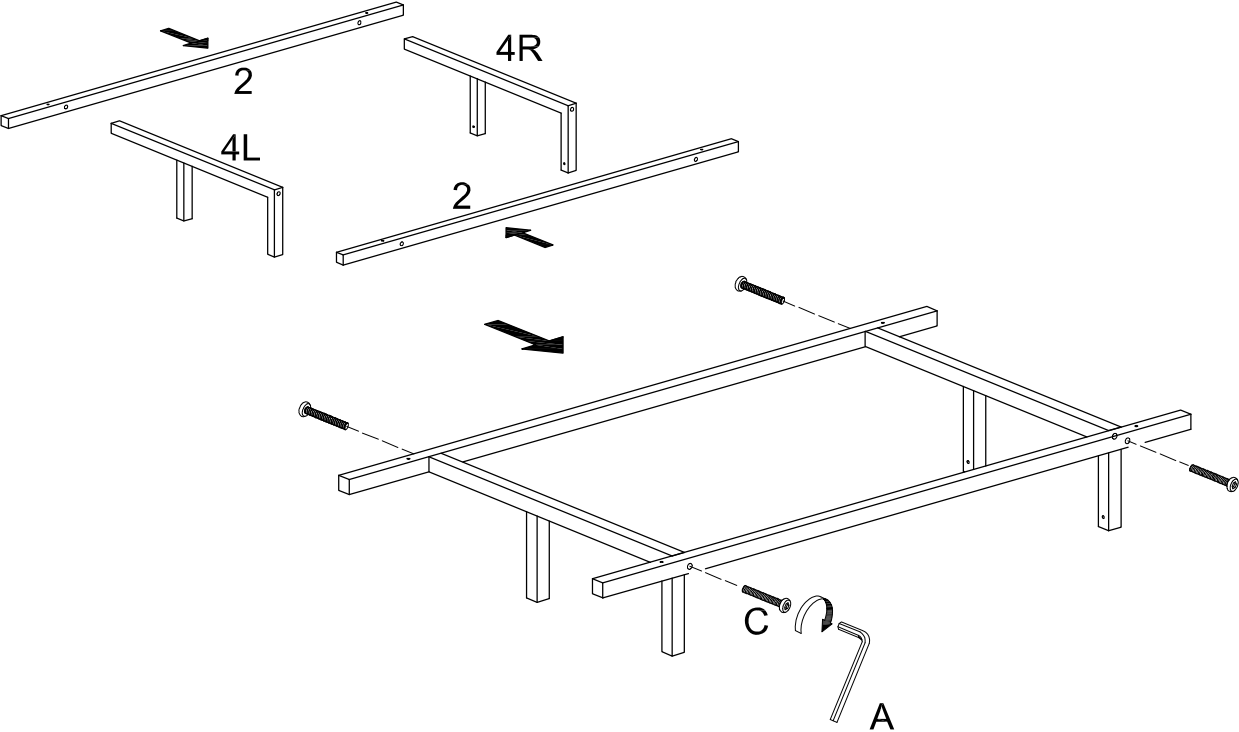

Attach upper crossbars (2) to keyboard tray supports (4L) and (4R) using large bolts (C) .  
Ensure that each keyboard tray support is on the correct side (i.e. right or left).

# Step 3

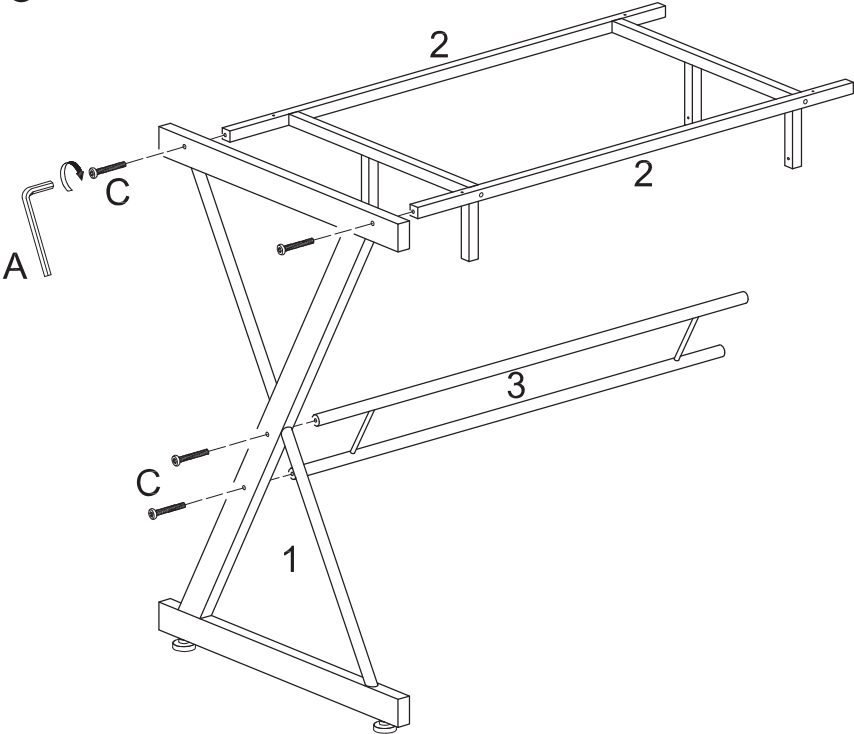

Attach the assembly from Step 2 and lower crossbar (3) to desk leg (1) using large bolts (C).

# Step 4

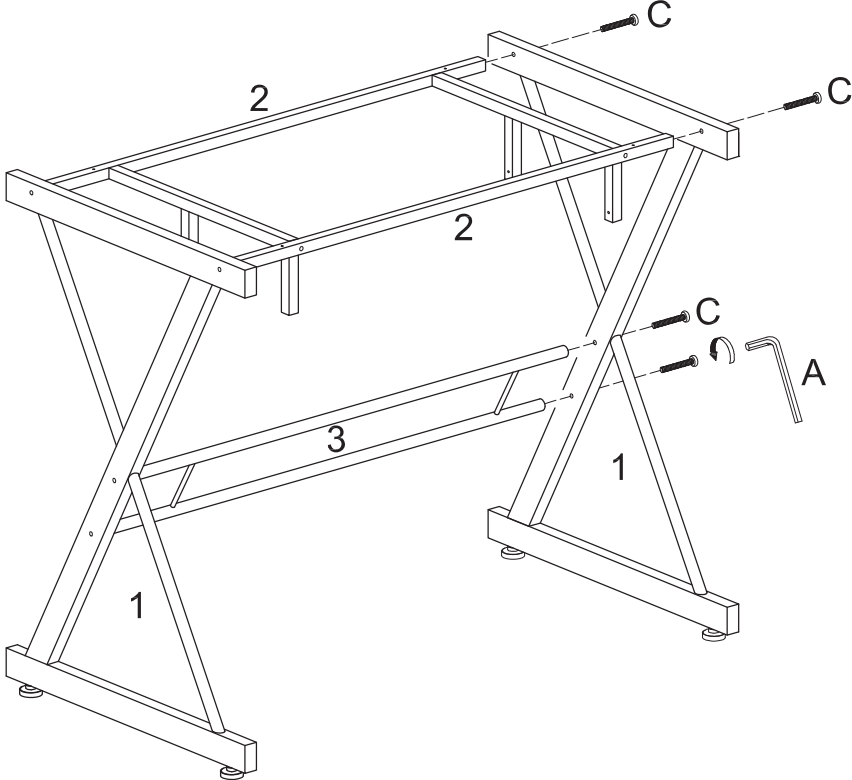

Attach desk leg (1) to the assembly from Step 3 using large bolts (C).

## Step 5

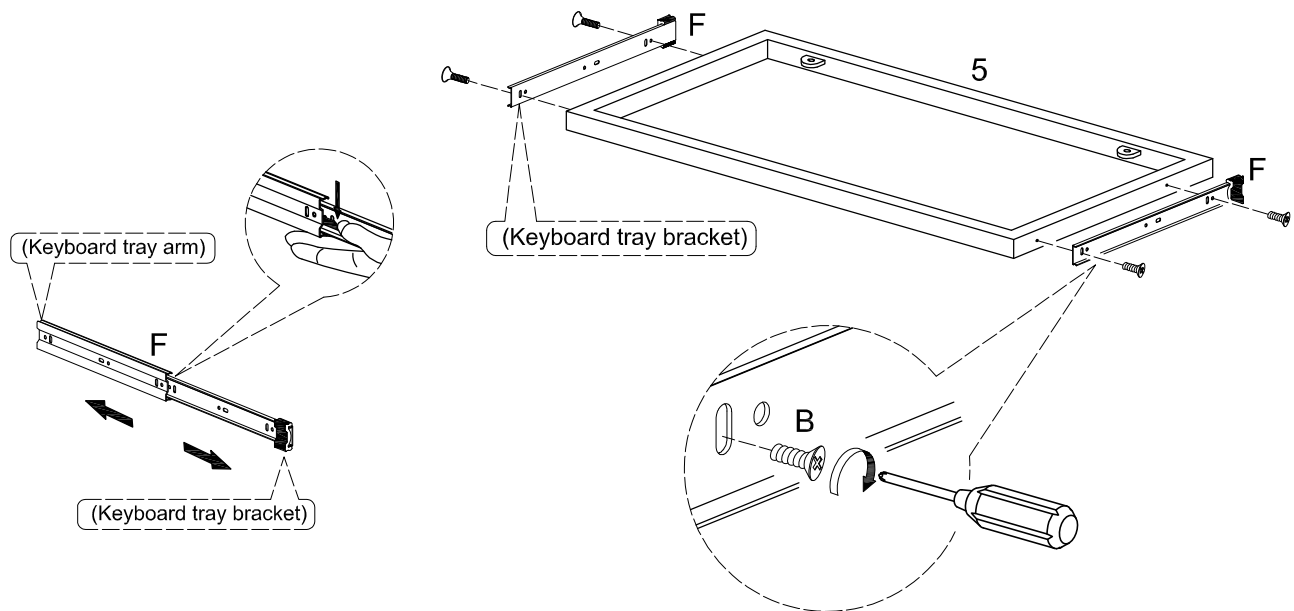

Disassemble keyboard tray slider (F) by first sliding the keyboard tray arm and the keyboard tray bracket apart. Depress the small lever on the keyboard tray bracket and gently pull the two pieces apart. Attach the keyboard tray brackets to keyboard tray frame (5) using small bolts (B).

## Step 6

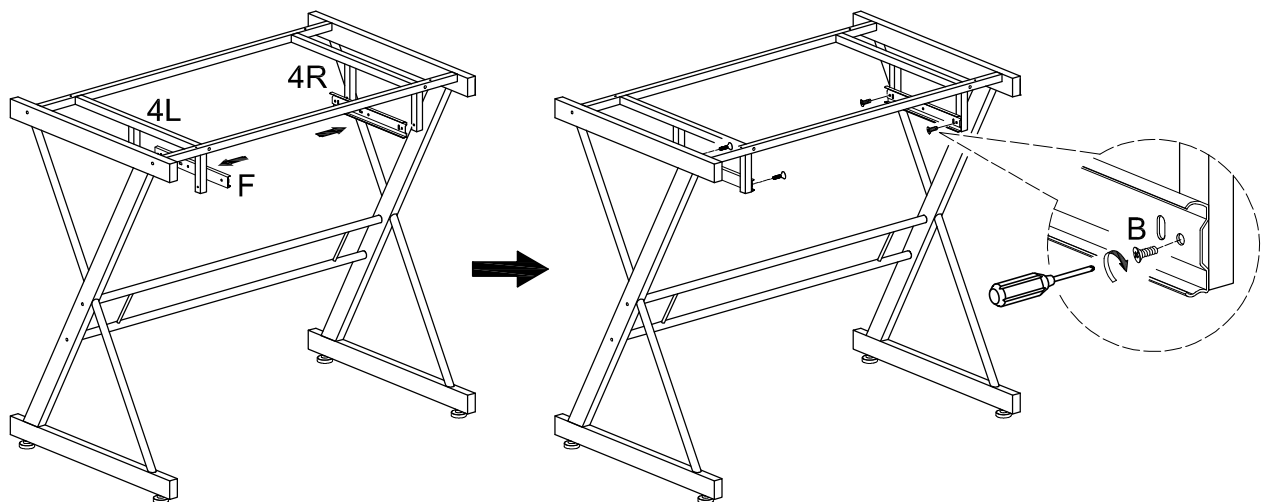

Attach the keyboard tray arms to keyboard tray support (4L) and (4R) using small bolts (B).  
Ensure that the open end of each keyboard tray arm is at the front of the desk.

## Step 7

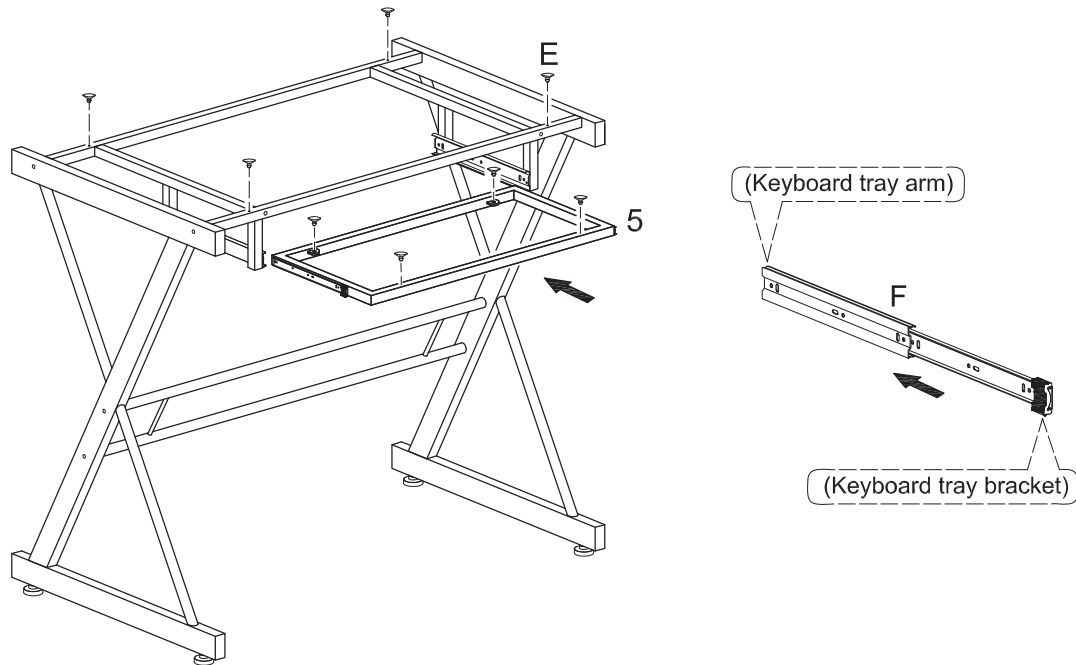

Attach rubber suction cups (E) to the desk frame in the designated locations. Carefully slide keyboard tray frame (7) with attached keyboard tray brackets into the keyboard tray arms.

## Step 8

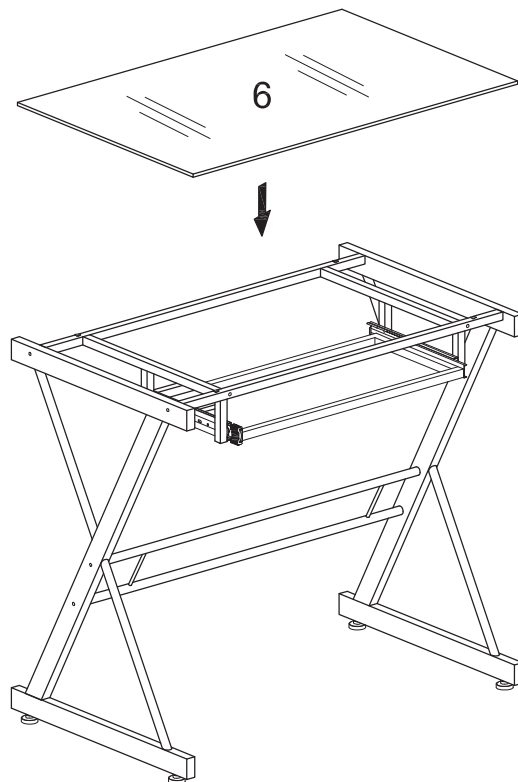

Carefully place desk glass (6) on the desk frame, pressing gently to secure the glass to the rubber suction cups.

## Step 9

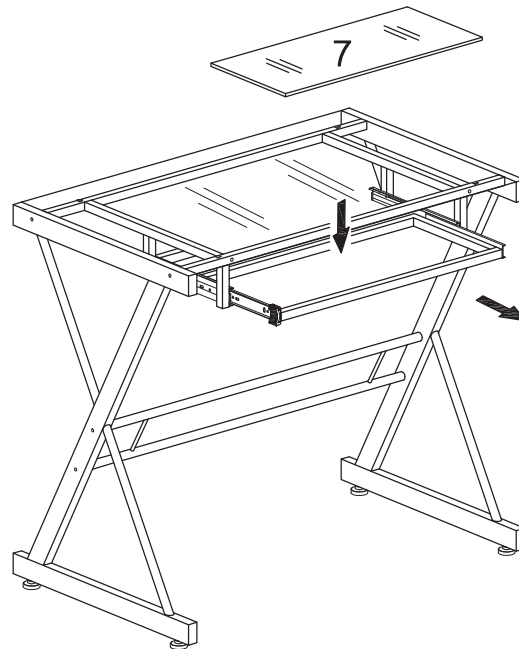

Slide the keyboard tray frame out and carefully place keyboard tray glass (7) on the keyboard tray frame. Press down gently to secure the glass to the rubber suction cups.

## Step 10

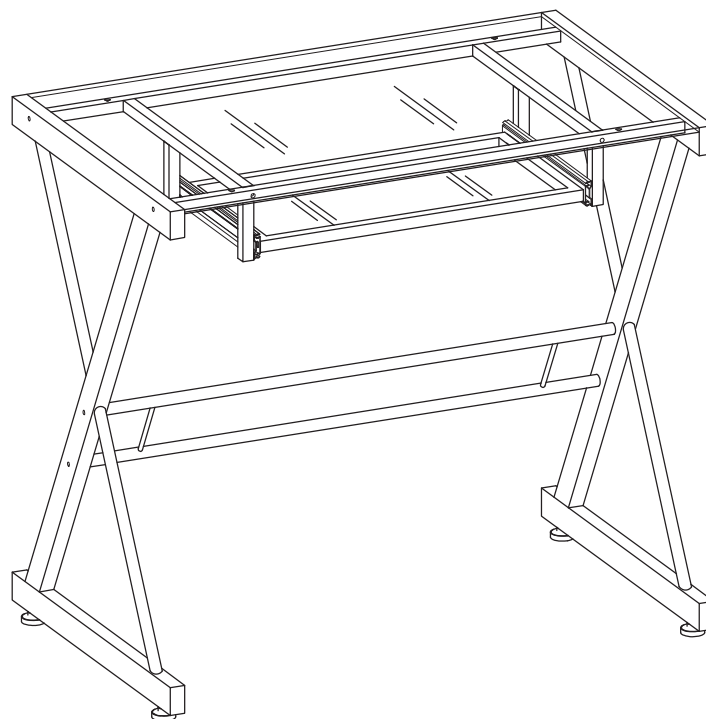

**Final Assembly**