

SECRET MAPLE & CHOCOLATE : ÉRABLE SECRET ET CHOCOLAT : ARCE SECRETO Y CHOCOLATE

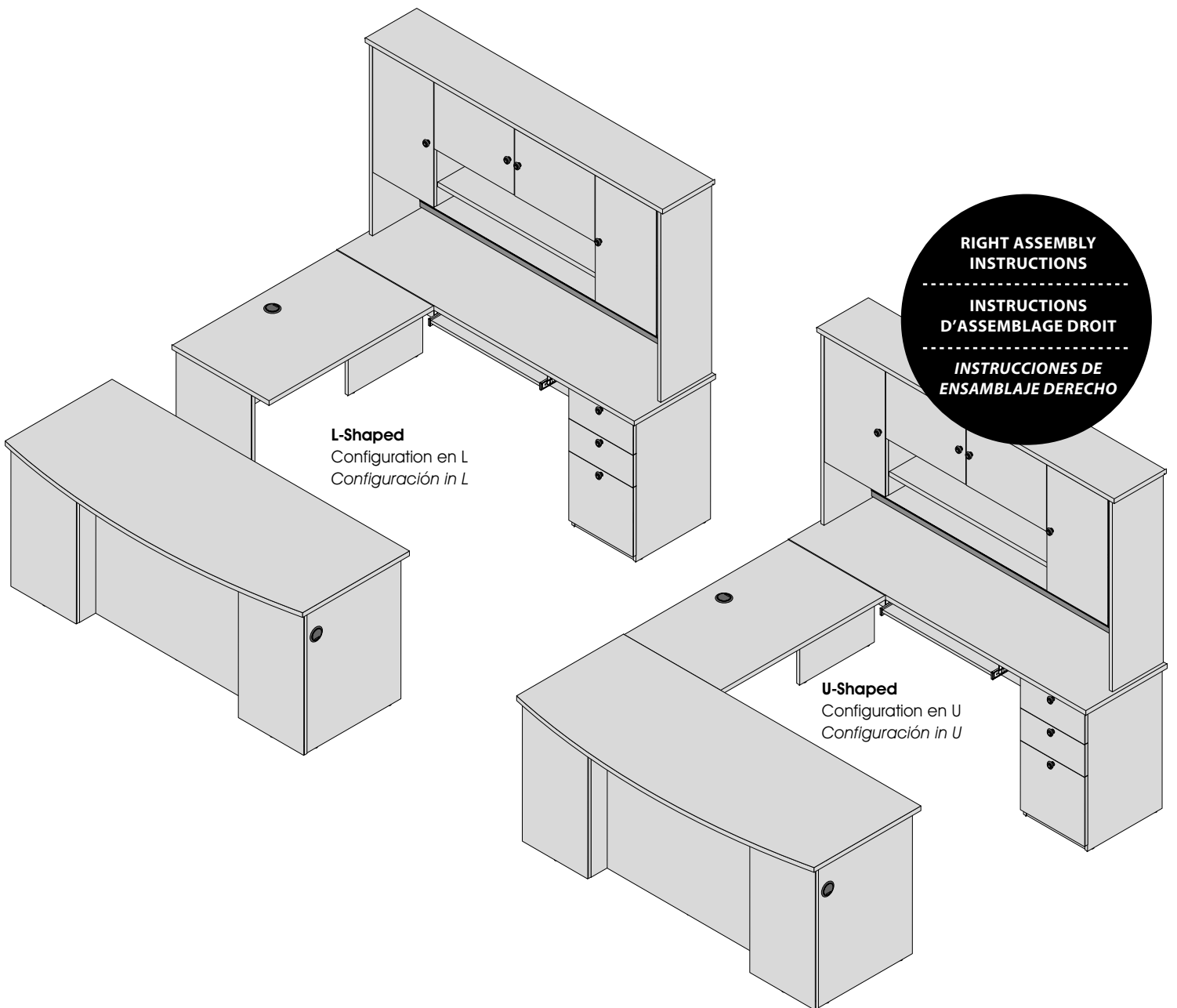

**L-Shaped**  
Configuration en L  
Configuración in L

**U-Shaped**  
Configuration en U  
Configuración in U

**RIGHT ASSEMBLY  
INSTRUCTIONS**  
-----  
**INSTRUCTIONS  
D'ASSEMBLAGE DROIT**  
-----  
**INSTRUCCIONES DE  
ENSAMBLAJE DERECHO**

## Thank you for choosing a product. Your total satisfaction is our #1 priority.

### Customer service and warranty information

Should you have a problem or need more information concerning the warranty, ***do not call to the place of purchase.***

**Please call our customer service department for immediate assistance using the following toll free number**

Please have your assembly instruction manual on hand when you call. Our products are warranted to the original purchaser against defects in material or workmanship in the furniture. Defects as mentioned in this warranty refer to any imperfections which may impair the use of the product. Our warranty is expressly limited to the replacement of furniture parts and components for ten years following the date of purchase. We will replace any part that is defective. This warranty applies under conditions of normal use. Our furniture products are not intended for outdoor use. The warranty does not cover defects caused by improper assembly or disassembly, defects occurring after purchase due to product modifications, intentional damage, accident, misuse, exposure to the elements and labor or assembly costs. We reserve the right to request proof of purchase to document a warranty claim. In no event shall we be liable for incidental or consequent damages resulting from the misuse of the product. This warranty is not transferable and is valid only in Canada and the United States excluding Alaska, Hawaii and Puerto Rico.

PROBLEMS  
OR INFORMATION

-----  
POUR TOUT PROBLÈME  
OU INFORMATION  
-----







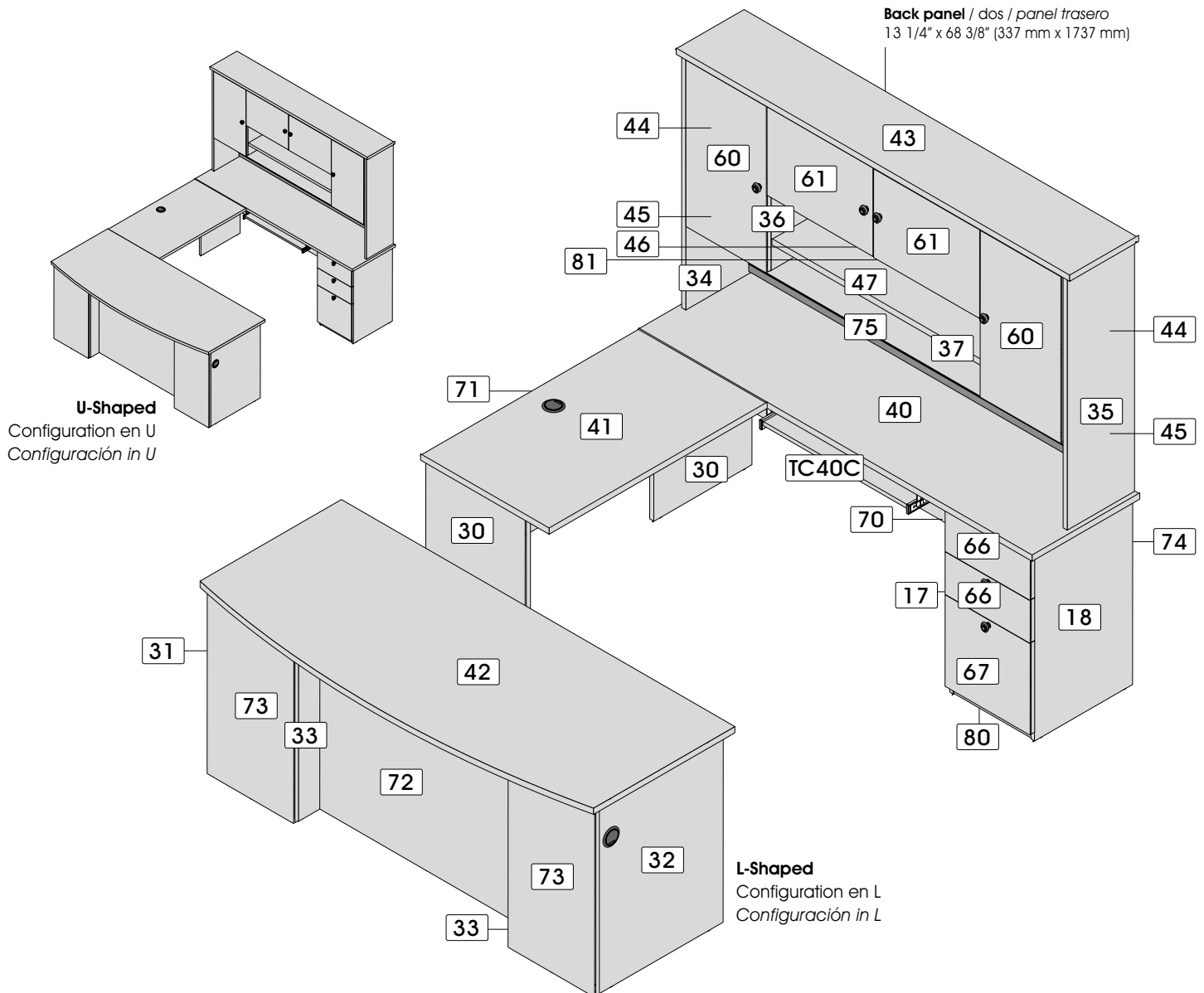











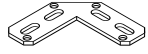
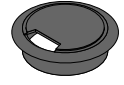

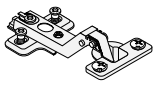
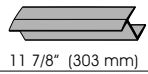
PROBLEMA O  
INFORMACION

**PARTS / PIÈCES / PIEZAS**

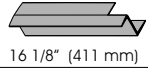
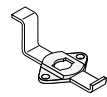
CODE / CÓDIGO	QTY / QTÉ / CANT.	CODE / CÓDIGO	QTY / QTÉ / CANT.	CODE / CÓDIGO	QTY / QTÉ / CANT.	CODE / CÓDIGO	QTY / QTÉ / CANT.
CA01A	4	33	2	45	2	73	2
CA05A	4	34	1	46	1	74	1
CA09A	2	35	1	47	1	75	1
CA13A	2	36	1	60	2	80	1
TC40C	1	37	1	61	2	81	1
17	1	40	1	66	2	<b>Back panel / dos / panel trasero</b> 13 1/4" x 68 3/8" (337 mm x 1737 mm)	1
18	1	41	1	67	1	<b>Bottom / fond / fondo</b> 12 7/16" x 15 3/8" (316 mm x 391 mm)	1
30	2	42	1	70	1		
31	1	43	1	71	1		
32	1	44	2	72	1		

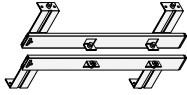
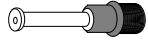
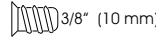

**HARDWARES / QUINCAILLERIES / QUINCALLAS**

CODE / CÓDIGO	QTY / QTÉ / CANT.	CODE / CÓDIGO	QTY / QTÉ / CANT.	CODE / CÓDIGO	QTY / QTÉ / CANT.	CODE / CÓDIGO	QTY / QTÉ / CANT.
AM-182  1/16" (2 mm)	4	CR-141 	2	PA-844  1" (25 mm)	15	VF-232  7/8" (22 mm)	7
CA-77 	6	EC-744 	6	PF-106 	1	VM-601  3/4" (20 mm)	6
CA-99 	52	EQ-143 	4	PF-108 	3	VR-207  1/2" (13 mm)	24
CH-840 	8	EX-681  11 7/8" (303 mm)	2	PO-777 	7	VR-212  1" (25 mm)	44
CL-140 	-	EX-702  16 1/8" (411 mm)	2	SE-686 	1		
CL-745 	1	EX-766 	1	Tl-365 	4		
CO-249 <b>runners 406 mm (16")</b> coulisseaux 406 mm correderas 406 mm	3	H-03 	76	Tl-552 	5		
CO-843 	1	H-36 	74	VE-244  3/8" (10 mm)	18		

**REAL SIZE / GRANDEUR RÉELLE / TAMAÑO REAL**

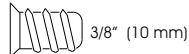
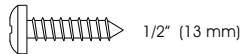
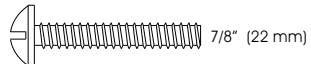
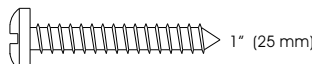
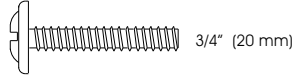
CODE / CÓDIGO	QTY / QTÉ / CANT.	CODE / CÓDIGO	QTY / QTÉ / CANT.
VE-244  3/8" (10 mm)	18	VR-207  1/2" (13 mm)	24
VF-232  7/8" (22 mm)	7	VR-212  1" (25 mm)	44
VM-601  3/4" (20 mm)	6		

**tools required**  
outils requis  
herramientas necesarias

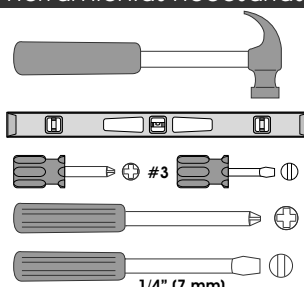

1/4" (7 mm)

**the use of electric tools must be made with vigilance.**  
l'utilisation d'outils électriques doit être faite avec vigilance.  
las herramientas eléctricas deben utilizarse con sumo cuidado.



**two people are required to assemble and move this model.**  
deux personnes sont requises pour assembler et déplacer ce modèle.  
se necesitan dos personas para ensamblar y desplazar este mueble.



# ▶ IMPORTANT NOTICE / NOTE IMPORTANTE / NOTA IMPORTANTE

Duly complete the self-adhesive sticker. / Assurez-vous de bien remplir l'auto-collant. / Asegúrese de completar correctamente la etiqueta.

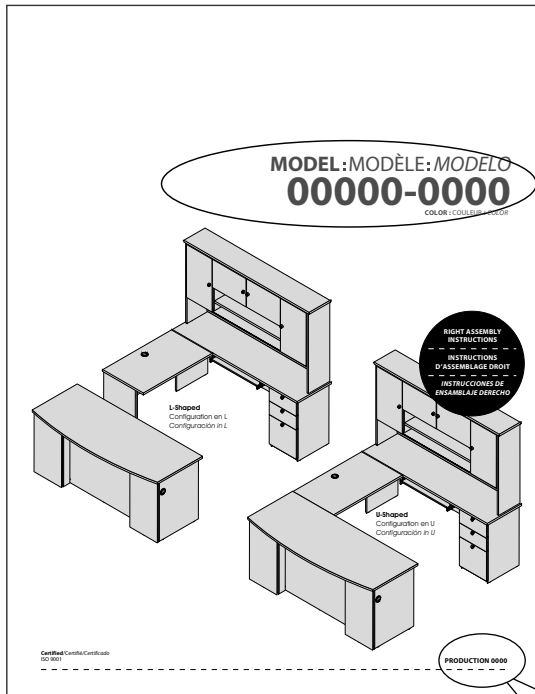

**PRODUCTION 0000**

**To better serve you!**  
Pour mieux vous servir!

→ **Model / Modèle:** \_\_\_\_\_

→ **Production Number**  
Numéro de production: \_\_\_\_\_

**Important/Importante**

**Please retain the self-adhesive sticker which you will install at page 30 of the instruction manual.**

Conservez l'autocollant qui sera collé seulement à la page 30 du feuillet d'instructions.

Conserve la etiqueta que será pegada sólo en la página 30 de la hoja de instrucciones.

# ▶ IMPORTANT NOTICE / NOTE IMPORTANTE / NOTA IMPORTANTE

▶ **Main hardware system / Système de quincaillerie principal / Sistema principal de quincalla**

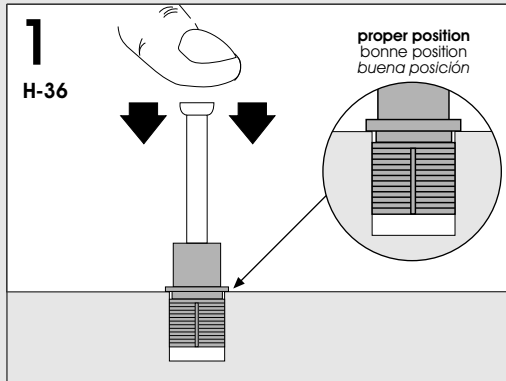

**If needed / En cas de nécessité**  
En caso de necesidad

**How to remove a misplaced assembly bolt (H-36).**  
Comment retirer un boulon (H-36) mal situé.  
Cómo retirar un perno (H-36) mal ubicado.

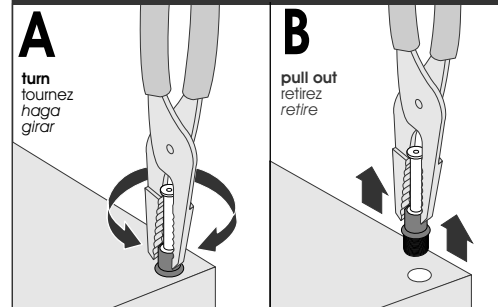

# 1 HARDWARE INSTALLATION / INSTALLATION DES QUINCAILLERIES / INSTALACIÓN DE LAS QUINCALLAS

Credenza / Crédence / Credencia

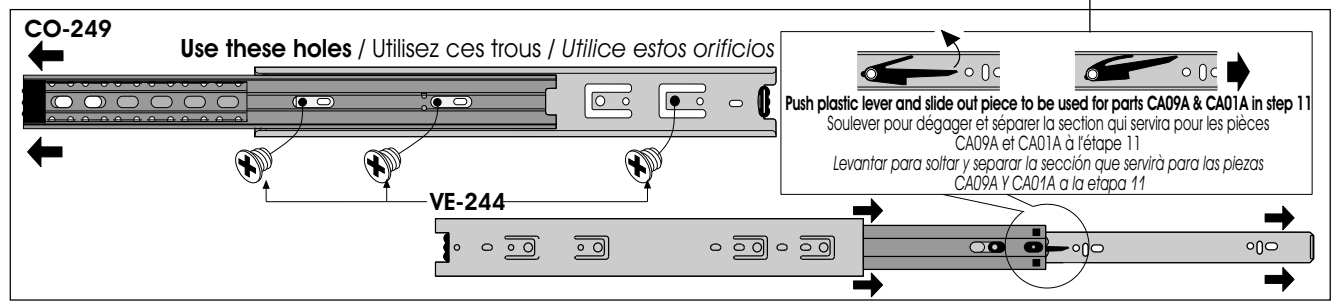
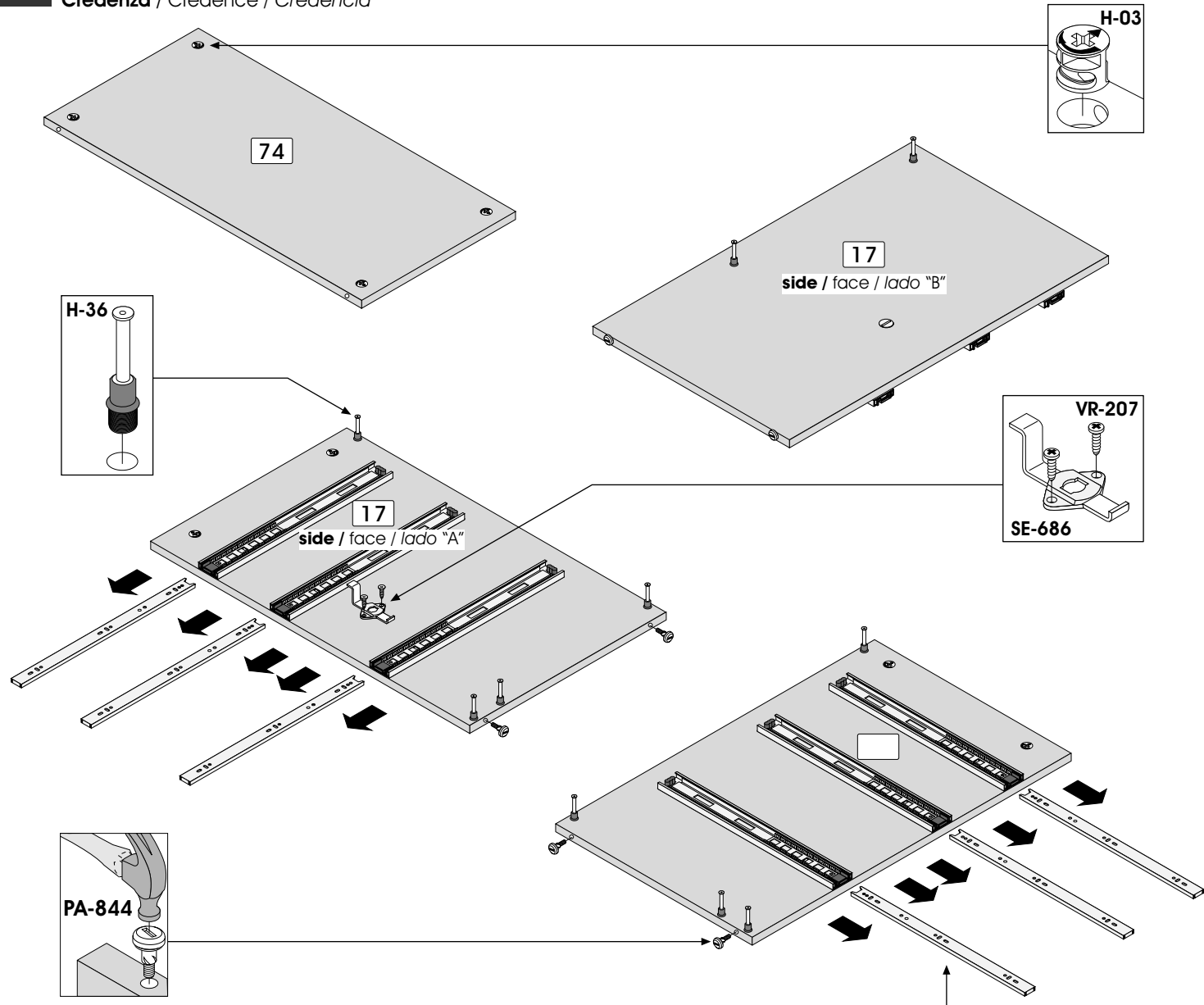

<b>Code / Código</b>	CO-249	H-03	H-36	PA-844	SE-686	VR-207	VE-244
<b>Qty / Qté / Cant.</b>	x 3	x 8	x 10	x 4	x 1	x 2	x 18

# 2 HARDWARE INSTALLATION / INSTALLATION DES QUINCAILLERIES / INSTALACIÓN DE LAS QUINCALLAS

Credenza / Crédence / Credencia

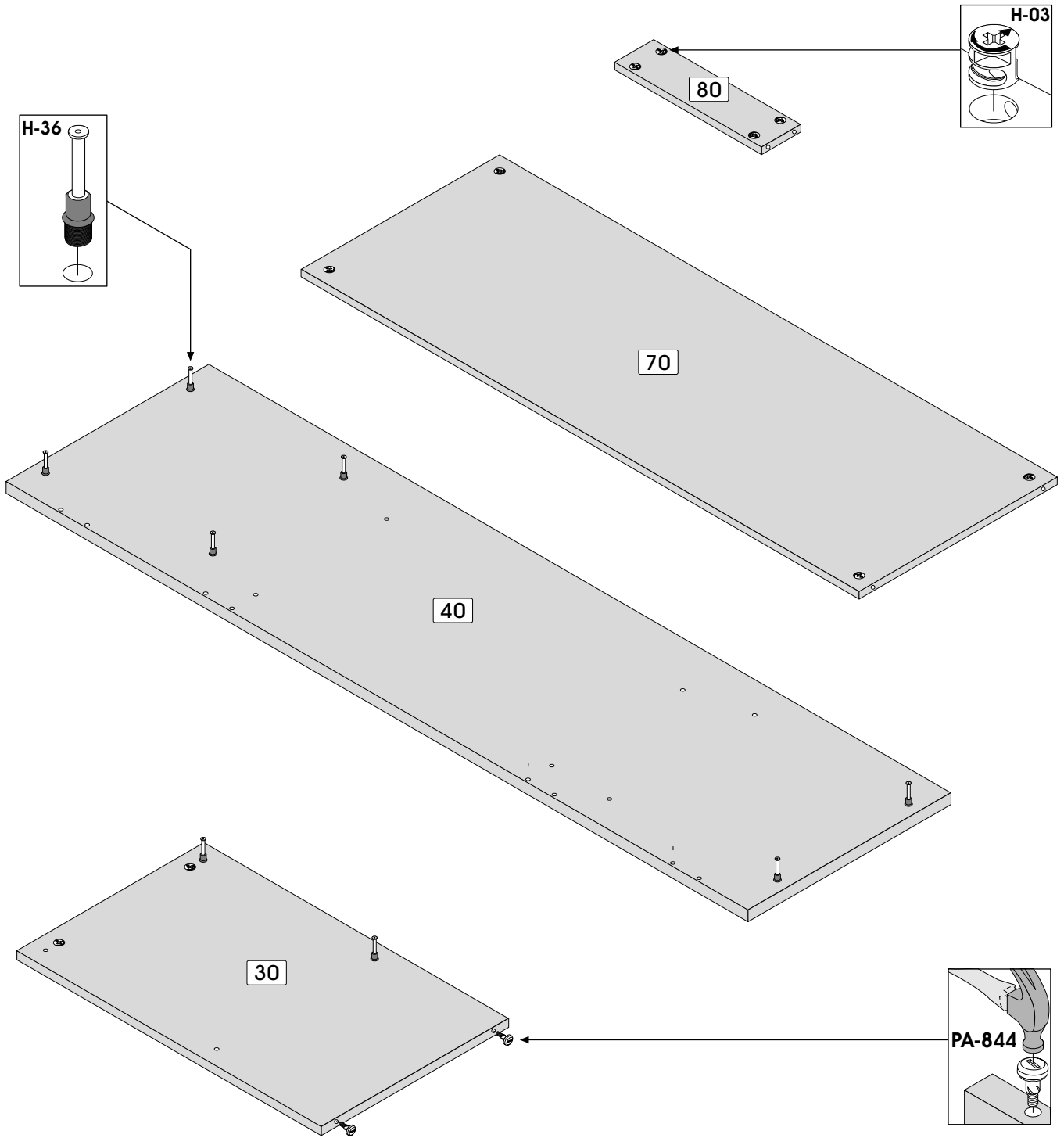

2

Code / Código

H-03

H-36

PA-844

Qty / Qté / Cant.

x 10

x 8

x 2

## IMPORTANT NOTICE / NOTE IMPORTANTE / NOTA IMPORTANTE

► **Main hardware system / Système de quincaillerie principal / Sistema principal de quincalla**

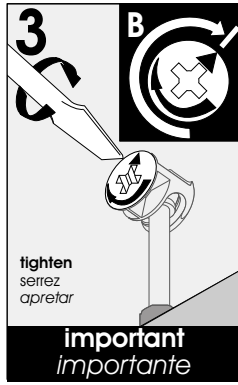
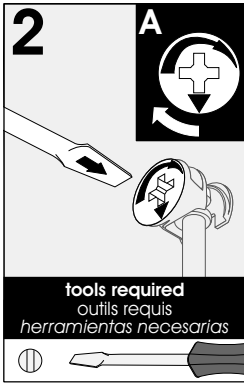
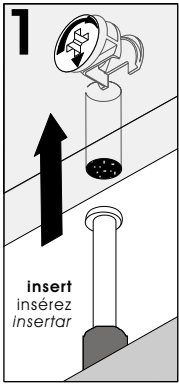

**Make sure to properly tighten each cam to ensure furniture solidity. Otherwise, parts could be damaged or the user could be injured.**

Assurez-vous de bien resserrer chaque rondelle pour assurer la solidité du meuble. Dans le cas contraire, des pièces pourraient être endommagées ou l'utilisateur pourrait se blesser.

Asegúrese de apretar bien cada arandela para garantizar la solidez del mueble. De lo contrario, podría provocarse daño a las piezas o las personas.

## 3 ASSEMBLY / ASSEMBLAGE / ENSAMBLAJE

**Credenza / Crédence / Credencia**

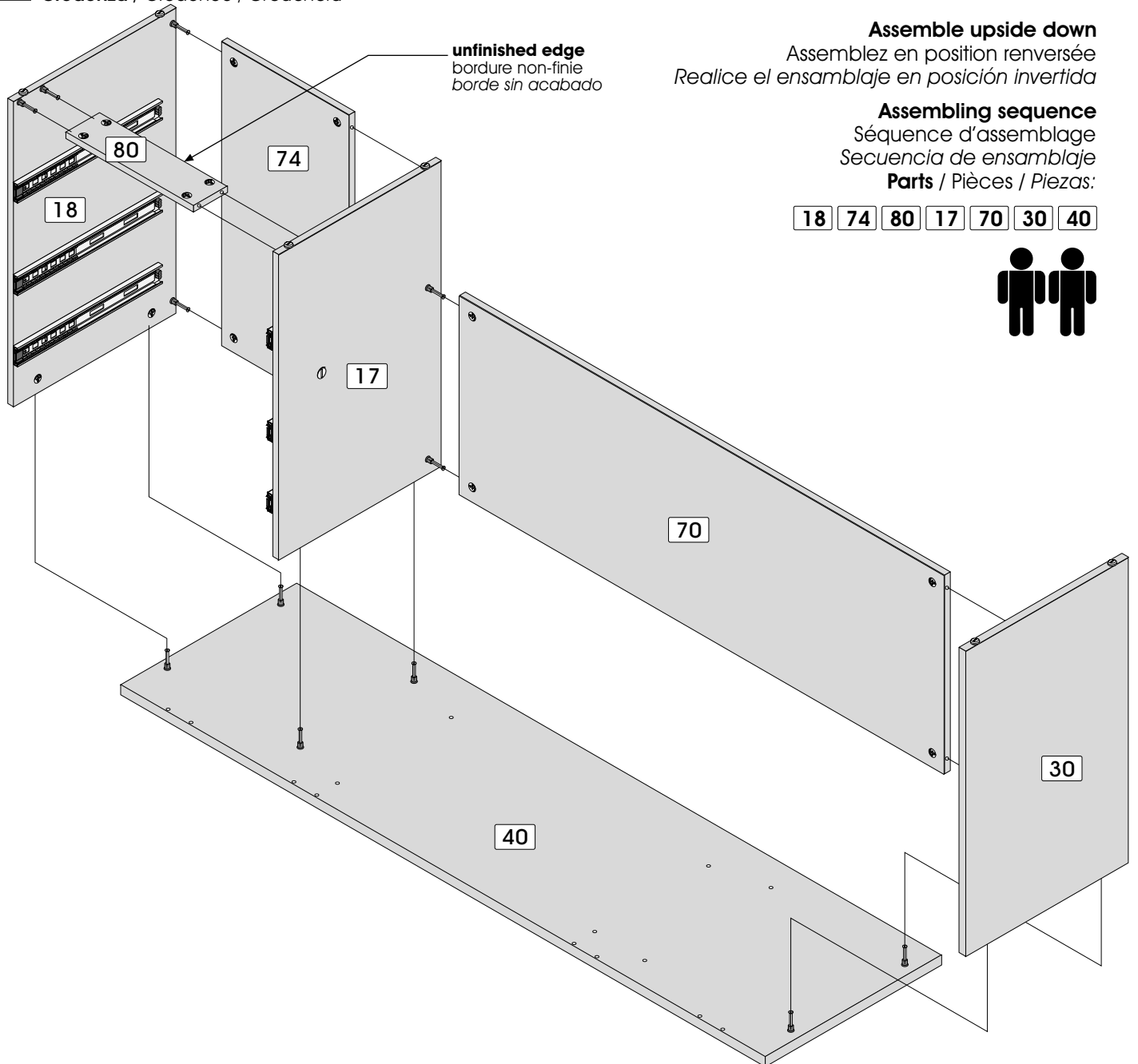

**Hutch / Étagère / Estantería**

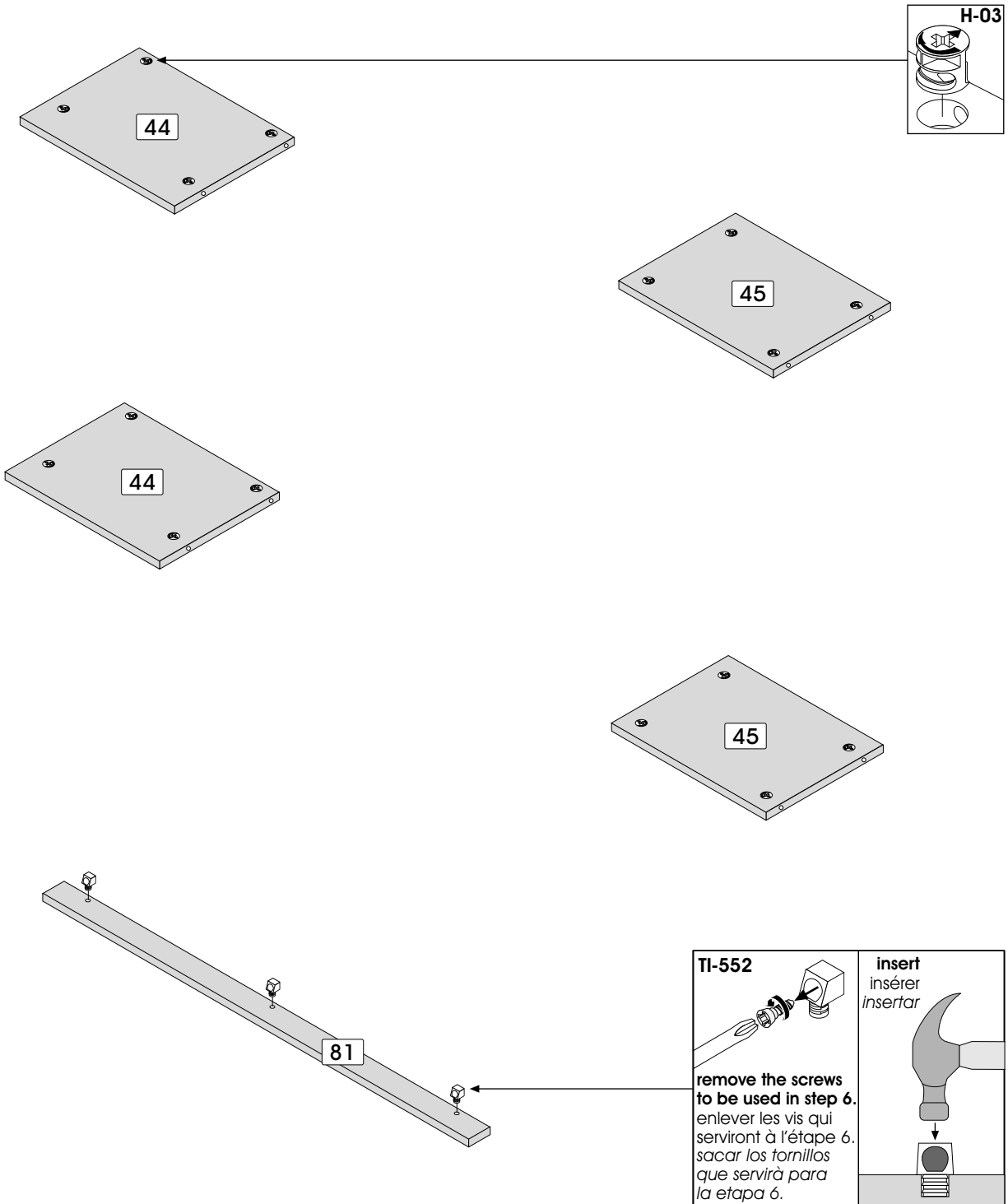

**4**

**Code / Código**

H-03

TI-552

**Qty / Qté / Cant.**

x 16

x 3

# 5

## HARDWARE INSTALLATION / INSTALLATION DES QUINCAILLERIES / INSTALACIÓN DE LAS QUINCALLAS

### Hutch / Étagère / Estantería

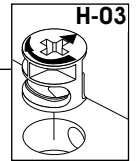

H-03

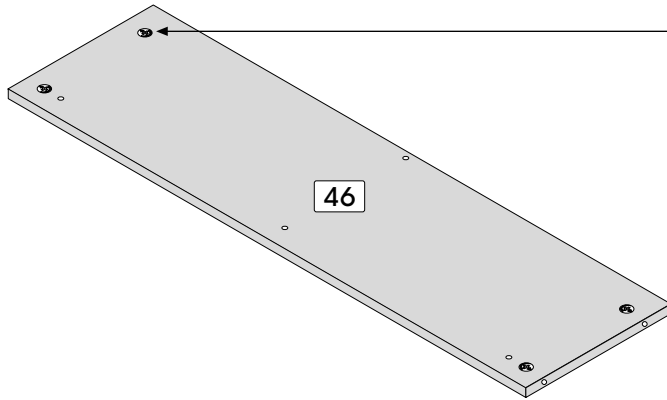

46

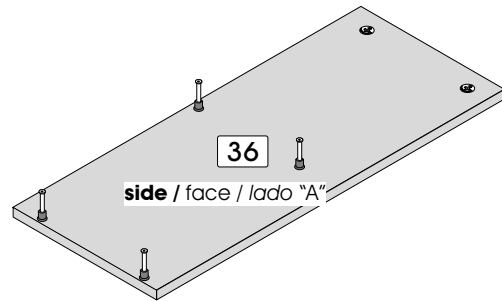

36

side / face / lado "A"

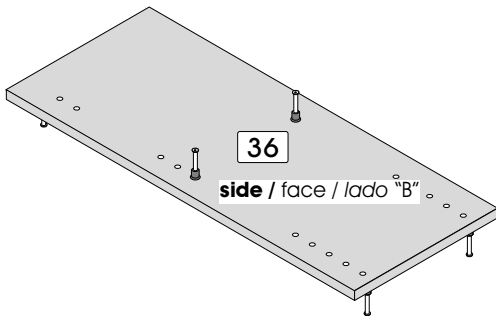

36

side / face / lado "B"

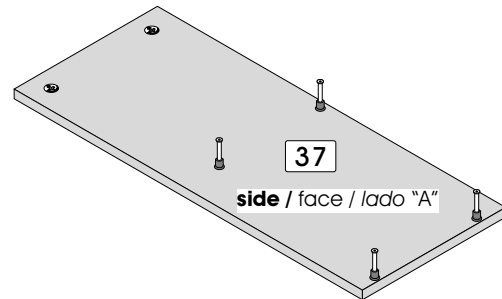

37

side / face / lado "A"

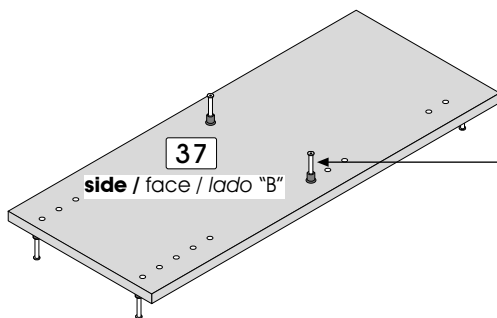

37

side / face / lado "B"

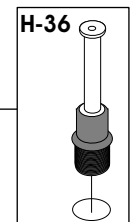

H-36

# 5



H-03



H-36

Code / Código

Qty / Qté / Cant.

x 8

x 12

**Assemble on the front edge**

Assemblez sur la bordure avant

Realice el ensamblaje sobre el borde delantero

**Assembling sequence**

Séquence d'assemblage

Secuencia de ensamblaje

Parts / Pièces / Piezas:

46 37 36 44 44 45 45 81

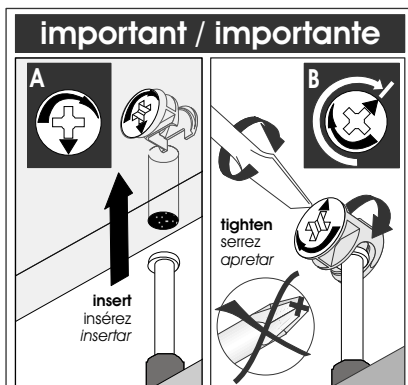
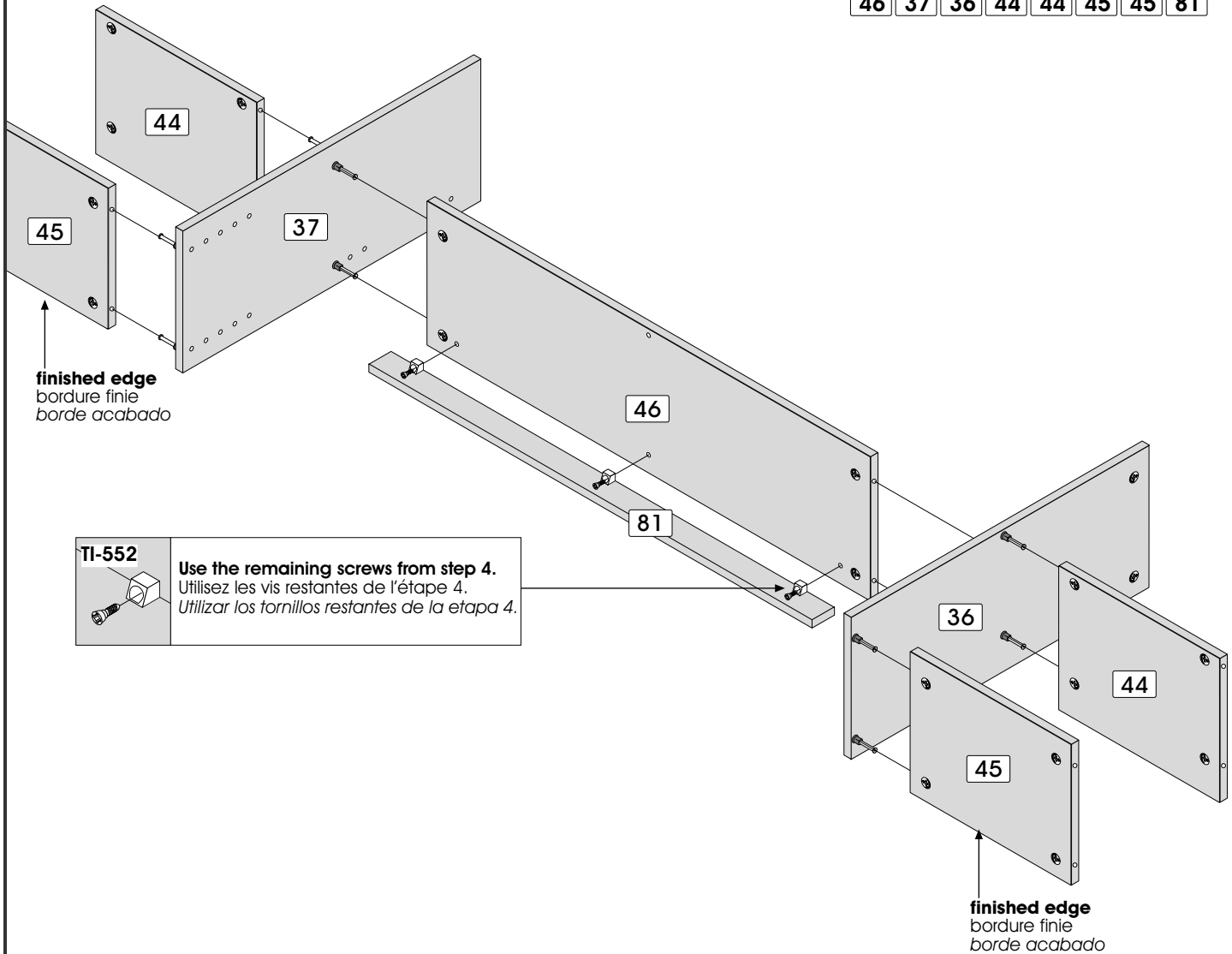

# 7 HARDWARE INSTALLATION / INSTALLATION DES QUINCAILLERIES / INSTALACIÓN DE LAS QUINCALLAS

Hutch / Étagère / Estantería

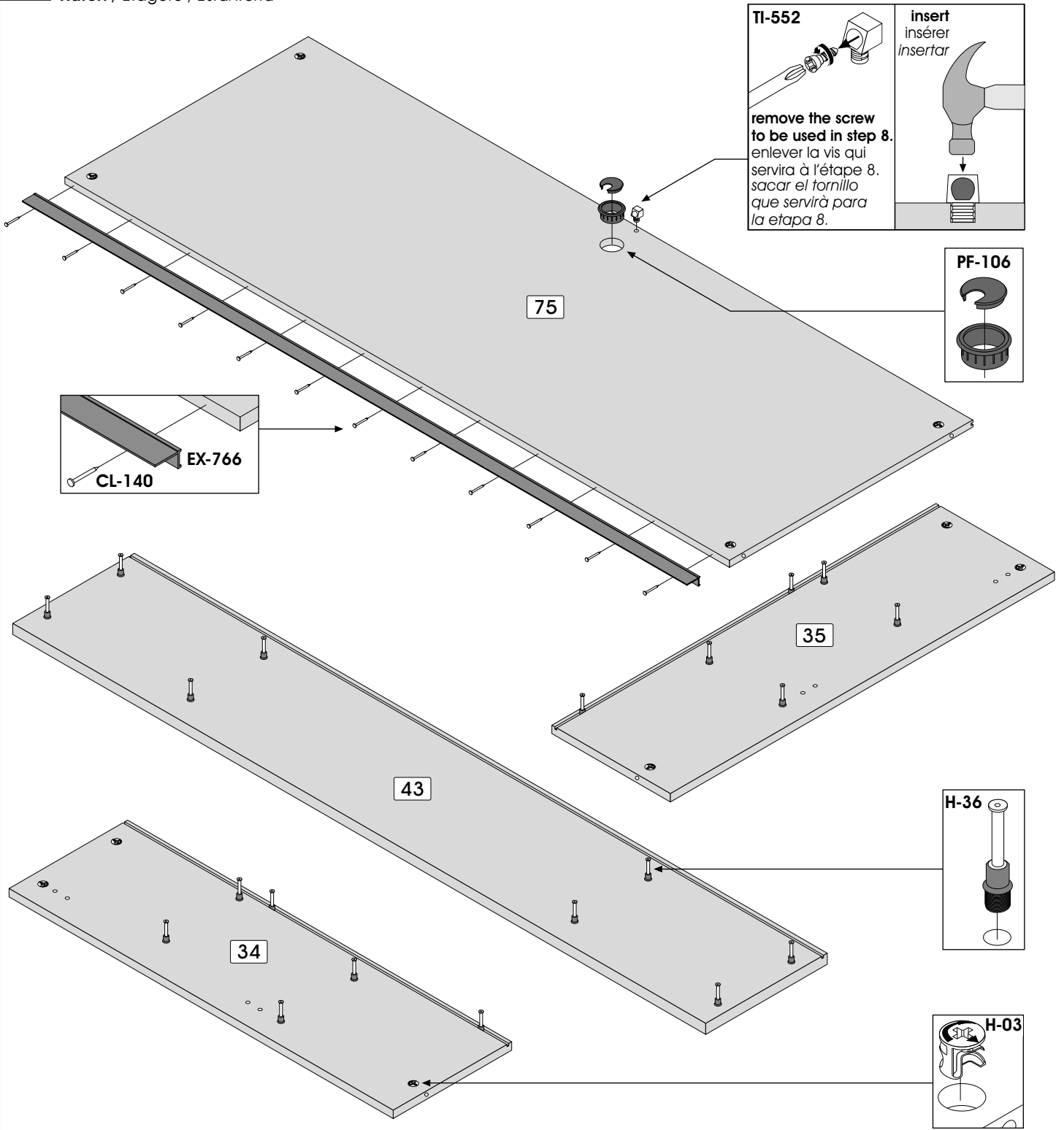

Code / Código	H-03	H-36	TI-552	PF-106	EX-766	CL-140
Qty / Qté / Cant.	x 10	x 20	x 1	x 1	x 1	-

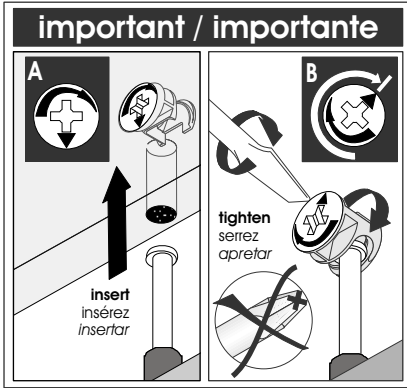

**Assemble on the back edge**  
 Assemblez sur la bordure arrière  
 Realice el ensamblaje sobre el borde trasero

**Assembling sequence**  
 Séquence d'assemblage  
 Secuencia de ensamblaje  
**Parts / Pièces / Piezas:**

75 34 + 44 45 36 36 45 44  
 + 35 + back panel / dos / panel trasero + 43

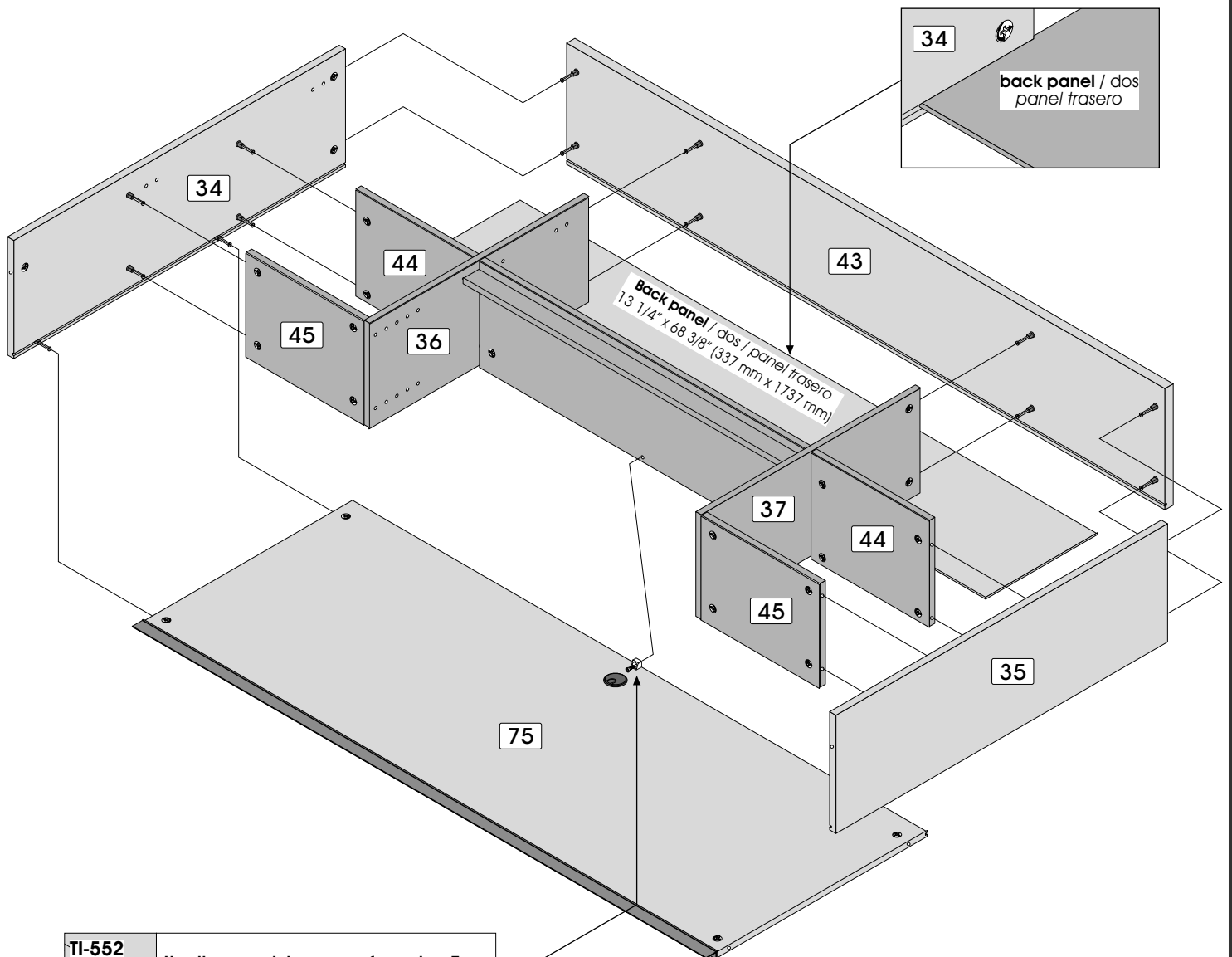

TI-552



Use the remaining screw from step 7.  
 Utilisez la vis restante de l'étape 7.  
 Utilizar el tornillo restante de la etapa 7.

**Assembling sequence**  
 Séquence d'assemblage  
 Secuencia de ensamblaje  
**Parts / Pièces / Piezas:**

40 + 34 35

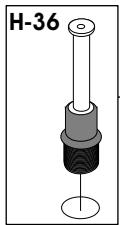
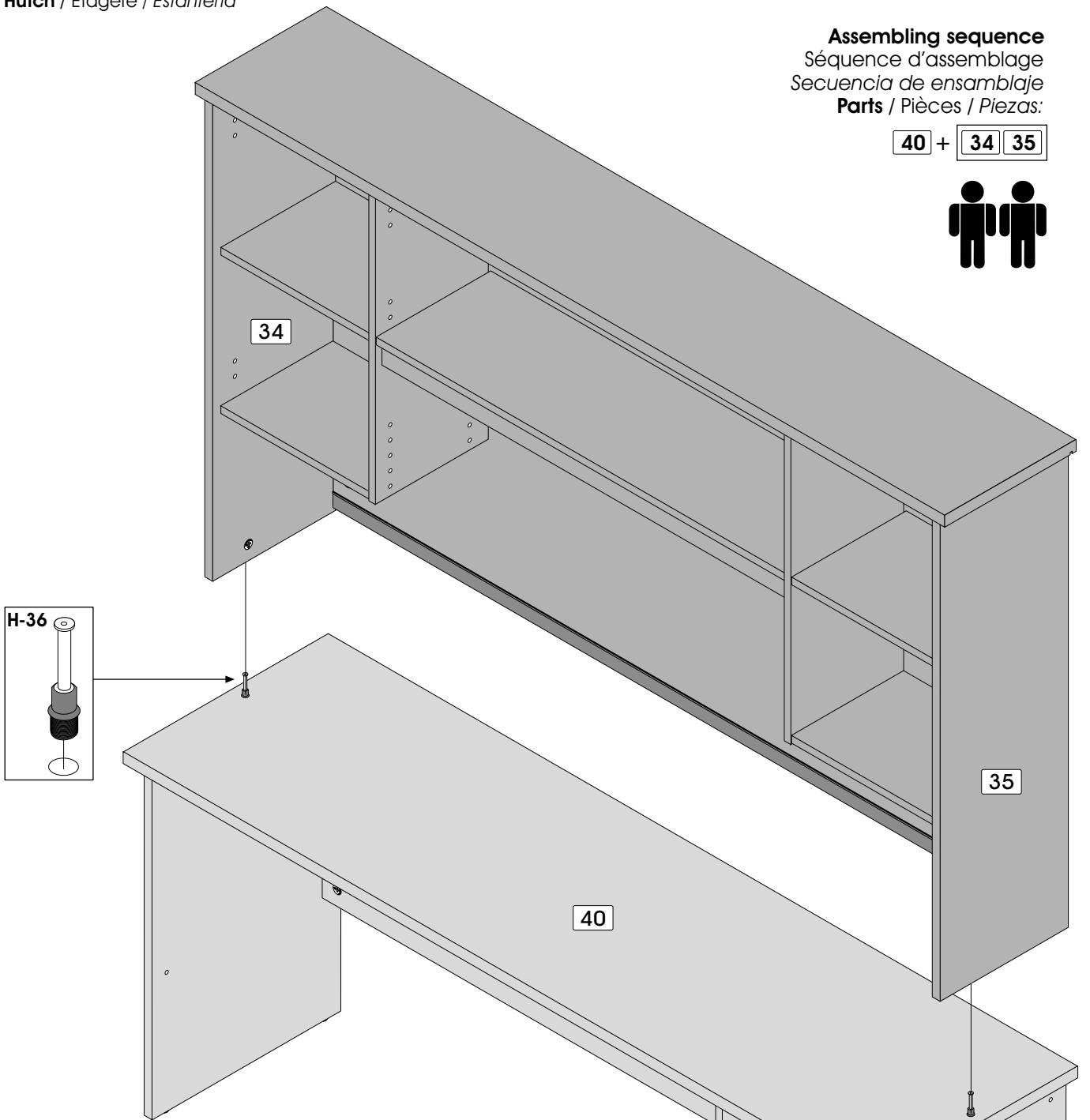

**important / importante**

**A**

↑  
insert  
insérez  
insertar

**B**

tighten  
serrez  
apretar

*(Note: Diagram B also includes a crossed-out arrow indicating not to over-tighten.)*

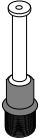
9	
<b>Code / Código</b>	H-36
<b>Qty / Qté / Cant.</b>	x 2

# 10 HARDWARE INSTALLATION / INSTALLATION DES QUINCAILLERIES / INSTALACIÓN DE LAS QUINCALLAS

Doors & Drawers / Portes et tiroirs / Puertas y cajones

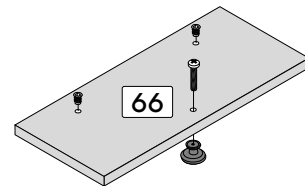
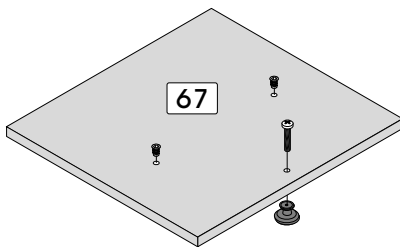
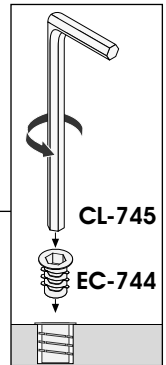
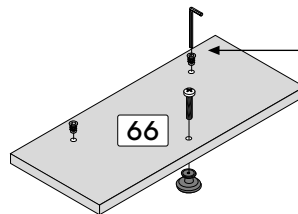
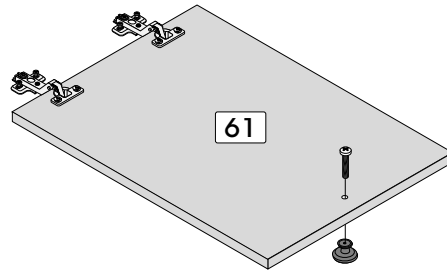
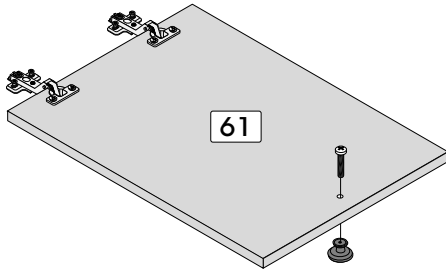
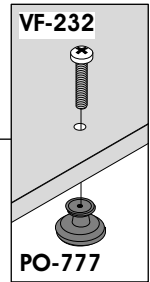
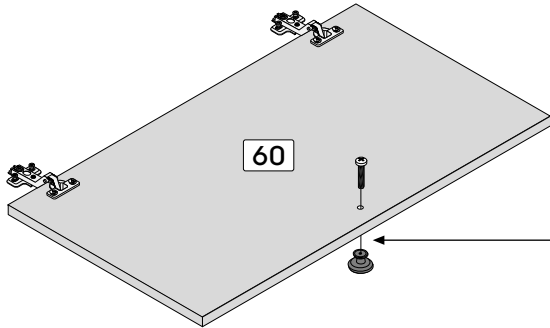
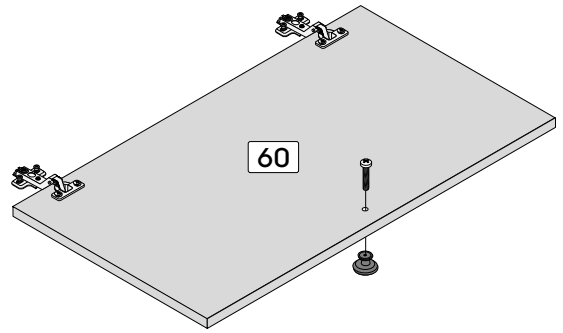
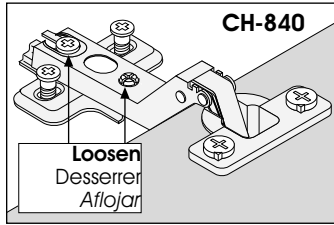

10

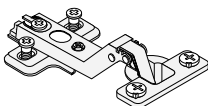

**Code / Código** CH-840  
**Qty / Qté / Cant.** x 8



**PO-777**  
x 7



**CL-745**  
x 1



**EC-744**  
x 6



**VF-232**  
7/16" (22 mm)  
x 7

**Drawers & Keyboard Shelf / Tiroirs et tablette à clavier / Cajónes y estante para teclado**

**important / importante**

Drive the screw all the way in to install CO-843.  
 Vissez à fond avant d'installer la CO-843.  
 Atornille a fondo antes de instalar el CO-843.

CO-843  
TC40C

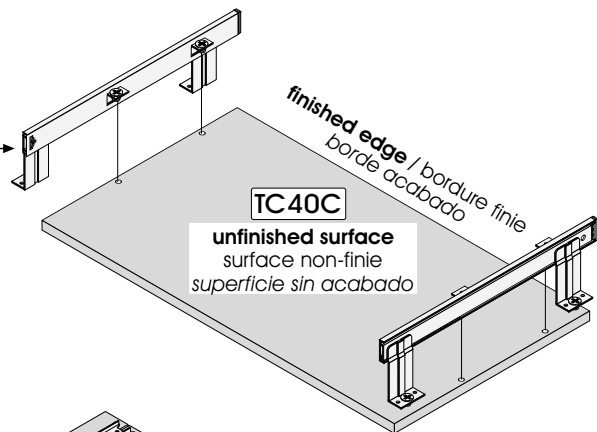

CA01A

right side /Upper Drawer  
côté droit / Tiroir supérieur  
costado derecho / Cajón superior

CA01A

left side /Upper Drawer  
côté gauche / Tiroir supérieur  
costado izquierdo / Cajón superior

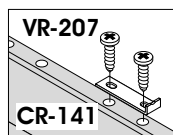

CA01A

side / face / lado "B"  
left side /Middle Drawer  
côté gauche / Tiroir central  
costado izquierdo / Cajón central

CA01A

side / face / lado "A"  
left side /Middle Drawer  
côté gauche / Tiroir central  
costado izquierdo / Cajón central

CA01A

right side /Middle Drawer  
côté droit / Tiroir central  
costado derecho / Cajón central

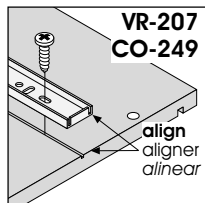

CA09A

left side  
côté gauche  
costado izquierdo

CA09A

right side  
côté droit  
costado derecho

<b>Code / Código</b>	CO-249	CO-843	CR-141	VR-207
<b>Qty / Qté / Cant.</b>	x 3	x 1	x 2	x 22

# 12 ASSEMBLY / ASSEMBLAGE / ENSAMBLAJE

## MIDDLE Drawer / Tiroir CENTRAL / Cajón CENTRAL

### Assembling sequence

Séquence d'assemblage

Secuencia de ensamblaje

Parts / Pièces / Piezas:

**CA05A CA01A CA01A** + **bottom / fond / fondo** + **CA05A 66**

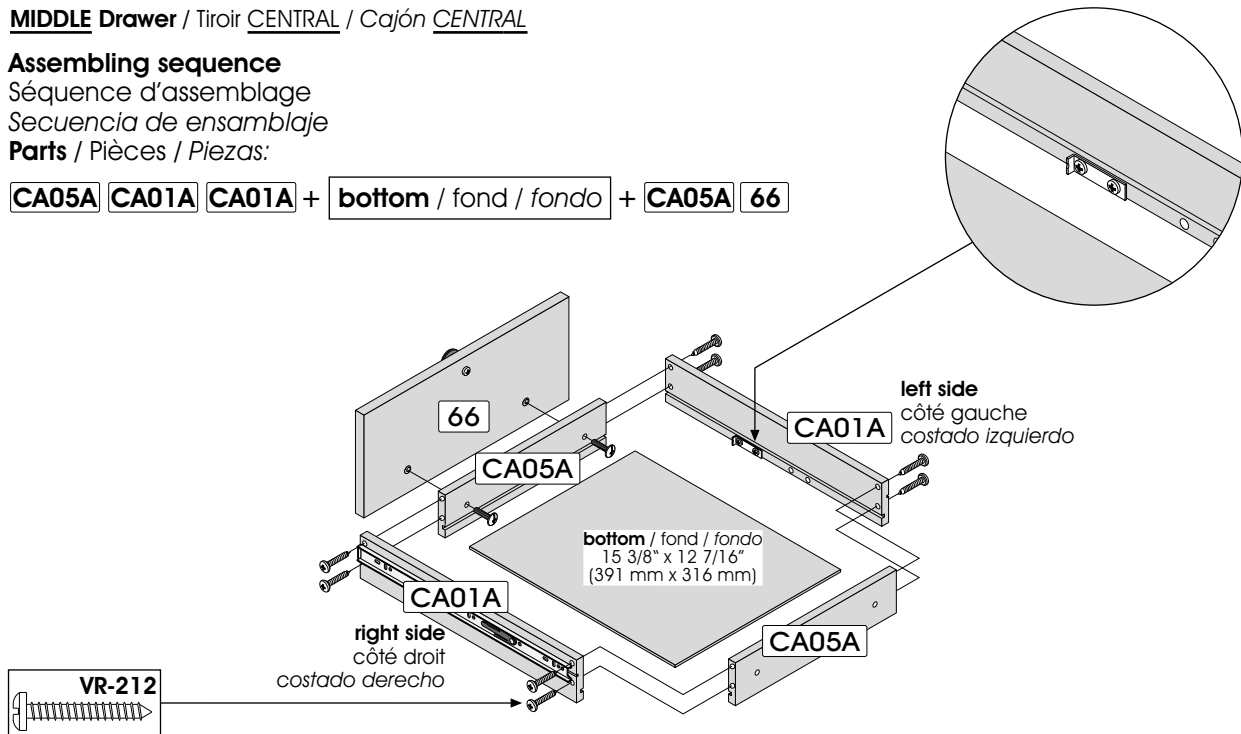

## UPPER Drawer / Tiroir SUPÉRIEUR / Cajón SUPERIOR

### Assembling sequence

Séquence d'assemblage

Secuencia de ensamblaje

Parts / Pièces / Piezas:

**CA05A CA01A CA01A** +

**bottom / fond / fondo** + **CA05A 66**

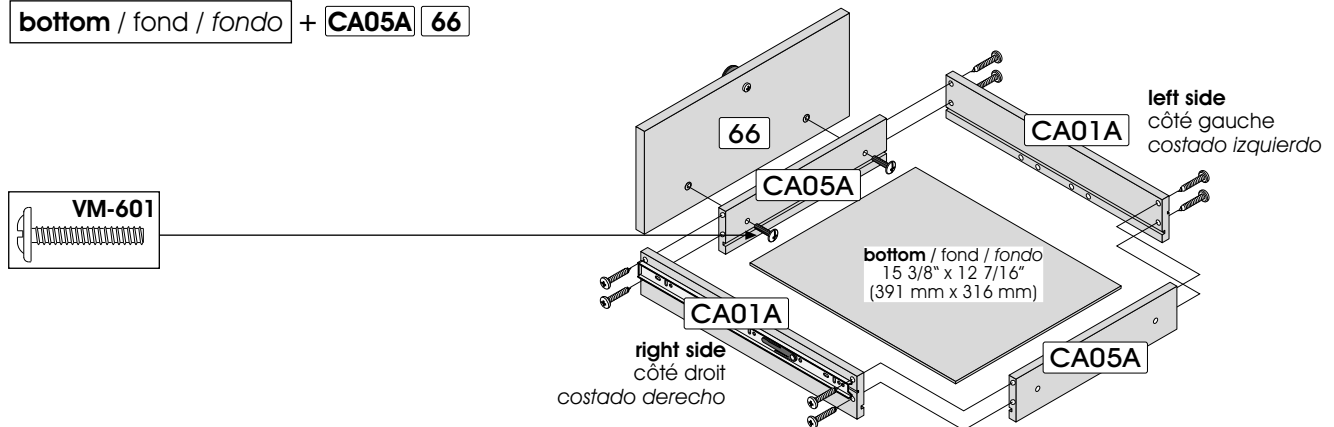

12



Code / Código VM-601

Qty / Qté / Cant. x 4



Code / Código VR-212

Qty / Qté / Cant. x 16

**Assembling sequence**  
 Séquence d'assemblage  
 Secuencia de ensamblaje  
**Parts / Pièces / Piezas:**

**CA13A EX-681** + **CA09A EX-702** + **CA09A EX-702** +  
**bottom / fond / fondo** + **CA13A EX-681** + **67**

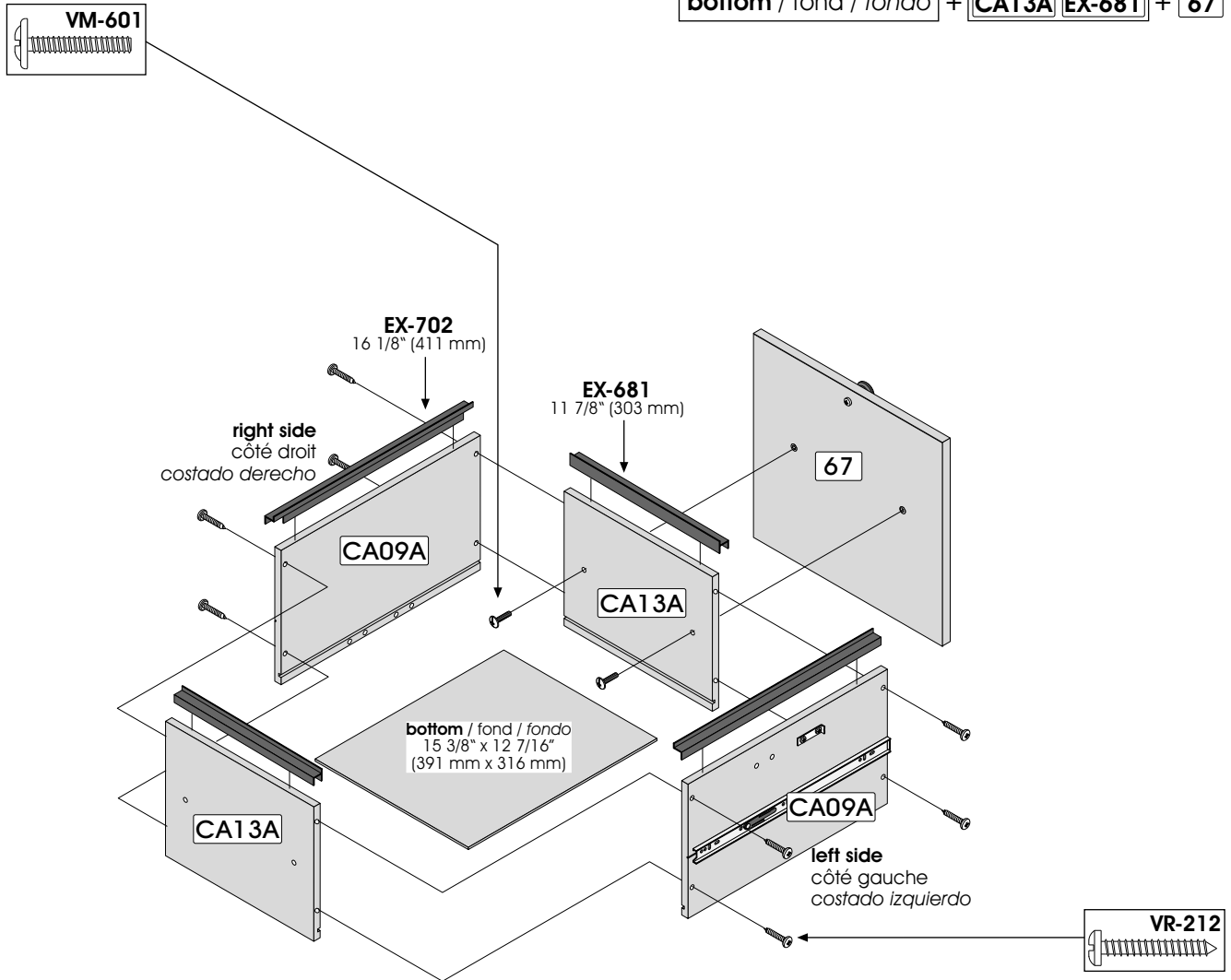

**Code / Código**

**Qty / Qté / Cant.**

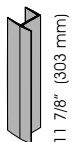

EX-681

x 2

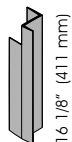

EX-702

x 2



VR-212

x 8



VM-601

x 2

### filing / rangement / orden

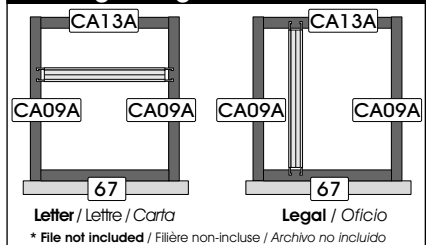

# 14 INSTALLATION / INSTALLATION / INSTALACIÓN

Use screw A for horizontal adjustment, screw B for depth adjustment and screws C for vertical adjustment.

Utilisez la vis A pour l'ajustement horizontal, les vis B pour l'ajustement en profondeur et les vis C pour l'ajustement vertical.

Utilice el tornillo A para realizar el ajuste horizontal, los tornillos B para el ajuste de profundidad y los tornillos C para el ajuste vertical.

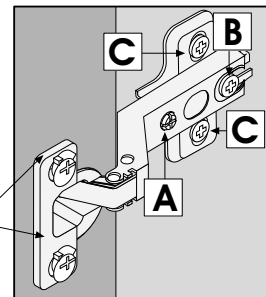

To remove hinges (CH-840), start by loosening these two screws to free the locking system.

Pour enlever les pentures (CH-840), desserrez ces deux vis d'abord pour libérer le système de verrouillage.

Para retirar las bisagras (CH-840), afloje primero estos dos tornillos para liberar el sistema de fijación.

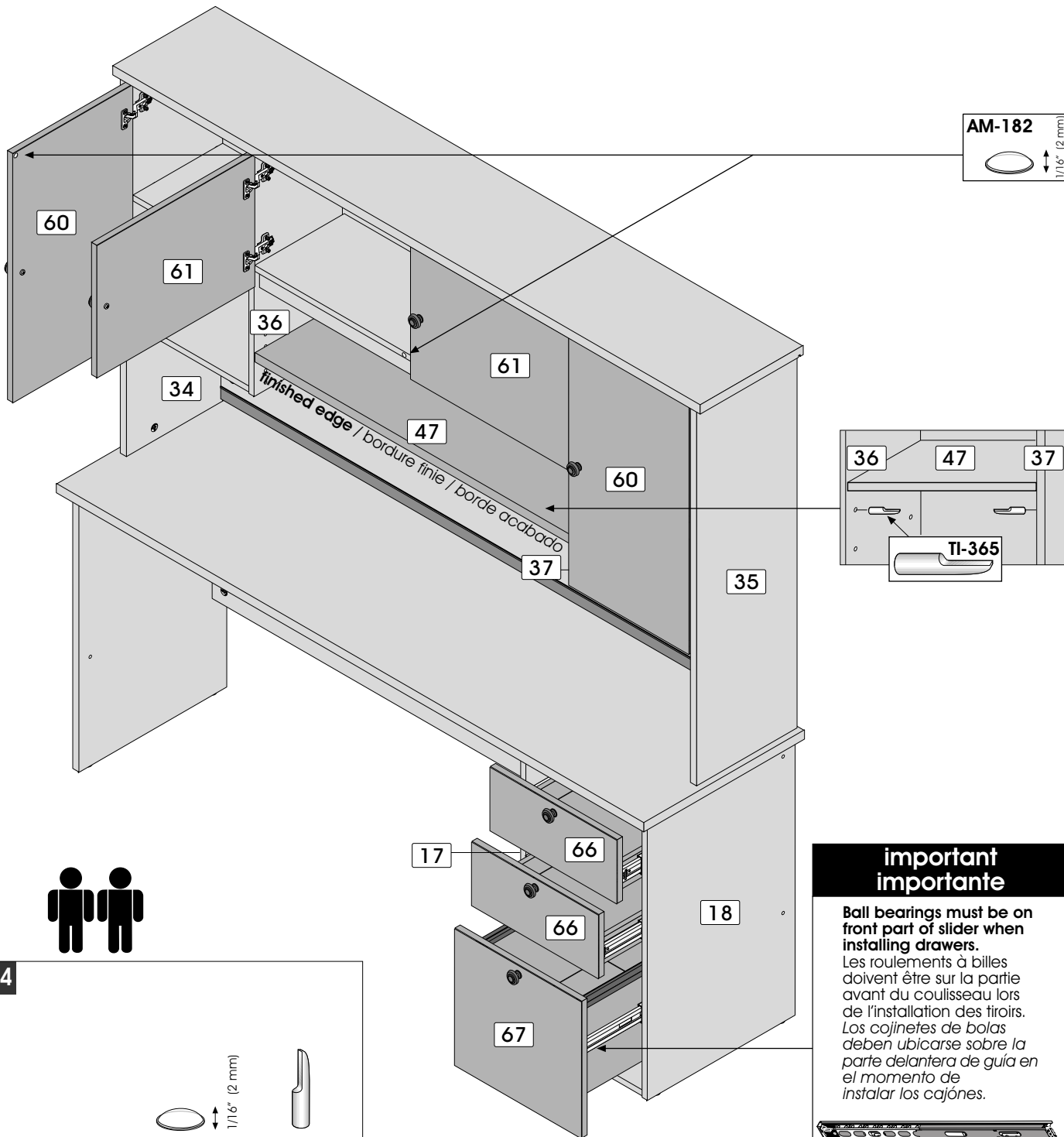

Code / Código	AM-182	TI-365
Qty / Qté / Cant.	x 4	x 4

**important**  
**importante**

Ball bearings must be on front part of slider when installing drawers.  
Les roulements à billes doivent être sur la partie avant du coulisseau lors de l'installation des tiroirs.  
Los cojinetes de bolas deben ubicarse sobre la parte delantera de guía en el momento de instalar los cajones.

# 15 HARDWARE INSTALLATION / INSTALLATION DES QUINCAILLERIES / INSTALACIÓN DE LAS QUINCALLAS

Desk / Bureau / Escritorio

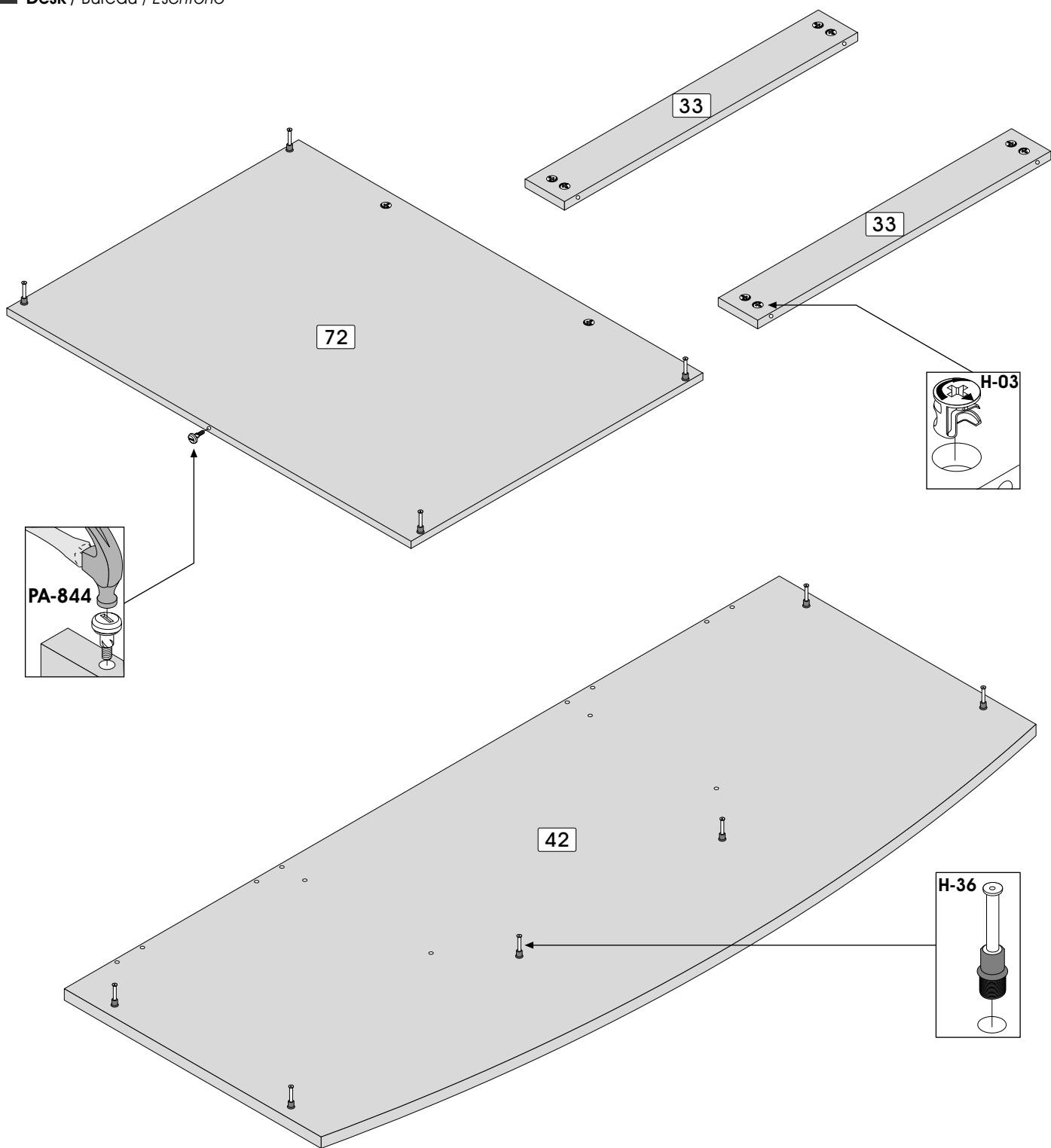

15

Code / Código

H-03

H-36

PA-844

Qty / Qté / Cant.

x 10

x 10

x 1

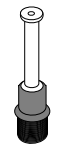

# 16 HARDWARE INSTALLATION / INSTALLATION DES QUINCAILLERIES / INSTALACIÓN DE LAS QUINCALLAS

Desk / Bureau / Escritorio

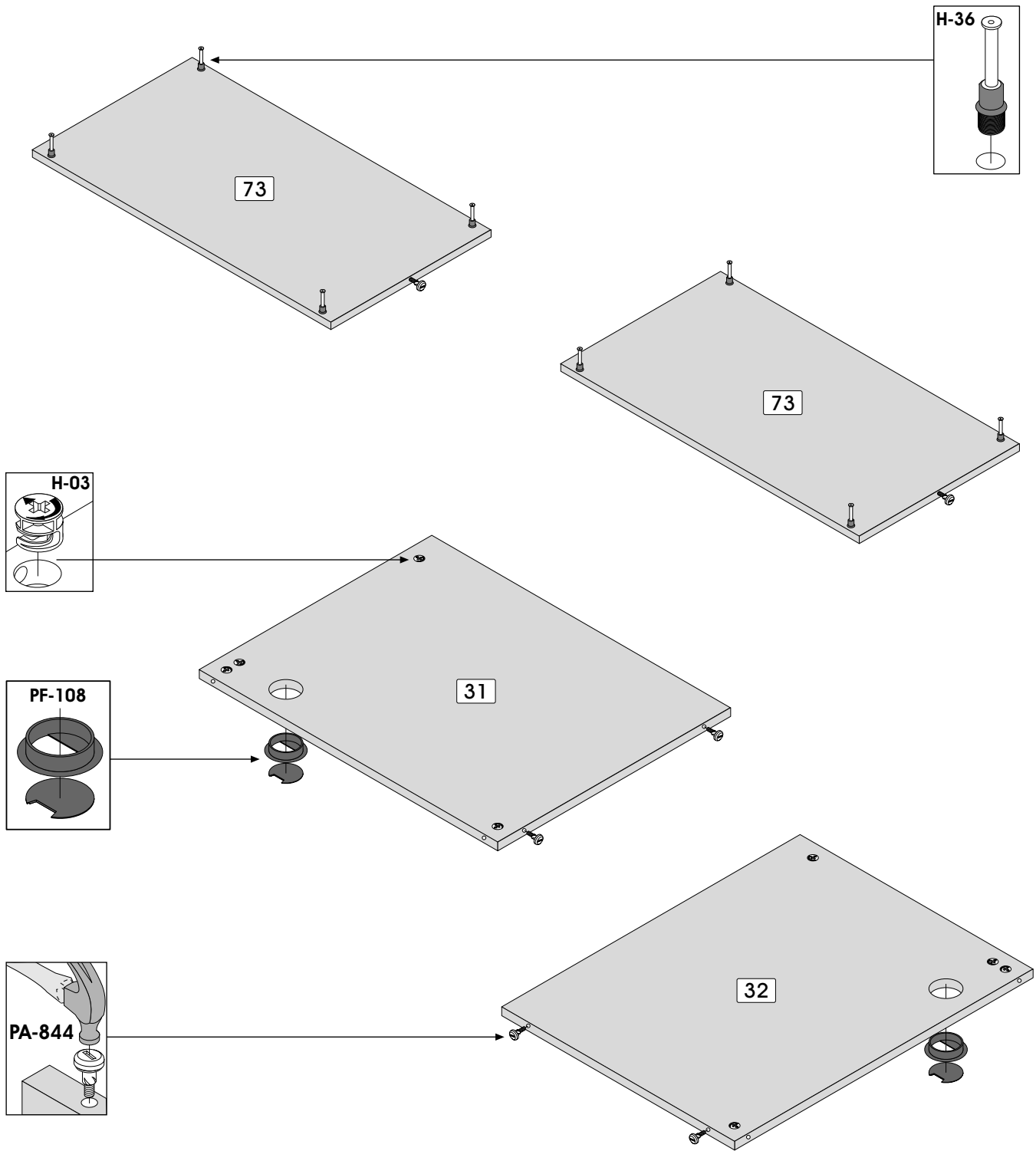

16

Code / Código

Qty / Qté / Cant.



H-03

x 8

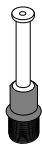

H-36

x 8



PA-844

x 6

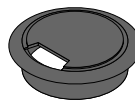

PF-108

x 2

# 17 ASSEMBLY / ASSEMBLAGE / ENSAMBLAJE

Desk / Bureau / Escritorio

## Assemble upside down

Assemblez en position renversée

Realice el ensamblaje en posición invertida

## Assembling sequence

Séquence d'assemblage

Secuencia de ensamblaje

Parts / Pièces / Piezas:

72 33 33 73 73 31 32 42

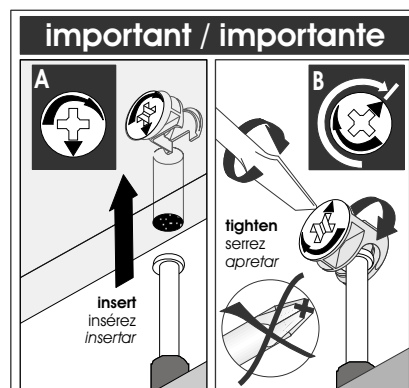
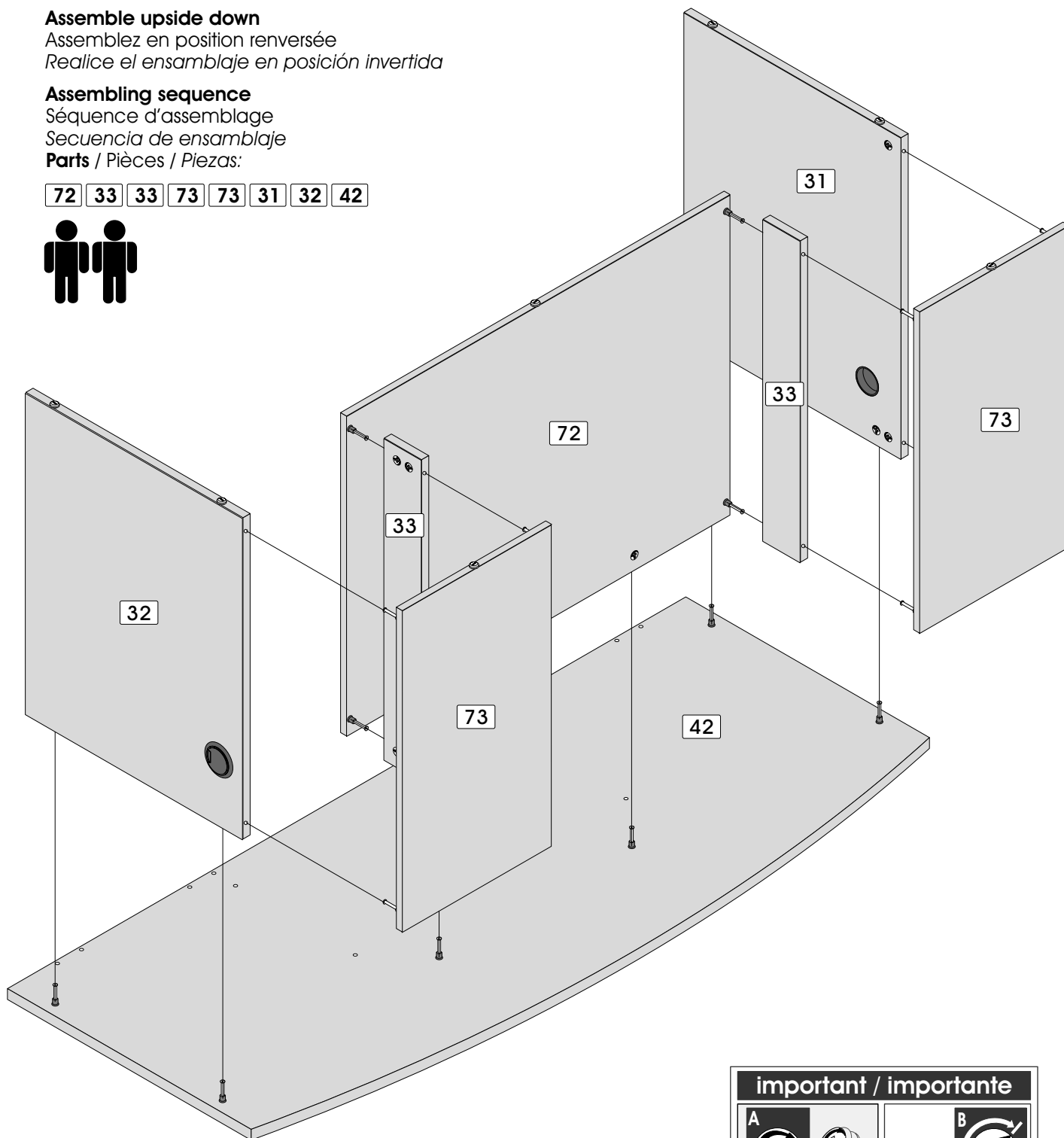

**important / importante**

**3 possibilities / 3 possibilités / 3 posibilidades**

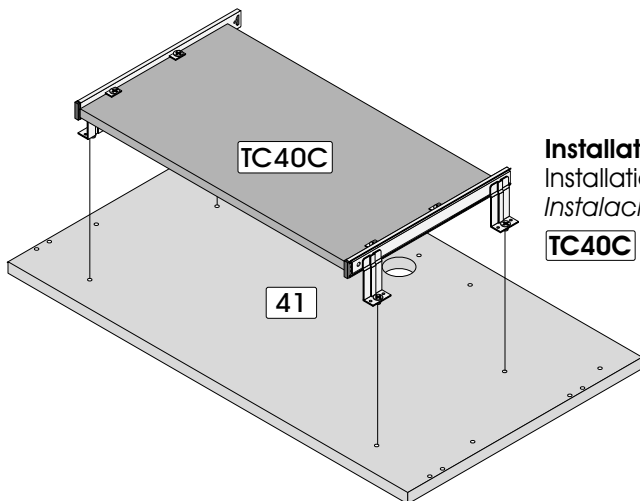
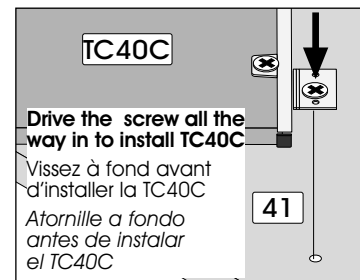

**Installation under the bridge**  
Installation sous le pont  
Instalación debajo el puente

**TC40C + 41**

**Installation under the credenza**  
Installation sous la crédence  
Instalación debajo el credencia

**TC40C + 40**

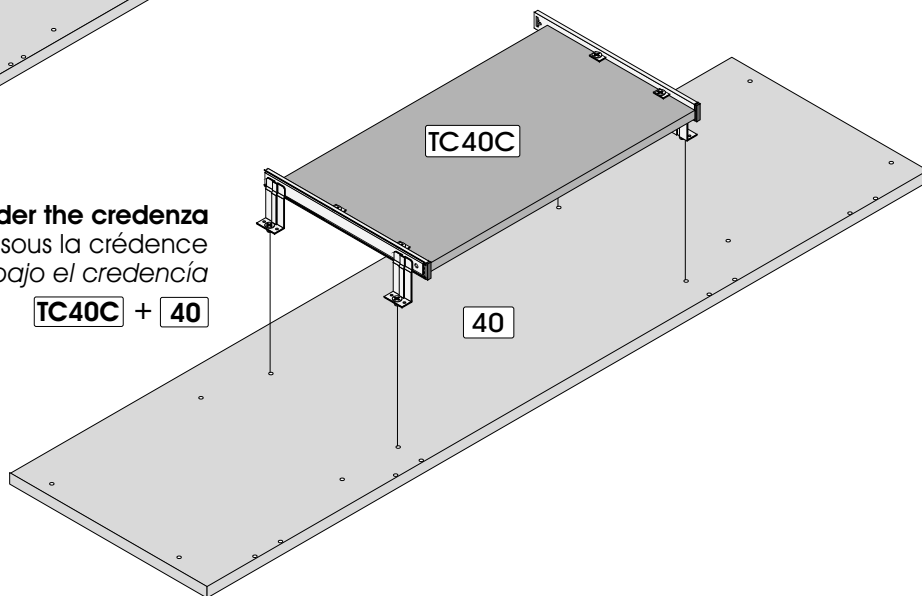

**Installation under the desk**  
Installation sous le bureau  
Instalación debajo el escritorio

**TC40C + 42**

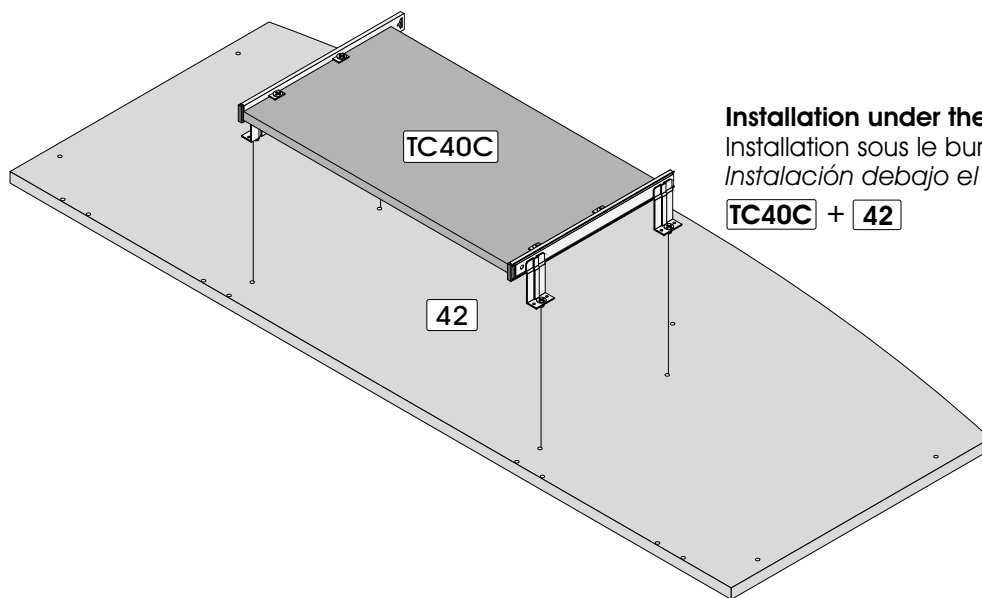

## Important/Importante

2 possibilities for right assembly / 2 possibilités pour l'assemblage droit / 2 posibilidades para el ensamblaje derecho

**For L-Shape configuration, please refer to pages 25 to 27.**

Pour la configuration en L, référez-vous aux pages 25 à 27.

Para la configuración en L, vea las páginas 25 à 27.

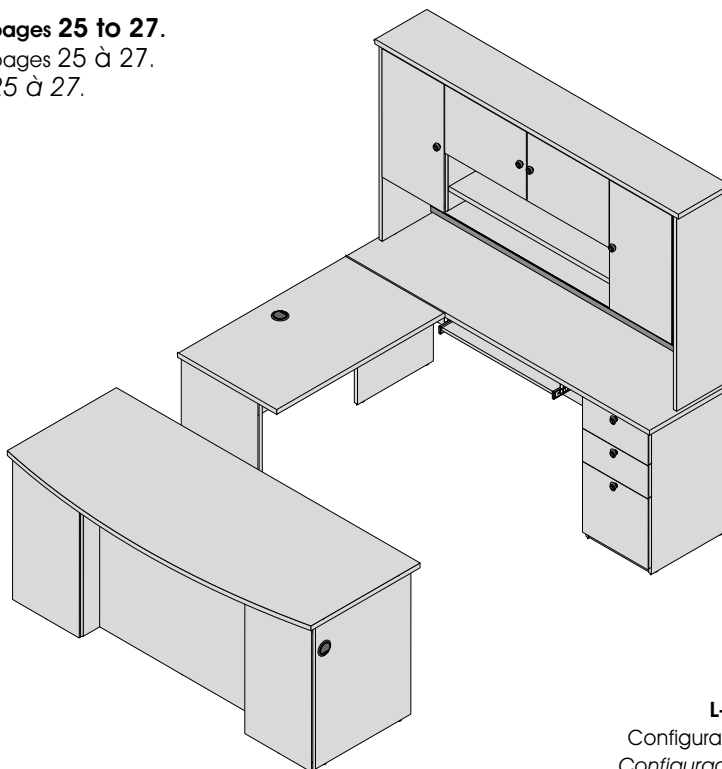

**L-Shaped**  
Configuration en L  
Configuración en L

**For U-Shape configuration, please refer to page 28.**

Pour la configuration en U, référez-vous à la page 28.

Para la configuración en U, vea la página 28.

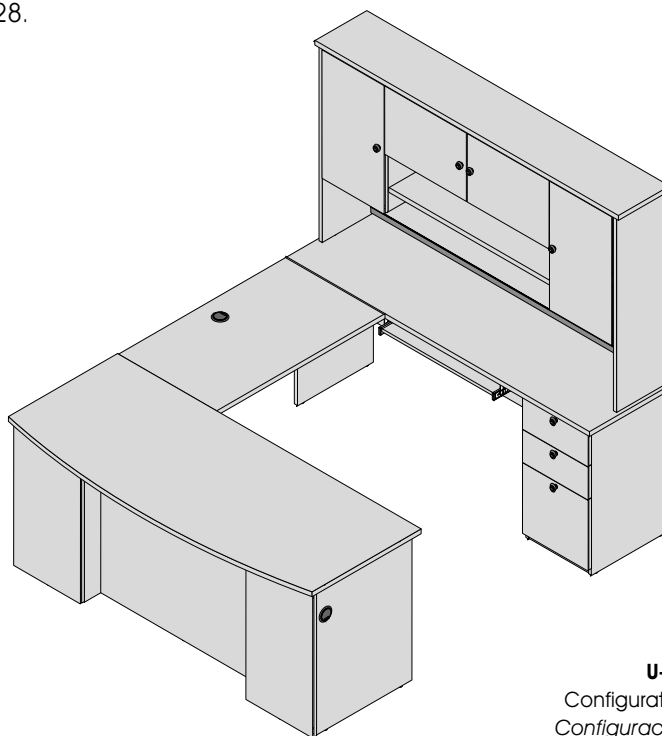

**U-Shaped**  
Configuration en U  
Configuración en U

# 19 HARDWARE INSTALLATION / INSTALLATION DES QUINCAILLERIES / INSTALACIÓN DE LAS QUINCALLAS

## Return Table / Table retour / Mesa ángulo

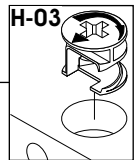
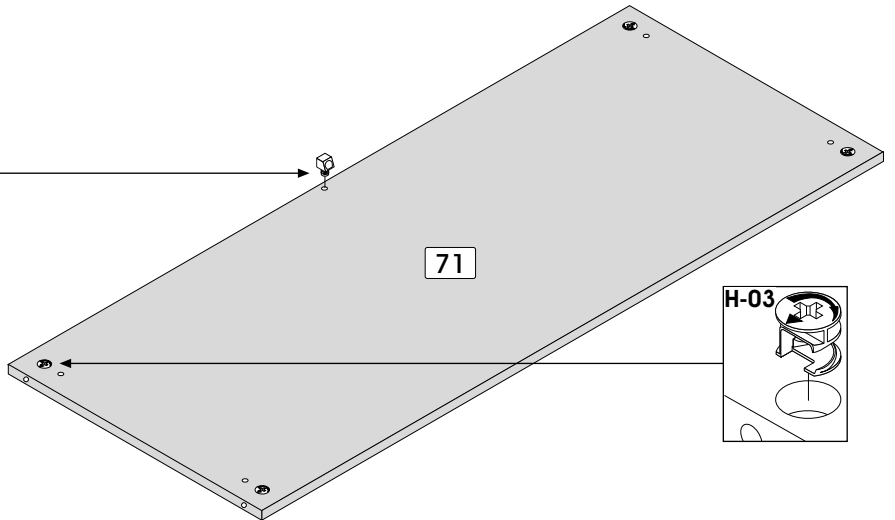
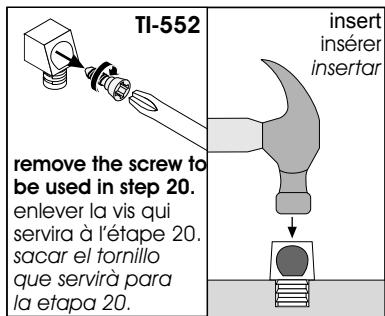
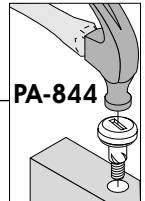
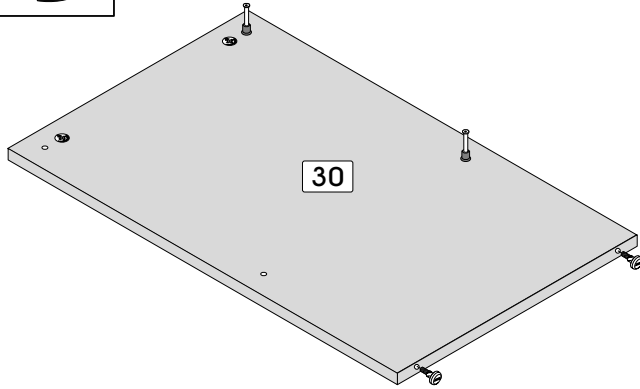
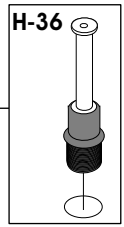
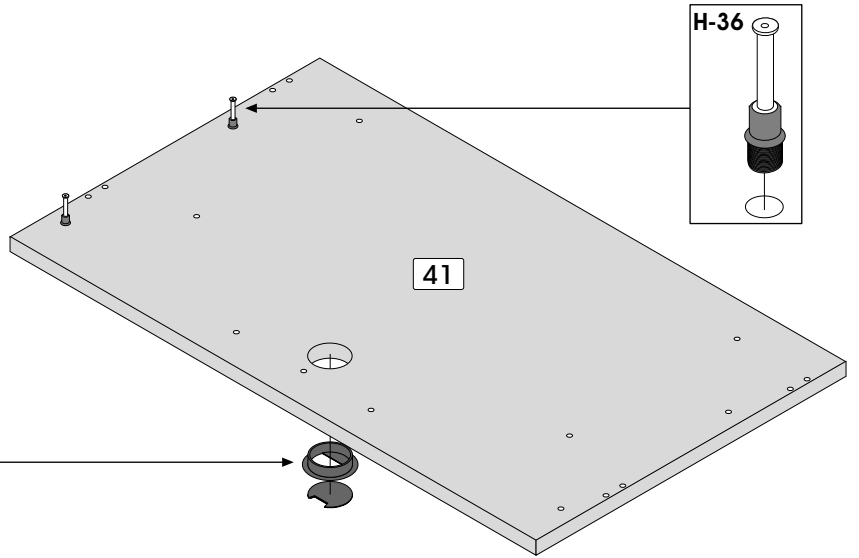
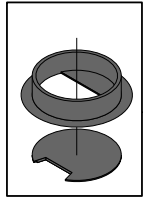
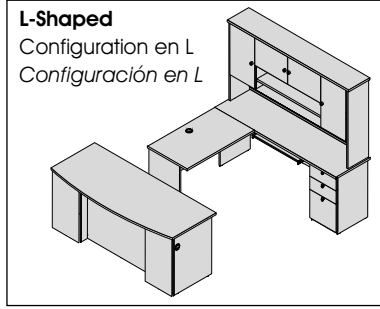

19

Code / Código

Qty / Qté / Cant.



H-03

x 6

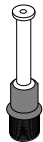

H-36

x 4



PA-844

x 2

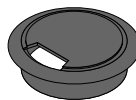

PF-108

x 1



TI-552

x 1

# 20 ASSEMBLY / ASSEMBLAGE / ENSAMBLAJE

Return Table / Table retour / Mesa ángulo

## Assemble upside down

Assemblez en position renversée

Realice el ensamblaje en posición invertida

## Assembling sequence

Séquence d'assemblage

Secuencia de ensamblaje

Parts / Pièces / Piezas:

41 30 71

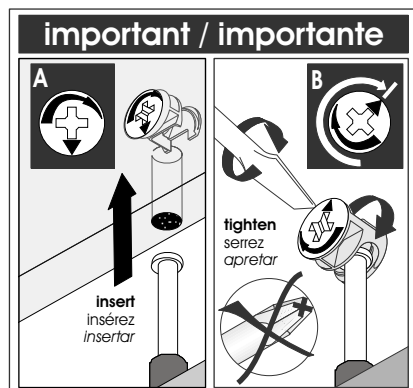
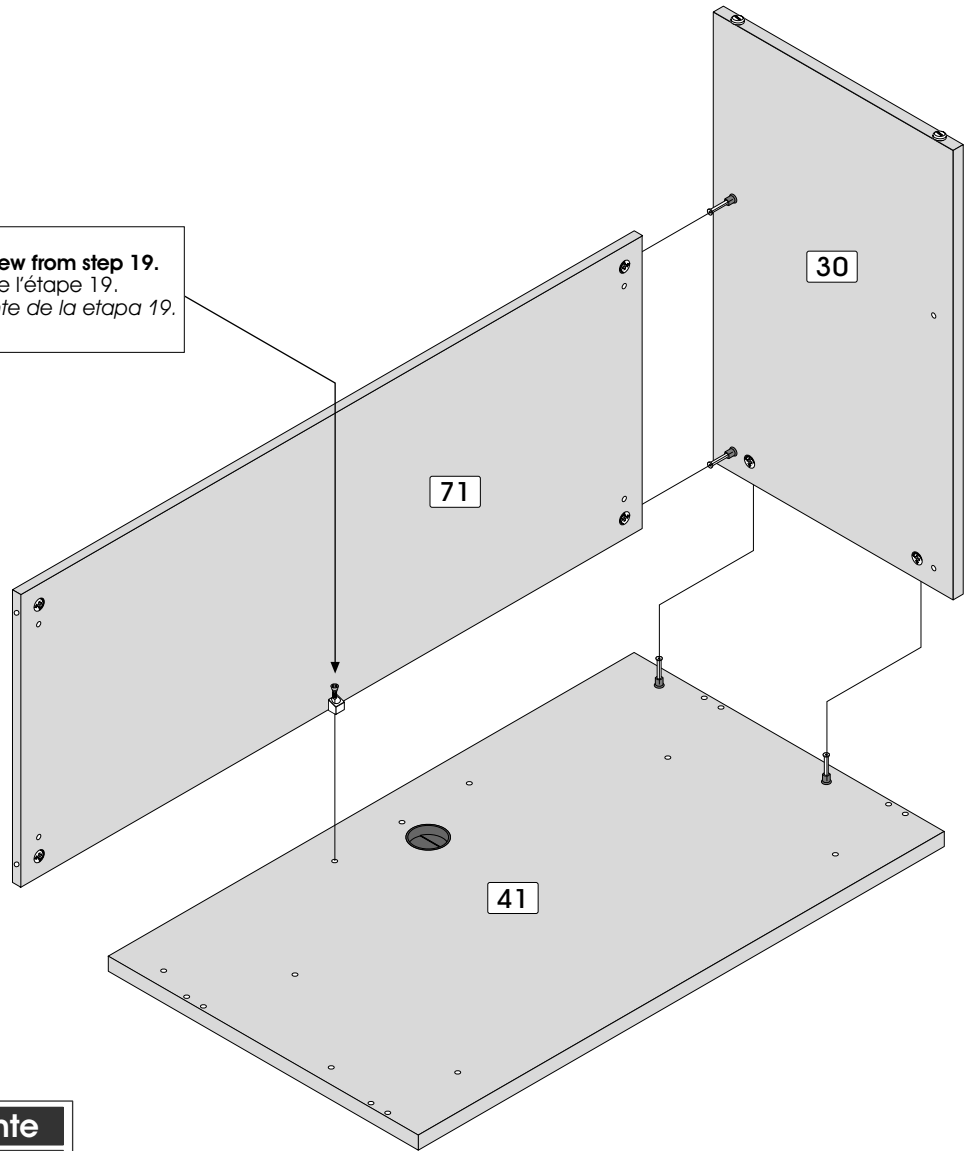

# 21 INSTALLATION / INSTALLATION / INSTALACIÓN

Return Table / Table retour / Mesa ángulo

## Assembling sequence

Séquence d'assemblage

Secuencia de ensamblaje

Parts / Pièces / Piezas:

30 40 + EQ-143 + 41 71

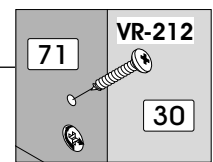
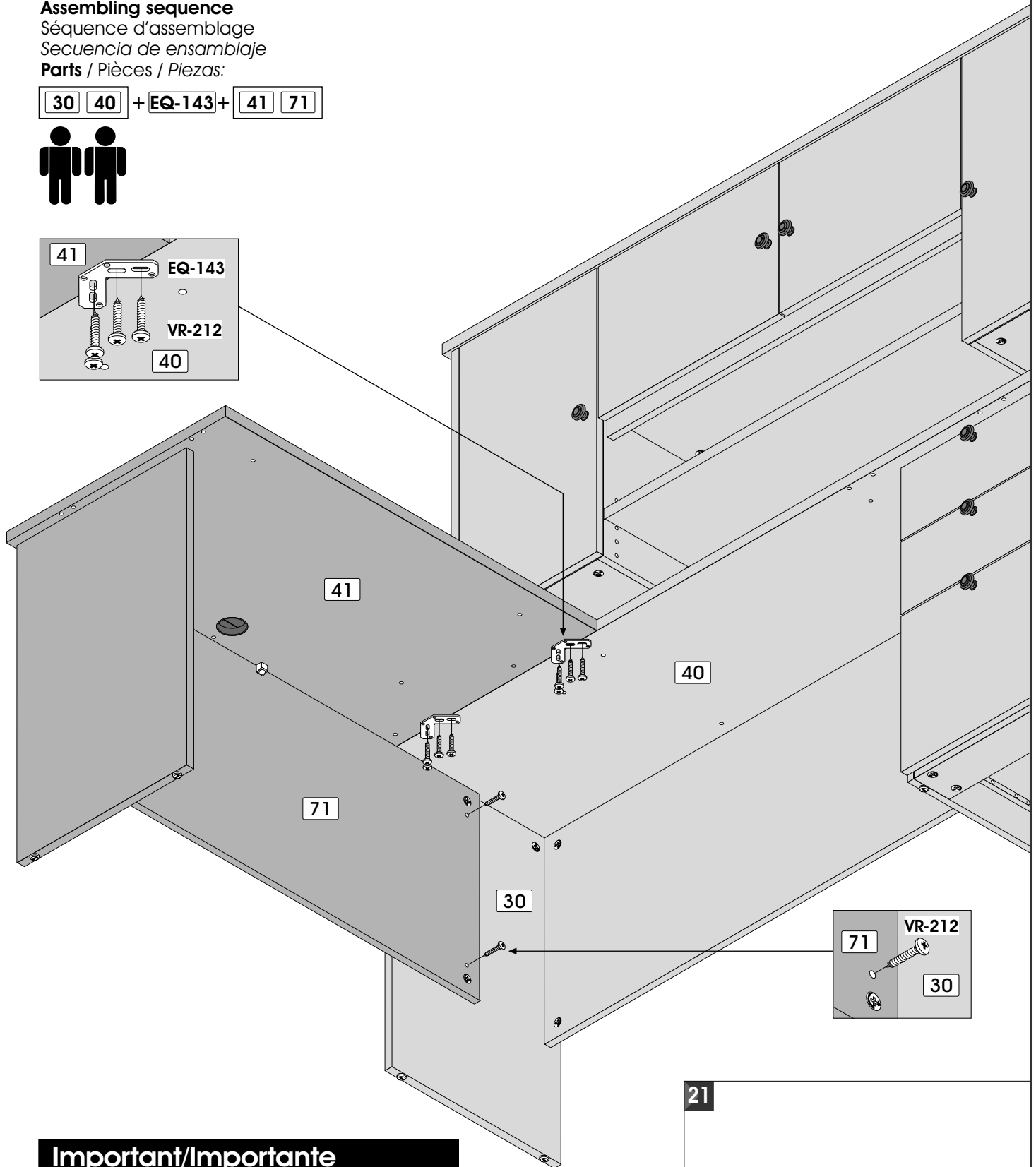
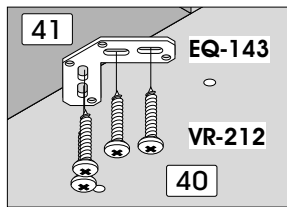
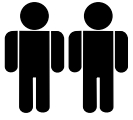

### Important/Importante

**Go to page 30 to complete the assembly**

Aller à la page 30 pour compléter l'assemblage  
Ir a la página 30 para completar el ensamblaje

21

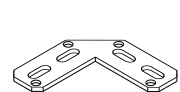

Code / Código

EQ-143

VR-212

Qty / Qté / Cant.

x 2

x 10

**Bridge / Pont / Puente**

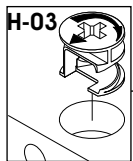
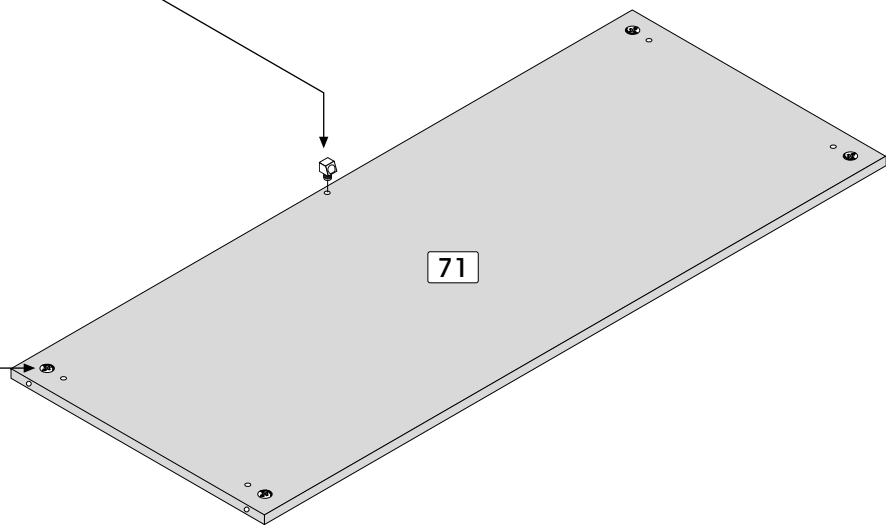
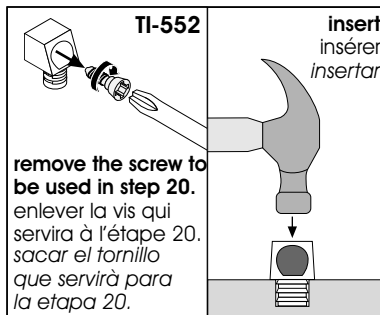
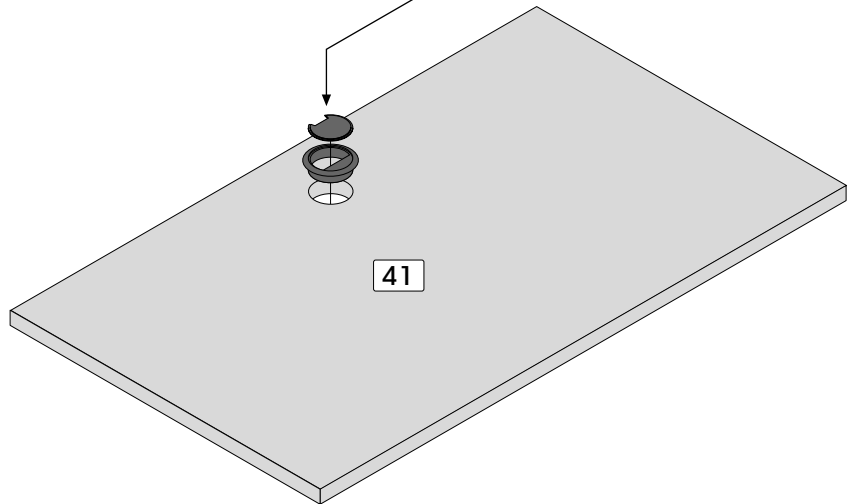
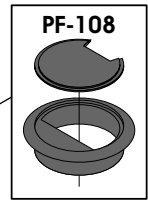
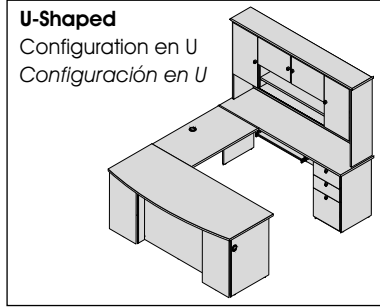

Code / Código

H-03

PF-108

TI-552

Qty / Qté / Cant.

x 4

x 1

x 1

# 20 INSTALLATION / INSTALLATION / INSTALACIÓN

Bridge / Pont / Puente

## Assembling sequence

Séquence d'assemblage

Secuencia de ensamblaje

Parts / Pièces / Piezas:

30 40 + EQ-143 + 31 42 +  
EQ-143 + 41 71



**TI-552**  Use the remaining screw from step 19.  
Utilisez la vis restante de l'étape 19.  
Utilizar el tornillo restante de la etapa 19.

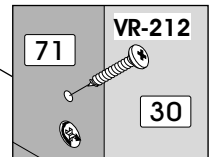
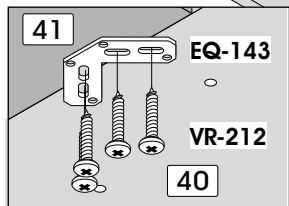
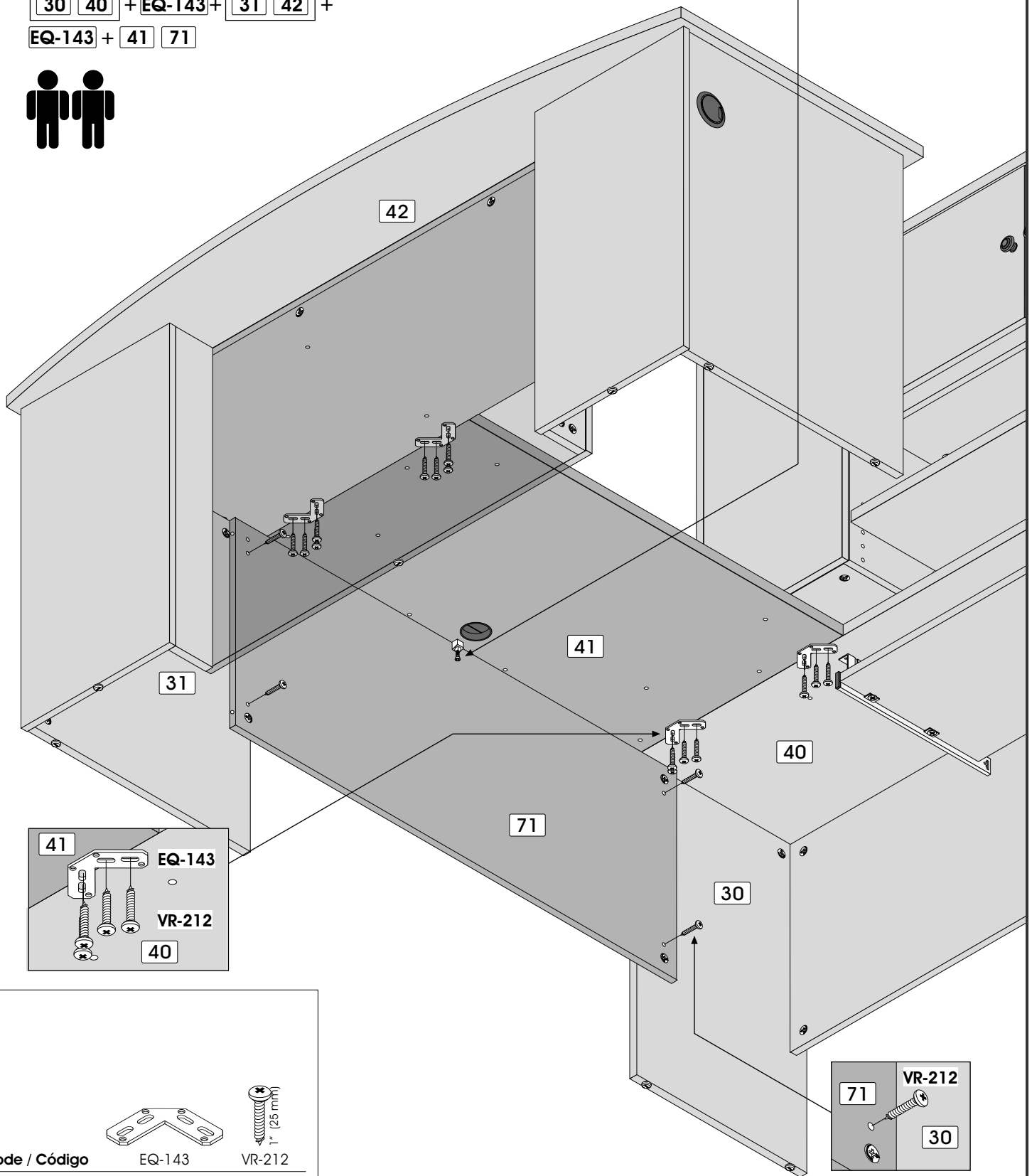

20

Code / Código

EQ-143

VR-212

Qty / Qté / Cant.

x 4

x 20

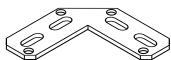

## Important/Importante

To better serve you!  
Pour mieux vous servir!

Model / Modèle: \_\_\_\_\_

Production Number  
Numéro de production: \_\_\_\_\_

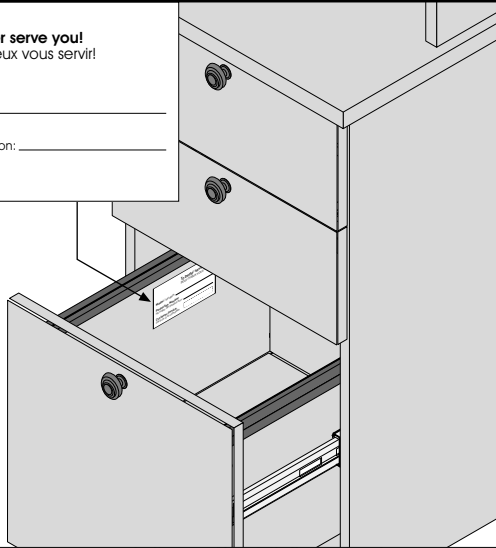

For future reference and to better serve you, please apply the self-adhesive sticker in an accessible space such as inside a drawer.

Pour mieux vous servir en cas de besoin, veuillez apposer l'autocollant dans un endroit facilement accessible tel que l'intérieur d'un tiroir.

Para uno mejor servicio en caso de necesidad, poner la etiqueta en uno lugar de fácil acceso como por ejemplo al interior de un cajón.

### When you have completed the assembly of your new furniture, install plastic caps

Lorsque vous avez complété l'assemblage de votre meuble, installez les capuchons de plastique

Una vez que haya completado el ensamblaje del mueble, coloque los capuchones de plástico

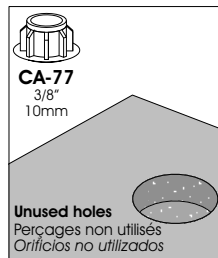
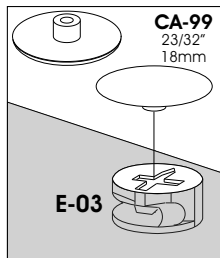

### PRODUCT CARE / ENTRETIEN DU PRODUIT / MANTENIMIENTO DEL PRODUCTO

**Avoid placing the furniture in the sunlight or near a source of heat. Use a soft dry cloth for dusting. To clean heavy dirt, use a cloth dipped in a solution of mild detergent and water. Avoid leaving wet objects on the surface or using commercial chemical cleaning products.**

Évitez d'exposer le meuble au soleil ou près de toute source de chaleur. Pour le nettoyage, utilisez un chiffon doux et sec. Pour la grosse saleté, utilisez un chiffon humidifié avec un peu de détergent dilué dans l'eau. Évitez de laisser des objets mouillés sur la surface de votre meuble ou d'utiliser des nettoyeurs chimiques.

Evite exponer el mueble al sol o las fuentes de calor. Para limpiarlo, utilice un paño suave y seco. Para limpiar las manchas rebeldes, utilice un trapo húmedo con un poco de detergente diluido en agua. No deje objetos mojados encima del mueble ni utilice limpiadores que contengan productos químicos. química.

**CONGRATULATIONS! YOU ARE NOW THE OWNER OF A QUALITY PRODUCT**  
FÉLICITATIONS! VOUS AVEZ MAINTENANT EN VOTRE POSSESSION UN PRODUIT DE QUALITÉ  
FELICITACIONES! AHORA ES USTED DUEÑO DE UN PRODUCTO DE CALIDAD.

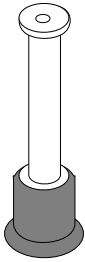

**You are at a step of hardware installation and some H-36 are missing:**

**Before calling to order your missing bolts (H-36), please make sure you have not installed any bolts (H-36) in the wrong place. To remove a bolt (H-36) which is not in the correct place, please refer to your instruction manual.**

Vous êtes à une étape d'installation de quincaillerie et il vous manque des H-36 :

Avant d'appeler pour commander des boulons (H-36), assurez-vous de ne pas avoir installé des boulons (H-36) au mauvais endroit. Pour enlever un boulon (H-36) mal situé, consultez le feuillet d'instructions.

*Usted está en alguna etapa de la instalación de quincallas y le faltan las H-36 :*

*Antes de llamar para pedir los pernos (H-36), asegúrese de que no los haya instalado en el lugar equivocado.*

*Para retirar un perno (H-36) mal puesto, consulte el folleto de instrucciones.*

**How to separate and install your CO-249 and CO-684 slides:**

**The CO-249 & CO-684 slides consist of two sections which you must separate. To separate the slides, please refer to your instruction manual. The slides are installed on distinct parts which will be re-grouped only when the drawers are installed on the furniture.**

Comment séparer et installer les coulisseaux CO-249 et CO-684 :

Les coulisseaux CO-249 et CO-684 sont constitués d'une partie que vous devez séparer en deux sections. Pour séparer le coulisseau, référez-vous au feuillet d'instructions. Les coulisseaux sont installés sur deux pièces distinctes et seront regroupés seulement lors de l'installation des tiroirs dans le meuble.

*Cómo separar y instalar las guías correderas CO-249 y CO-684 :*

*Las guías correderas CO-249 y CO-684 están constituidas por una parte que usted debe separar en dos secciones. Para separar las guías correderas, consulte el folleto de instrucciones. Las guías correderas se instalan en dos piezas distintas y sólo serán reagrupadas una vez que se instalen los cajones en el mueble.*

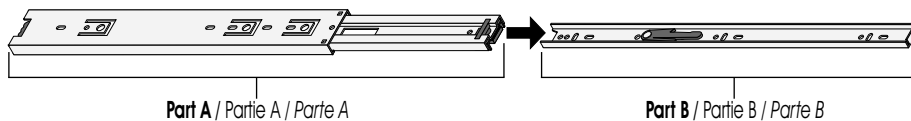

**The doors on your furniture are crooked or the space between the doors is uneven:**

**It is very important to install the hinges and hinge plates on the correct parts while respecting the instruction manual. For the installation and adjustment of the doors, please refer to your instruction manual or log on.**

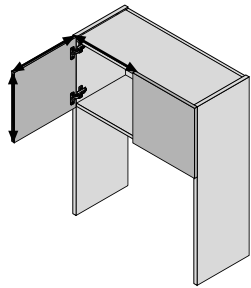

Les portes de votre meuble sont croches ou l'espace qui les sépare est inégal :

Il est important d'installer les pentures et les plaques sur les bonnes pièces en respectant le feuillet d'instructions. Pour l'installation des portes et leur ajustement, référez-vous à l'étape d'installation des portes dans le feuillet d'instructions ou sur le site internet de .

*Las puertas de su mueble están chuecas o el espacio que las separa es desigual :*

*Es importante instalar las bisagras y las placas sobre las piezas adecuadas respetando el folleto de instrucciones. Para la instalación de las puertas y su ajuste, consulte la etapa de instalación de las puertas en el folleto de instrucciones o en el sitio Internet de .*

**The drawers on your furniture are crooked or the space between the drawers is uneven:**

**While referring to the section indicating the actual sizes of the screws in your instruction manual , please insure that you are using the correct size screws needed when installing your drawer slides and drawer fronts. They must be installed straight. While installing the drawer front, make sure that the correct side is facing up. For the adjustment of the drawer fronts, please refer to your instruction manual or log on.**

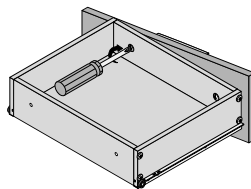

Les tiroirs de votre meuble sont croches ou l'espace qui les sépare est inégal :

En vous référant au tableau de vis grandeur réelle du feuillet d'instructions, assurez-vous que vous avez utilisé les bonnes vis lors de l'installation des coulisseaux ainsi que du devant de tiroir et qu'elles sont posées bien droites. Assurez-vous également que le devant du tiroir n'est pas assemblé à l'envers. Référez-vous à l'étape d'ajustement des tiroirs dans le feuillet d'instructions ou sur le site internet de .

*Los cajones de su mueble están chuecos o el espacio que los separa es desigual :*

*Consulte la tabla de tornillos en tamaño real del folleto de instrucciones y asegúrese de que haya utilizado los tornillos adecuados durante la instalación de las guías correderas así como también la parte delantera del cajón y que éstos estén puestos bien derechos. Asegúrese también de que la parte delantera del cajón no esté ensamblada al revés. Consulte la etapa de ajuste de cajones en el folleto de instrucciones o en el sitio Internet de .*



**For more information or to discover our new products**

Pour toute information ou pour découvrir nos nouveaux produits

*Para obtener más información o para obtener nuevos productos*



**FOR LONG TIME**  
POUR LONGTEMPS  
*POR MUCHO TIEMPO*



**OUR FURNITURE IS GARANTEED FOR 10 YEARS. NO MATTER THE PROBLEM, OUR CUSTOMER SERVICE IS THERE FOR YOU.**

NOS MEUBLES SONT GARANTIS POUR 10 ANS. PEU IMPORTE LE PROBLÈME, N'HÉSITÉZ PAS À COMMUNIQUER AVEC NOTRE SERVICE À LA CLIENTÈLE.

*NUESTROS MUEBLES TIENEN UNA GARANTIA DE 10 AÑOS. NO IMPORTA EL PROBLEMA, COMUNIQUE CON NUESTRO SERVICIO À CLIENTE.*