

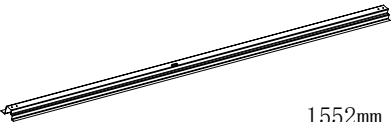









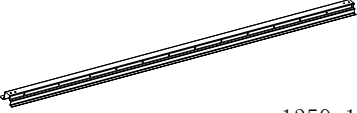
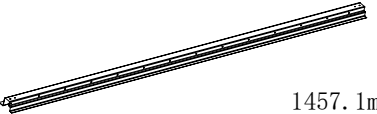
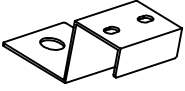
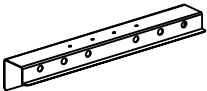



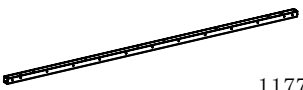

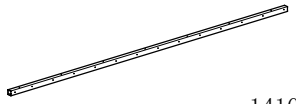
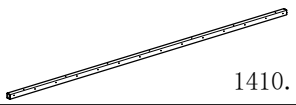
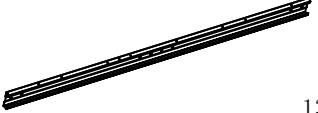

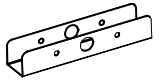
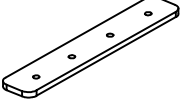

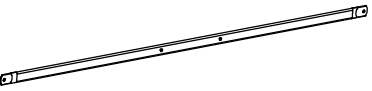
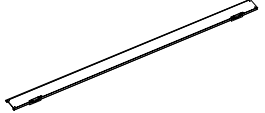
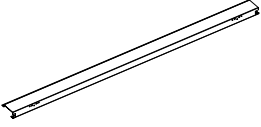
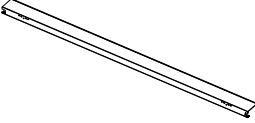
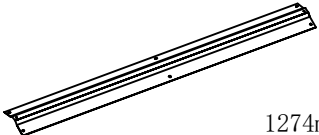
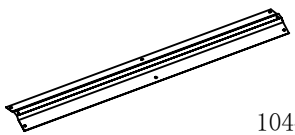



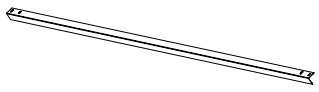
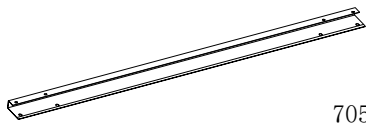
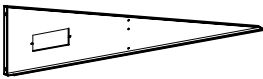
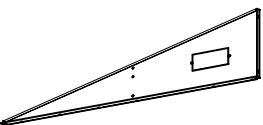
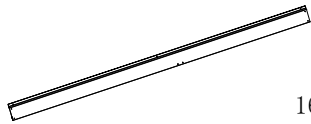
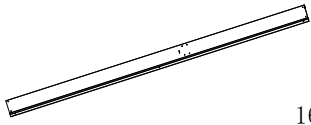



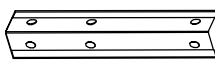



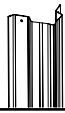
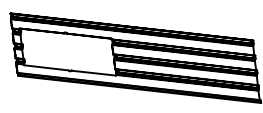

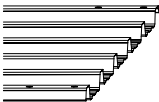
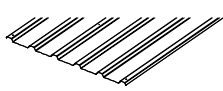
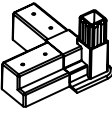

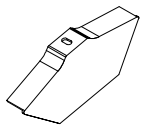

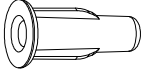
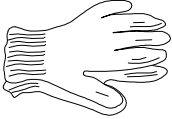
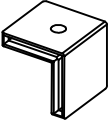
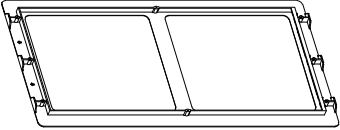
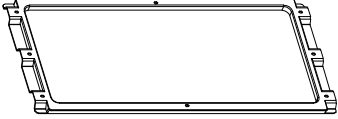
NO.	PART.	Qty.
1L	 627.6mm	1
1	 1552mm	1
1R	 627.6mm	1
2	 642mm	2
3L	 1350.1mm	3
3R	 1457.1mm	3
4		7
4B	 200mm	7
5	 1610mm	4
6	 1605mm	1
6L	 607.7mm	1
6R	 607.7mm	1
7	 1177mm	2
7F	 1142.7mm	2

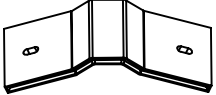

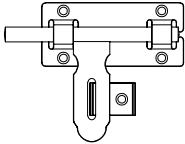
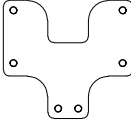
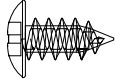
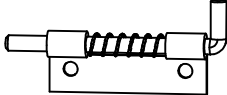

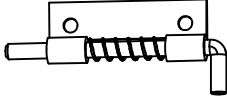
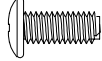

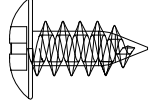
NO.	PART.	Qty.
7B	 1142.7mm	2
8L	 1410.2mm	1
8R	 1410.2mm	1
9	 1391mm	2
9F	 1426.8mm	2
9B	 731.3mm	2
10		7
11	 180mm	4
11L	 320mm	2
11R	 320mm	2
15	 980.7mm	4
16	 1652mm	2
17L	 1660mm	1
17R	 1660mm	1

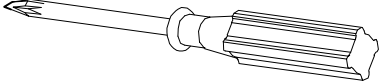
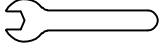
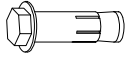
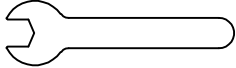
NO.	PART.	Qty.
18F	 1274mm	2
18B	 1044mm	1
19L	 1274mm	2
19	 1044mm	2
19R	 1274mm	2
20	 1545.5mm	4
21	 705mm	4
21L		2
21R		2
22	 1652mm	1
23	 1652mm	1
24	 1149.5mm	4
25	 1599.5mm	4
26	 1000mm	4





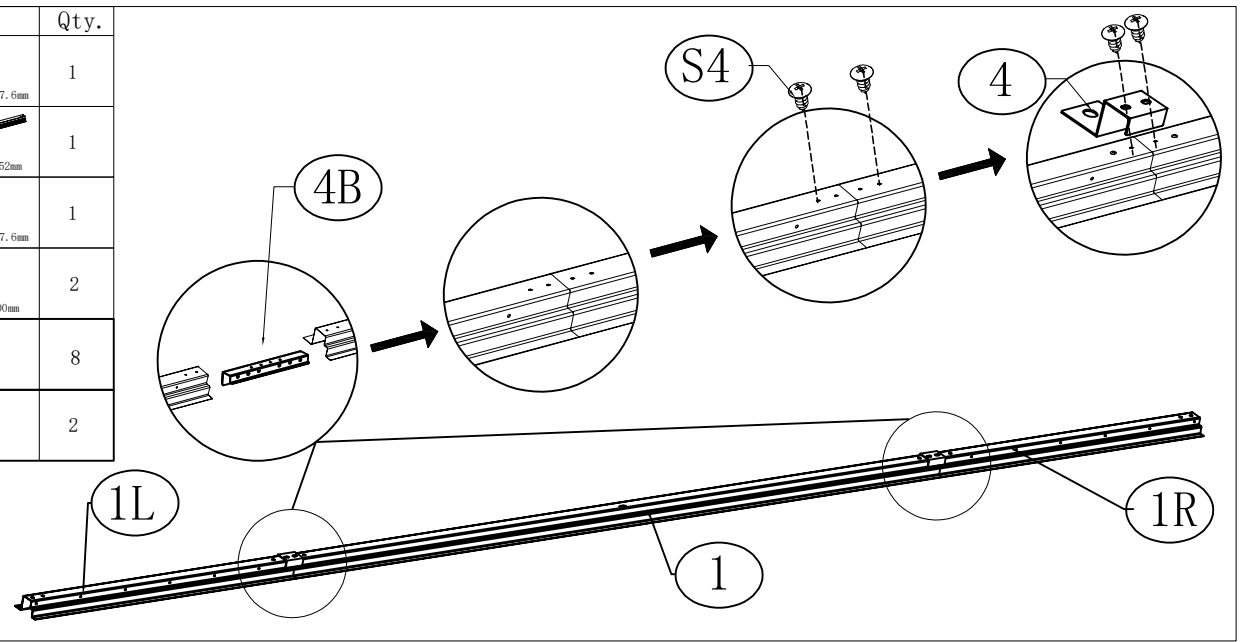

NO.	PART.	Qty.
27	 165mm	4
38	 1468.5mm	4
W1	 1660mm	2
W3	 1660mm	6
W5	 1660mm	18
W7	 1660mm	4
C2	 1660mm	2
W12	 1537.5mm	16
W15	 1537.5mm	4
M1	 1650mm	2
C		4
F		4
F4		4
F5		2

NO.	PART.	Qty.
F6		4
F7		200
F8		110
F9		2
F10		4
F12		2
F13		2
F14		2
F18		2
S1		1
S2		1
S3		1
S4		562
S5L		1





NO.	PART.	Qty.
S5R		1
S6		127
S6A		10
S7		115
S8		16
S9		4
S12		1
S15		1
S34	 M6X50mm	7
S35		1

NO.	PART.	Qty.
1L	 627.6mm	1
1	 1552mm	1
1R	 627.6mm	1
4B	 200mm	2
S4		8
4		2

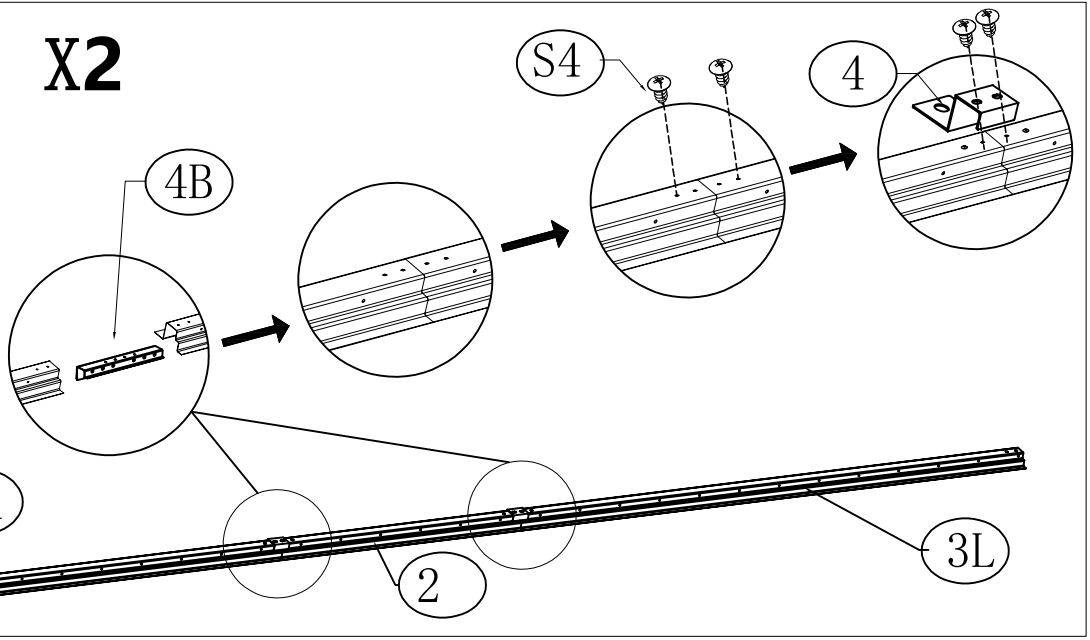



NO.	PART.	Qty.
3L	 1350.1mm	2
2	 642mm	2
3R	 1457.1mm	2
4B	 200mm	4
S4		16
4		4

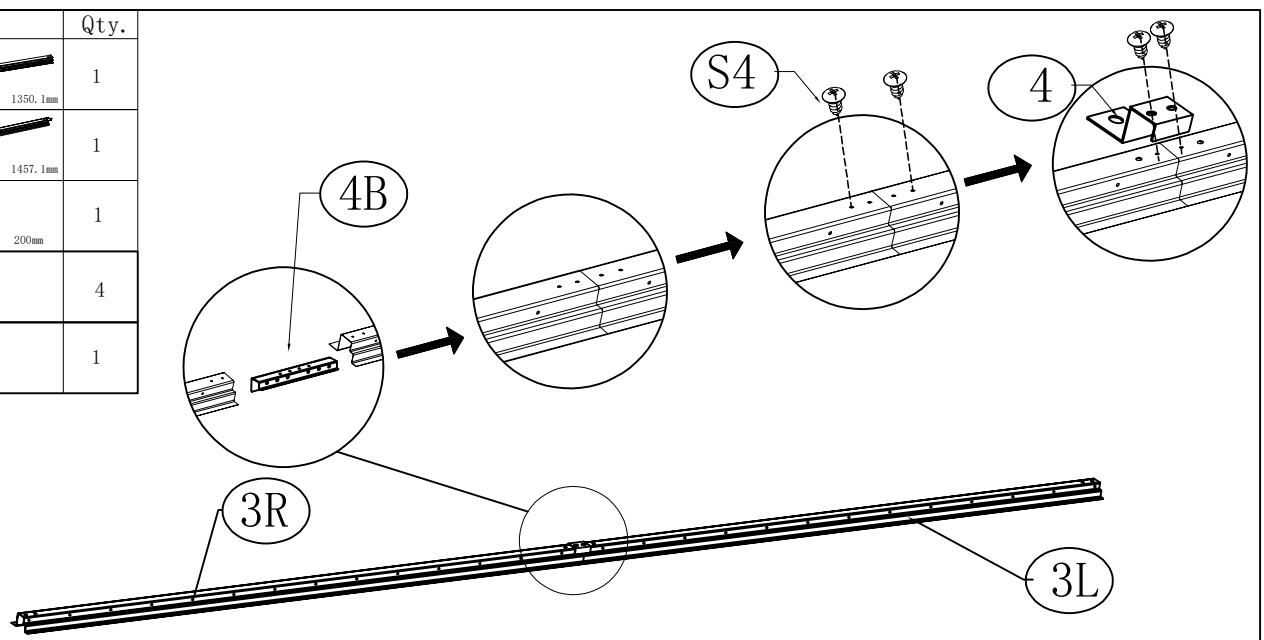

NO.	PART.	Qty.
3L	 1350.1mm	1
3R	 1457.1mm	1
4B	 200mm	1
S4		4
4		1





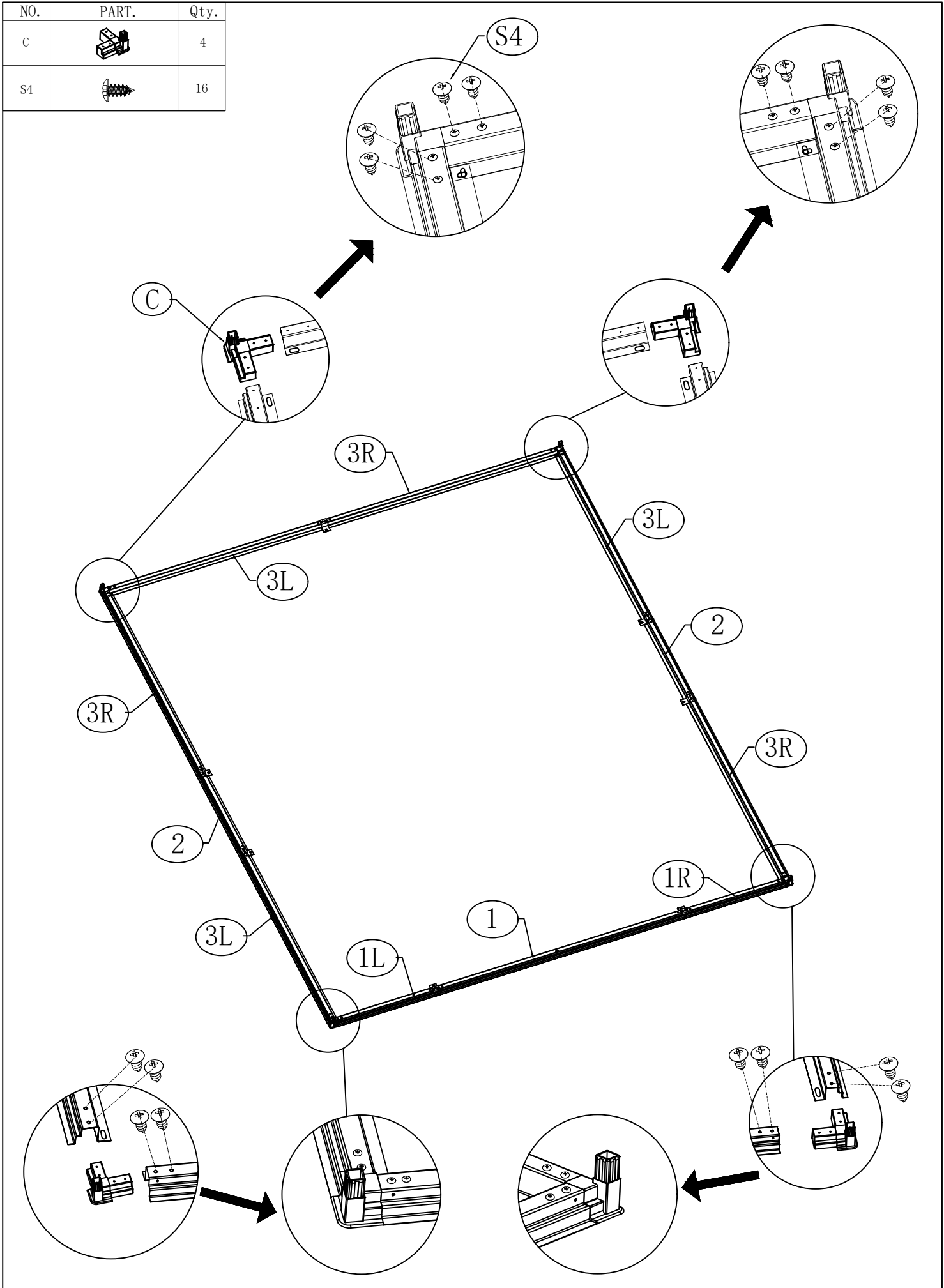

NO.	PART.	Qty.
C		4
S4		16

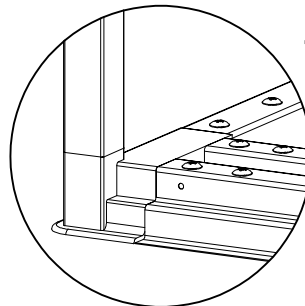
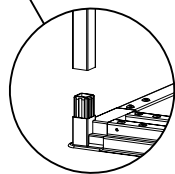
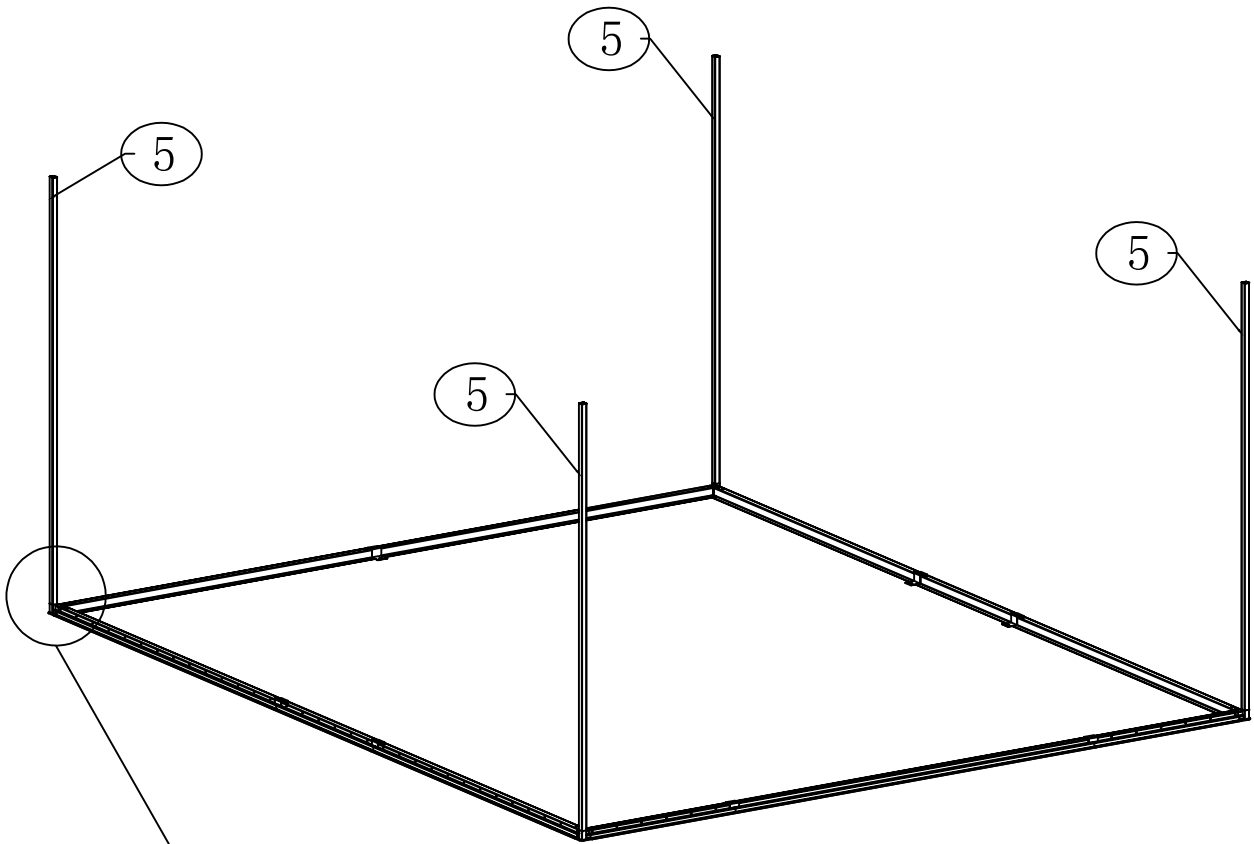







NO.	PART.	Qty.
5	 1610mm	4

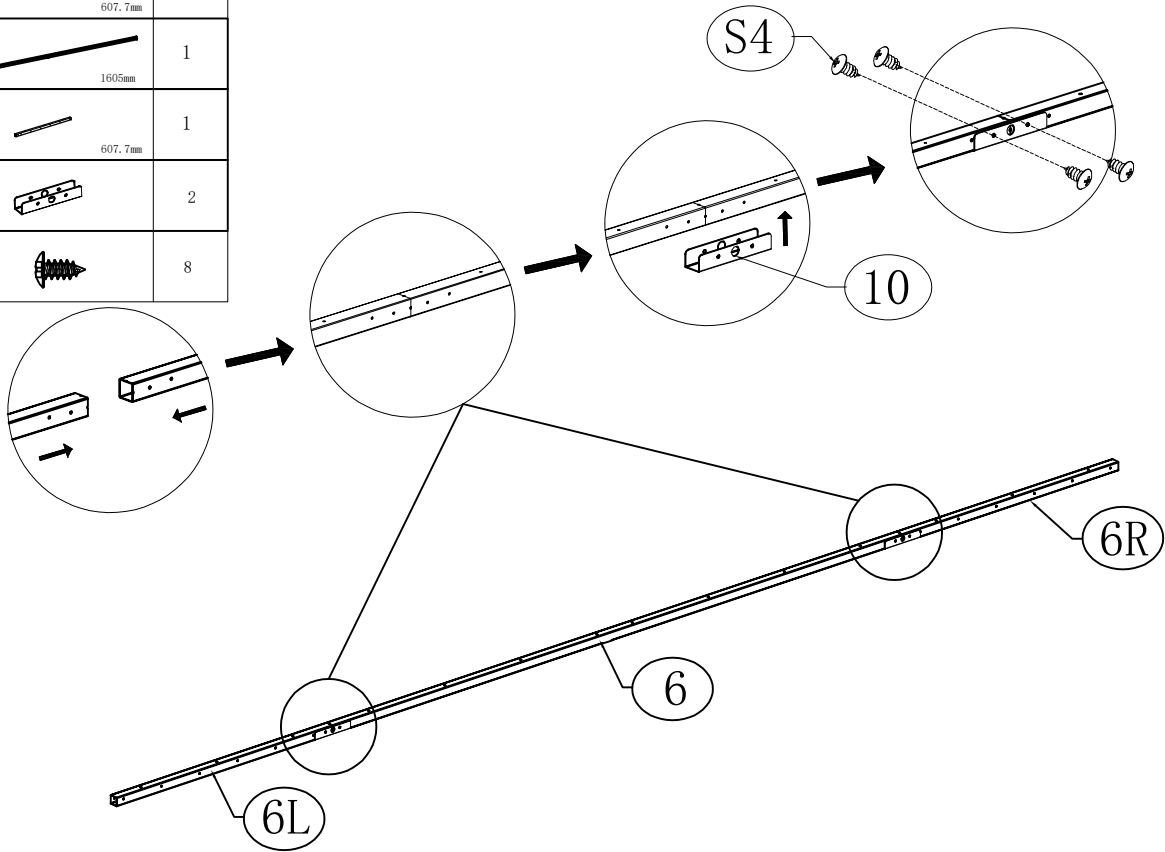





X4

NO.	PART.	Qty.
6L	 607.7mm	1
6	 1605mm	1
6R	 607.7mm	1
10		2
S4		8

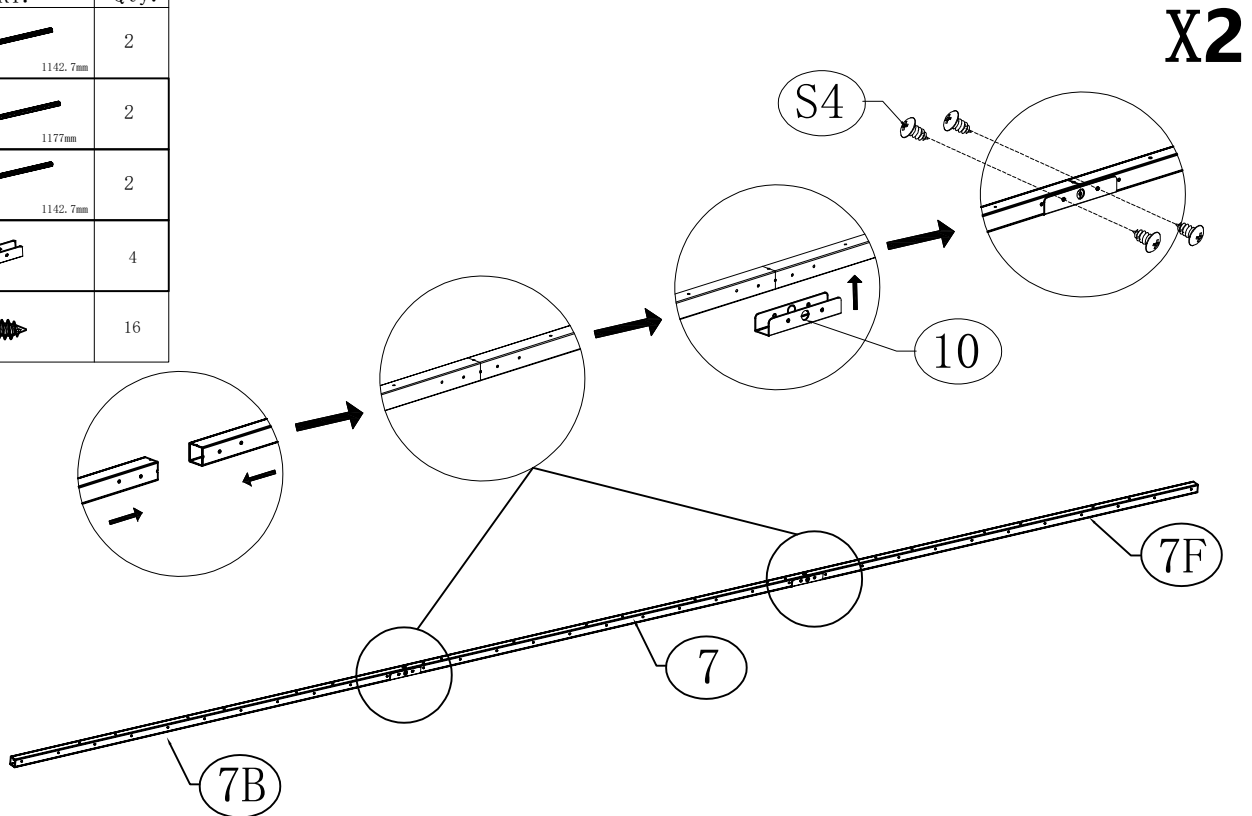



NO.	PART.	Qty.
7F	 1142.7mm	2
7	 1177mm	2
7B	 1142.7mm	2
10		4
S4		16



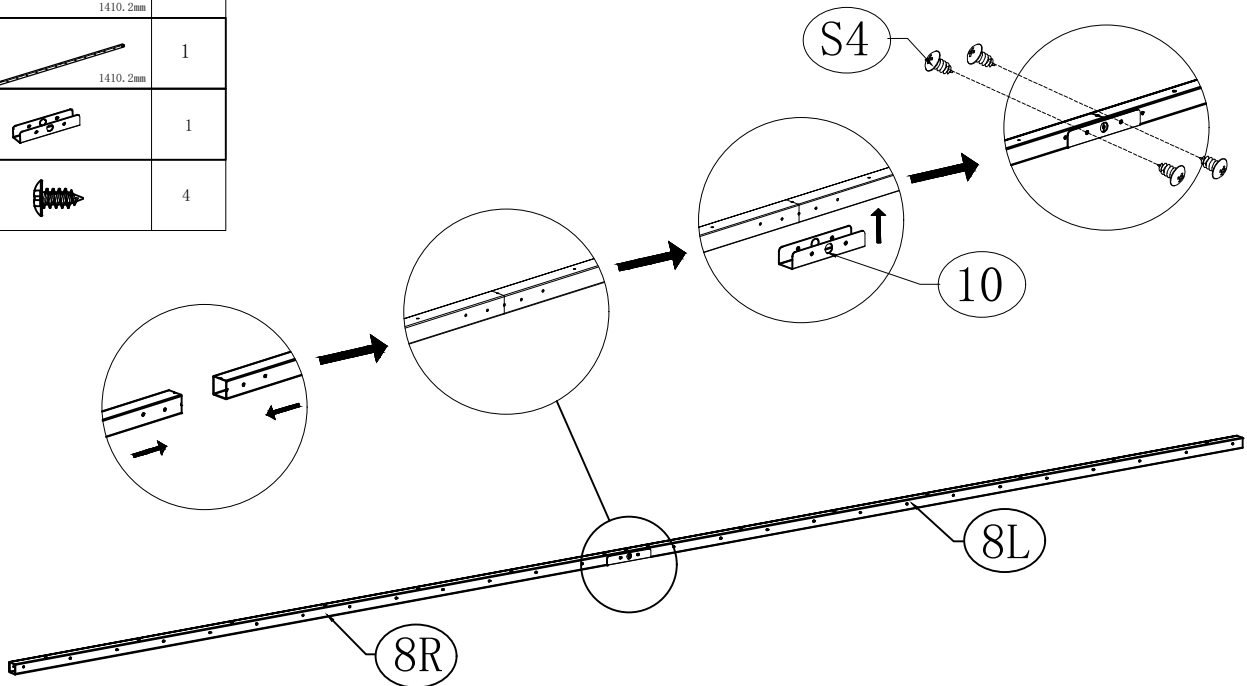

NO.	PART.	Qty.
8L	 1410, 2mm	1
8R	 1410, 2mm	1
10		1
S4		4



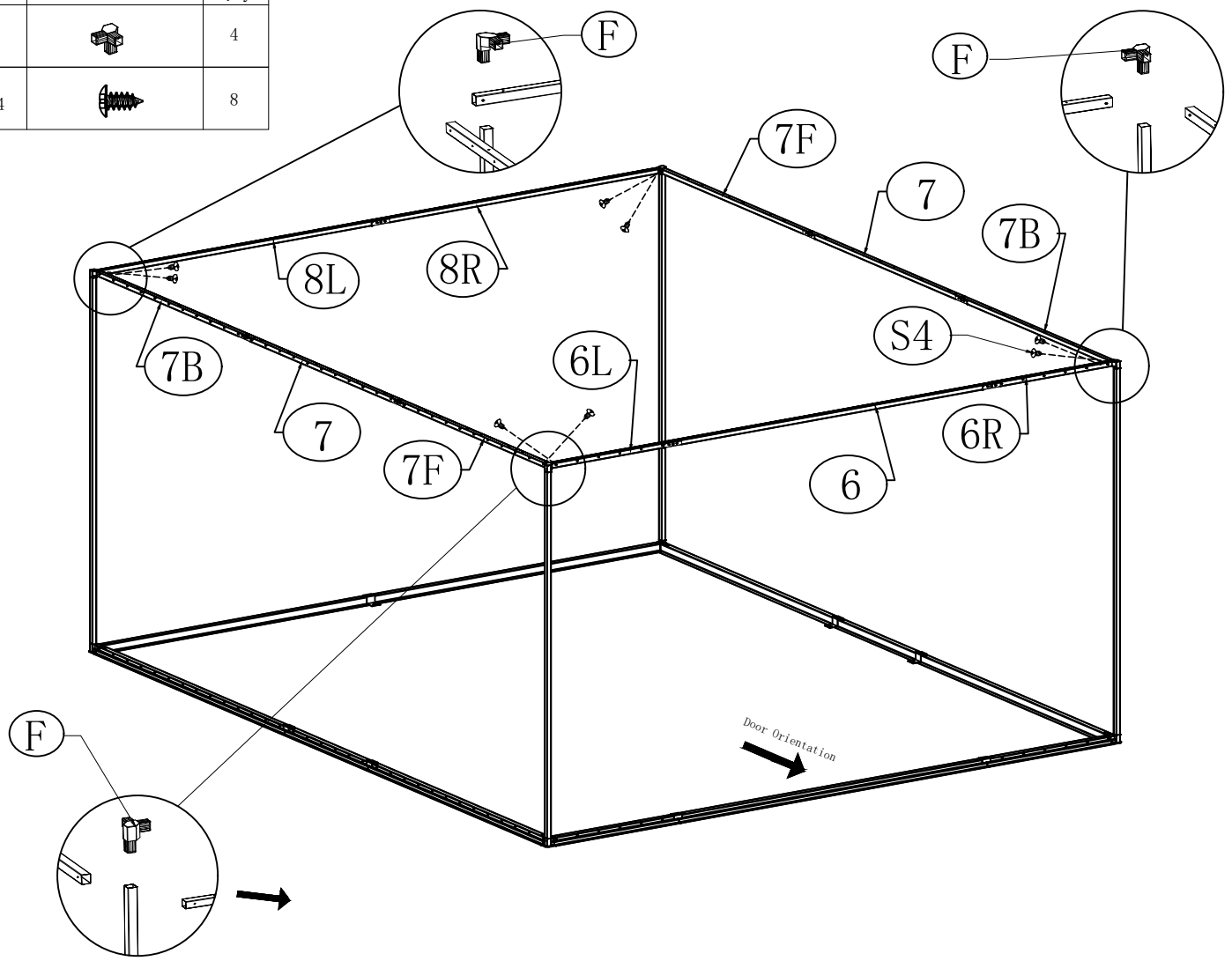

NO.	PART.	Qty.
F		4
S4		8



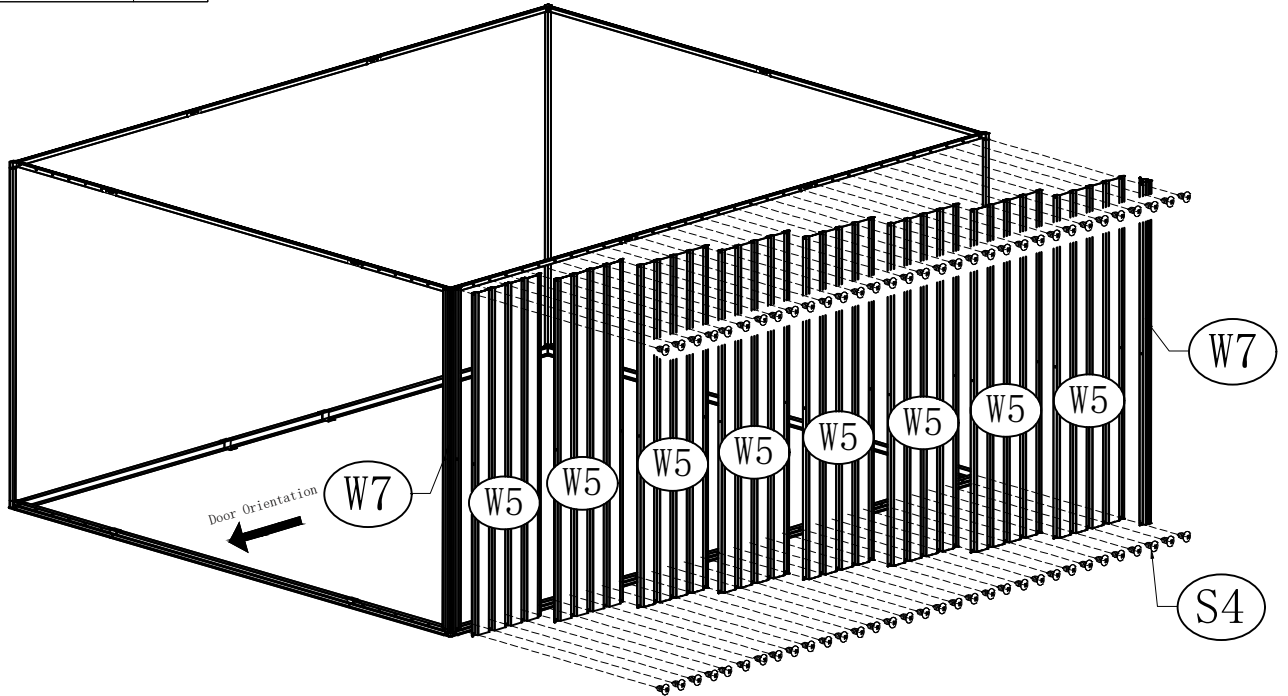



NO.	PART.	Qty.
W7	 1660mm	2
W5	 1660mm	8
S4		66

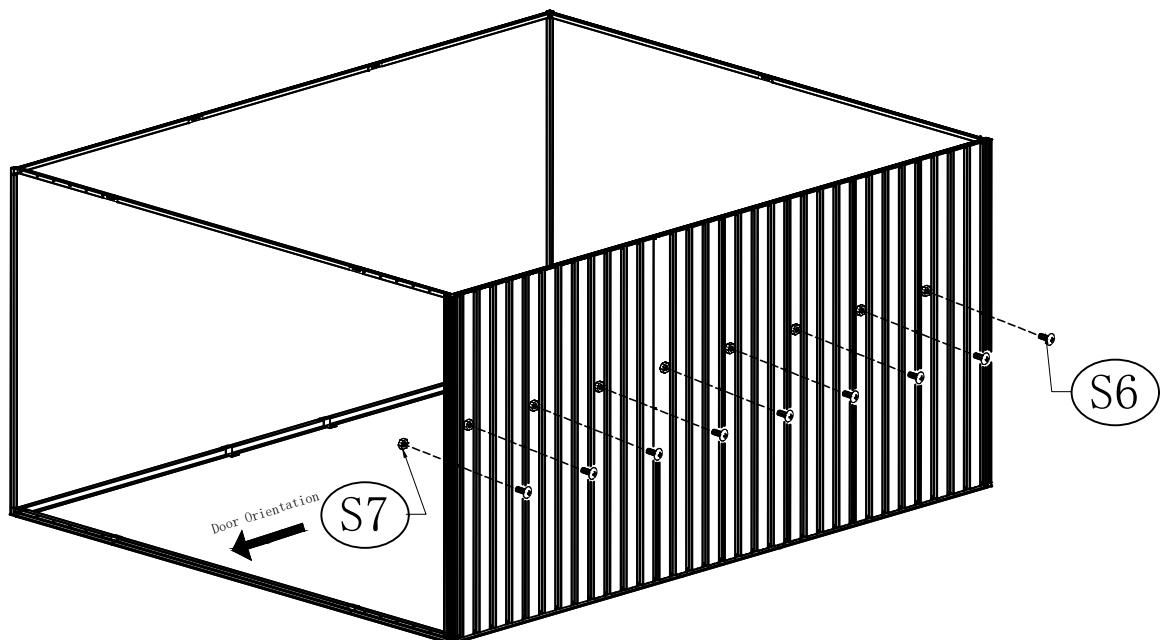

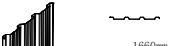

NO.	PART.	Qty.
S6		9
S7		9



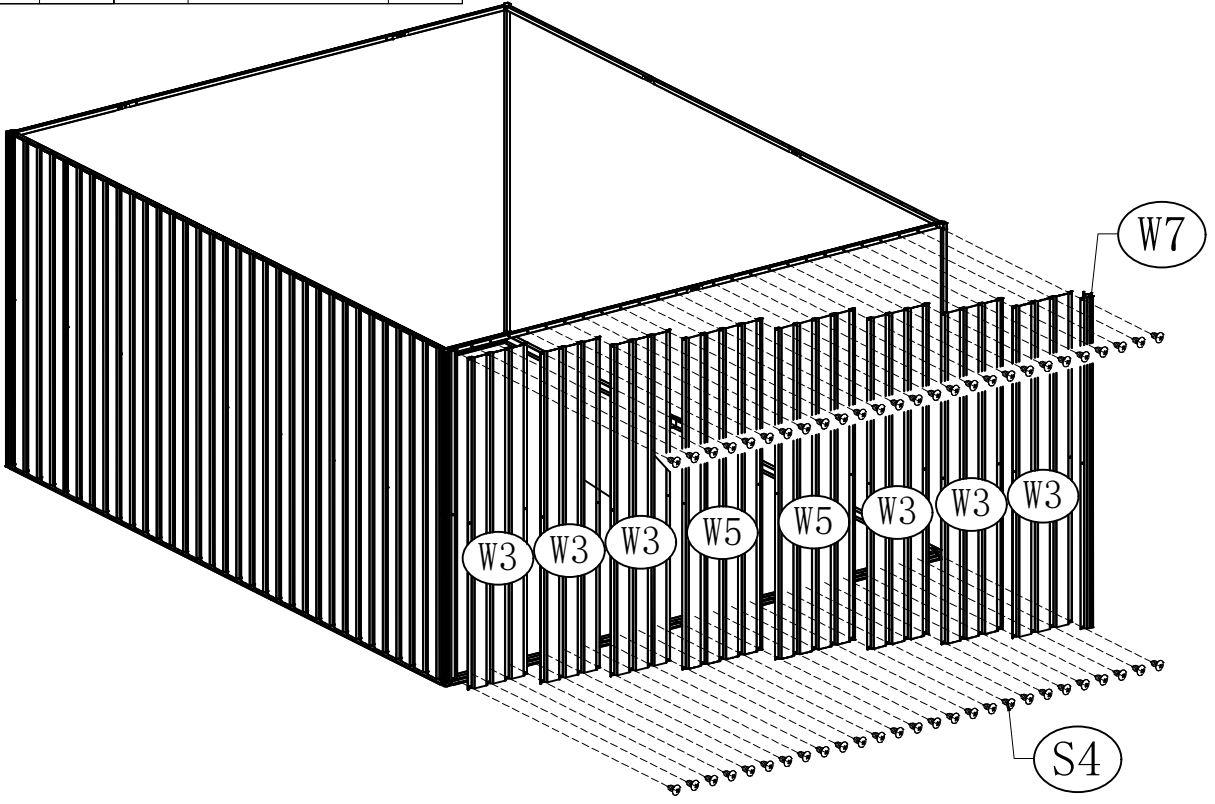



NO.	PART.	Qty.	NO.	PART.	Qty.
W7	 1660mm	1	W5	 1660mm	2
W3	 1660mm	6	S4		54

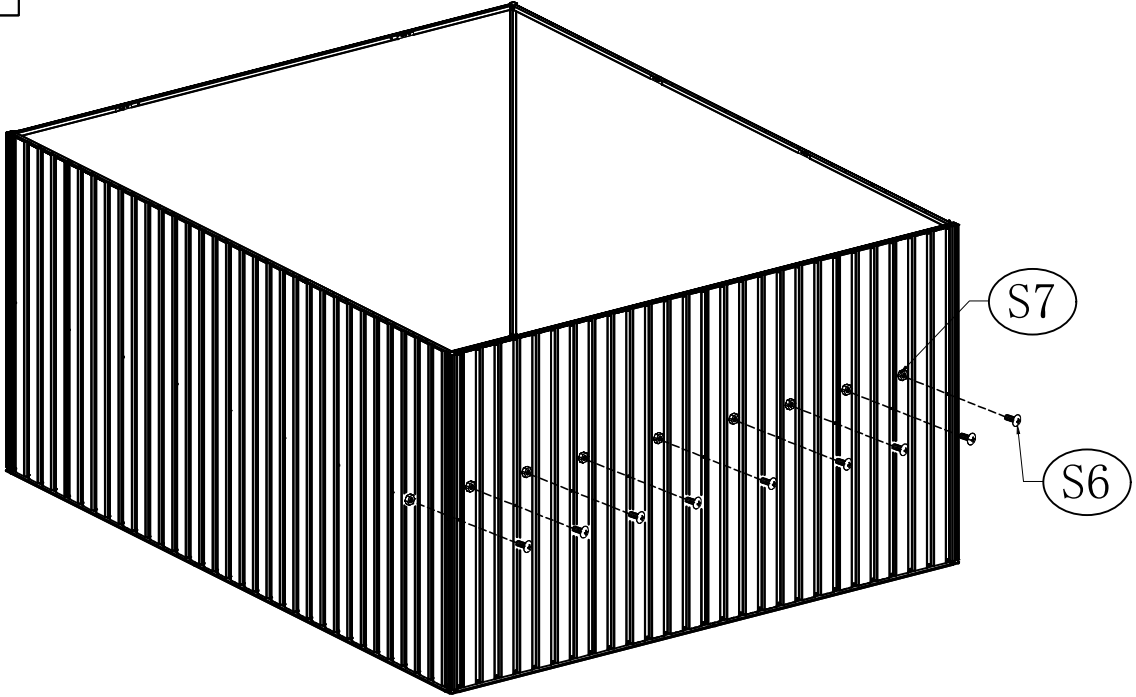



NO.	PART.	Qty.
S6		9
S7		9



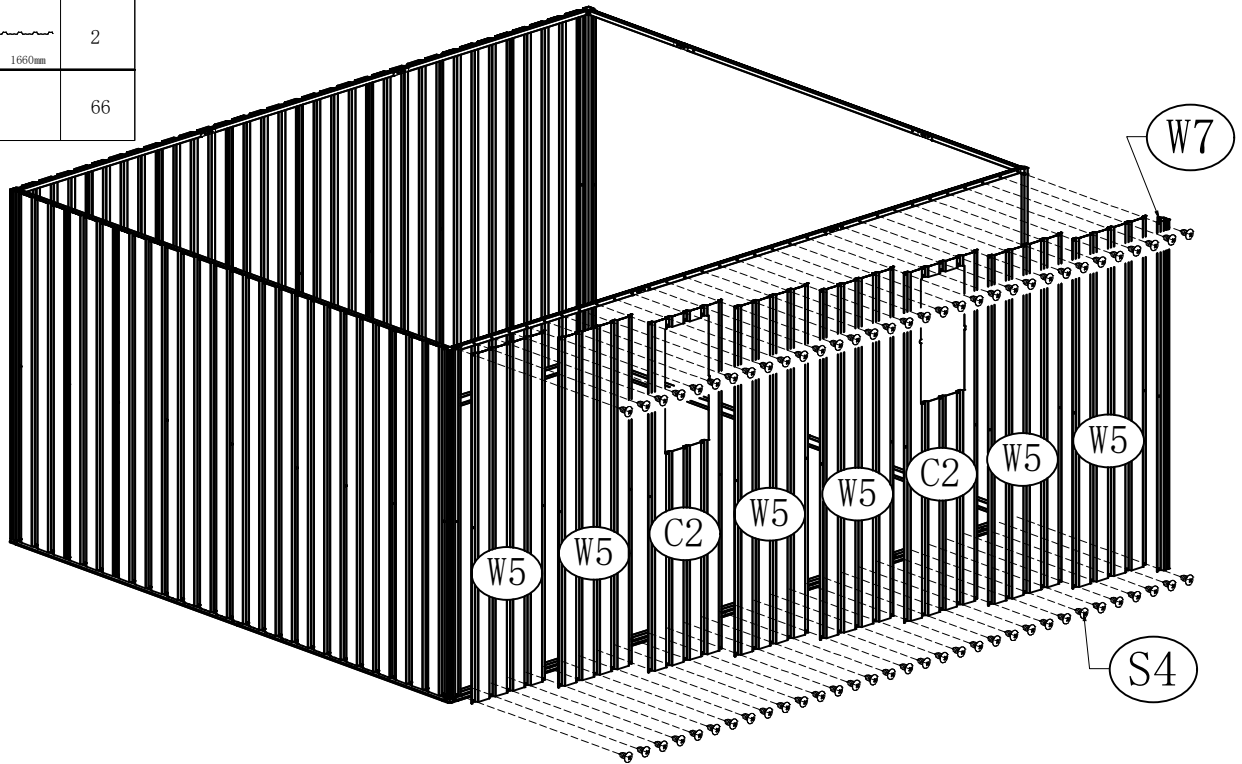

NO.	PART.	Qty.
W7	 1660mm	1
W5	 1660mm	6
C2	 1660mm	2
S4		66

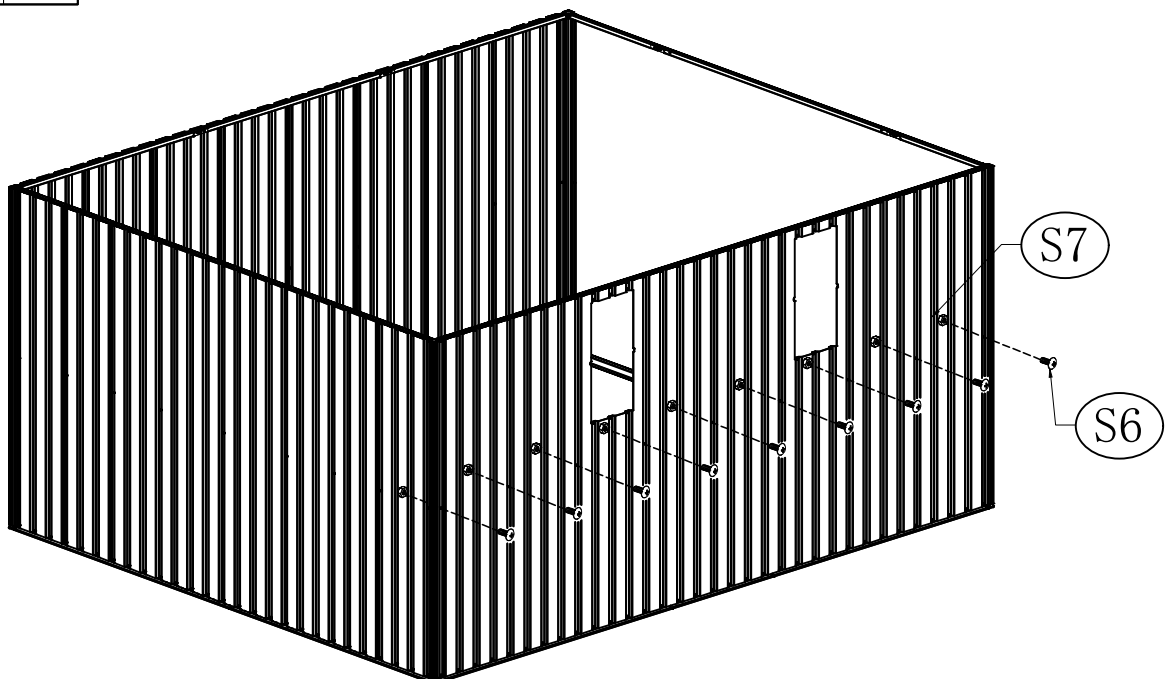

NO.	PART.	Qty.
S6		9
S7		9

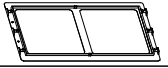
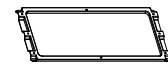
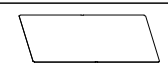

NO.	PART.	Qty.
F12		2
F13		2
F14		2
S4		16

X2

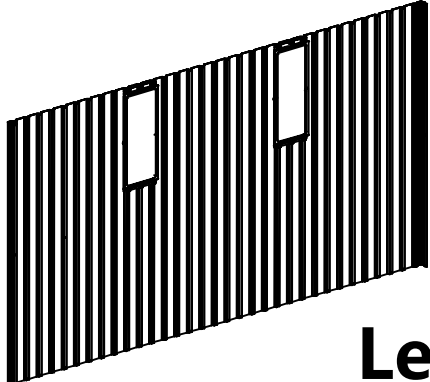
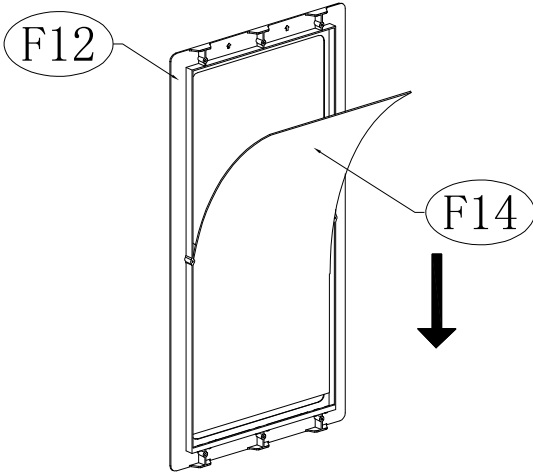
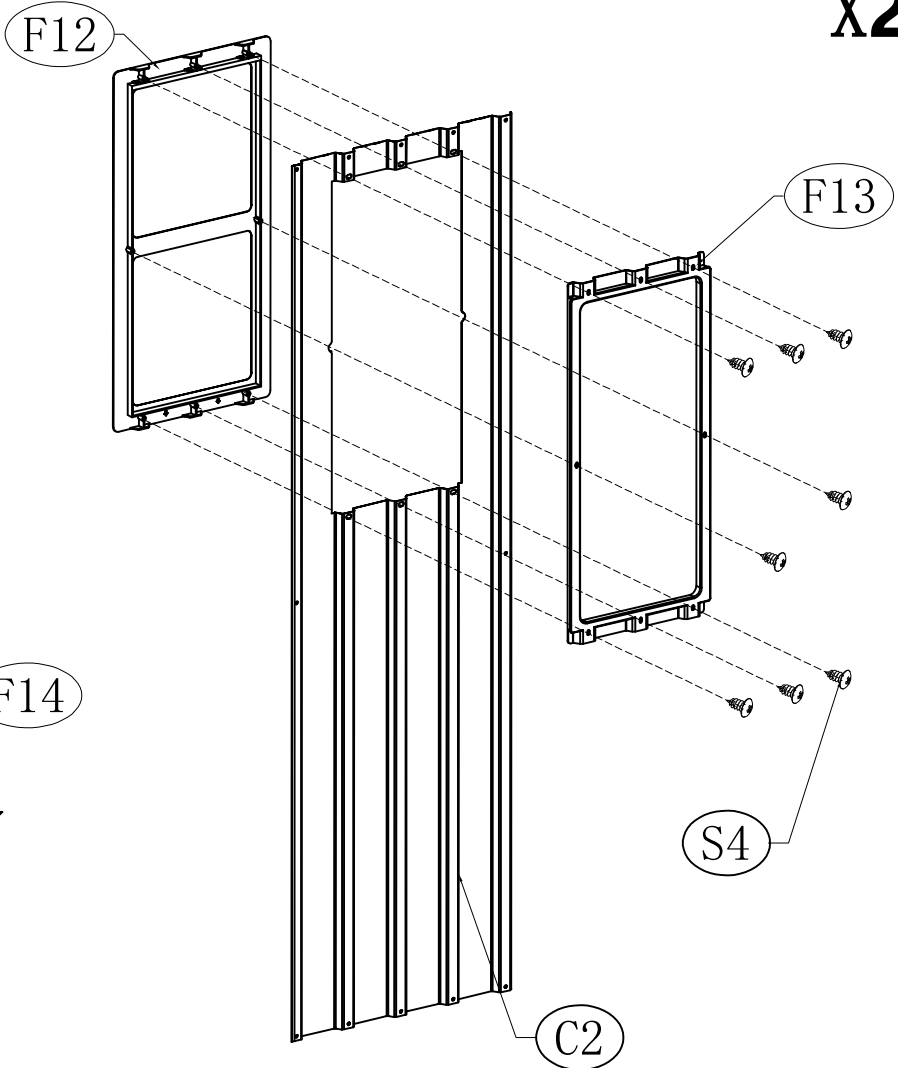





Left

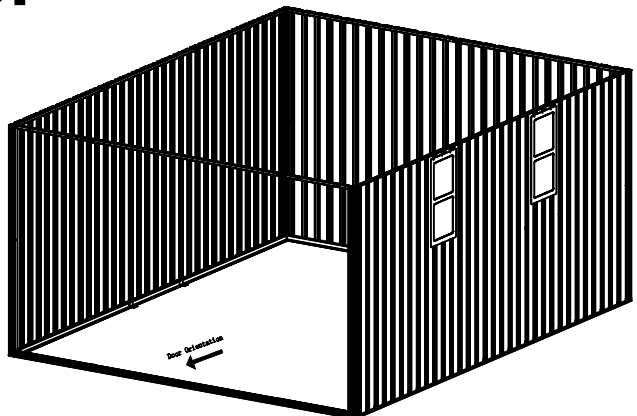
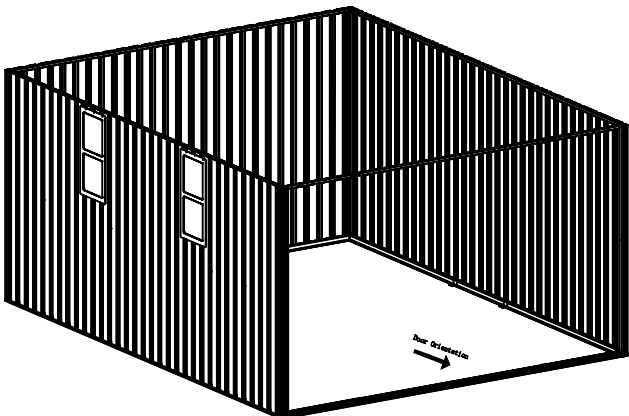

or

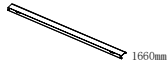
Right



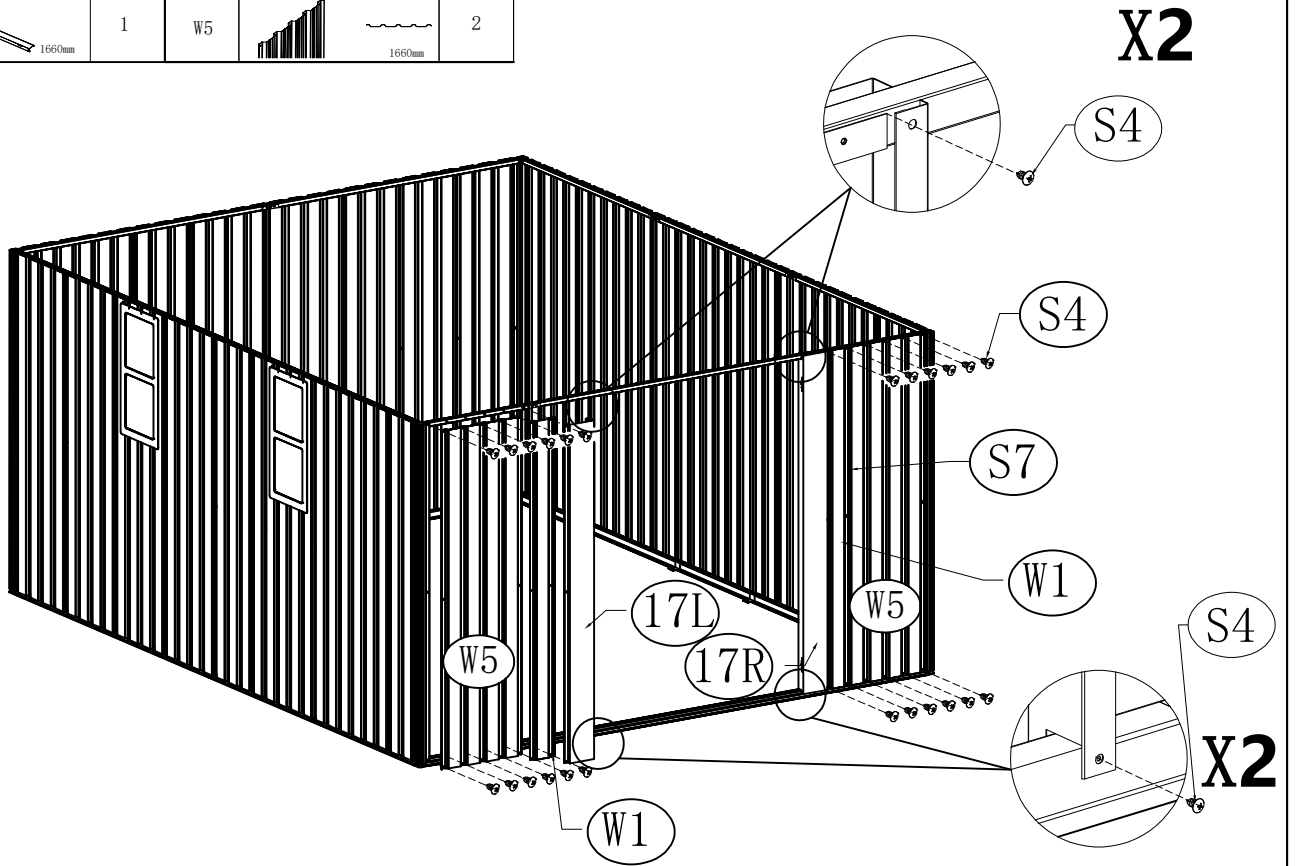



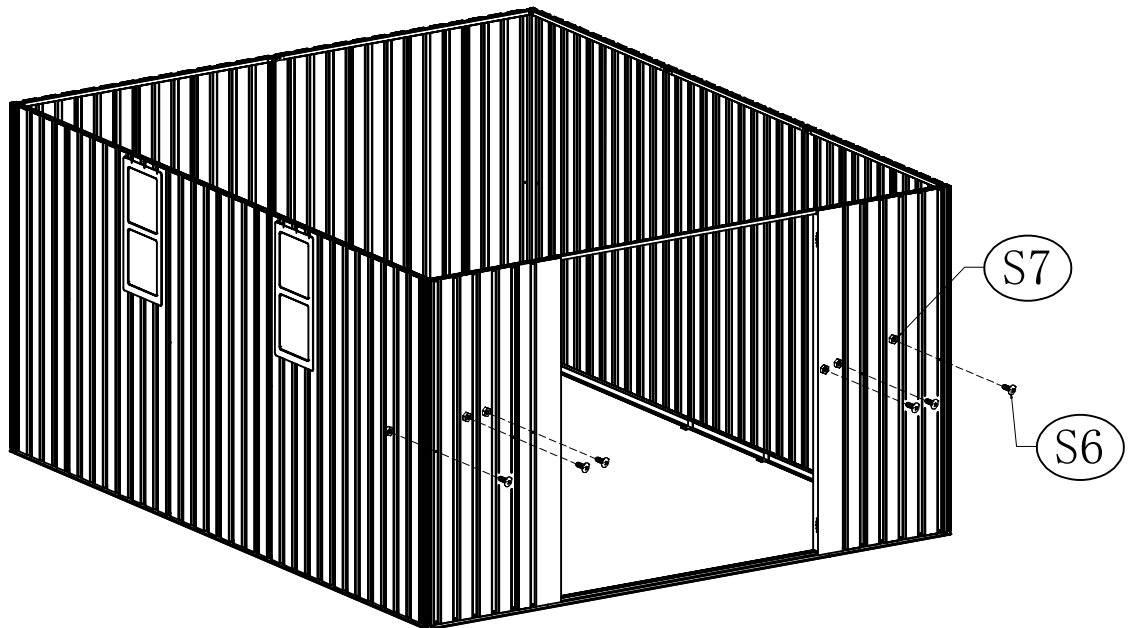

NO.	PART.	Qty.	NO.	PART.	Qty.	NO.	PART.	Qty.
17L		1	W1		2	S4		28
17R		1	W5		2			



NO.	PART.	Qty.
S6		6
S7		6



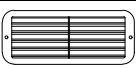

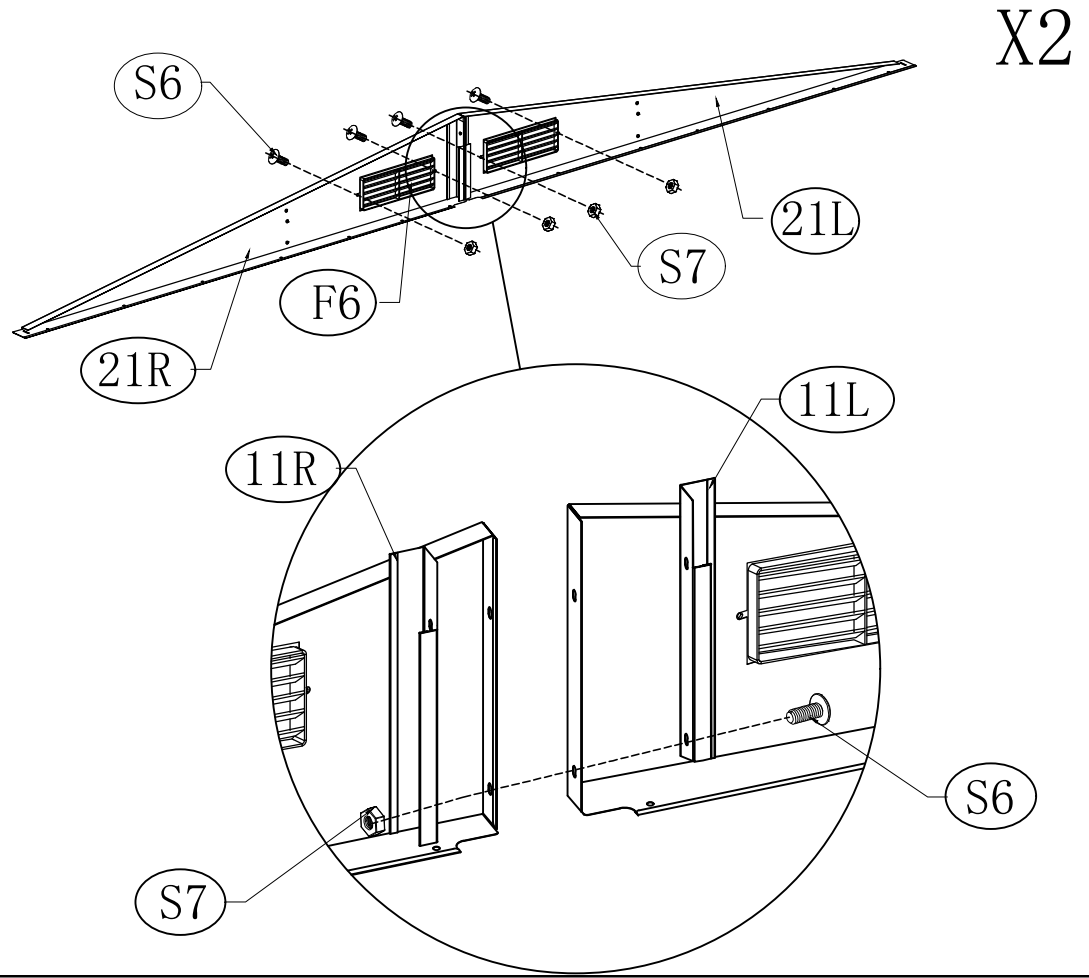

NO.	PART.	Qty.
11L	 320mm	2
11R	 320mm	2
21L		2
21R		2
S6		10
S7		10
F6		4

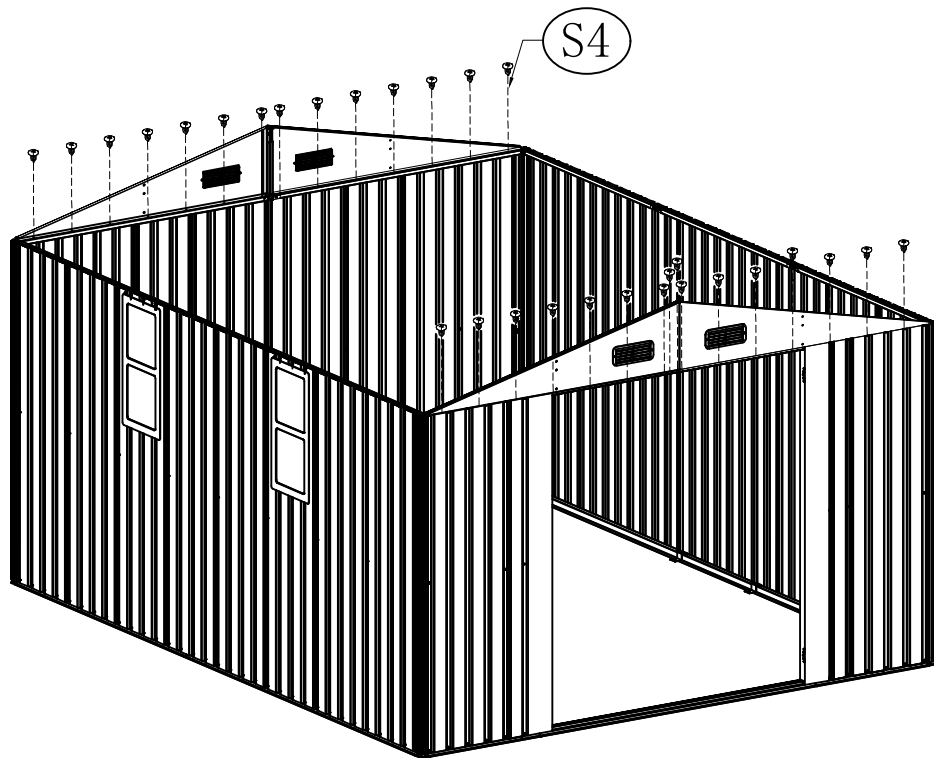



NO.	PART.	Qty.
S4		30



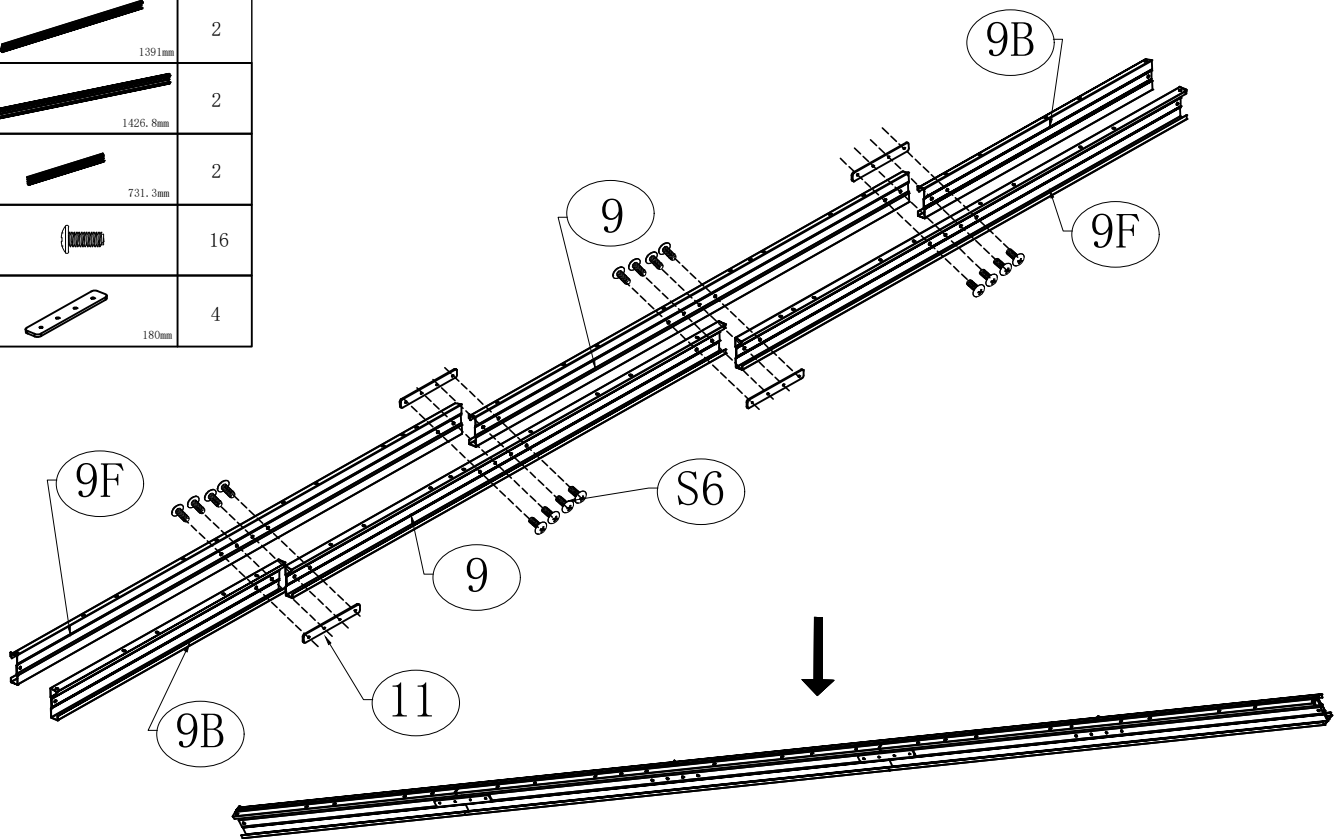



NO.	PART.	Qty.
9	 1391mm	2
9F	 1426.8mm	2
9B	 731.3mm	2
S6		16
11	 180mm	4

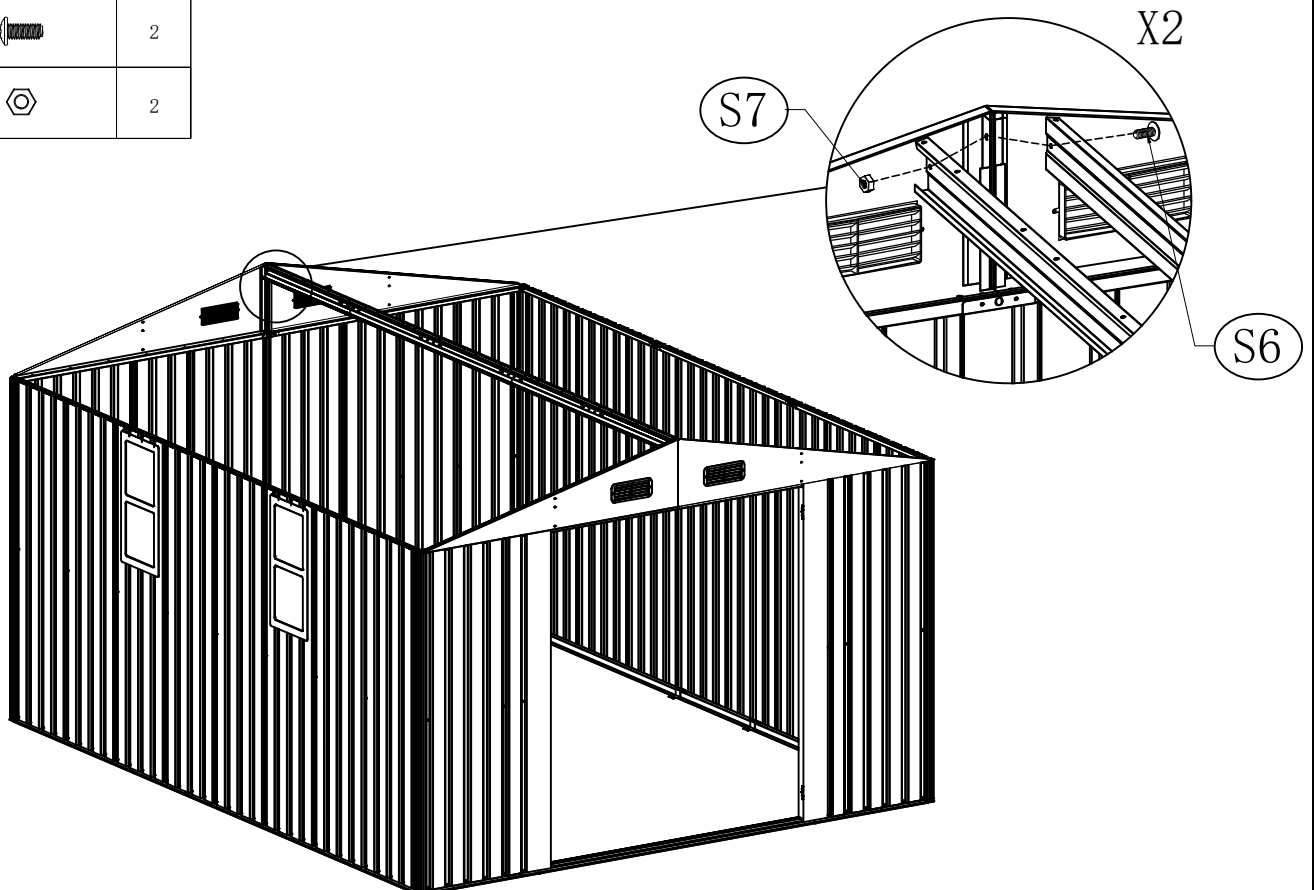

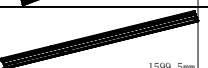

NO.	PART.	Qty.
S6		2
S7		2



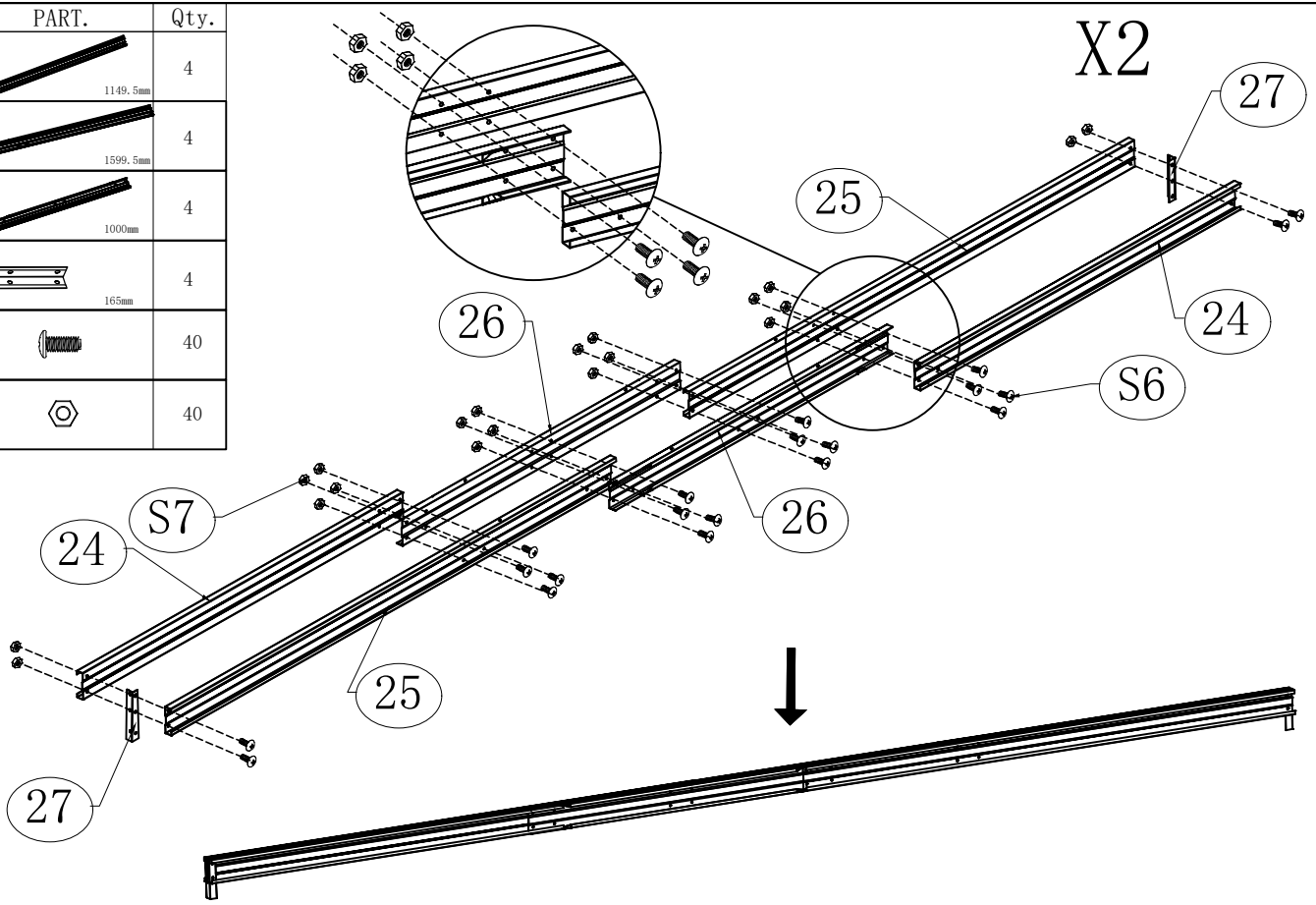

NO.	PART.	Qty.
24	 1149.5mm	4
25	 1599.5mm	4
26	 1000mm	4
27	 165mm	4
S6		40
S7		40



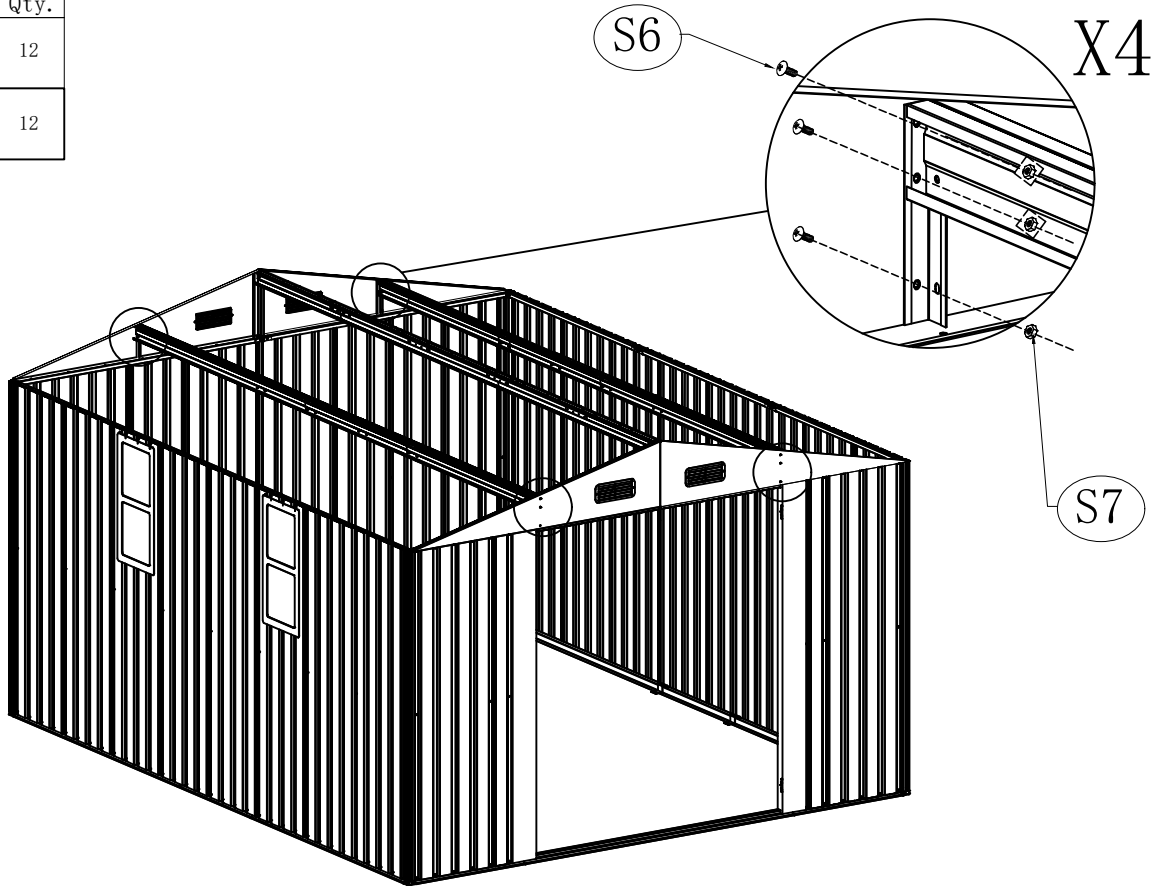

NO.	PART.	Qty.
S6		12
S7		12



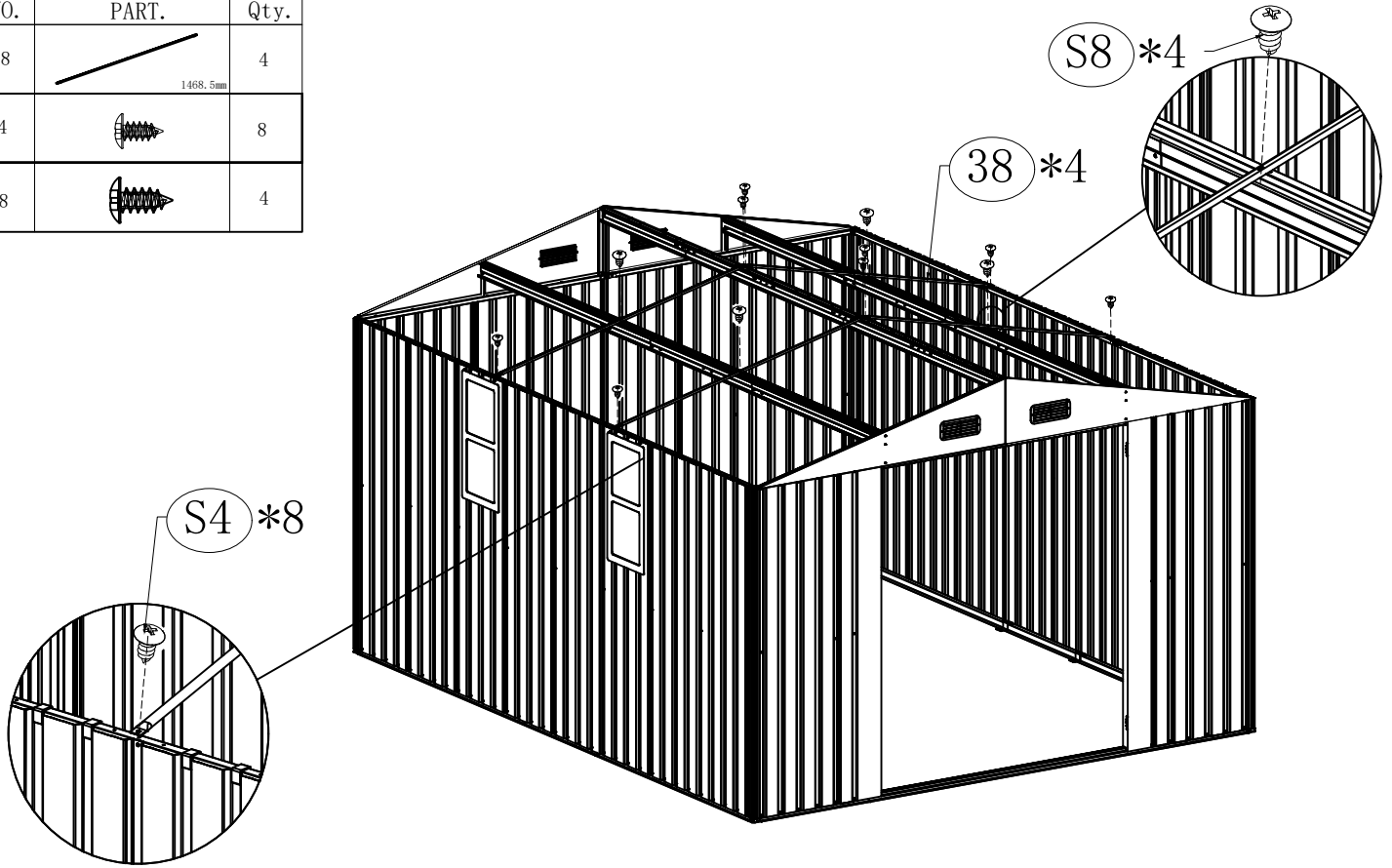





NO.	PART.	Qty.
38	 1468, 5mm	4
S4		8
S8		4

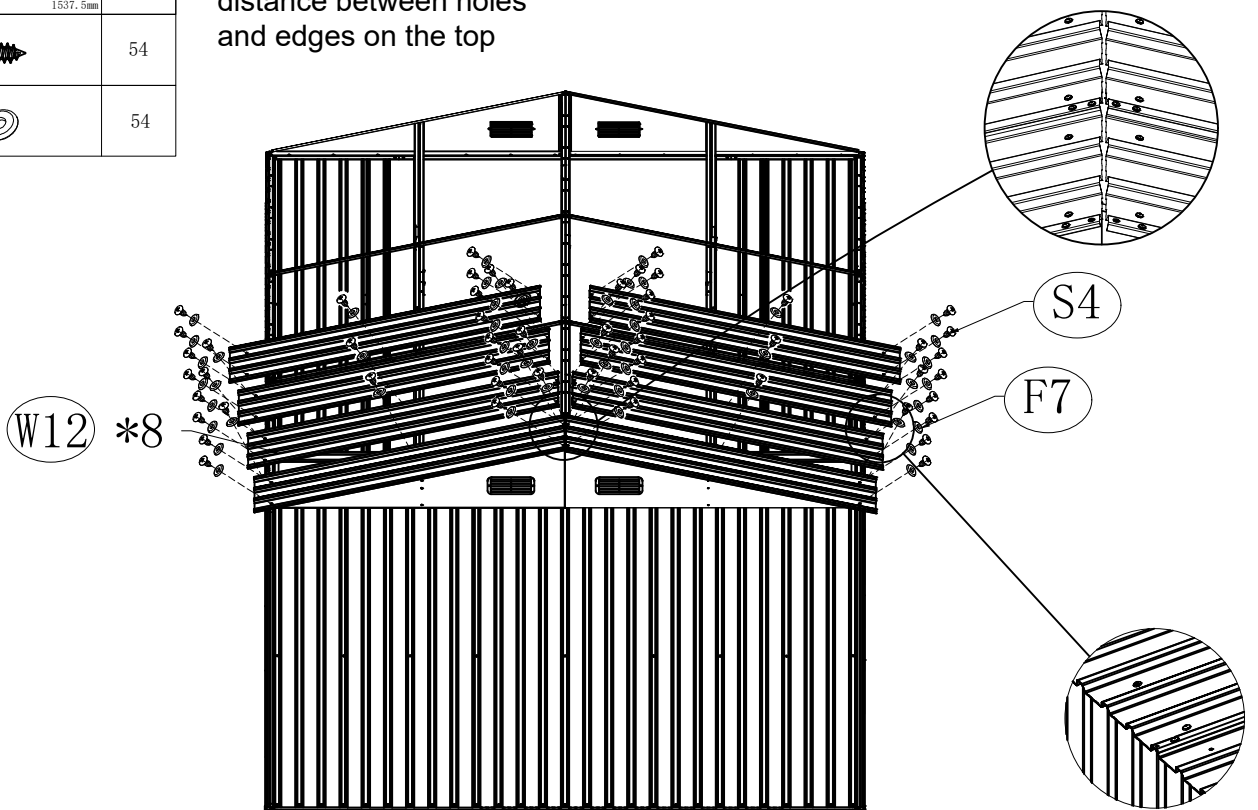

NO.	PART.	Qty.
W12	 1537, 5mm	8
S4		54
F7		54





Place the side with small distance between holes and edges on the top

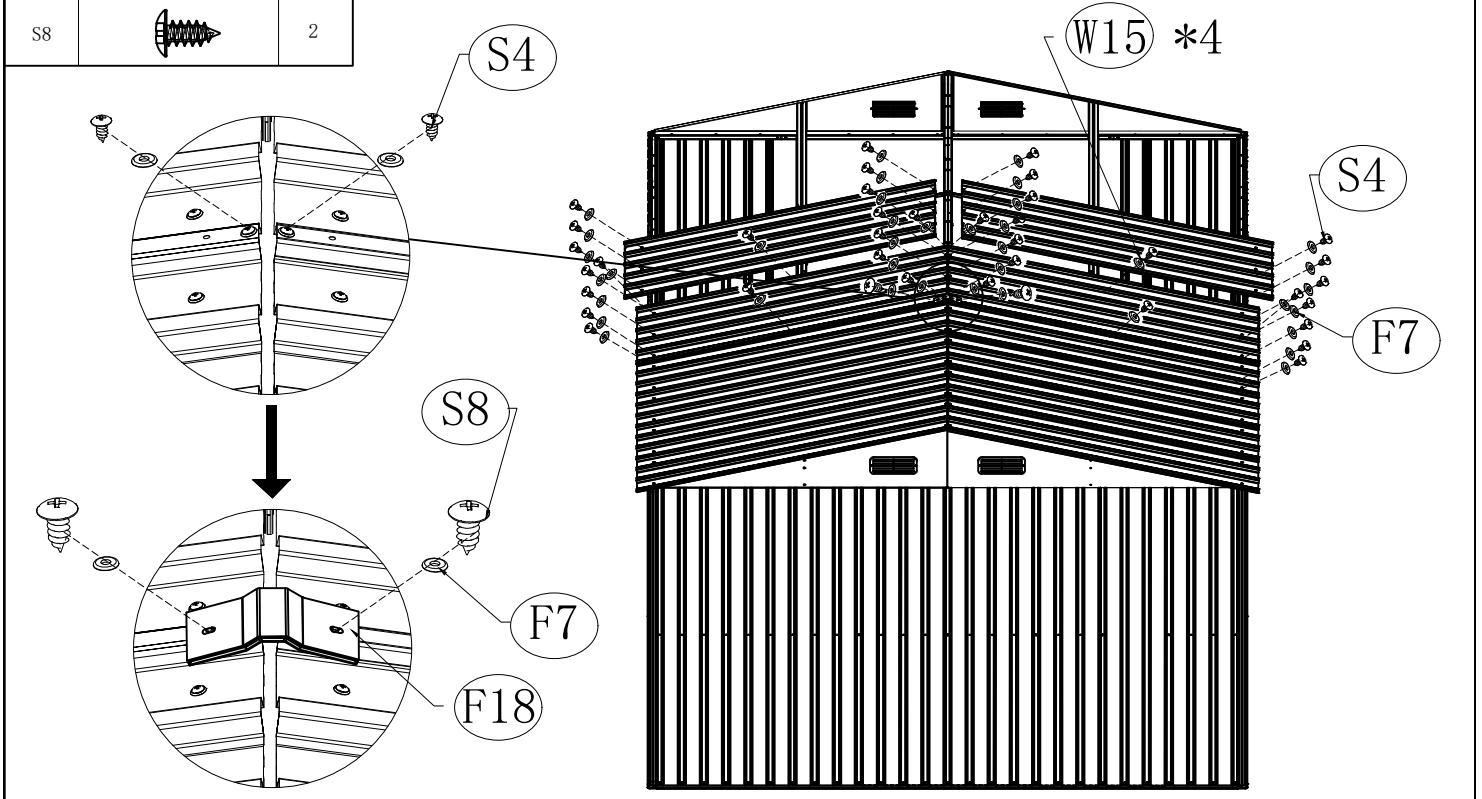

NO.	PART.	Qty.	NO.	PART.	Qty.
W15		4	F7		38
S4		36	F18		1
S8		2			



Place the side with small distance between holes and edges on the top



NO.	PART.	Qty.	NO.	PART.	Qty.
W12		2	F7		18
S4		16	F18		1
S8		2	18B		1

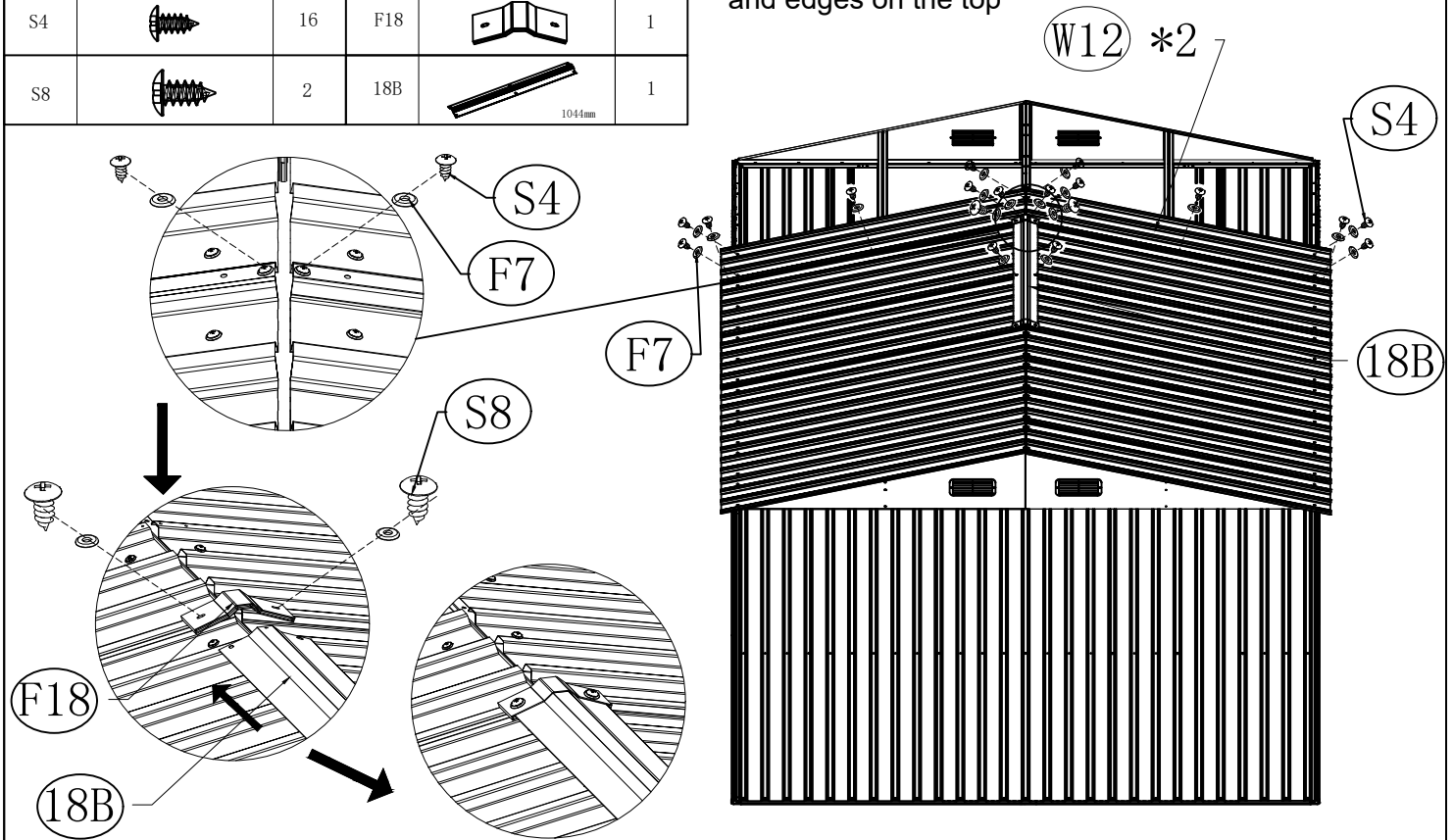





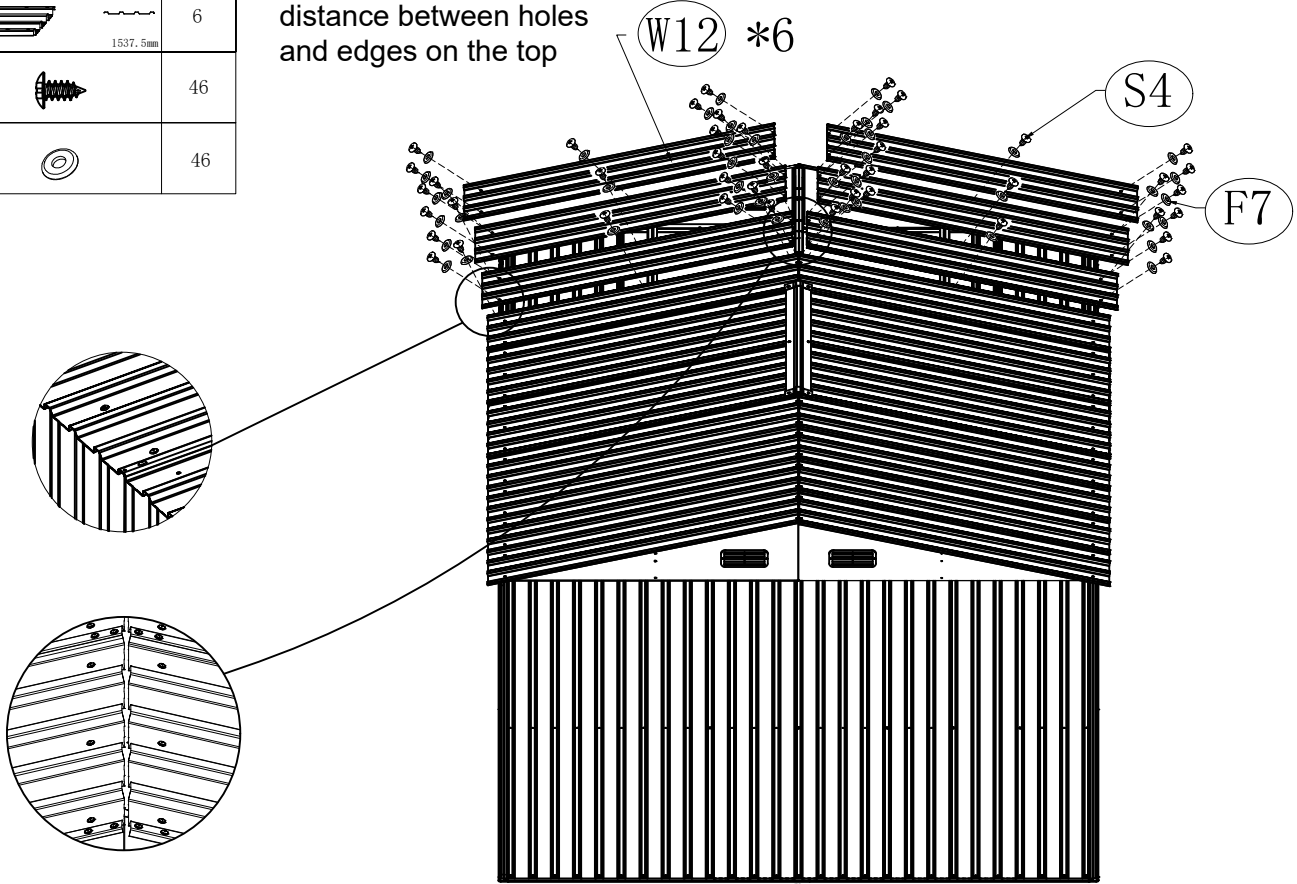

Place the side with small distance between holes and edges on the top





NO.	PART.	Qty.
W12	 1537.5mm	6
S4		46
F7		46

Place the side with small distance between holes and edges on the top



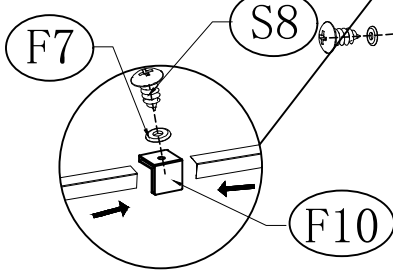
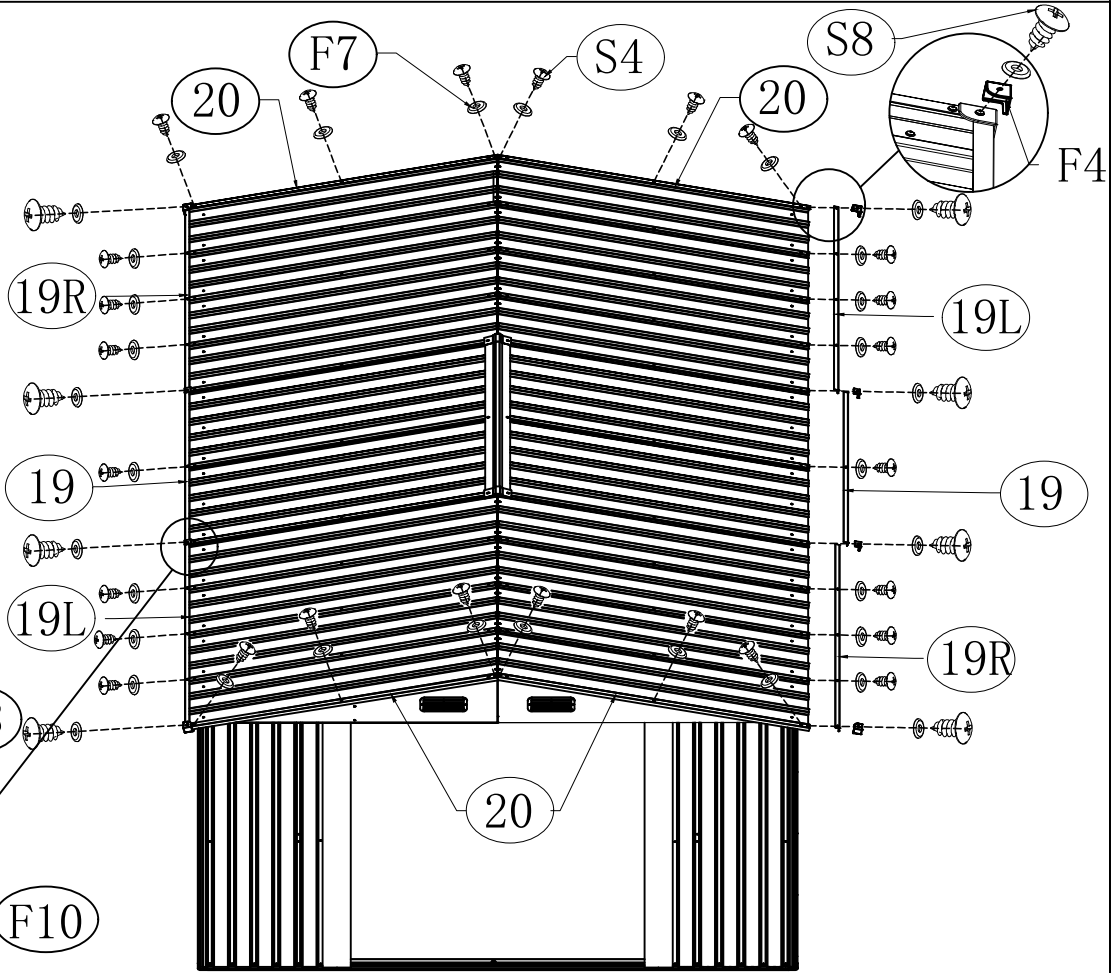



NO.	PART.	Qty.
19L	 1274mm	2
19	 1044mm	2
19R	 1274mm	2
20	 1545.5mm	4
S4		26
S8		8
F4		4
F7		34
F10		4

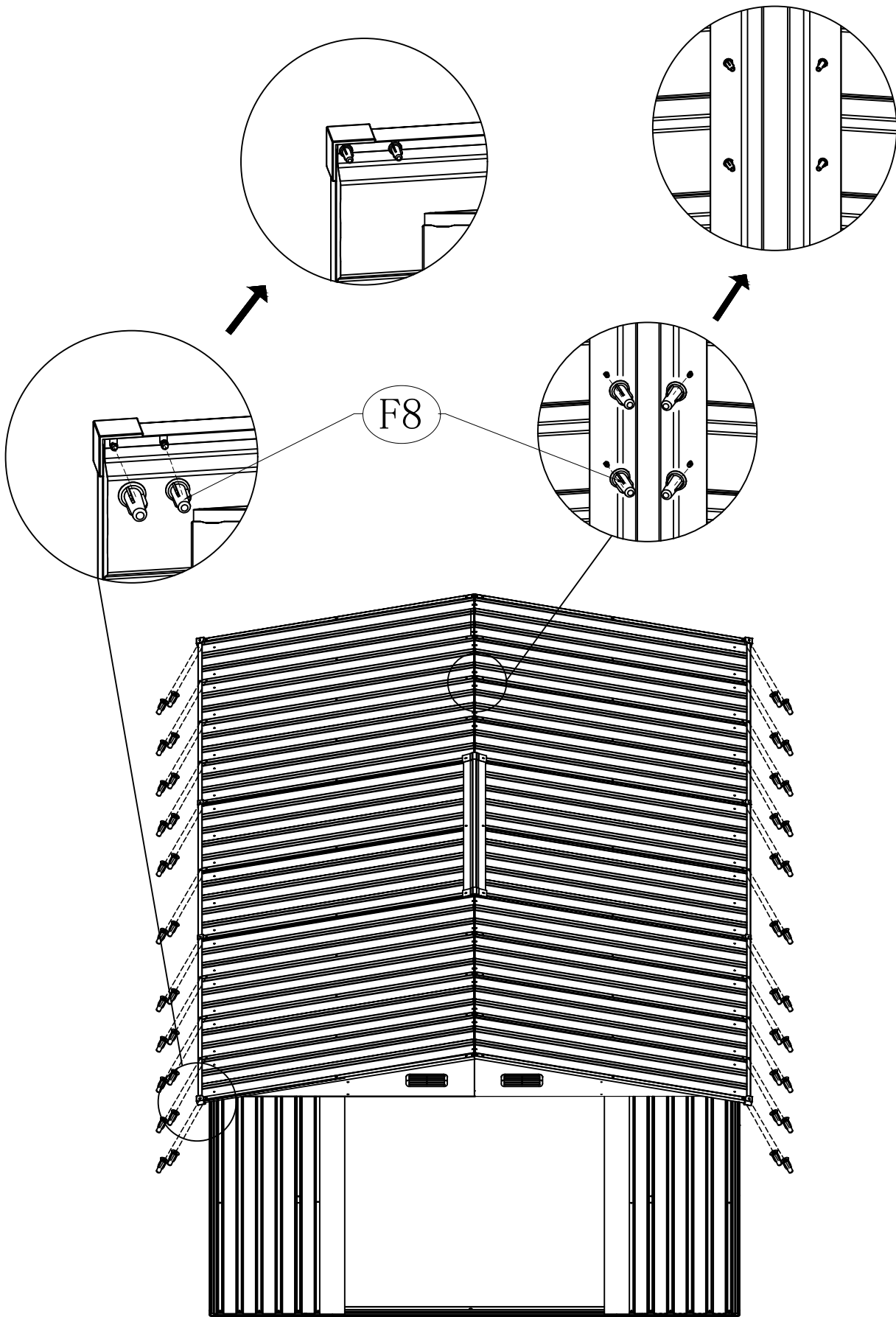





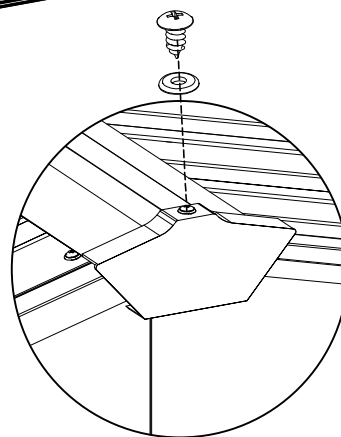
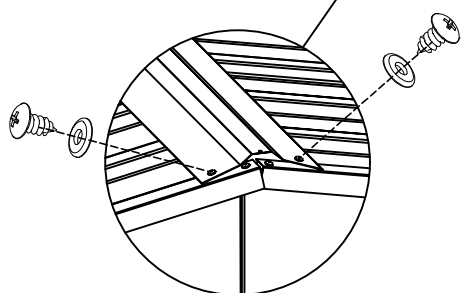
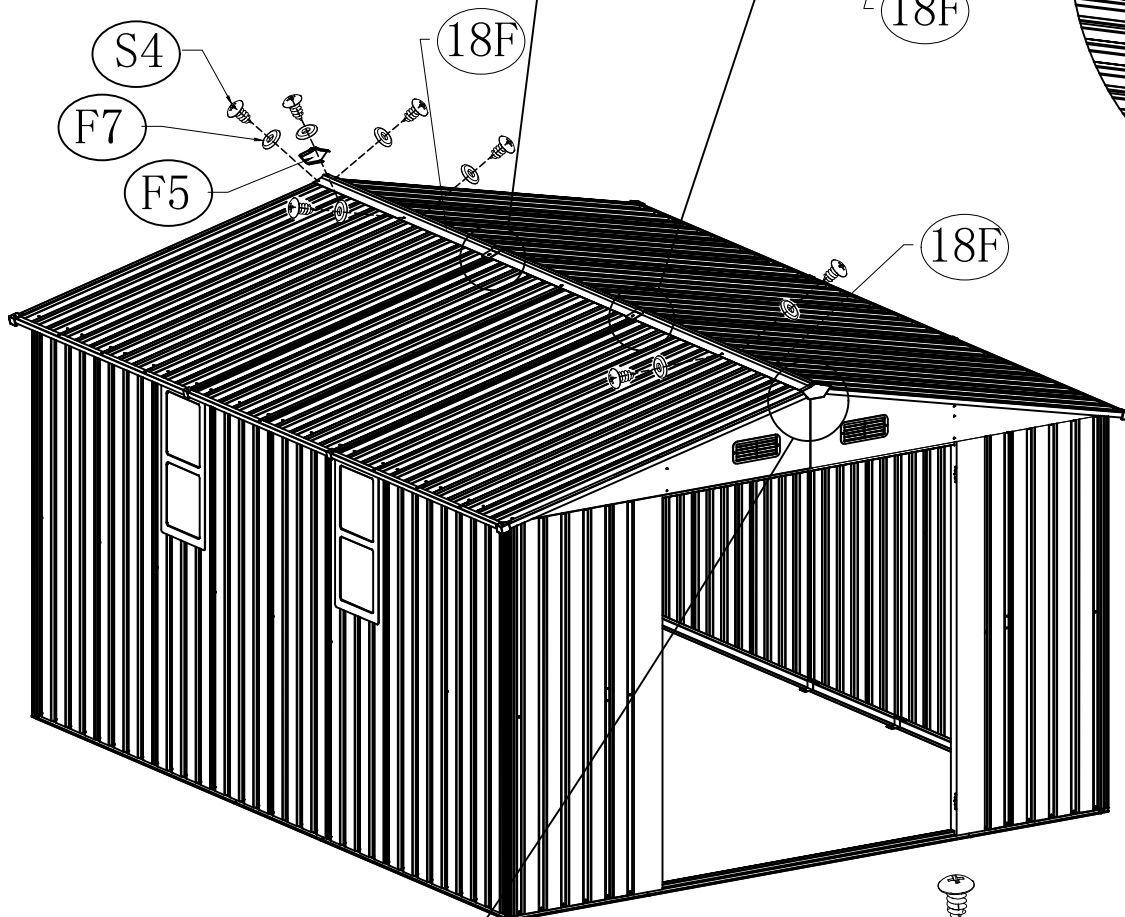
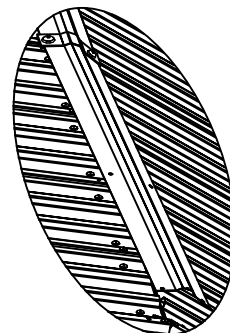
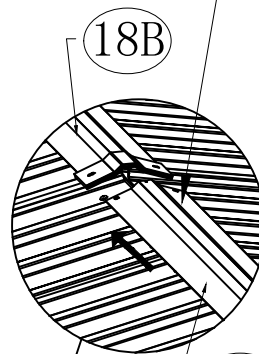
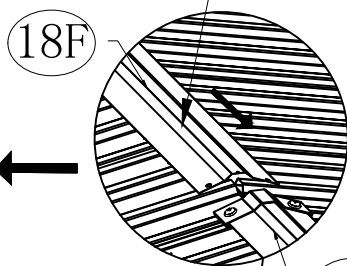
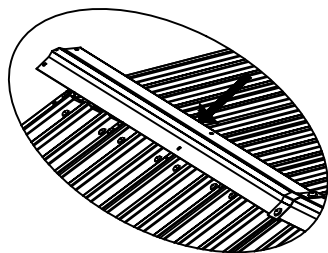
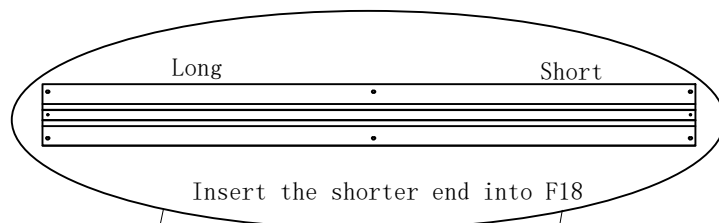

NO.	PART.	Qty.
F8		110

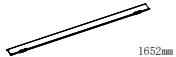
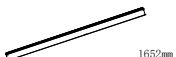



NO.	PART.	Qty.
18F	 1274mm	2
F5		2
S4		10
F7		10



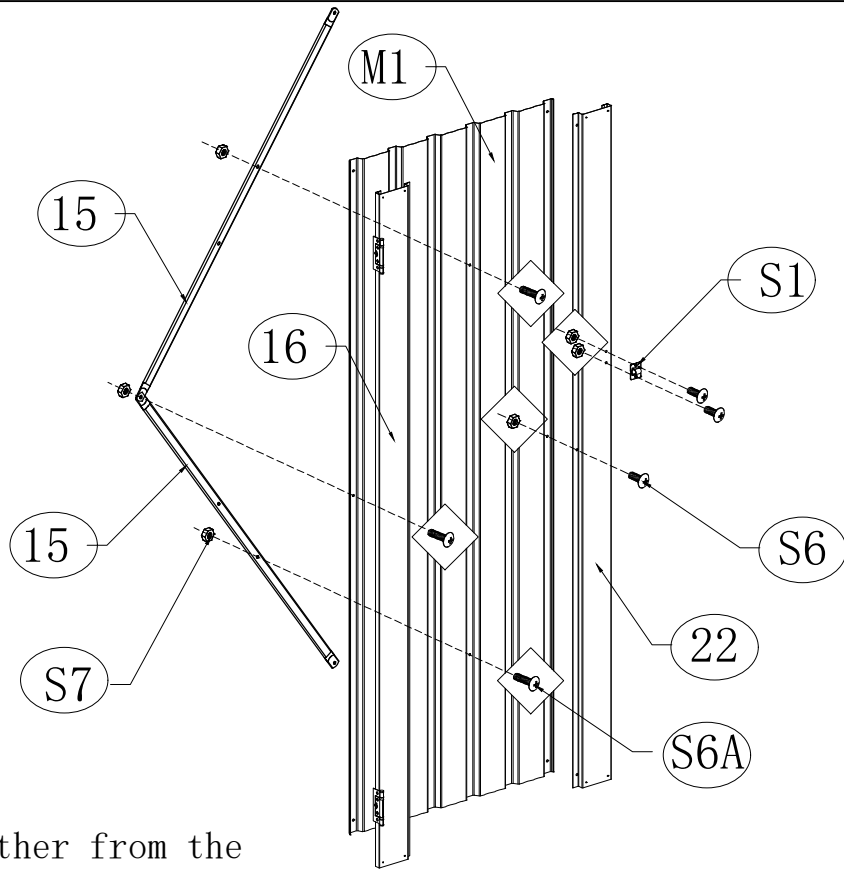



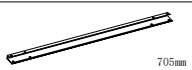

NO.	PART.	Qty.
15	 980.7mm	2
16	 1652mm	1
22	 1652mm	1
M1	 1650mm	1
S1		1
S6		3
S6A		3
S7		6

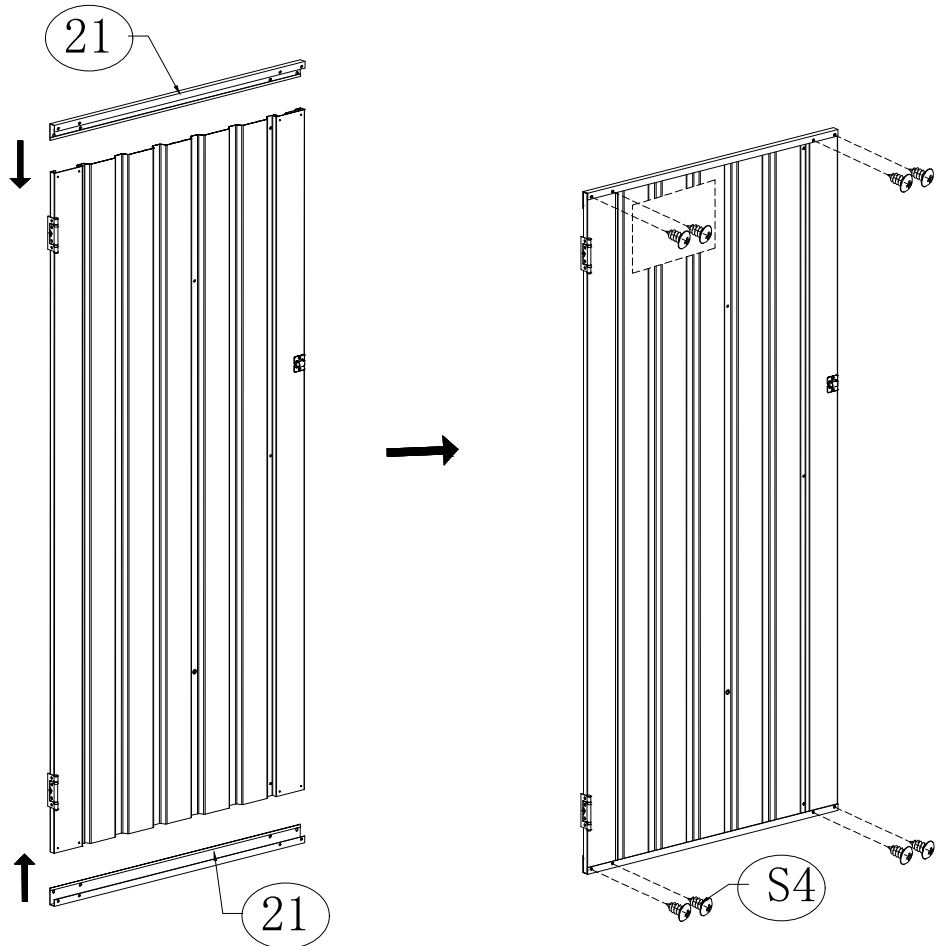



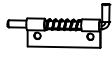
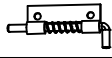





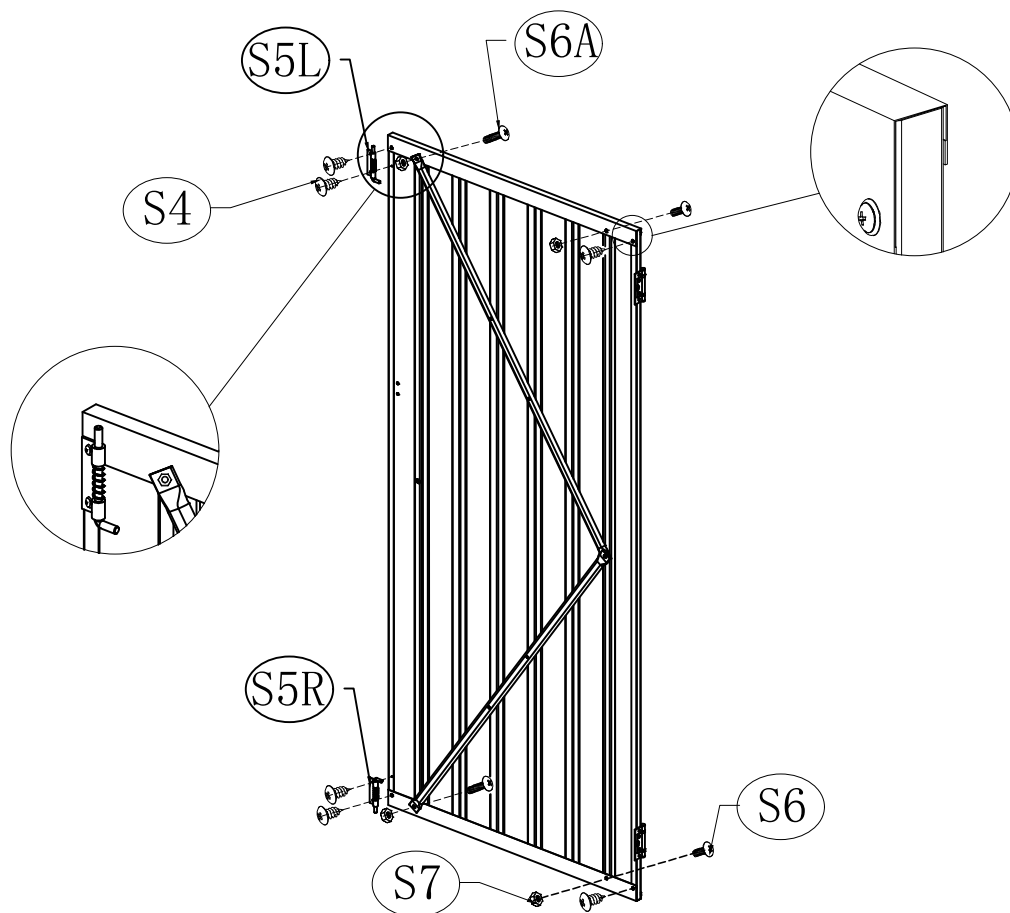

Put 16 on the side farther from the hole in the center of the tile and 22 on the side nearer.

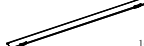
NO.	PART.	Qty.
21	 705mm	2
S4		8





NO.	PART.	Qty.
S4		6
S5L		1
S5R		1
S6		2
S6A		2
S7		4



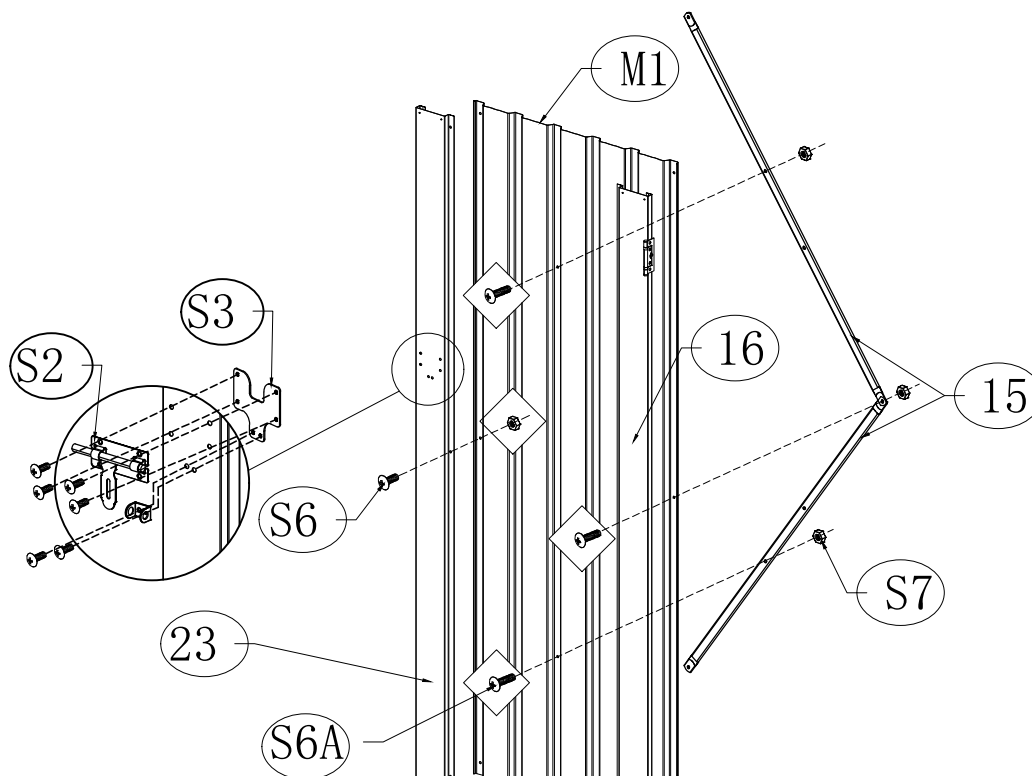



NO.	PART.	Qty.
15	 980.7mm	2
16	 1652mm	1
23	 1652mm	1
M1	 1650mm	1
S2		1
S3		1
S6		7
S6A		3
S7		4



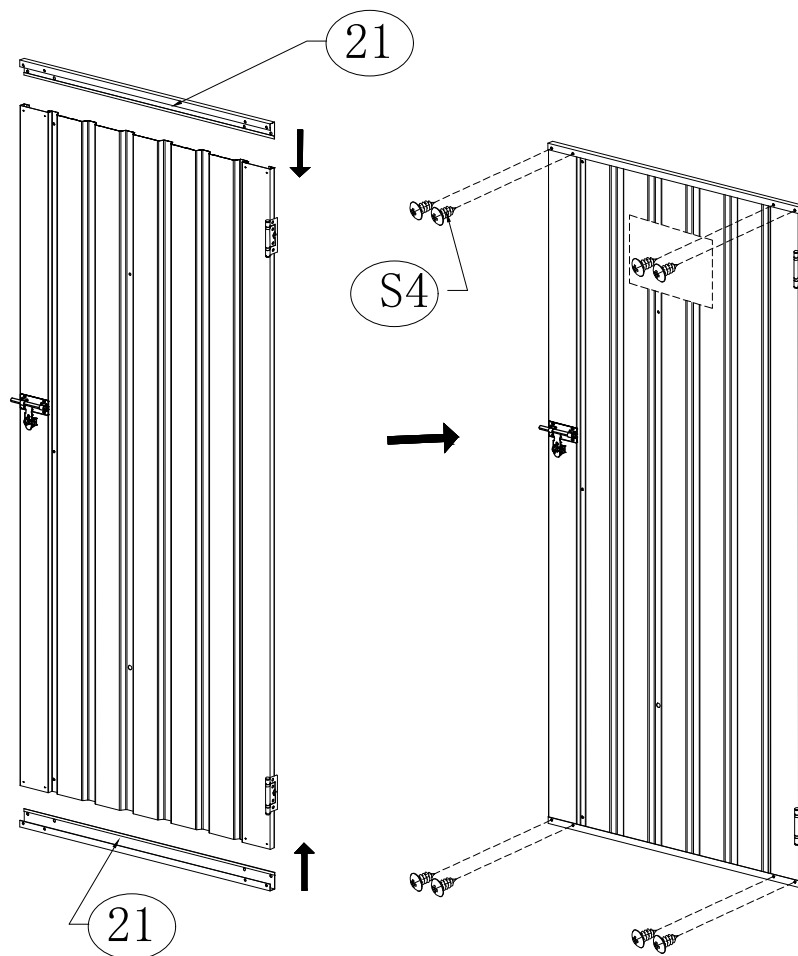

Put 16 on the side farther from the hole in the center of the tile and 23 on the side nearer.

NO.	PART.	Qty.
21	 705mm	2
S4		8

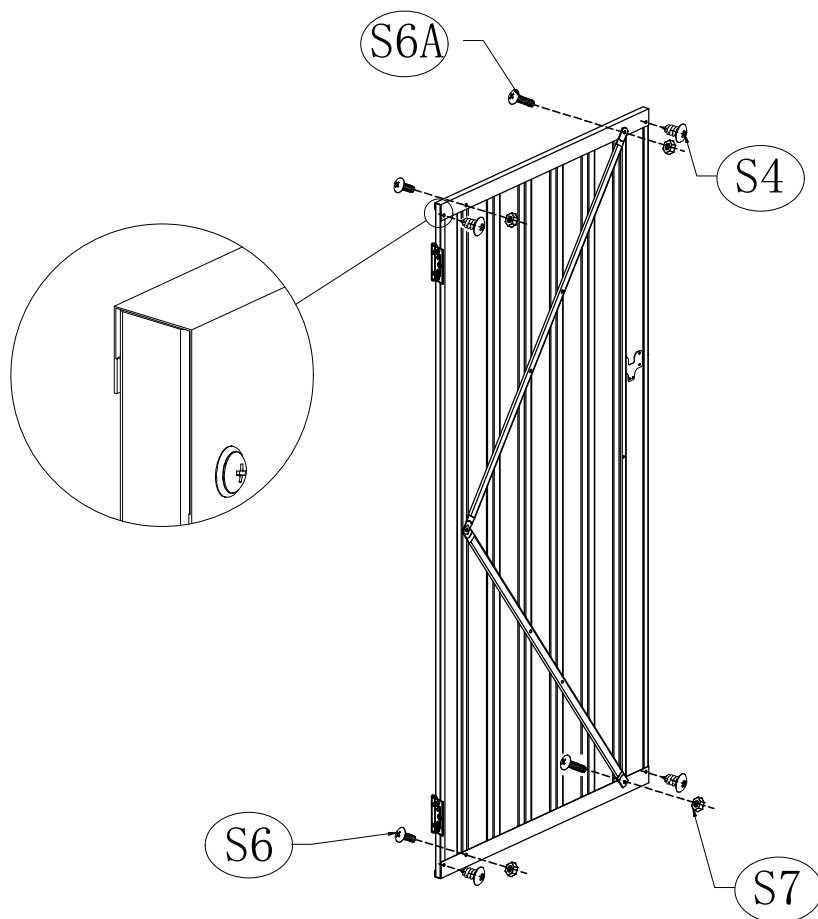

NO.	PART.	Qty.
S4		4
S6		2
S6A		2
S7		4



NO.	PART.	Qty.
S9		4
S34	 M6X50mm	7

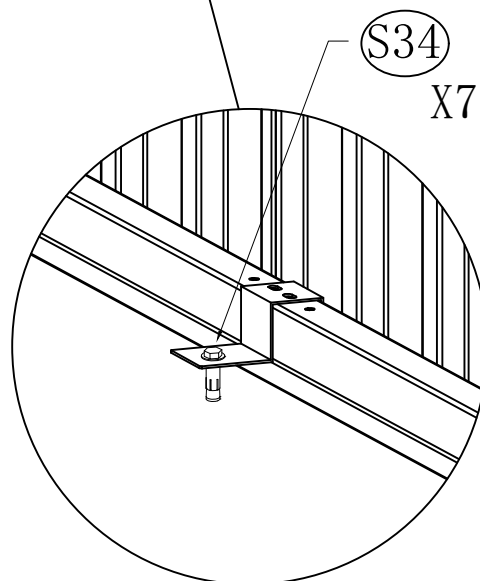
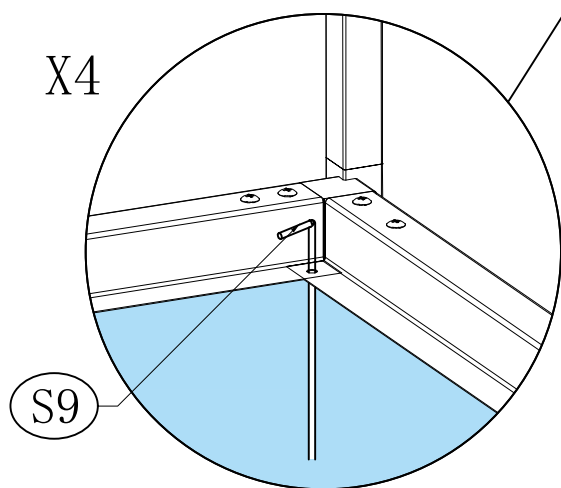
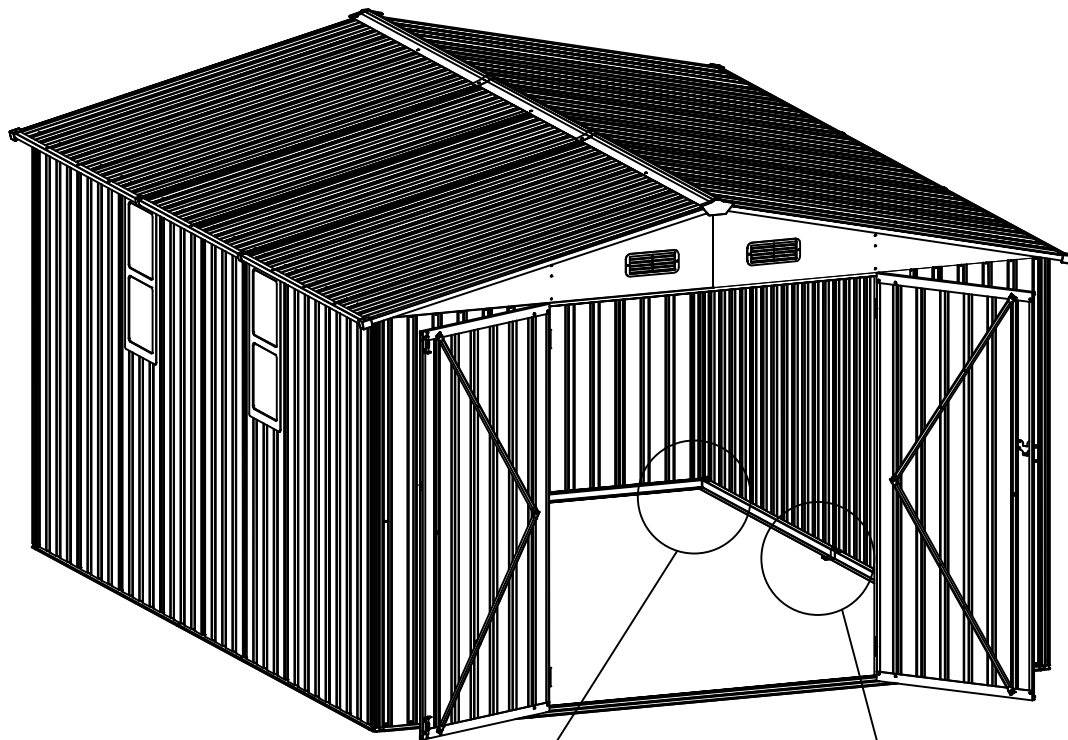

The screws of the M6X50 must be hit at the joint of the floor beam to make it stronger