











# Assembly Instructions

**Caution : You must read this before you proceed**

## Care & Maintenance



- ⊘  ● Not for commercial use. For residential use only.
- ⊘  ● Prolonged exposure to rain may cause rusting which can stain floors.
- ⊘  ● Do not put hot items directly on furniture surface.
- ⊘  ● Do not clean furniture with harsh cleansers or polish.
- ✓  ● To obtain the longest lifespan of your outdoor products, minimizing exposure to direct sunlight is recommended.
- ⊘  ● Children should not climb or jump on the furniture.
- ⊘  ● Do not write on furniture without a padded barrier to protect the surface.
- ✓  ● To obtain the longest lifespan of your outdoor products, avoid extended and lengthy exposure to rain, snow, and direct sunshine. Whenever possible cover the product and /or place under patio or awnings.
- ⊘  ● Stains may be removed with mild soap solution and damp cloth.
- ✓  ● Keep away from sources of ignition.
- ✓  ● Dust and pick-up spills using a clean, non-colored, lint-free cloth.

Please look in carton for hardware packs and legs.  
Sets often ship in multiple boxes and may arrive a day or two apart.

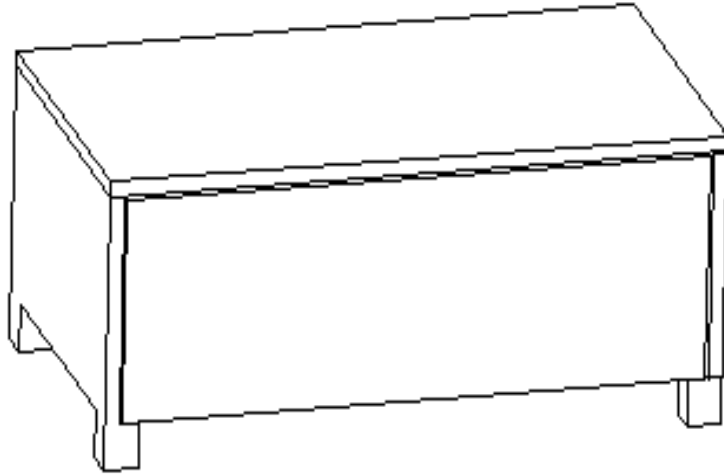

# Coffee Table

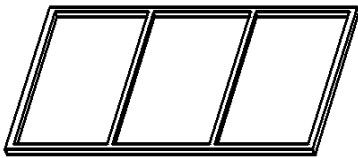

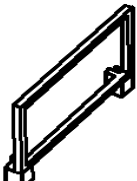
## Parts List

Label	Picture	Description	QTY
A		Top Panel	1
B		Front & Back Panel	2
C		Side Panel	2

# Hardware

Label	Picture	Description	QTY
①		Bolt (M6*40mm)	12
②		Washer	12
③		Allen Wrench	1

# Assembly Preparation

Before Beginning Assembly:

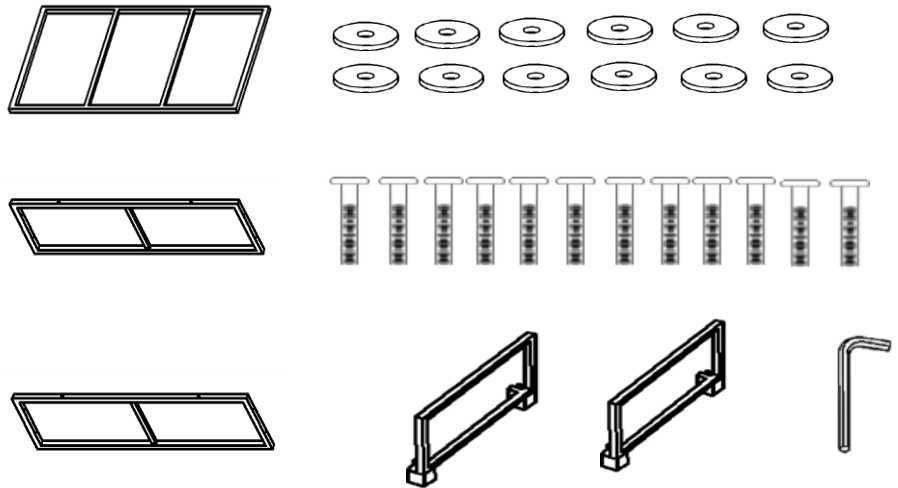

- Read instructions, cover to cover-



- Have 2 adults on hand for assembly-



- Do not assemble on flooring or carpet-



- Assemble on a clean non-marring surface (packing foam)-



- Save all packaging until finished-

# Assembly Steps

## Overview

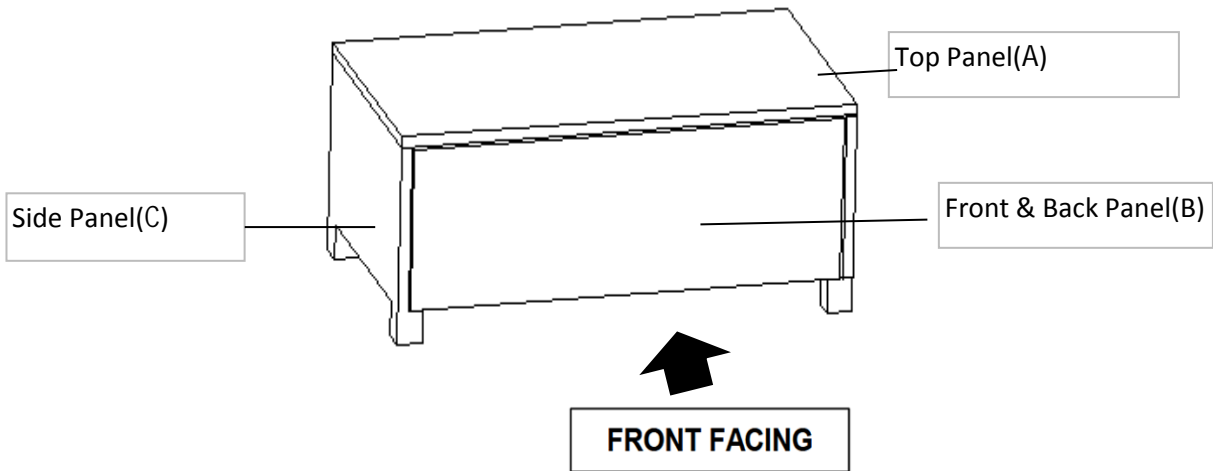

This Coffee Table has multiple parts and may require up to some 30 minutes to assemble. To give you an overview of Coffee Table parts, the above picture is to help you put the various parts into perspective. Please read through the instructions here below to familiarise yourself with the parts and steps before assembly.

# Assembly Steps

## Step 1

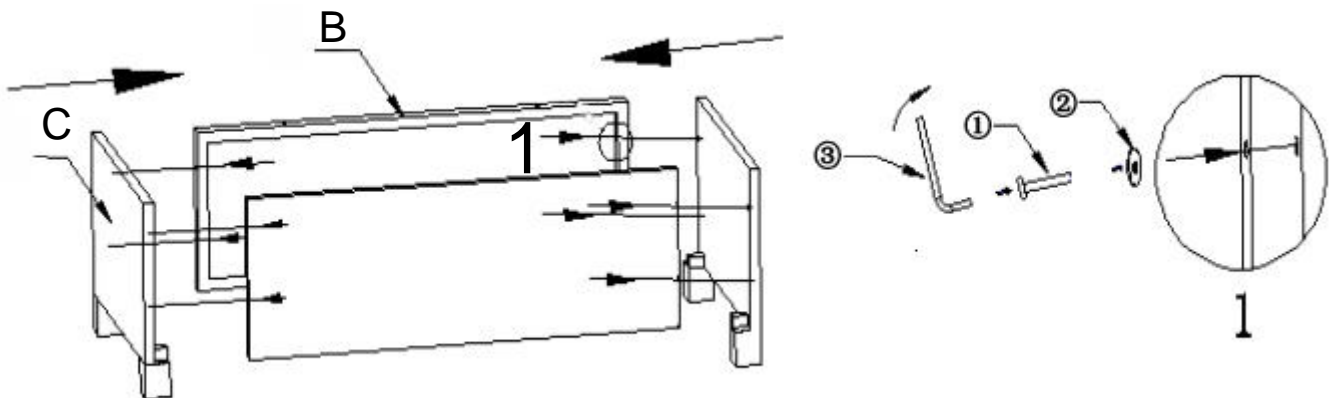

Open the carton and place all the parts onto a clean and soft surface, compare the real parts with the list above to make sure every parts is available.

Get total 4 panels in their upright positions, attach each Side Panel(C) to Front & Back Panle(B) with Washer(2) and Bolt(1) by using the Allen Wrench(3) to form a body base.

**Do not fully tighten the bolts at this stage.**

## Step 2

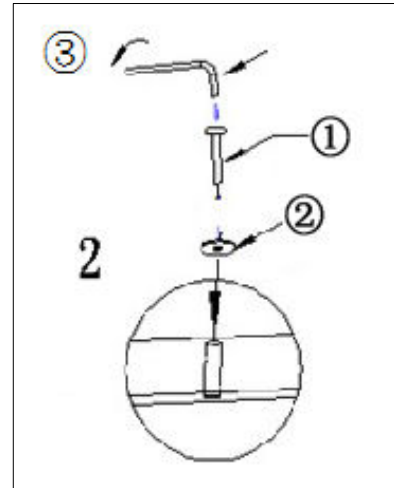
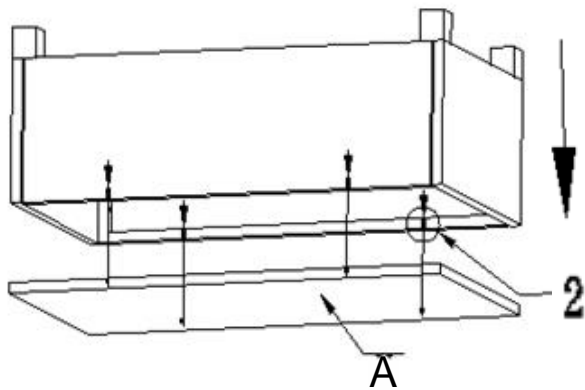

Put the Top Panel(A) with its face down onto a soft and clean surface, turn the body base upside down and place it onto the Top Panel(A).

Attach the Top Panel(A) with Washer(2) Bolt( ) by using the the Allen Wrench( 3) to make a whole body.

**Do not fully tighten the bolts.**

## Step 3

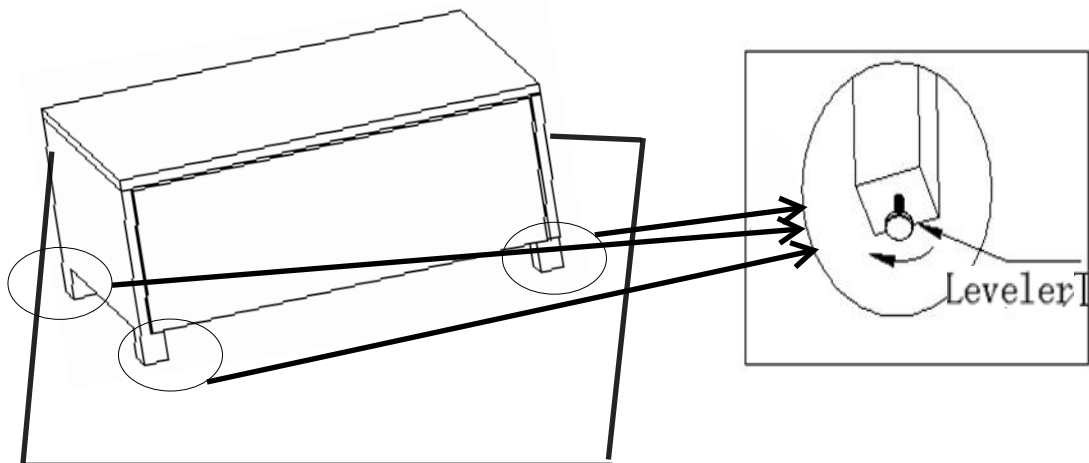

Adjust the Leveler to ensure good stability.

## Step 4

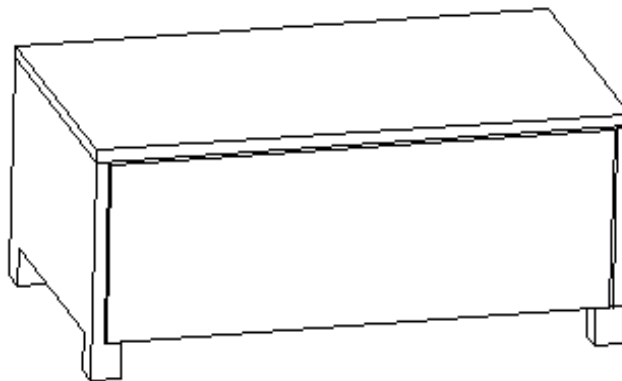

Your table is ready for use.

**This Table can only be used on a flat, level surface.**

# Loveseat

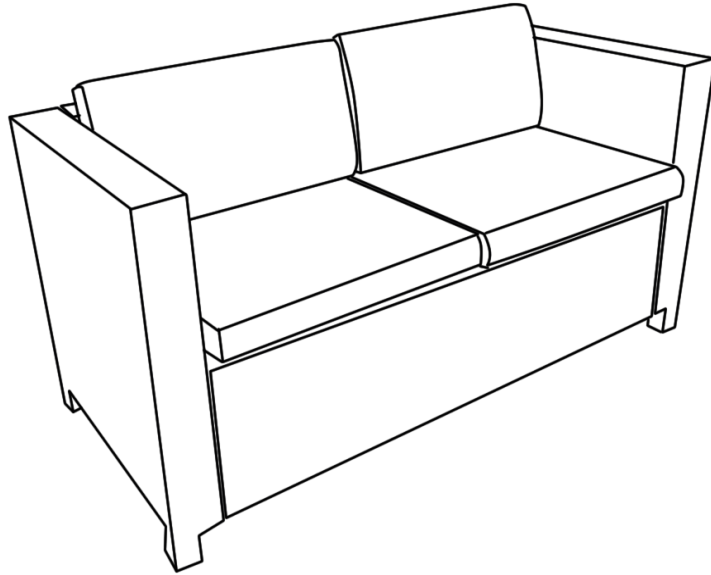

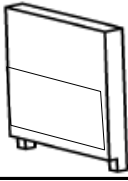
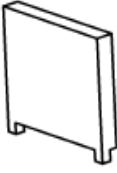
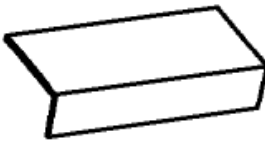

## Parts List

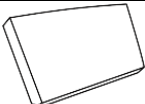
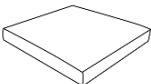
Label	Picture	Description	QTY
D		Loveseat - Backrest	1
E		Right Armrest	1
F		Left Armrest	1
G		Seat	1

H1		Back Cushion	2
H2		Seat Cushion	2

## Hardware

Label	Picture	Description	QTY
①		Bolt (M6*40mm)	14
②		Washer	14
③		Allen Wrench	1

## Assembly Preparation

Before Beginning Assembly:

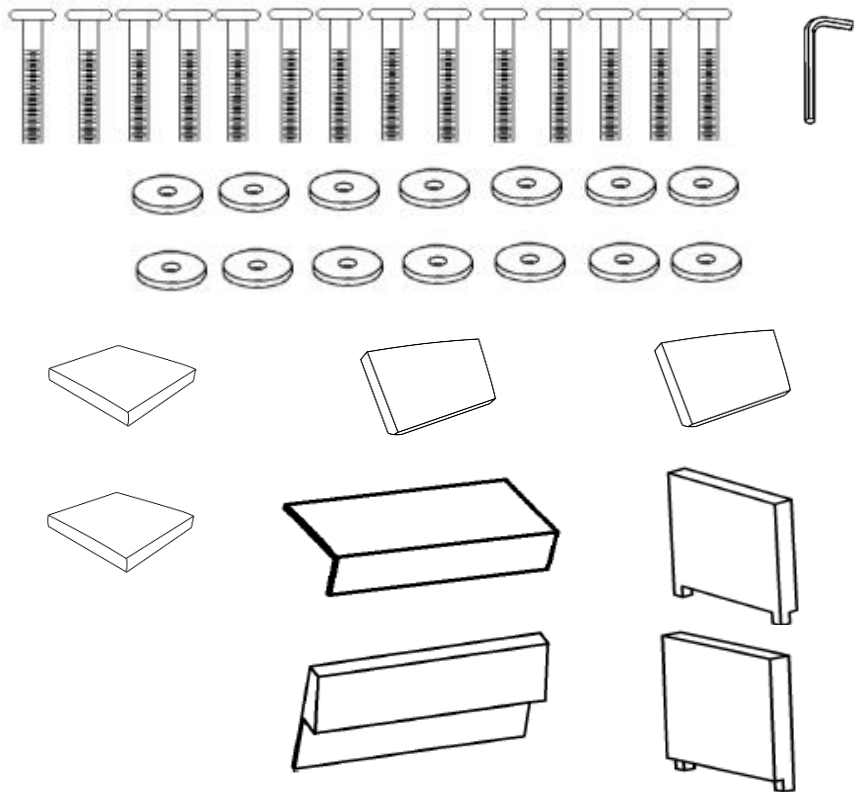

- Read instructions, cover to cover-



- Have 2 adults on hand for assembly-



- Do not assemble on flooring or carpet-



- Assemble on a clean non-marring surface (packing foam)-



- Save all packaging until finished-

# Assembly Steps

## Overview

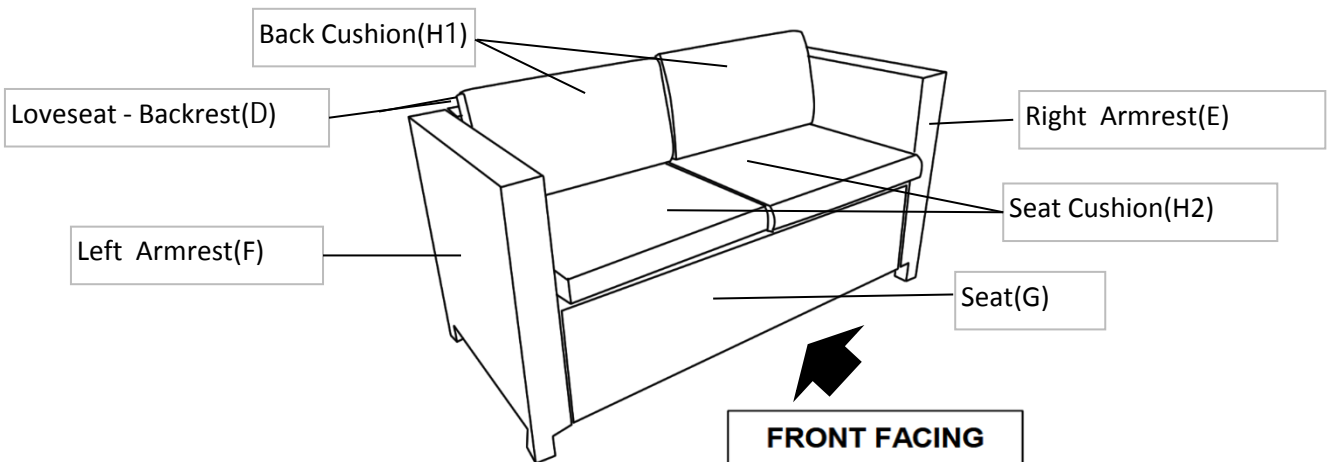

This Loveseat has multiple parts and may require up to some 30 minutes to assemble. To give you an overview of the Loveseat parts, the above picture is to help you put the various parts into perspective. Please read through the instructions here below to familiarise yourself with the parts and steps before assembly.

## Step 1

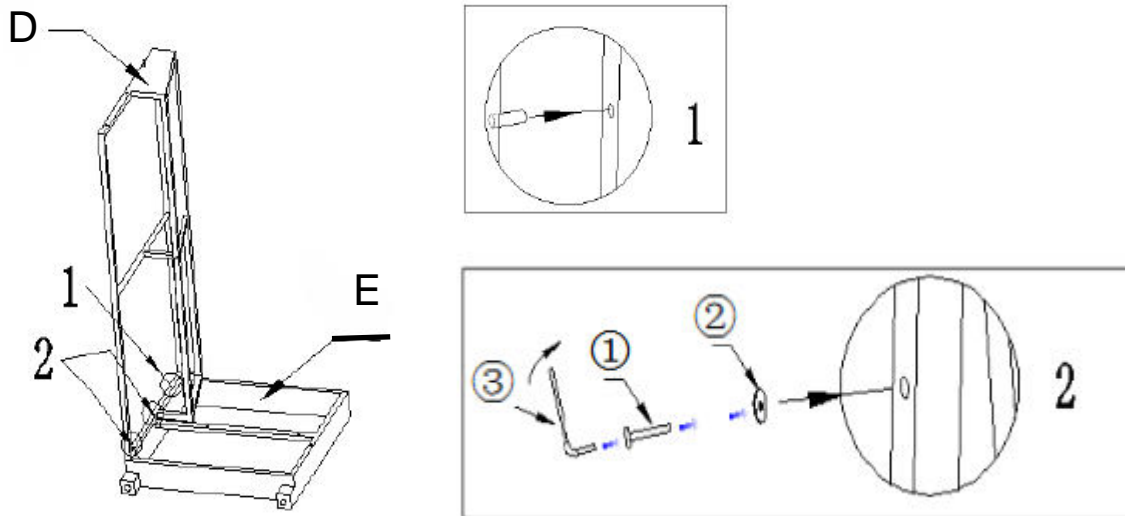

Open the carton and place all the parts onto a clean and soft surface.

Unpack all packages of hardware.

Place the Right Armrest(B) with its inner side, facing skywards .

Put the Backrest(D) against the Right Armrest(E), make the metal rod on the Backrest(A) insert into the MOUNTING POSITIONS of Right Armrest(E) as picture 1 shows.

Attach Backrest(G) and Right Armrest(B) together with hardware as picture 2 shows.

Use an Allen Wrench( ) to partially tighten these.

**Do not Fully Tighten at this stage.**

**There may be some PE wicker that may have covered the bolt points. To ease assembly, guide and slide the PE wicker away from the mounting positions. DO NOT CUT AWAY any PE WICKER as this would cause the wicker to unravel !**

## Step 2

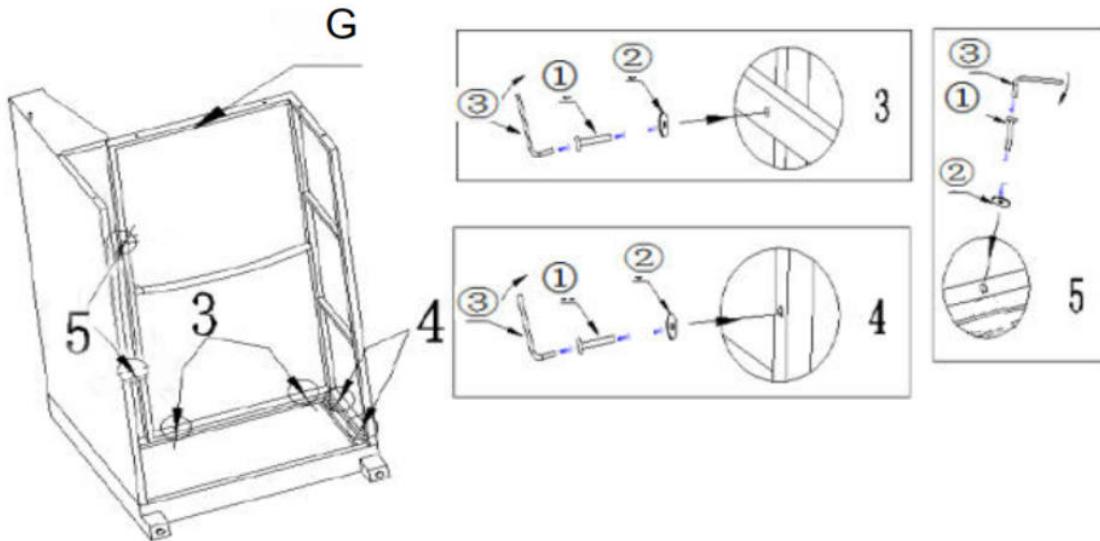

Place the Seat (G) between the Right Armrest(E) and Backrest(D).  
Attach the Seat(G) to the Right Armrest(E) with hardware as picture 3 and 4 shows.  
Attach Seat(G) to the Backrest(D) with hardware as picture 5 shows.  
Use an Allen Wrench(③) to partially tighten these.  
**Do not Fully Tighten at this stage.**

## Step 3

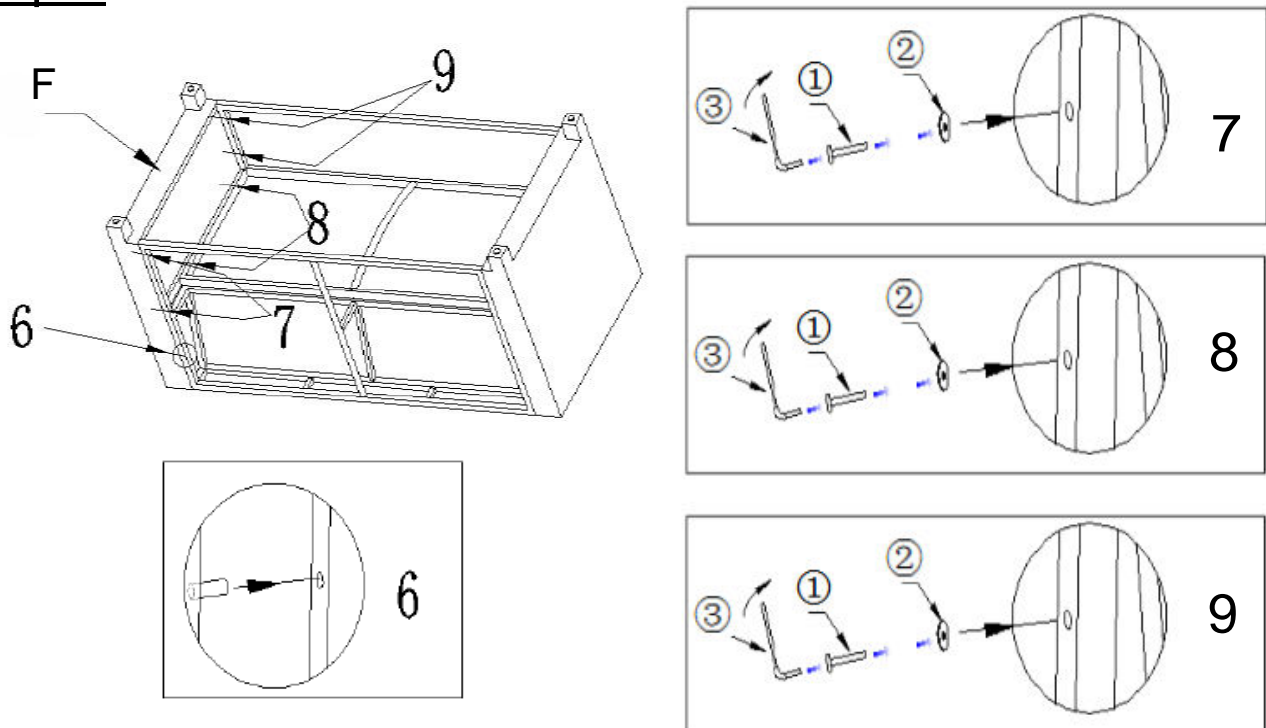

Place the Left Armrest ( F ) against the Backrest(D) and the Seat(G).  
Make the metal rod on Backrest(D) insert into the MOUNTING POSITION of Left Armrest( F ) as picture 6 shows.  
Attach the Backrest ( D ) to the Left Armrest( F ) with hardware as picture 7 shows.  
Attach the Seat(G) to the Left Armrest(F ) with hardware as picture 8 and 9 shows.  
Use an Allen Wrench(③) to partially tighten these.  
**Do not Fully Tighten at this stage.**

## Step 4

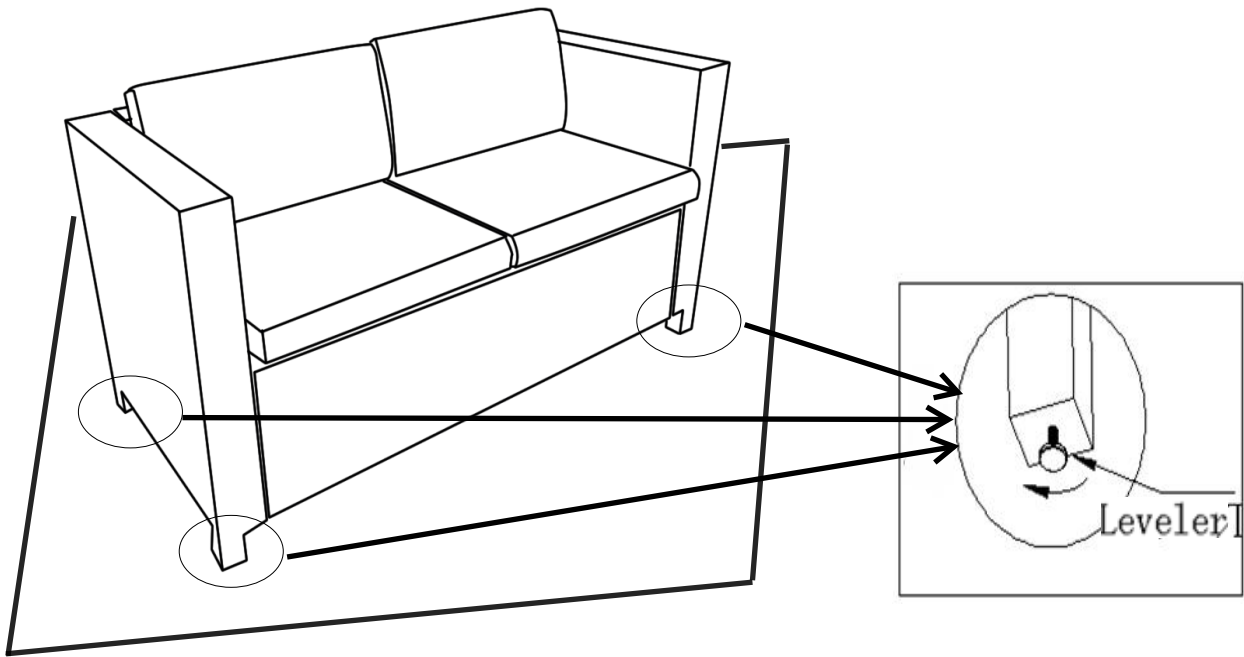

Adjust the Leveler to ensure good stability.

## Step 5

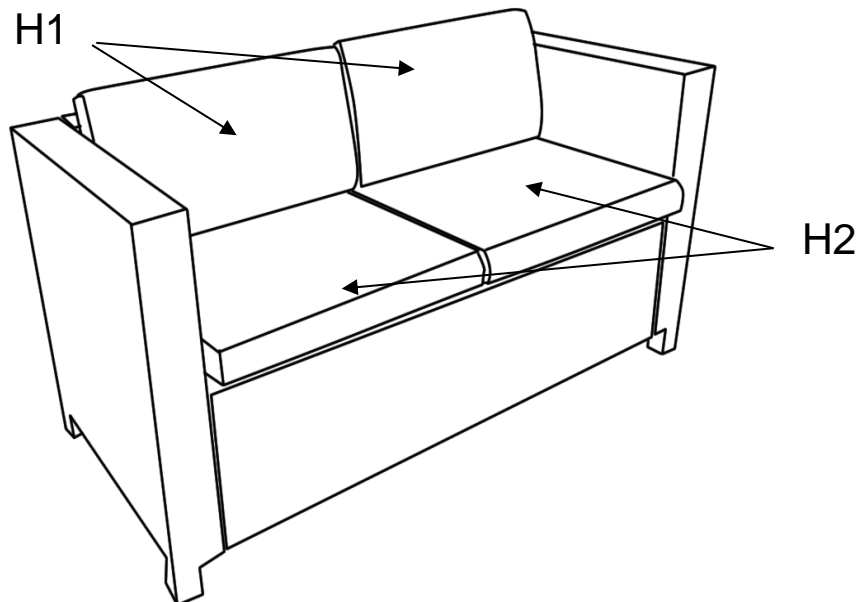



Put the Seat Cushion(H2) & Back Cushion(H1) on the Loveseat.  
Your Loveseat is ready for use.

**This Loveseat can only be used on a flat, level surface.**

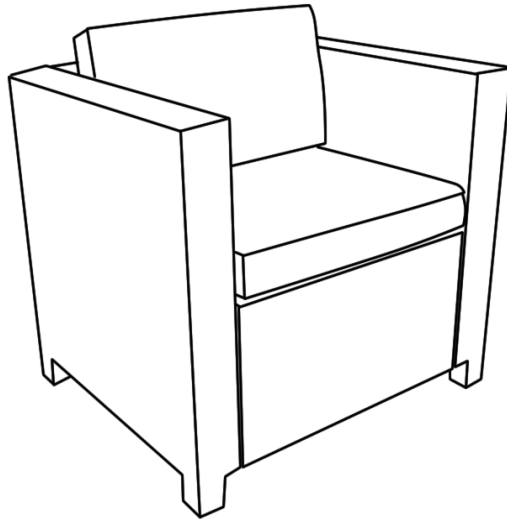
# Chair



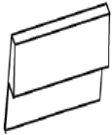
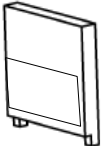
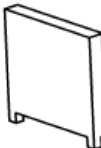
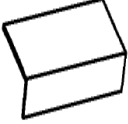

## Parts List

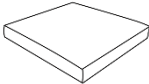
Label	Picture	Description	QTY
I		Chair - Backrest	1
E		Right Armrest	1
F		Left Armrest	1
L		Seat	1
M1		Back Cushion	1

M2		Seat Cushion	1
----	---	--------------	---

## Hardware

Label	Picture		QTY
①		Bolt M6*40mm	13
②		Washer	13
③		Allen Wrench	1

## Assembly Preparation

Before Beginning Assembly:

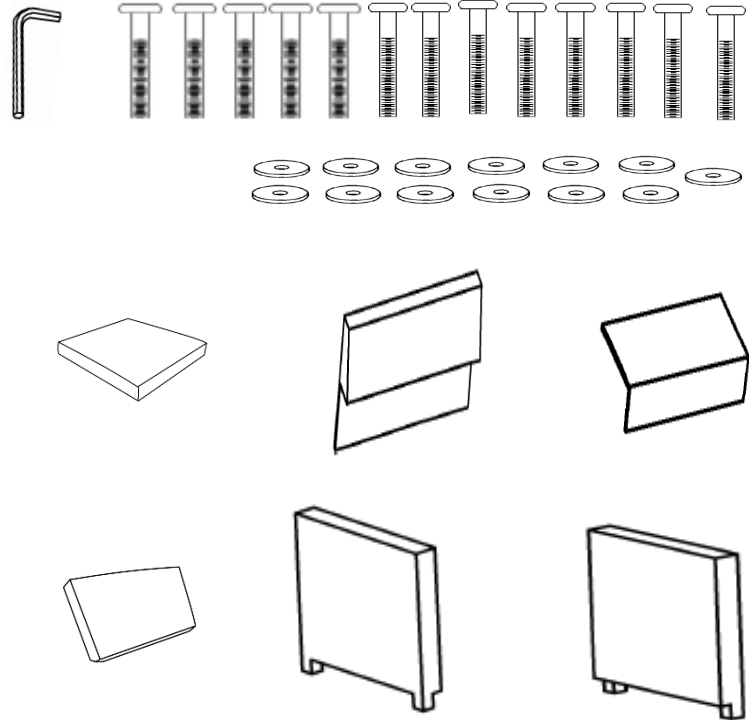

- Read instructions, cover to cover-



- Have 2 adults on hand for assembly-



- Do not assemble on flooring or carpet-



- Assemble on a clean non-marring surface (packing foam)-



- Save all packaging until finished-

# Assembly Steps

## Overview

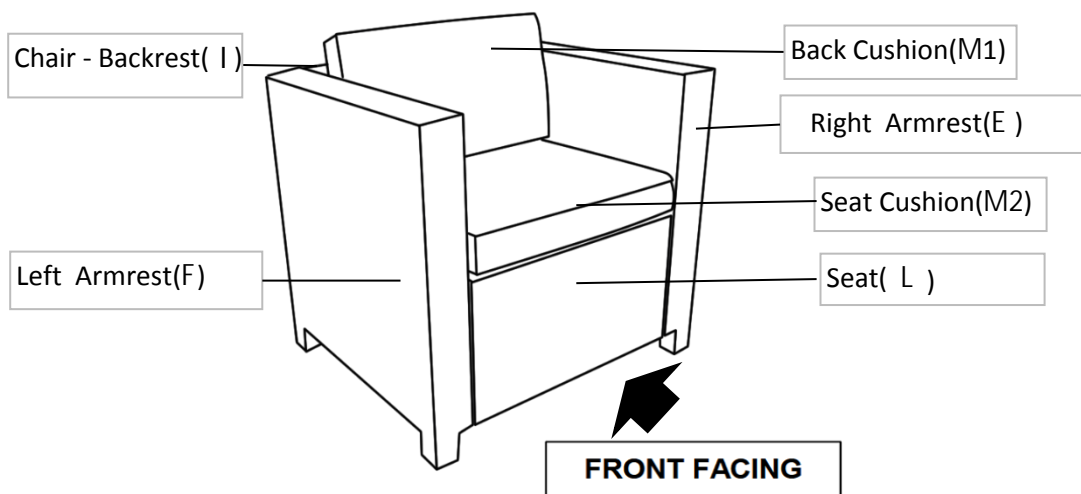

This Chair has multiple parts and may require up to some 30 minutes to assemble. To give you an overview of the Chair parts, the above picture is to help you put the various parts into perspective. Please read through the instructions herebelow to familiarise yourself with the parts and steps before assembly.

## Step 1

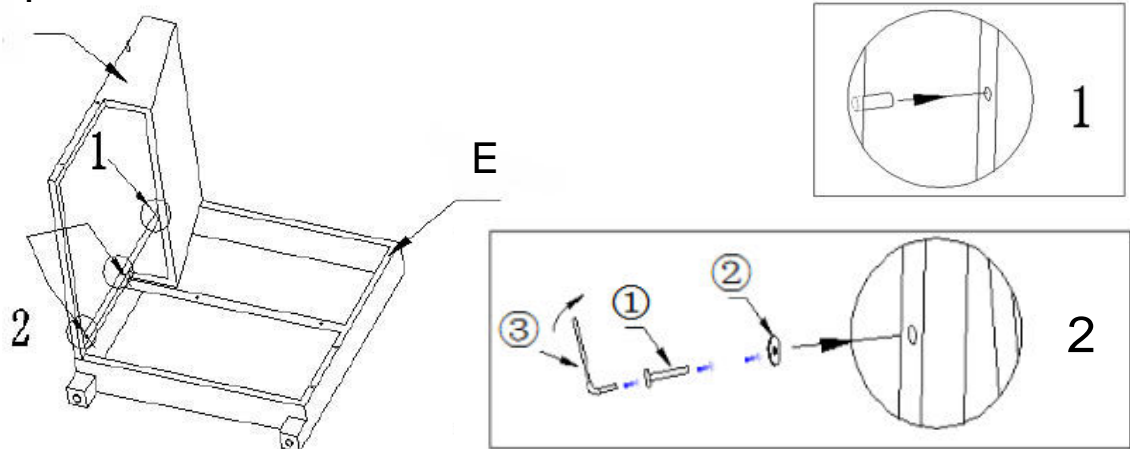

Open the carton and place all the parts onto a clean and soft surface.

Unpack all packages of hardware.

Place the Right Armrest (E) with its inside facing skywards.

Put the Backrest(I) against the Right Armrest(E), make the metal rod on the Backrest(I) insert into the MOUNTING POSITION of the Right Armrest(E) as picture 1 shows.

Then attach Backrest(I) and Right Armrest(E) together with hardware as picture 2 shows.

Use an Allen Wrench( ) to partially tighten these.

**Do not fully tighten the bolts.**

**It can happen that some of the PE wicker covers the bolt points, preventing easy assembly the PE wicker should not be cut but only moved away from the mounting positions.**

## Step 2

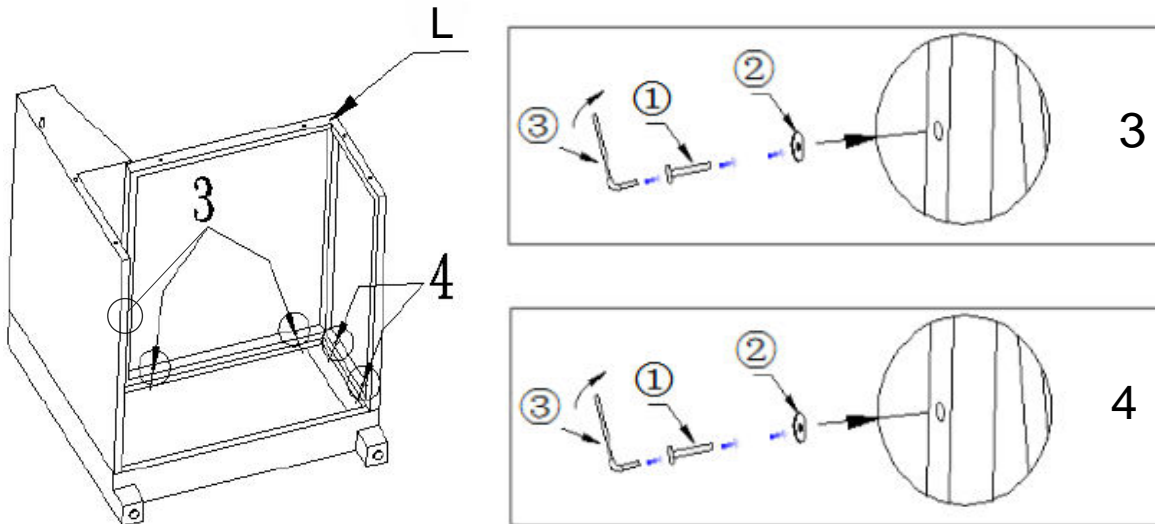

Place the Seat (L) between the Right Armrest(E) and Backrest(I).  
Attach the Seat(L) to the Right Armrest(E) with hardware as picture 3 and 4 shows.  
Use an Allen Wrench( ) to partially tighten these.  
**Do not fully tighten the bolts.**

## Step 3

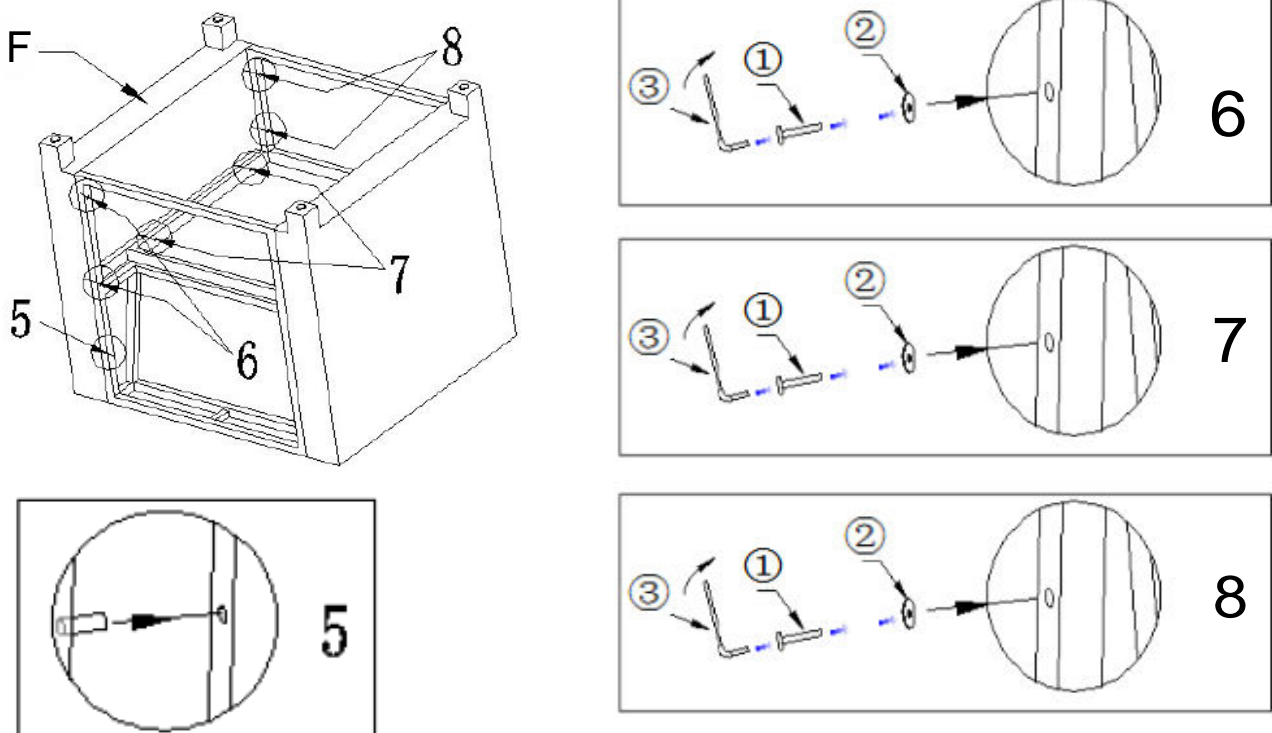

Place the Left Armrest ( F ) against the Backrest(I) and Seat(L).  
Make the metal rod on the Backrest(I) insert into the MOUNTING POSITION of the Left Armrest(F ) as picture 5 shows.  
Attach the Left Armrest(F ) to Backrest(I) with hardware as picture 6 shows.  
Attach the Left Armrest(F ) to Seat(L) with hardware as picture 7 and 8 shows.  
Use an Allen Key(③) to partially tighten these.  
**Do not fully tighten the bolts.**

## Step 4

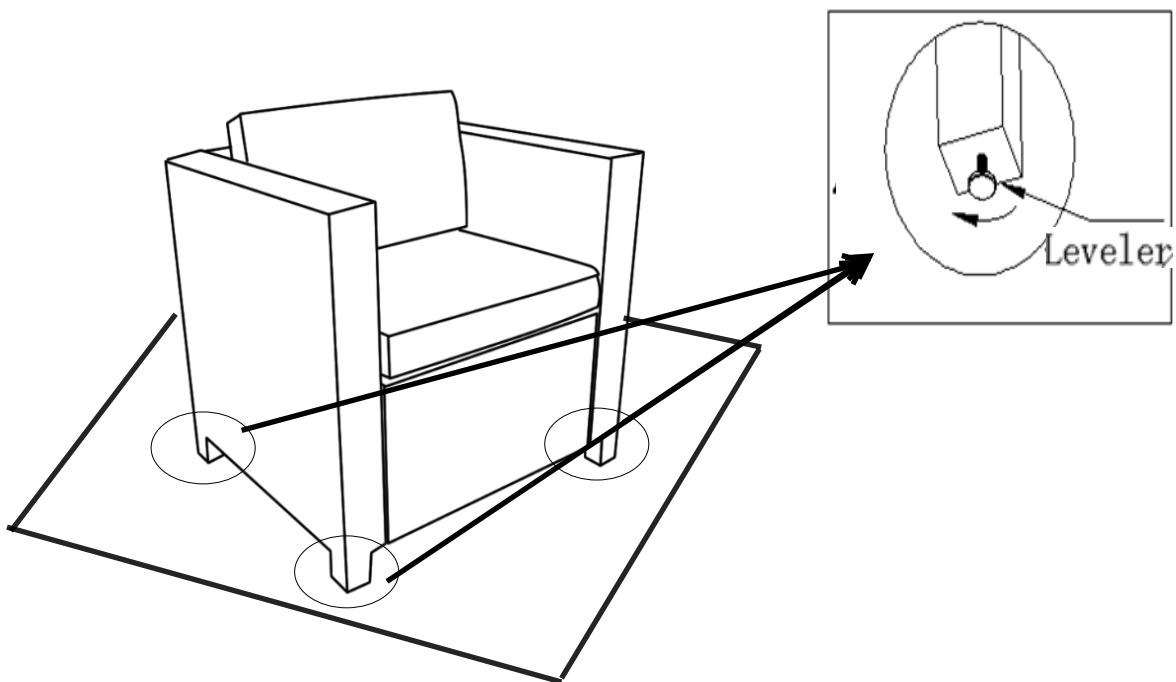

Tighten all bolts completely. adjust the Leveler to ensure good stability.

## Step 5

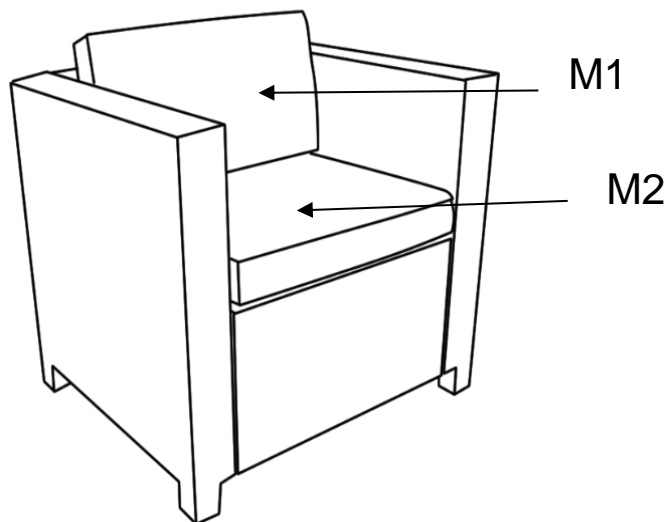

Put the Seat Cushion(M1) & Back Cushion(M2) on the Chair  
It is ready for use.

**This Chair can only be used on a flat, level surface.**