

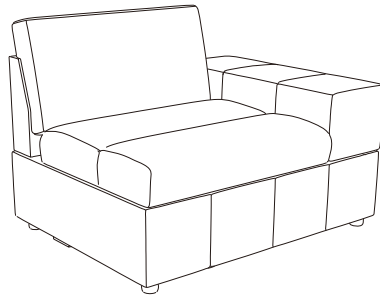

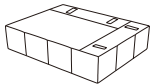

# ASSEMBLY INSTRUCTION

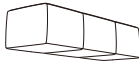

## PARTS LIST

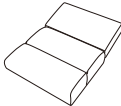
								
<b>A</b>	x1	<b>B</b>	x1	<b>C</b>	x1	<b>D</b>	x1	

## HARDWARE LIST

				
<b>1</b>	x4	<b>2</b>	x4	

## SOFA ASSEMBLY INSTRUCTION

Step1

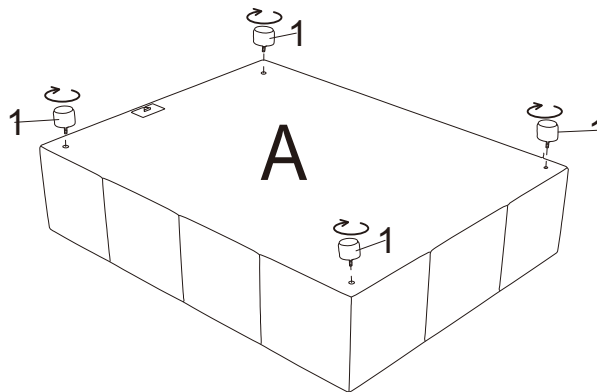

Step2

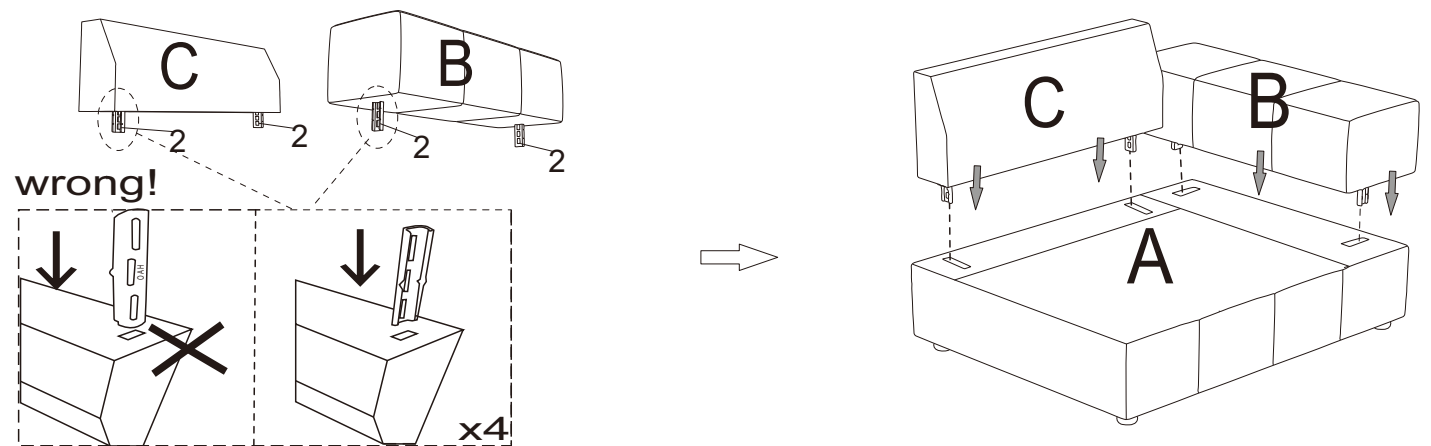

### Step3

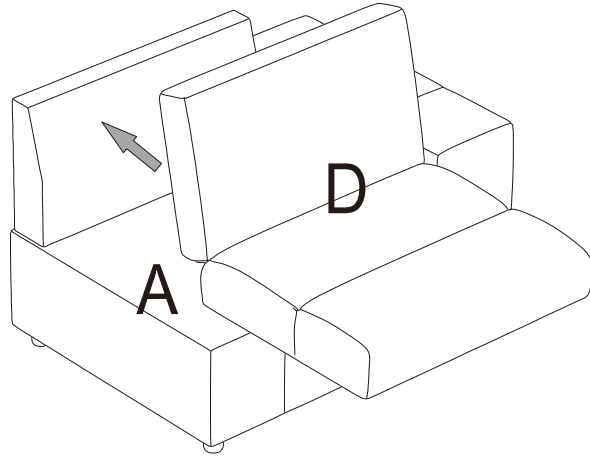

### Step4

1. Located on the bottom of each pieces are wedges and clamps.

Rotate the clamps 180° so the teeth are facing outward.

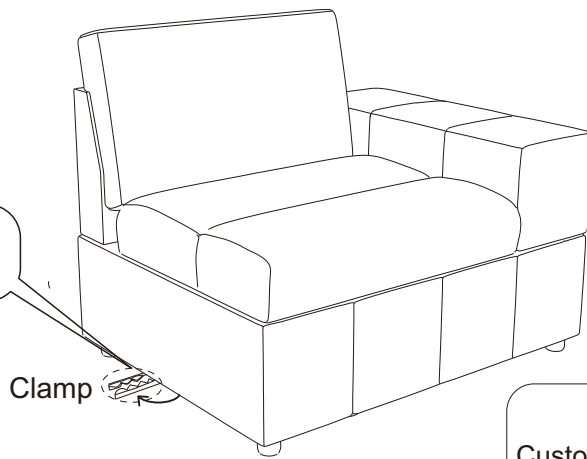

2. Slide the pieces together until the wedge engages the teeth clamp and the two pieces are snug.

Custom Modulus Sectional  
Connect different pieces into  
the desired configuration

