







ASSEMBLY INSTRUCTIONS

COFFEE TABLE

Thank you for purchasing this quality product. Be sure to check all packing material carefully for small parts that may have come loose inside the carton during shipment.

Key		
	Q'Ty	Description
1	1 pc	Table Top
2	2 pcs	Side Leg Assembly
3	2 pcs	Front Facing Stretchers
4	4 pcs	Caster

Hardware kit			
No		Description	Q'Ty
A		Bolt Ø7.8 x 80mm	4 pcs
B		Lock Washer Ø8.5	8 pcs
C		Flat Washer Ø8.5	4 pcs
D		Allen Key	1 pc
E		Dowel Ø10 x 40mm	4 pcs
F		Bolt Ø7.8 x 50mm	4 pcs
G		Curved Washer	4 pcs

- Carefully lay the Table Top upside down on a smooth flat surface to prevent scratches.
 - Insert dowel (E) to Front facing side stretchers (Detail A)
 - Attach Side Leg Assembly and Front Facing Stretchers to the Table Top
 - Insert a Bolt (A) with Flat washer (C), and Lock washer (B) through holes in wood corner of Table Top. Do not fully tighten. (Detail C)
 - Insert a Bolt (F) with a Curved washer (G), and a Lock washer (B) through holes. (Detail B)
- Securely tighten all bolts once all pieces are in place.

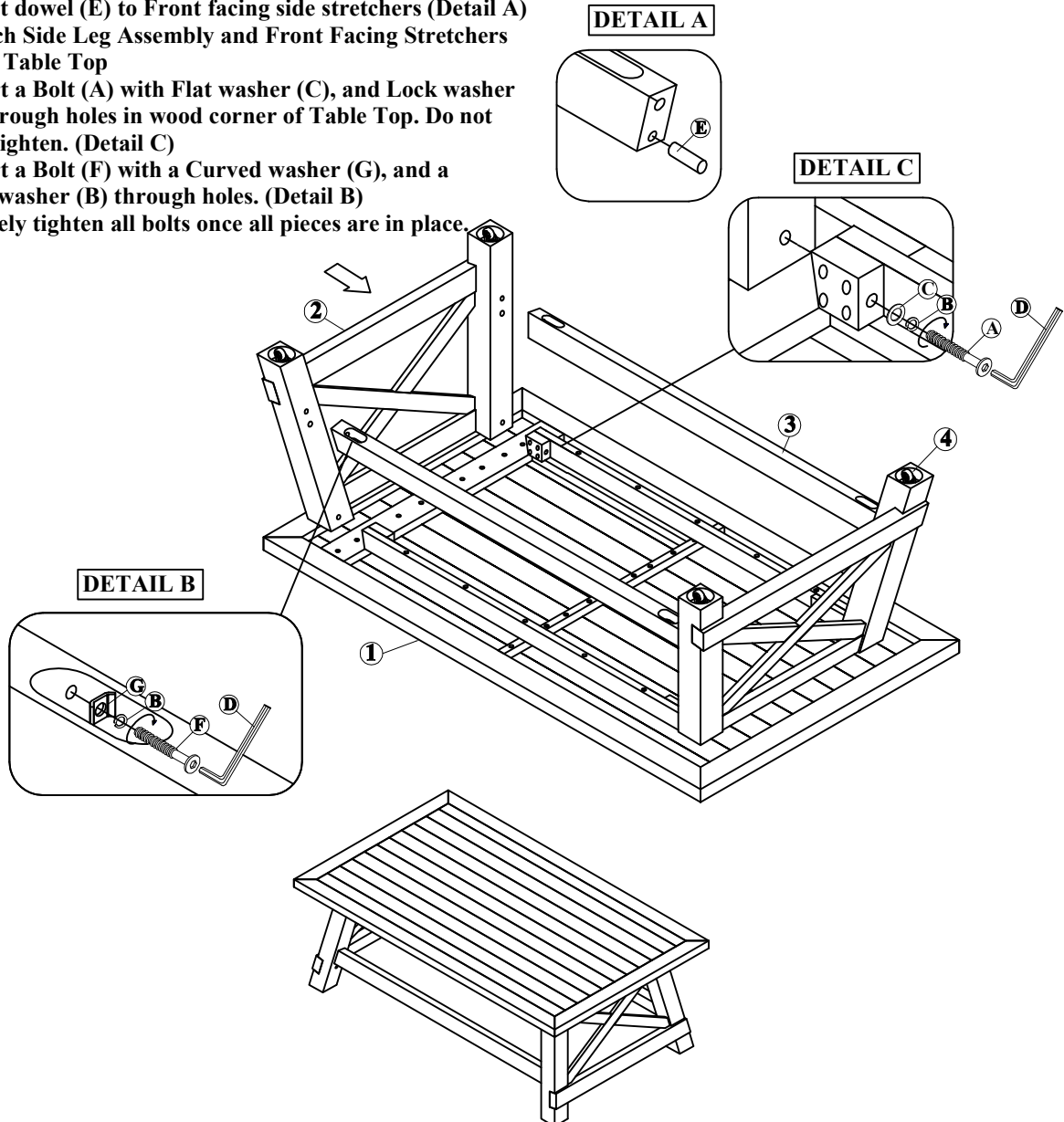

MADE IN VIETNAM