

ASSEMBLY INSTRUCTIONS



WRITING DESK

ASSEMBLY INSTRUCTIONS

ASSEMBLY TIPS:

1. Remove hardware from box and sort by size.
2. Please check to see that all hardware and parts are present prior to start of assembly.
3. Please follow attached instructions in the same sequence as numbered to assure fast & easy assembly.



WARNING!

1. Don't attempt to repair or modify parts that are broken or defective. Please contact the store immediately.
2. This product is for home use only and not intended for commercial establishments.

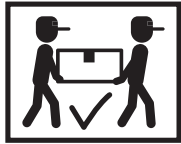

ASSEMBLY TIME

60 MINUTES

PARTS IDENTIFICATION

A	LEFT SIDE PANEL		1 PC	J	DRAWER FRONT PANEL		2 PCS
B	RIGHT SIDE PANEL		1 PC	K	DRAWER BACK PANEL		2 PCS
C	LEFT DIVIDER PANEL		1 PC	L	DRAWER LEFT SIDE PANEL		2 PCS
D	RIGHT DIVIDER PANEL		1 PC	M	DRAWER RIGHT SIDE PANEL		2 PCS
E	LEFT BOTTOM PANEL		1 PC	N	DRAWER BOTTOM PANEL		2 PCS
F	MIDDLE BOTTOM PANEL		1 PC	O	MIDDLE DRAWER FRONT PANEL		1 PC
G	RIGHT BOTTOM PANEL		1 PC	P	MIDDLE DRAWER BACK PANEL		1 PC
H	BACK PANEL		1 PC	Q	MIDDLE DRAWER LEFT SIDE PANEL		1 PC
I	TOP PANEL		1 PC	R	MIDDLE DRAWER RIGHT SIDE PANEL		1 PC

NOTE:

Phillips head screw driver is required in the assembly process; however, manufacturer does not provide this item.

S MIDDLE
DRAWER
BOTTOM PANEL

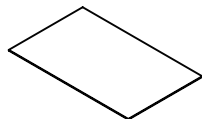

1 PC

U CROSS BAR

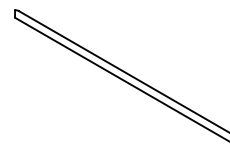

1 PC



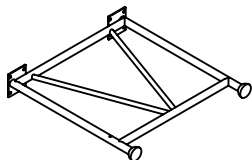







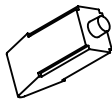

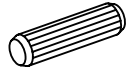
T METAL FRAME

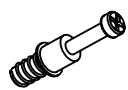

2 PCS

Z

HARDWARE IDENTIFICATION

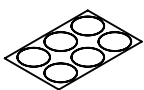
NO	DESCRIPTION	FIGURE	Q'TY	NO	DESCRIPTION	FIGURE	Q'TY
1	GLUE 40g		1 PC	8	GLIDES SCREW Ø 3x12mm SR		36 PCS
2	WOODEN DOWEL Ø 8x30mm		45 PCS	9	KNOB		3 PCS
3	CAM BOLT Ø 7x35.5mm SR		20 PCS	10	KNOB BOLT Ø 4x28mm BLK		3 PCS
4	CAM LOCK Ø 15x12mm SR		20 PCS	11	BOLT M 6x20mm BLK		16 PCS
5	LONG SCREW Ø 4.5x42mm SR		16 PCS	12	LONG BOLT M 6x44mm BLK		2 PCS
6	SCREW Ø 4.3x35mm SR		12 PCS	13	ALLEN WRENCH 4mm SR		1 PC
7	GLIDES L = 350mm WHT		3SET	14	STICKER Ø 20mm		4 PCS

Z7,Z9,Z10 not included in blister packaging.

NOTE:

Phillips head screw driver is required in the assembly process; however, manufacturer does not provide this item.

STEP 1

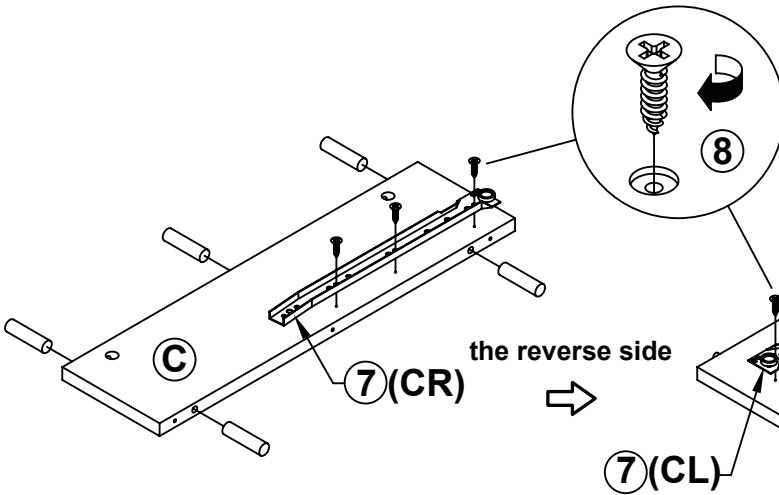
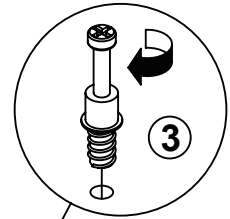
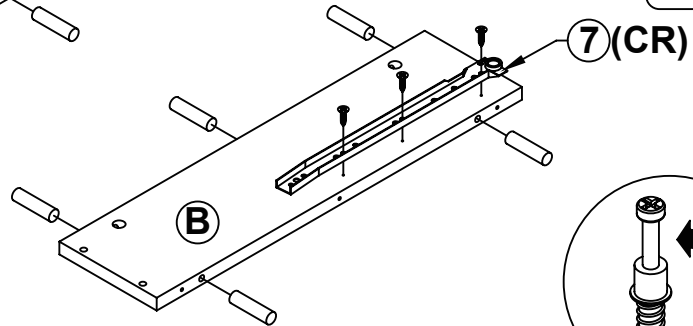
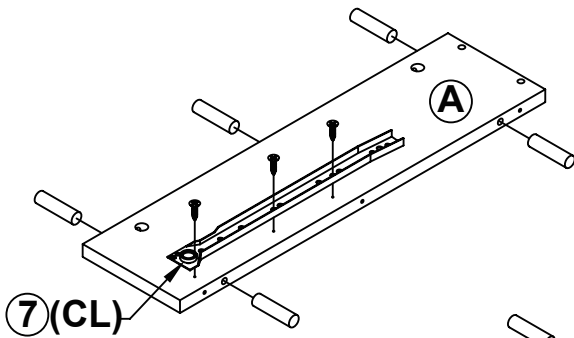
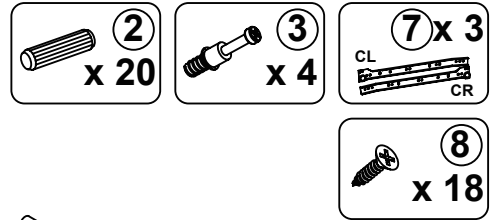

the reverse side

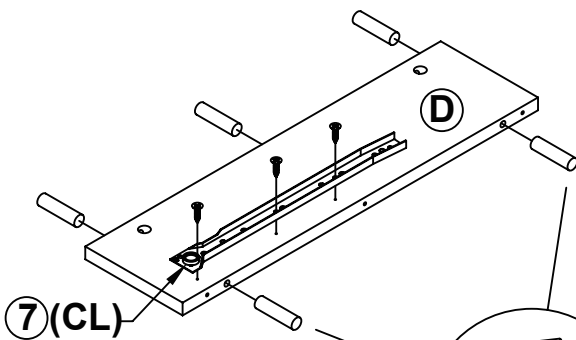
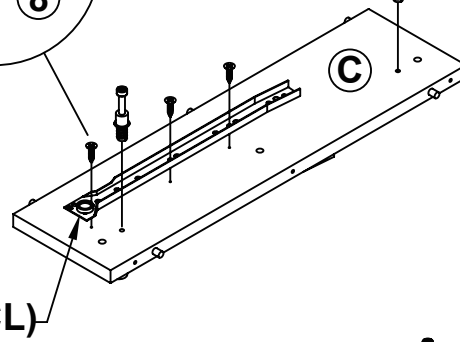

the reverse side

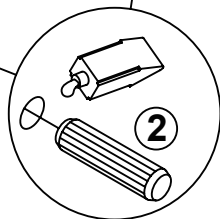
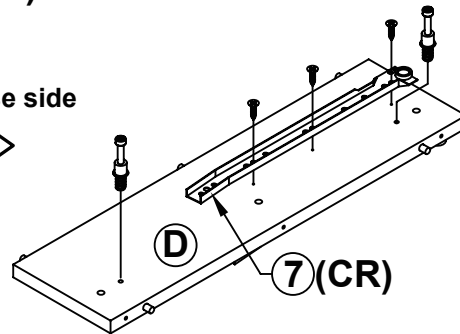

INCORRECT
CORRECT

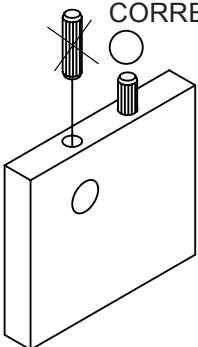

Apply glue on all wooden dowels to ensure integrity of the structure.

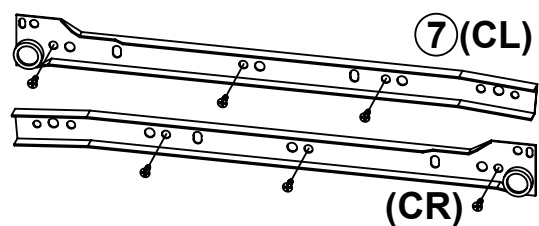

STEP 2

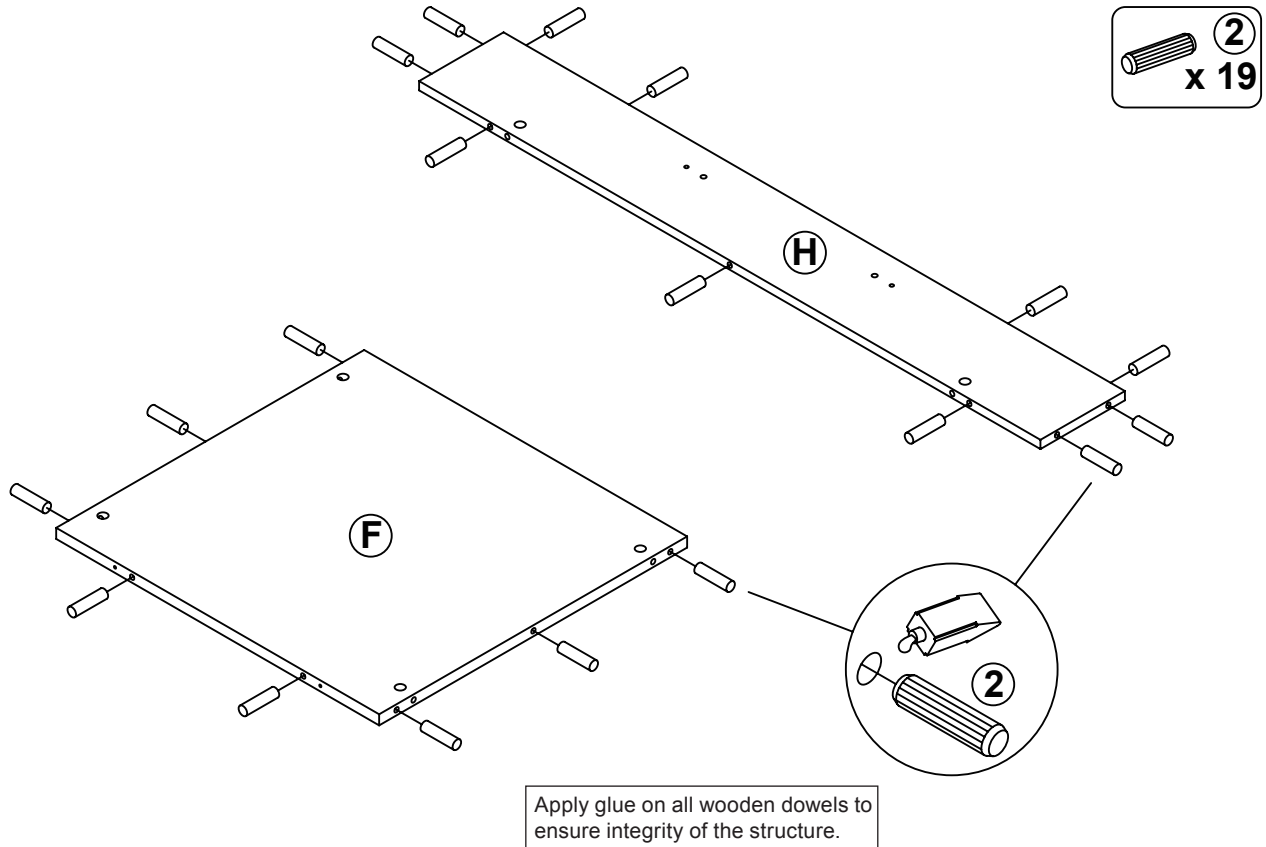

STEP 3

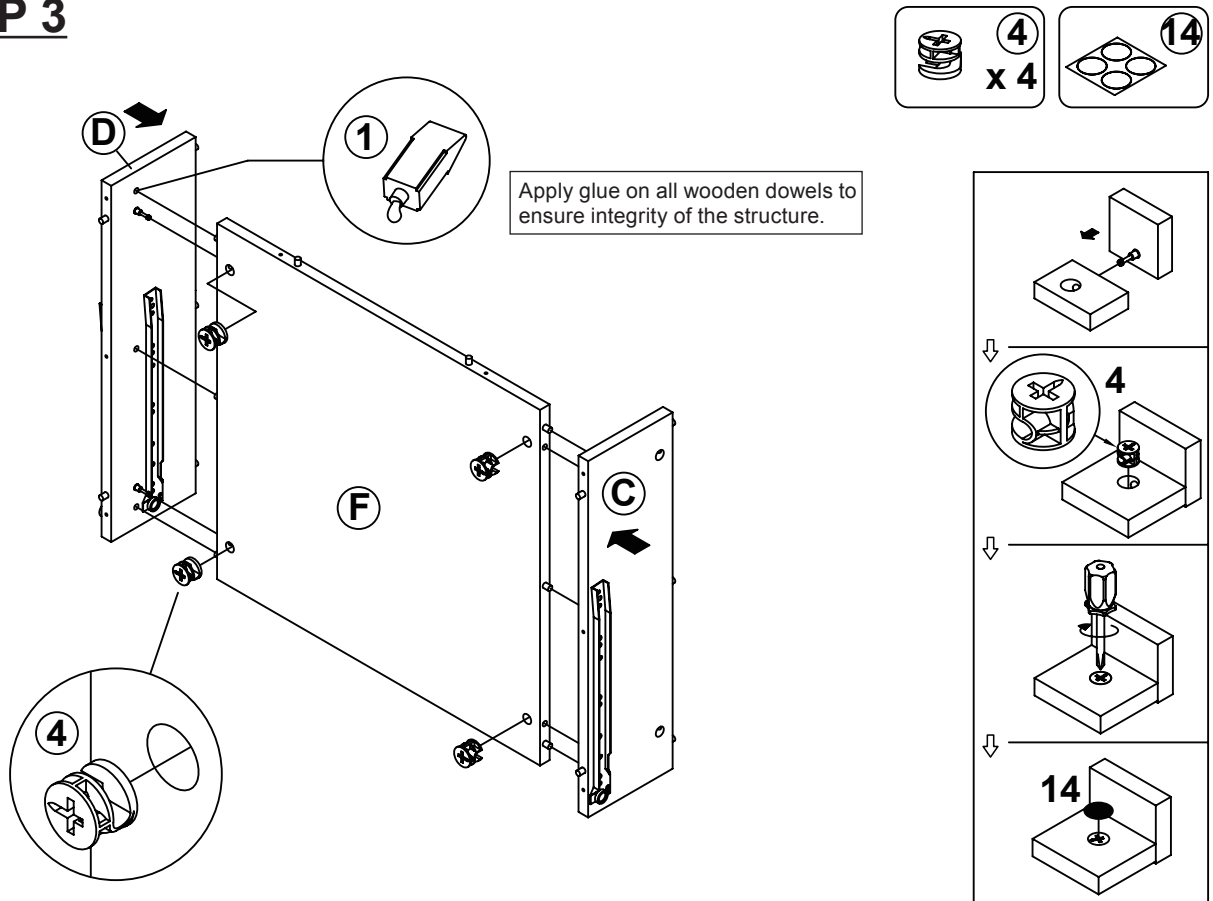

STEP 4

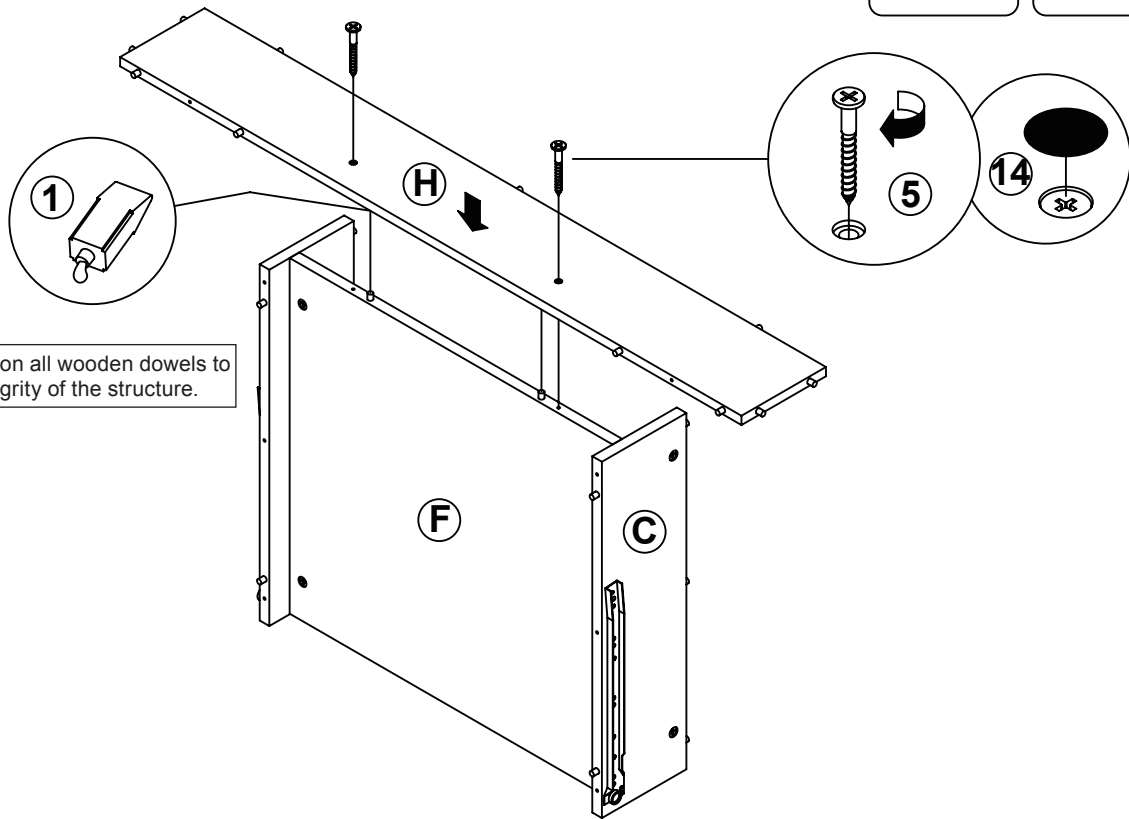
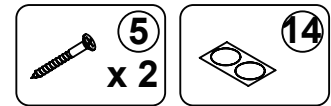

Apply glue on all wooden dowels to ensure integrity of the structure.

STEP 5

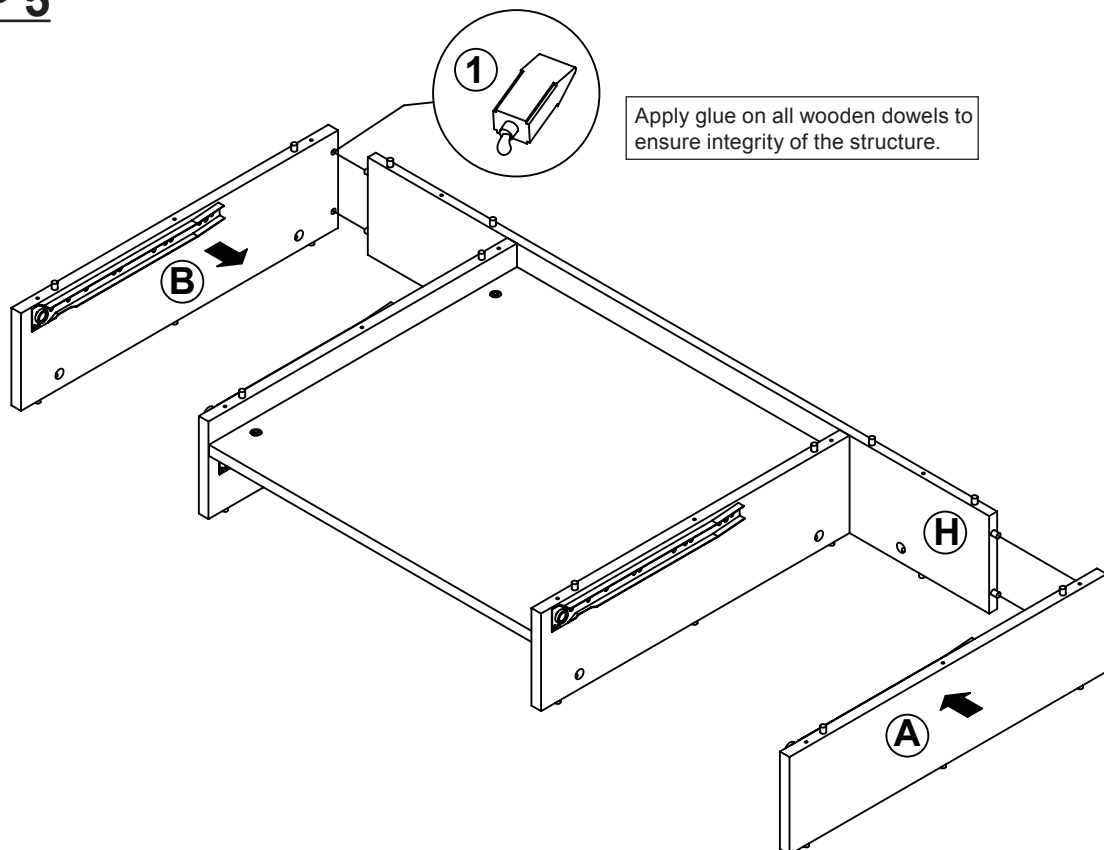

Apply glue on all wooden dowels to ensure integrity of the structure.

STEP 8

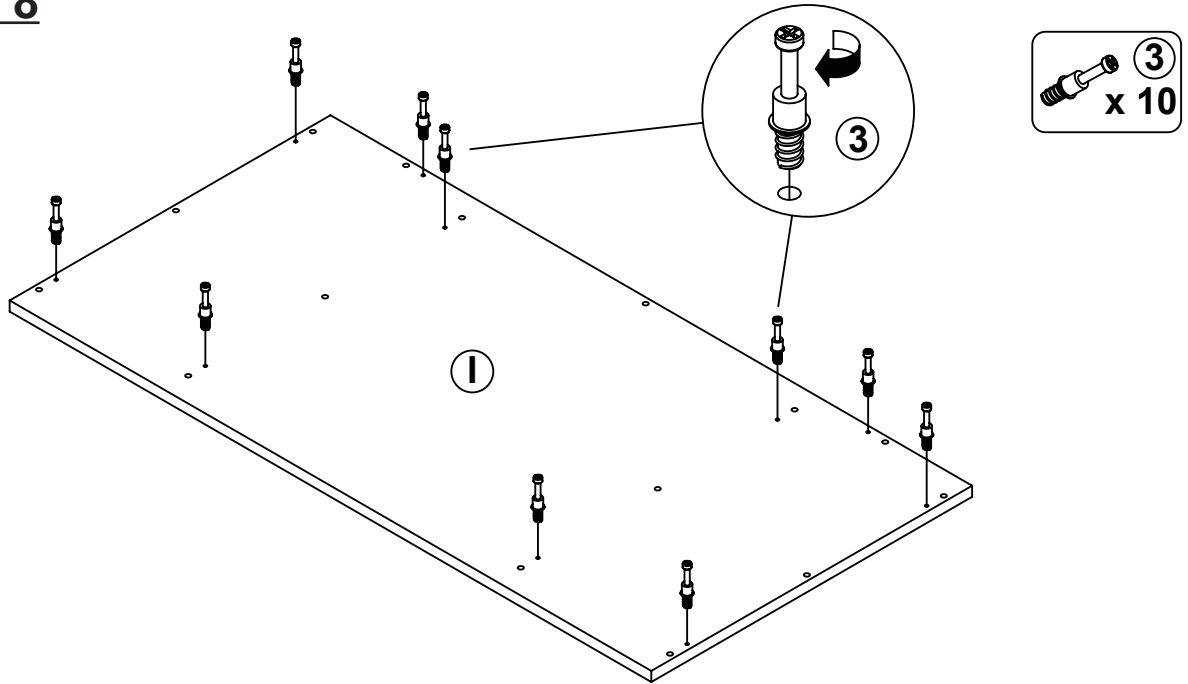

STEP 9

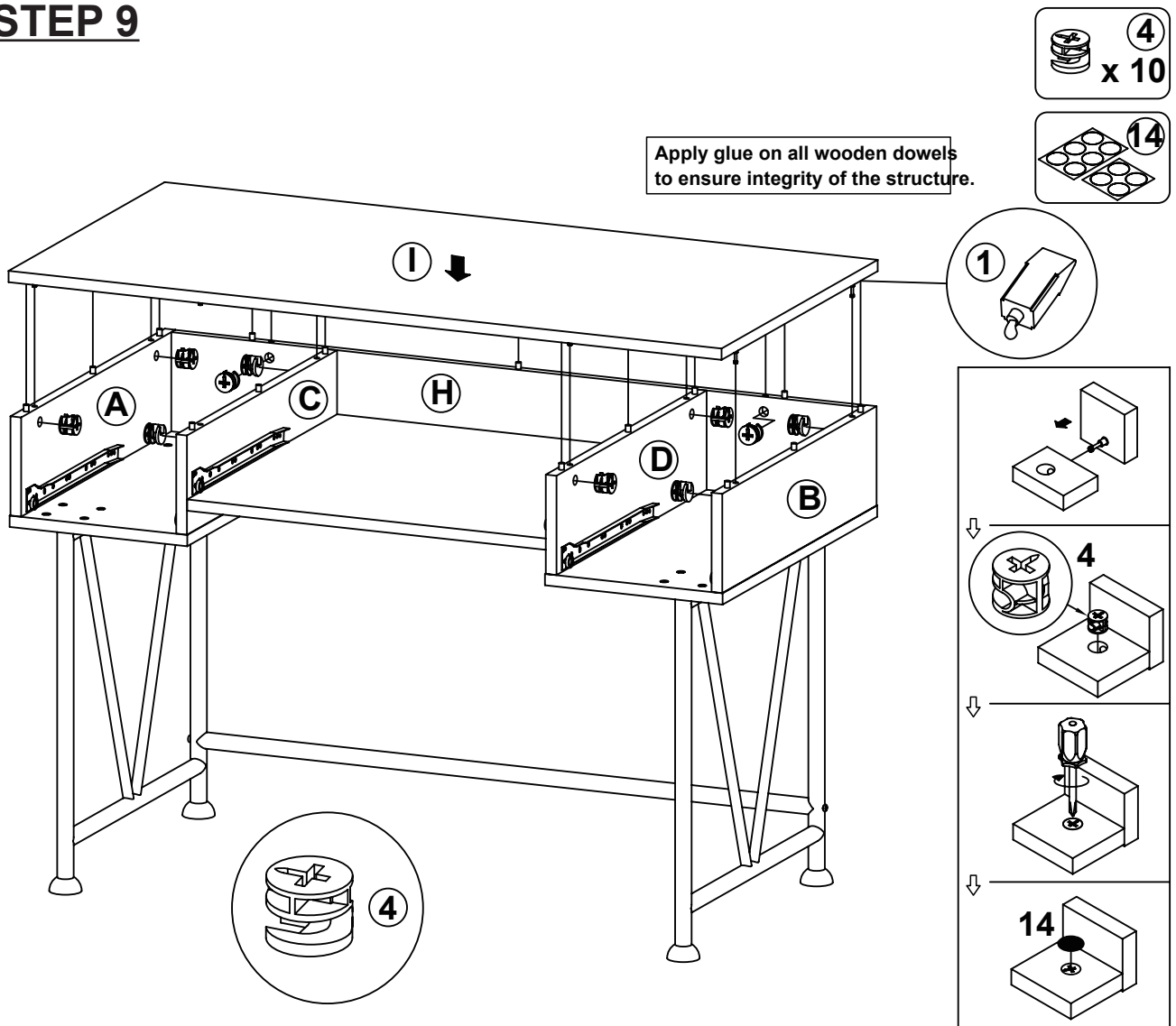

STEP 10-1

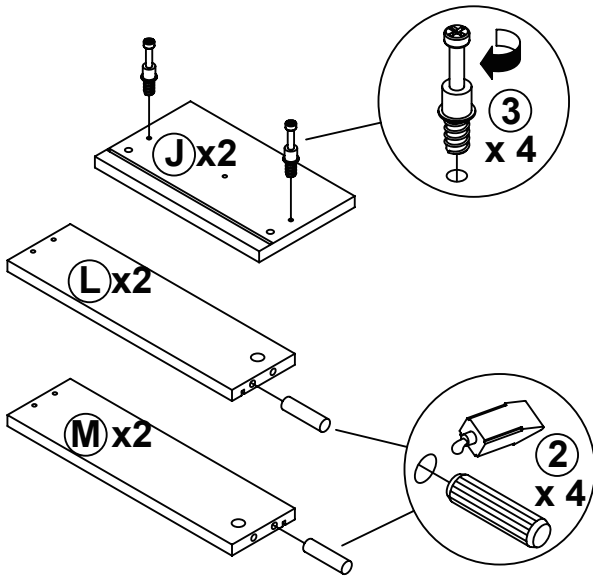

STEP 10-2

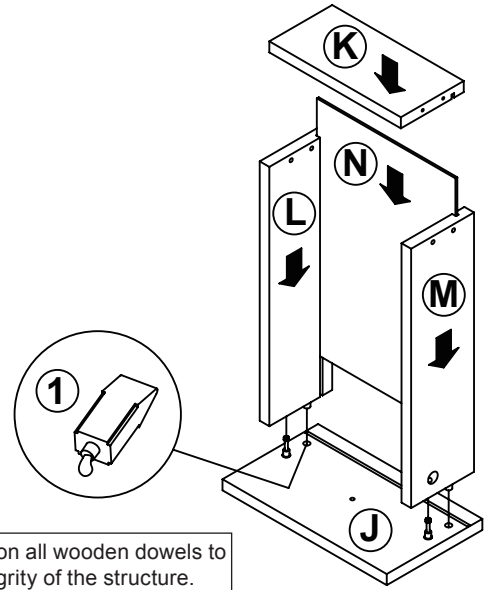

STEP 10-3

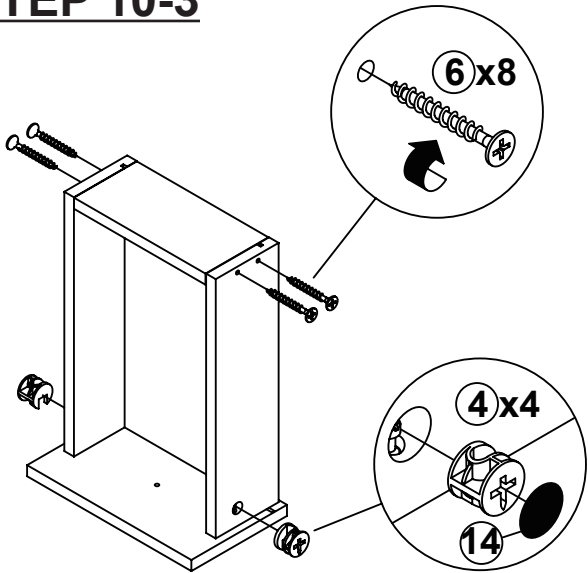

STEP 10-4

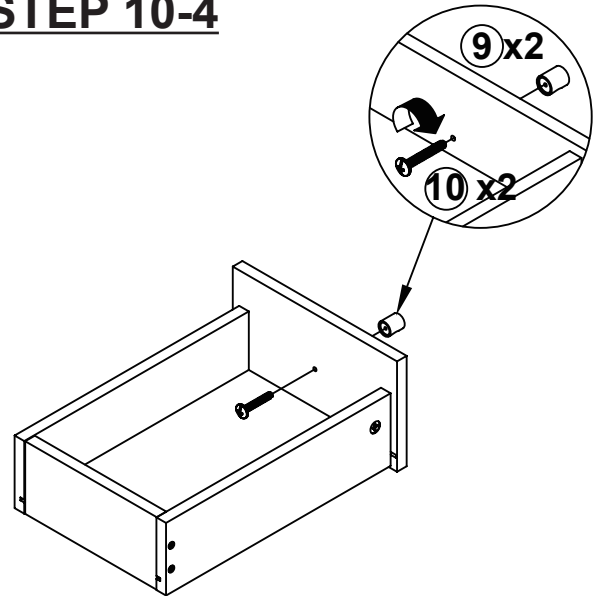

STEP 10-5

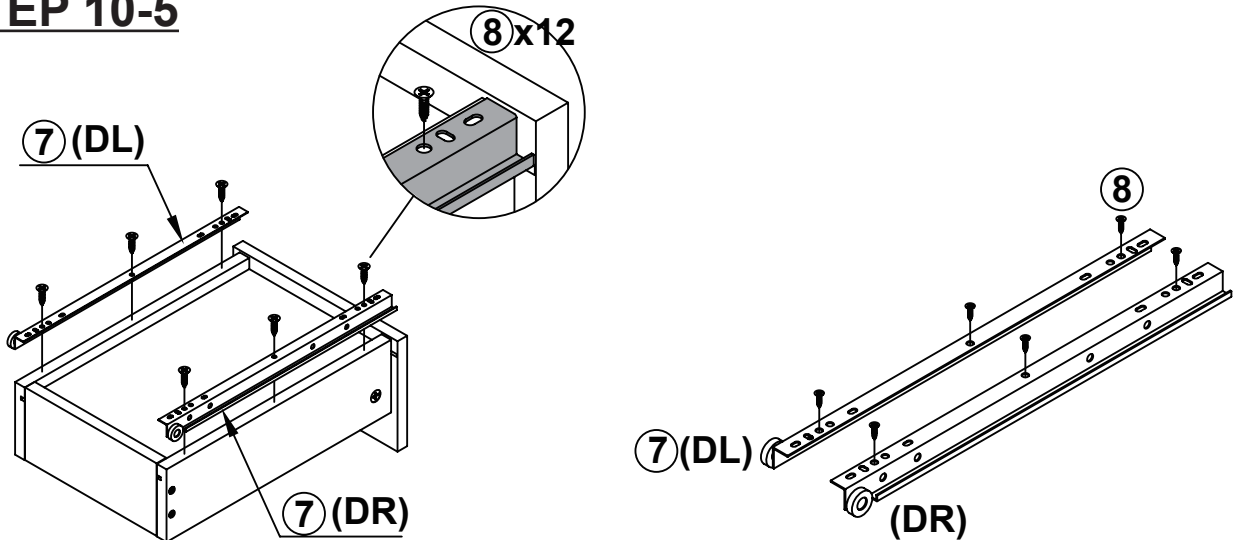

STEP 11-1

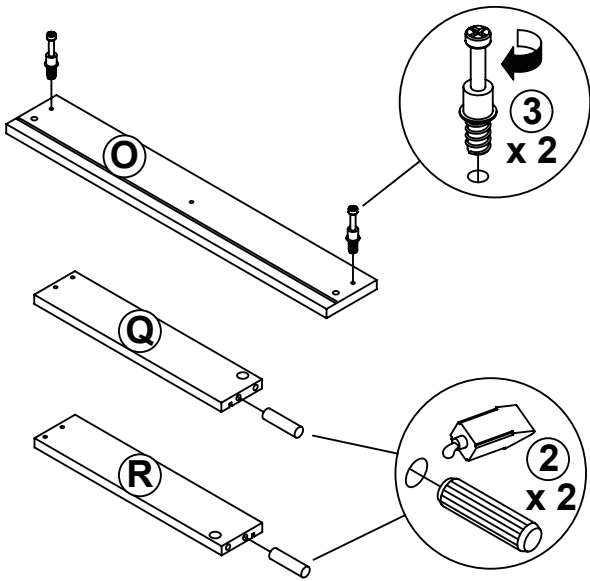

STEP 11-2

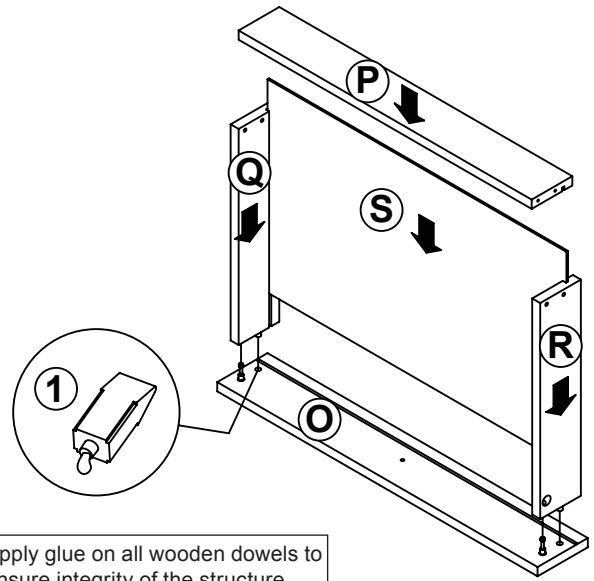

Apply glue on all wooden dowels to ensure integrity of the structure.

STEP 11-3

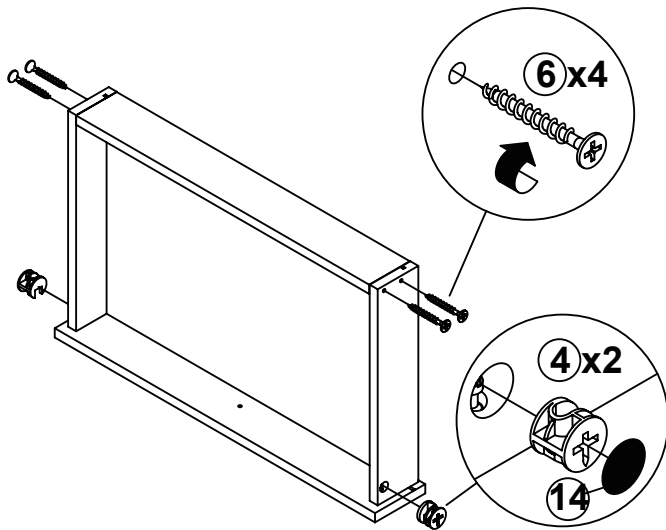

STEP 11-4

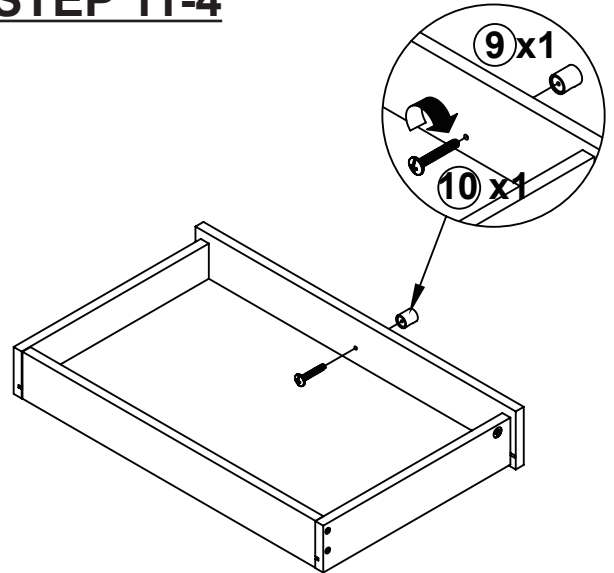

STEP 11-5

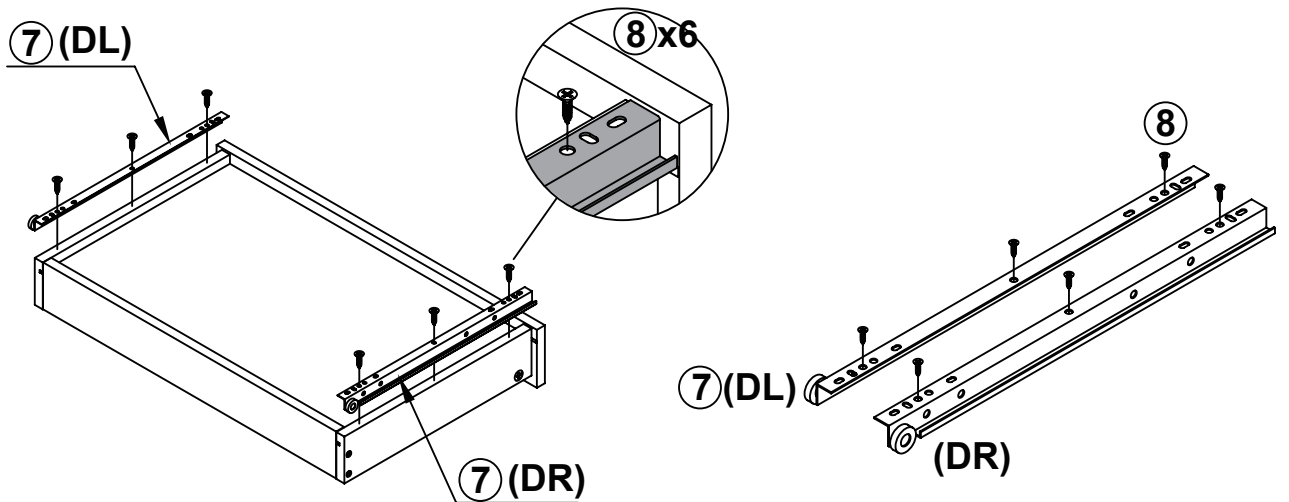

STEP 12

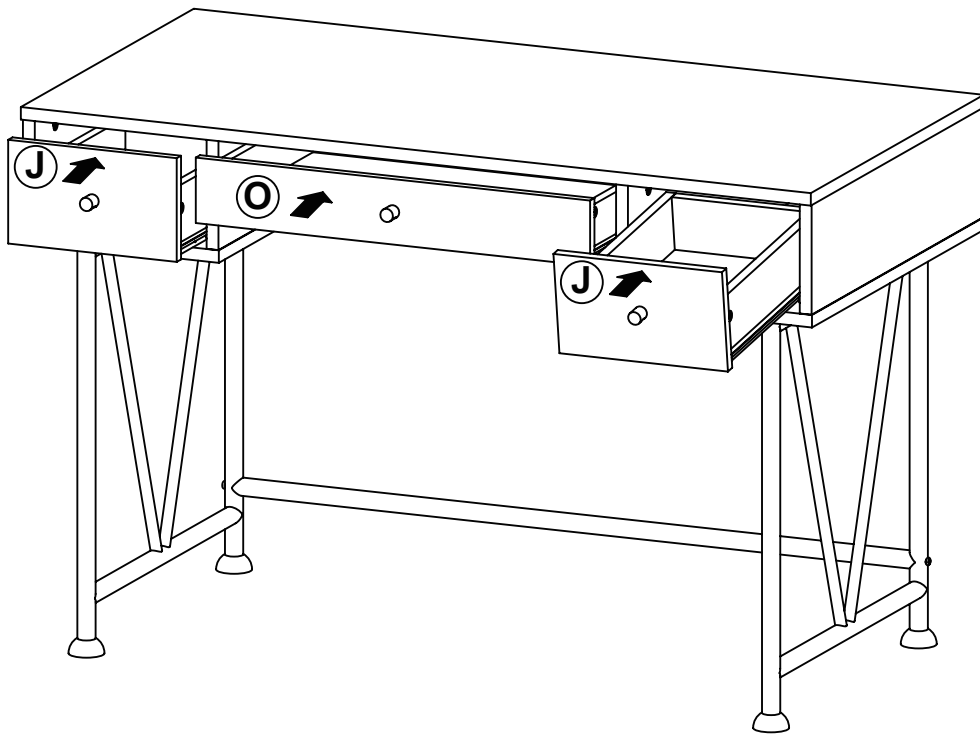

STEP 13 **COMPLETE**

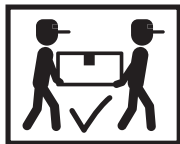
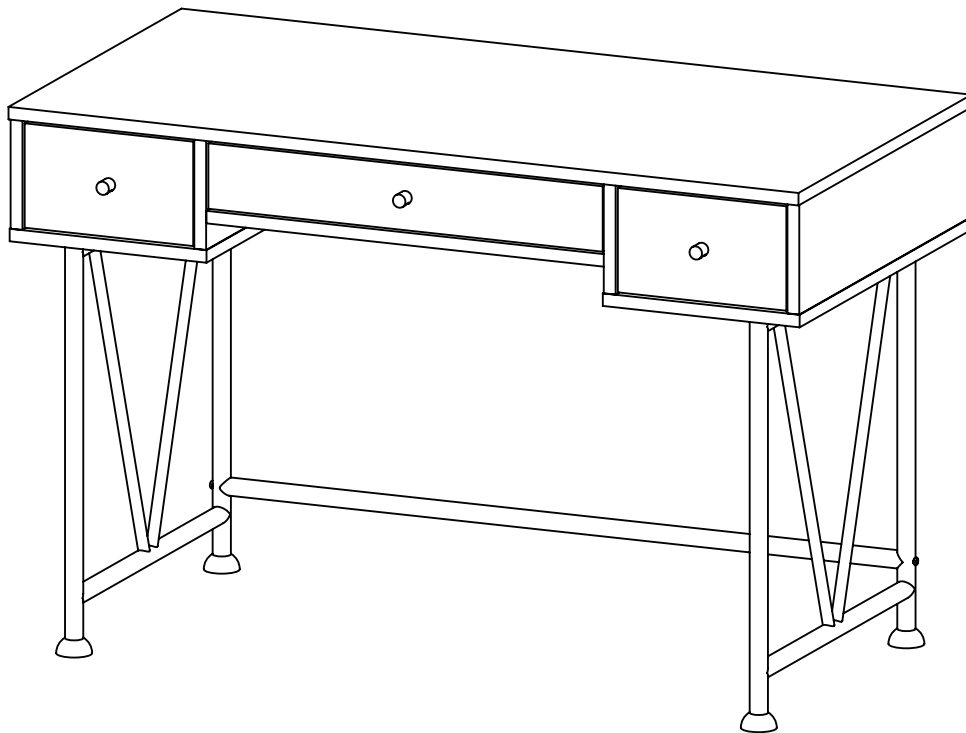

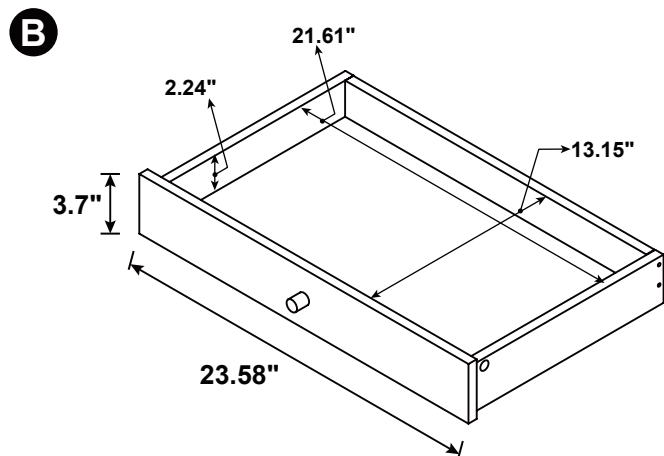
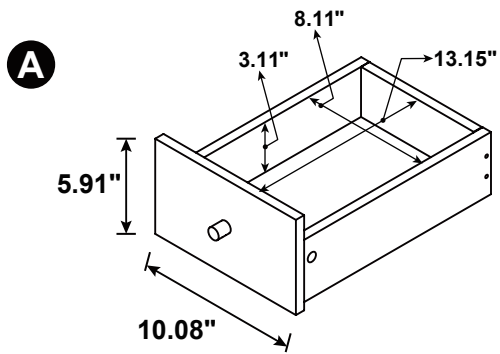
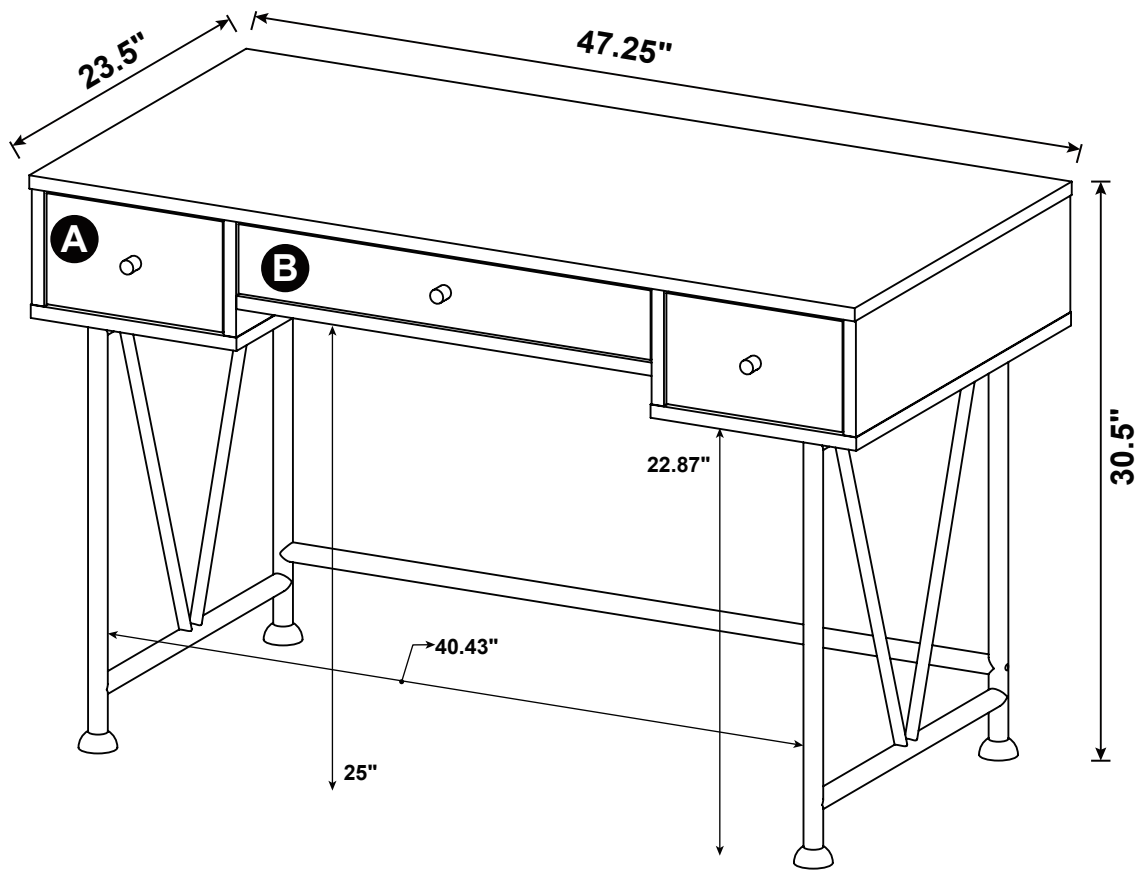

Note : Dimension tolerance $\pm 5\%$