

OWNER MANUAL

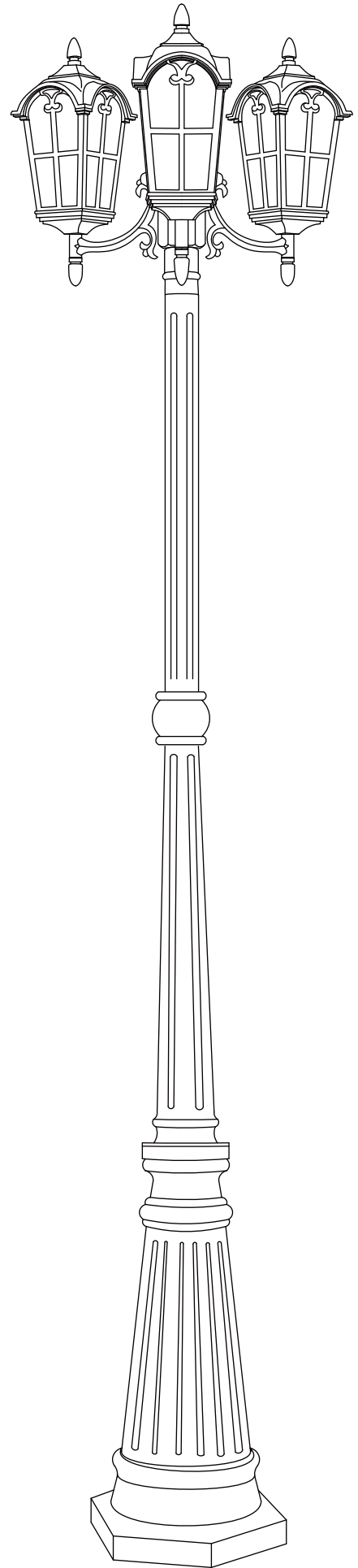

ASSEMBLY INSTRUCTIONS



IMPORTANT SAFETY INSTRUCTIONS SAVE THESE INSTRUCTIONS

INSTRUCTIONS PERTAINING TO RISK OF FIRE OR INJURY TO PERSONS READ ALL INSTRUCTIONS

Before starting the installation, disconnect the Power by Turning Off the Circuit Breaker. Use the light switch and Turn Off the Power to prevent electric shock. All electrical connections and installation must be following local codes, ordinances, and/or National Electric Code and Must Be Done by an Electrician Only.

TOOLS AND MATERIALS REQUIRED:



Phillips
Screwdriver



Wire Cutters



Pliers



Ladder

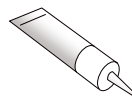

Mastic Silicone
Rubber



Safety Glasses

SAFETY PRECAUTIONS:

1. Turn off electrical power before starting the installation of the post light.
2. This product must be installed in accordance with the applicable installation code by a person familiar with the construction and operation of the product and the hazards involved.
3. Firmly attach the post light ground wire (bare copper) to the mounting bracket with the ground screw (by wrapping around the ground screw) and then connect it to the house supply ground wire with a wire nut.
4. To clean the post light, turn off the power, wait for it to cool, and wipe the post light with a clean, soft cloth.

Note: the product may not look exactly as shown in the figures.

Product Details :

Operation Temperature:	-20~50 °C
Product Dimensions	22"L x 8.8"W x 77.6"H
Material:	Aluminum
Waterproof:	Weather Resistant
Glass Material:	Tempered Glass
Voltage:	110-120V AC
Power Source:	Hard-wired
Wattage:	Max: 100W × 3
Bulb Base:	E26 X 3
Special Features:	Dusk To Dawn Sensor

Note: all specifications are for reference only and are subject to change without prior notice.

1 YEAR LIMITED WARRANTY*

This warranty against defects in material and quality for 1 year from the purchase date. This warranty does not cover acts of nature such as lightning damage or corrosion and discoloration of components. Nor does it cover damages caused through abuse, improper installation, surges in electric current, or acts of third parties.

This warranty does not cover the costs of removing and resealing the lighting fixture.

If this product falls for any reason covered by this warranty, feel free to contact us.

THREE-HEAD POST LIGHT INSTALLATION MANUAL

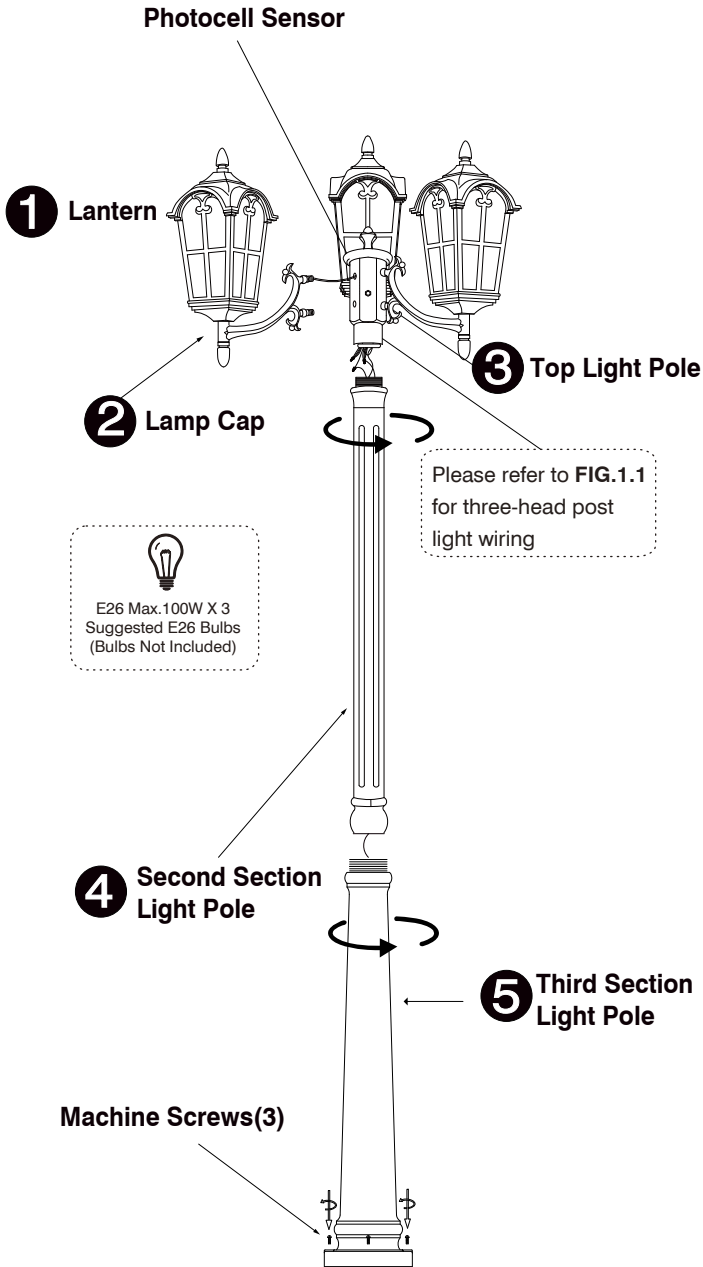

For base installation details, please refer to FIG.2A on page 7

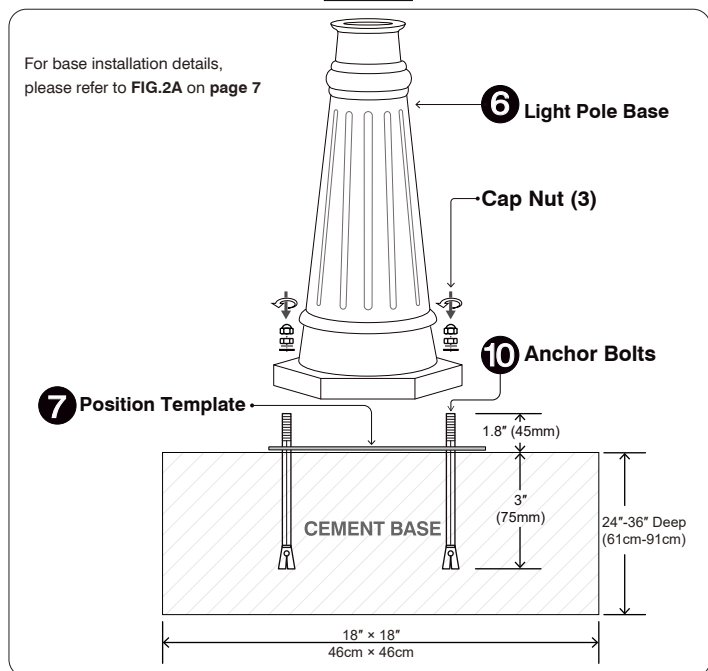

ASSEMBLY INSTRUCTIONS

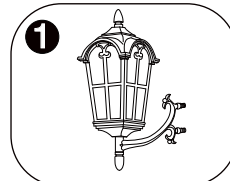

Lantern × 3

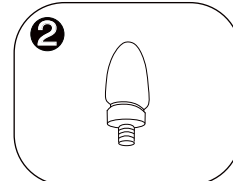

Lamp Cap × 3

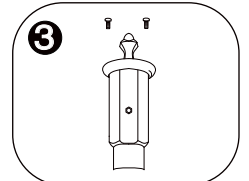

Top Light Pole
× 1
(With Photocell Sensor)

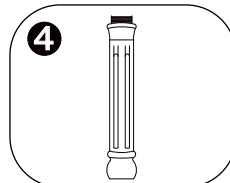

Second Section
Light Pole
× 1

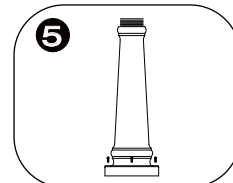

Third Section
Light Pole
× 1

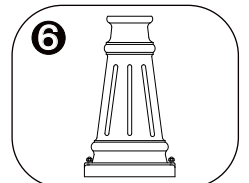

Light Pole Base
× 1

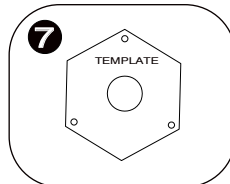

Position Template
× 1

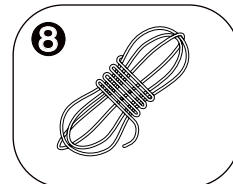

Long White Line
× 1

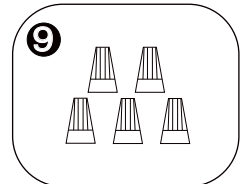

Wire Nuts
× 5

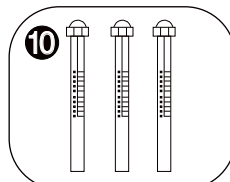

Anchor Bolt
× 3

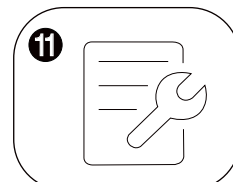

Installation Manual
× 1

Product List

- (**1**) Lantern + (**2**) Lamp Cap × 3
- (**3**) Top Light Pole × 1
(With Photocell Sensor)
- (**4**) Second Section Light Pole × 1
- (**5**) Third Section Light Pole × 1
- (**6**) Light Pole Base × 1
- (**7**) Position Template × 1
- (**8**) Long White Line × 1
- (**9**) Wire Nuts × 5
- (**10**) Anchor Bolt × 3
- (**11**) Installation Manual × 1

CONNECT TRIPLE-HEADED POST LIGHTS

Checklist Needed To Install:

1

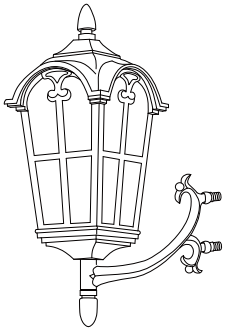

Lantern × 3

2

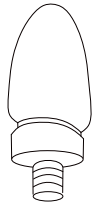

Lamp Cap × 3

3

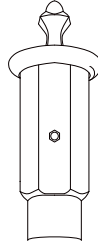

Top Light Pole × 1
(With Photocell Sensor)

8

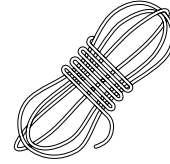

Long White Line
× 1

9

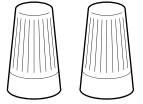

Wire Nuts
× 2

1 lantern

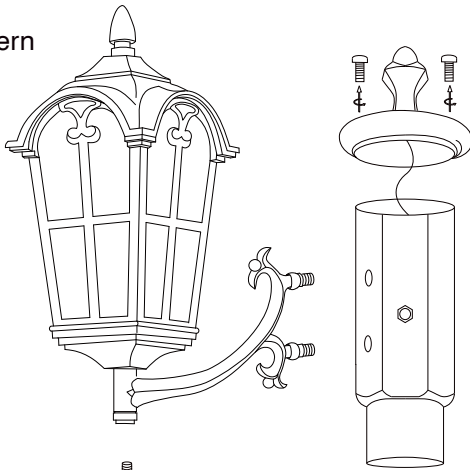

2 lamp cap



Disassemble The Top Light Pole

1. Tighten the (2) lamp cap on the (1) lantern).
2. Disassemble (3) The Top Light Pole (With Photocell Sensor)) and pull out the built-in 4 wires from the bottom of the top light pole (long black line×1, red line×1, white line×1, ground wire×1).

There is 1 screw & 2 wires
(white wire and black wire),
the screw needs to be
unscrewed in advance

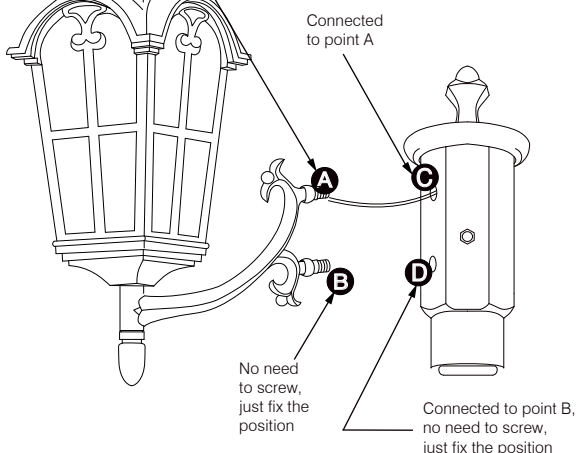

Connected to point A

No need to screw,
just fix the position

Connected to point B,
no need to screw,
just fix the position

Assemble 3 Lanterns

3. Unscrew the screw on the lantern arm (A) (only one screw (A)), Put the (white wire and black wire) of (A) into the top light pole through (C), match A to (C), match B to (D), and tighten the screw of (A) through Top Light Pole. (Tips: no screws need to be screwed at (B), just fixed the lantern).

CONNECT THE TOP LIGHT POLE WIRES

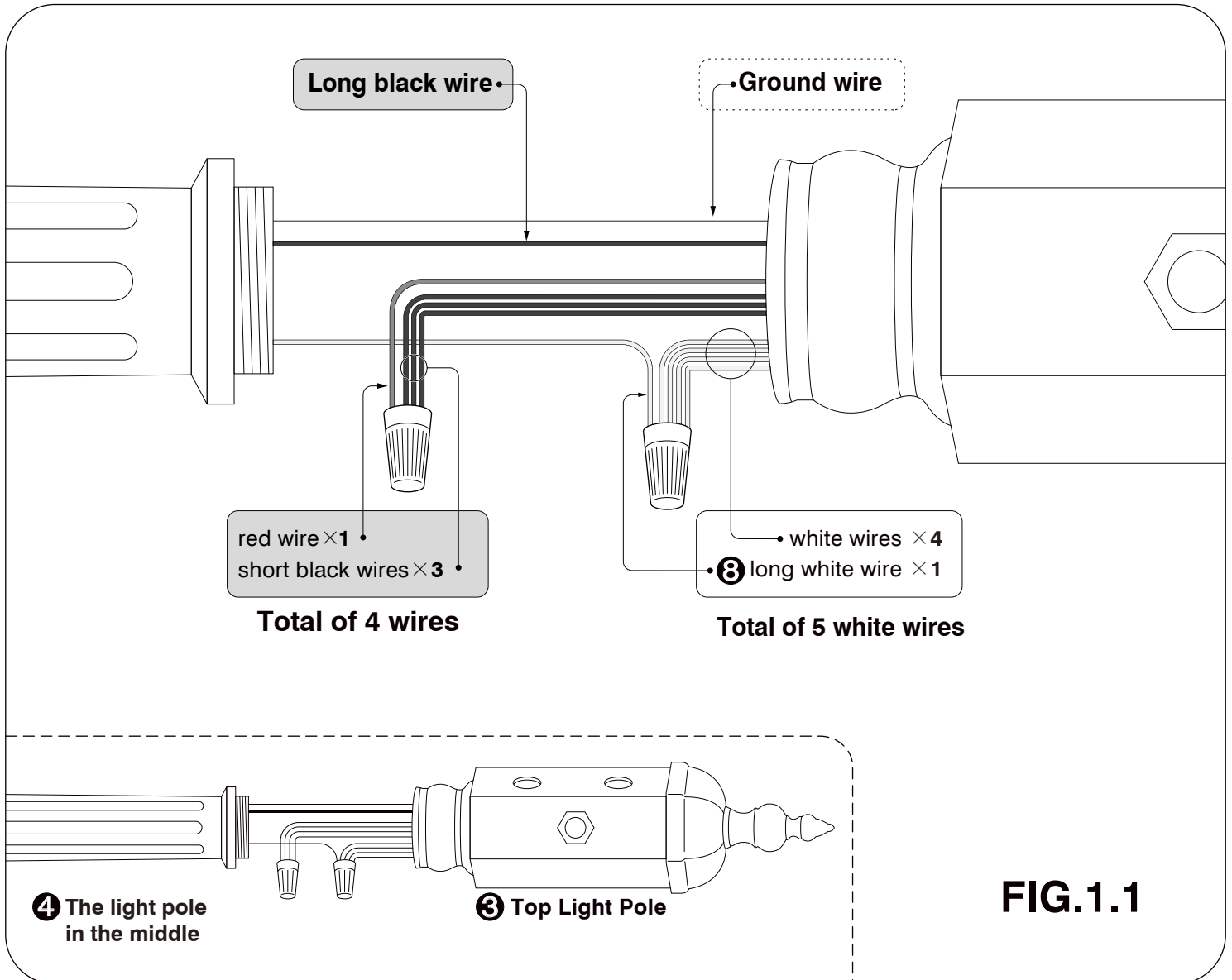

4. Connect 3 lamp holders in turn, each lantern has 2 wires (black wire × 1, white wire × 1).
5. Connect the 4 white wires and attached (⑧ long white wire (UL certified)) with a (⑨ wire nut) 5 white wires in total.
6. Connect 3 short black wires and 1 red wire (control Photocell sensor) with a (⑨ wire nut).
Note: A long black wire is left, no need to connect at present.
7. Assemble the dismantled top light pole, there should be 3 wires: long black wire × 1, ground wire × 1, long white wire × 1.
8. Assemble the bulbs: put the bulbs into the lantern in turn (bulbs are not included).

CONNECT LIGHT POLE

Checklist Needed To Install:

3

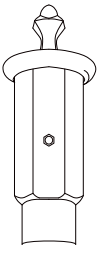

Top Light Pole ×1
(With Photocell Sensor)

4

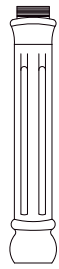

Second Section
Light Pole
×1

5

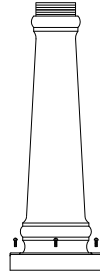

Third Section
Light Pole
×1

6

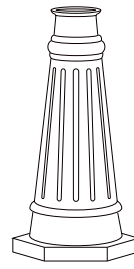

Light Pole Base
×1

9

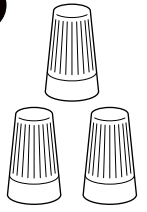

Wire Nuts
×3

Connect The Light Poles In Turn

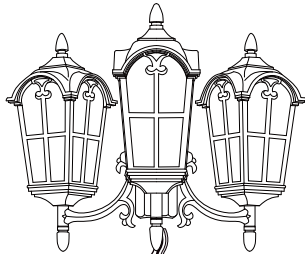

4 Second Section
Light Pole



5 Third Section
Light Pole

6 Light Pole Base

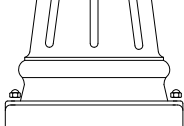
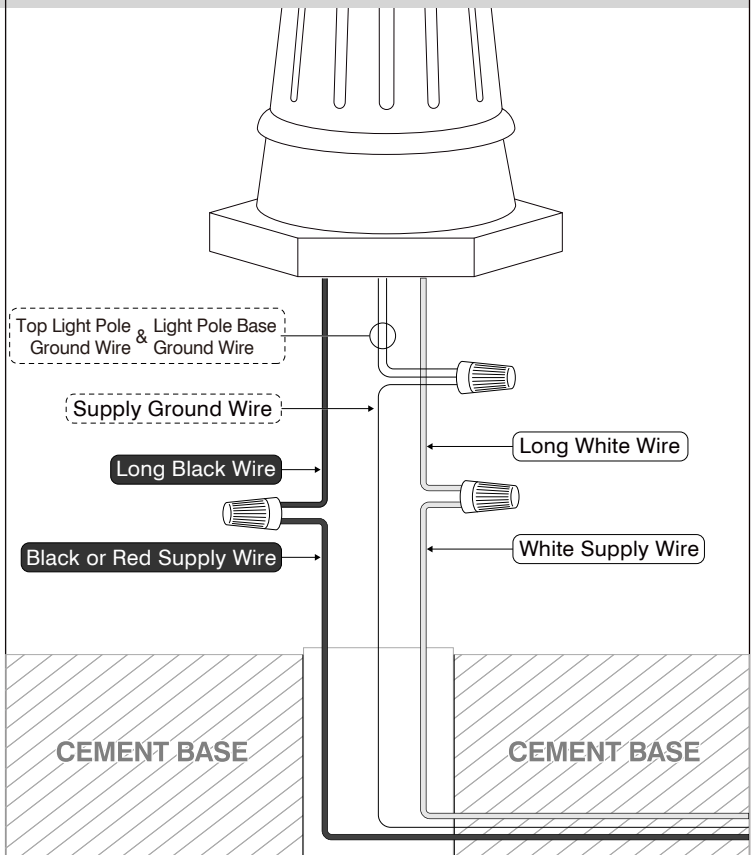

FIG.1.2

Connecting The Power Supply



Connect wires according to the below chart

Connect Black or Red Supply Wire to:	Connect White Supply Wire:
Black	White
*Parallel cord (round & smooth)	*Parallel cord (square & ridged)
Clear,Brown,Gold or Black without tracer	Clear,Brown,Gold or Black with tracer
Insulated wire (other than green) with copper conductor	Insulated wire (other than green) with silver conductor

*Note: When parallel wires are used. The neutral wire is square shapec or ridged and the other wire will be round in shape or smooth.

STEPS TO INSTALL THE LIGHT POLE BASE

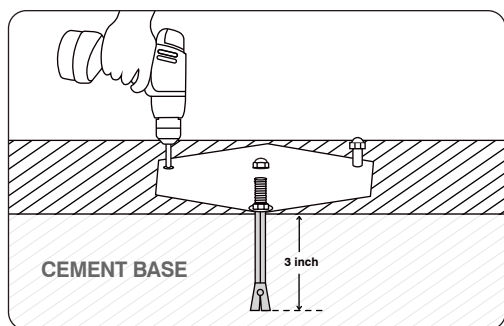

FIG.1

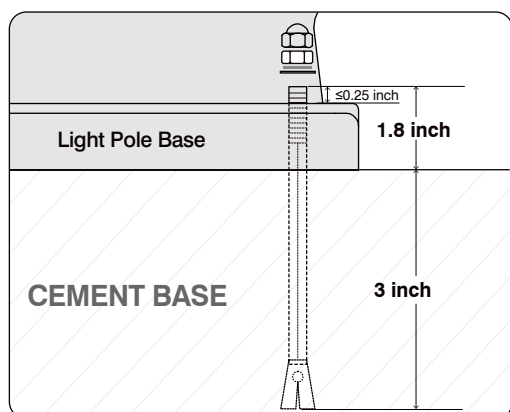

FIG.2

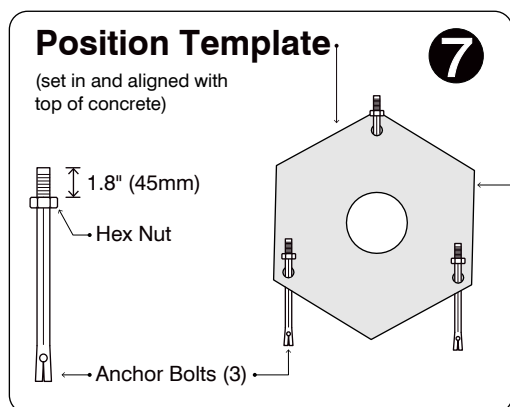
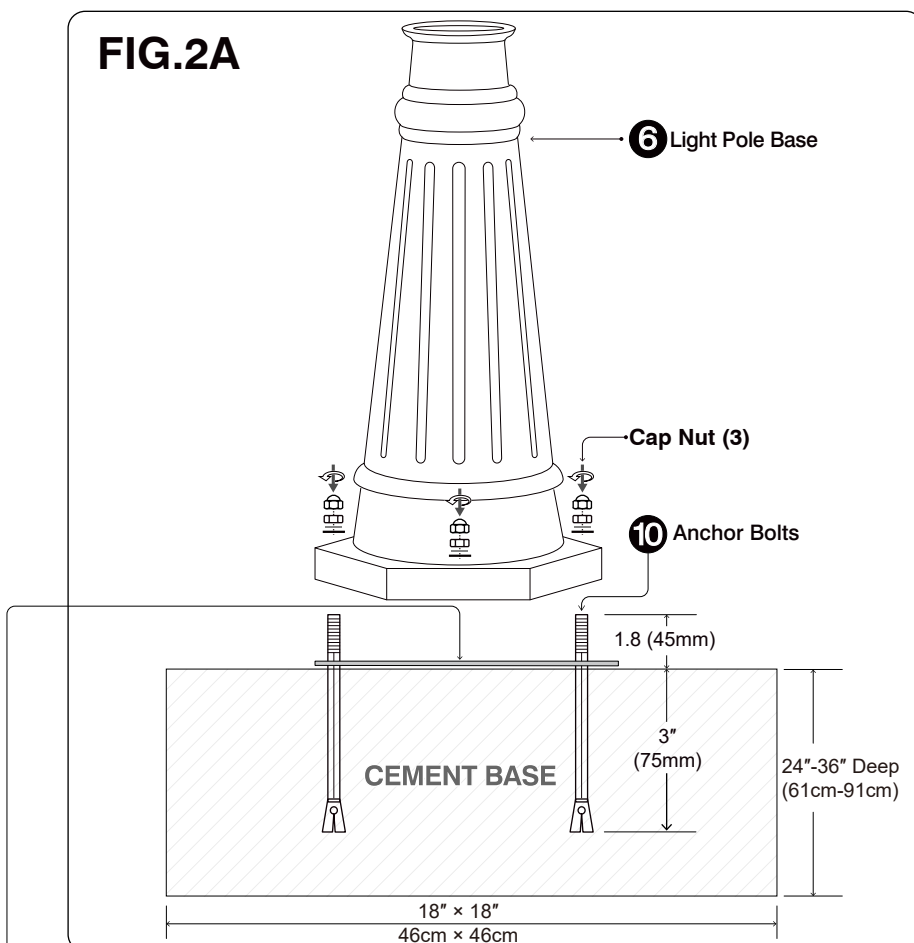

FIG.3

FIG.2A



1. Drilling holes in the concrete floor using an electric drill (the specific position can be fixed with the 7 Position Template), the drill depth is about 3 inches. (FIG.1)
2. Install the expansion screws into the corresponding holes, leaving about 1.8 inches. (FIG.2)
3. Install the base in the corresponding hole of the expansion screw. (FIG.3)
4. Finished after the screw is tightened.

Installation Steps:

1. Attach all three (3) **Anchor Bolts** to the **Position Pemplate**. Place the **Hex Nuts** over the **Position Template** to secure it in place. The threaded portion of the **Anchor Bolts** should extend 1.8" (45mm) from the position template, as illustrated in FIG.3. After the **Anchor Bolts** and **Position Template** are embedded and fixed in the **CEMENT BASE**, remove the **Hex Nut**.
2. The **CEMENT BASE** should have a minimum width of 18" (46cm) and a depth of 24" -36" (61-91cm), depending on the frost line in your area. Ensure that the **Anchor Bolts** protrude 1.8" (45mm) from the cement surface. as illustrated in FIG.2A.
3. Once the cement has fully dried, position the **Light Pole Base** onto the **Anchor Bolts** and thread the electrical wire through the designated hole.
4. Secure the light pole base to the concrete by tightening three (3) **Cap nuts** onto the **Anchor Bolts**, as illustrated in FIG.2A.
5. Please note that after the **Light Pole Base** is placed in the **CEMENT BASE**, the height from the **Anchor Bolts** to the **Light Pole Base** should not exceed 0.25" (6.5mm) , as illustrated in FIG.2.