

IMPORTANT NOTICE:
Storing and opening the leaf requires 2 people.

ASSEMBLY INSTRUCTIONS

Thank you for purchasing this quality product. Be sure to check all packaging materials carefully for small parts that may have come loose inside the carton during shipment.



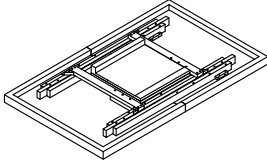
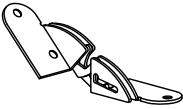
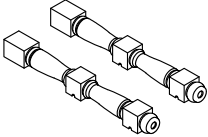
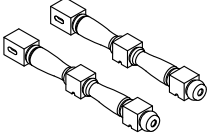
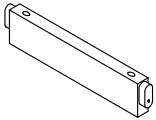
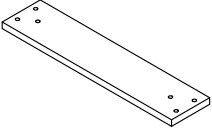
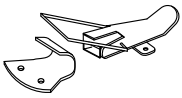
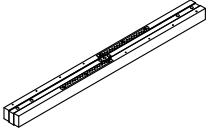
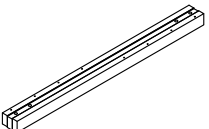
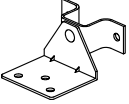
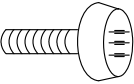

Reminders

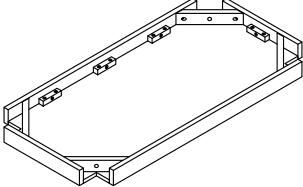
1. Use only the hardware supplied.
2. Do not over-tighten bolts.
3. This item may require periodic tightening.

		COMPONENTS LIST	QTY
A	Table Top		1pc
B	Leaf Hinge		2pcs
C-1	Left Table Legs		2pcs
C-2	Right Table Legs		2pcs
D	Stretcher		2pcs
E	Mounting Plate		2pcs
F	Clamp Lock		4pcs
G	Gear Driven Glide		1pc
H	Wood Glide		1pc
I	Support Leaf Hinge		2pcs
J	Adjustable Leveler		4pcs

		COMPONENTS LIST	QTY
K	BOTTOM SHELF		2pcs

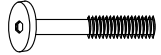
Hardware List :

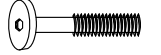
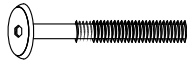
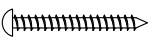
NO	DESCRIPTION	SIZE	FIGURE	QTY
1	Flat Washer	Ø5/16"x 19mm		20pcs
2	Spring Washer	Ø5/16"x 12mm		20pcs
3	Short Bolt	Ø1/4"x75mm		8pcs
4	Allen Key	58x 23x 4mm		1pc
5	Short Bolt	Ø5/16"x 45mm		4pcs
6	Long Bolt	Ø5/16"x 64mm		8pcs
7	Screw	Ø8x 50mm		4pcs

IMPORTANT NOTE:
- Please keep all hardware parts out of the reach of children.
- Two or more people are needed for assembly.

ASSEMBLY INSTRUCTIONS

STEP 1:

Attach Table Legs (C-1 & C-2) to the Stretchers using the provided hardware as shown in Fig.1.

Attach bottom shelves (K) to Table legs (C-1 & C-2) using the provided hardware as shown in Fig. 2

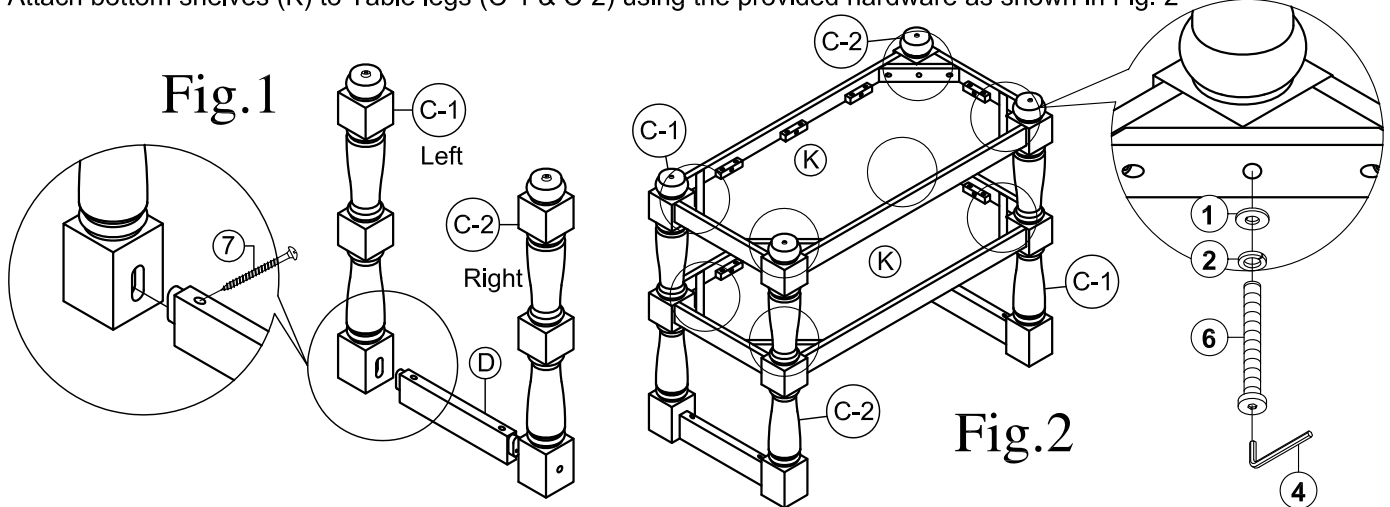

STEP 2:

Attach Mounting Plate (E) to the Table legs (C-1 and C-2) using the provided hardware as shown in Fig. 3.

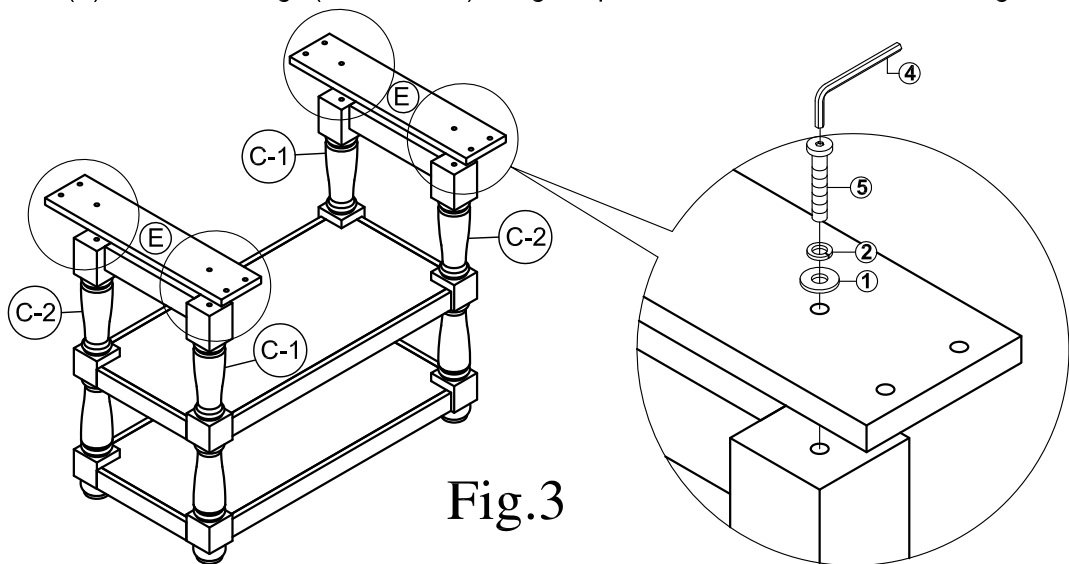

STEP 3:

Place table top (A) upside down on a smooth and flat surface.

Attach Mounting Plate (E) to the Table Top (A), using the provided hardware as shown in Fig. 4.

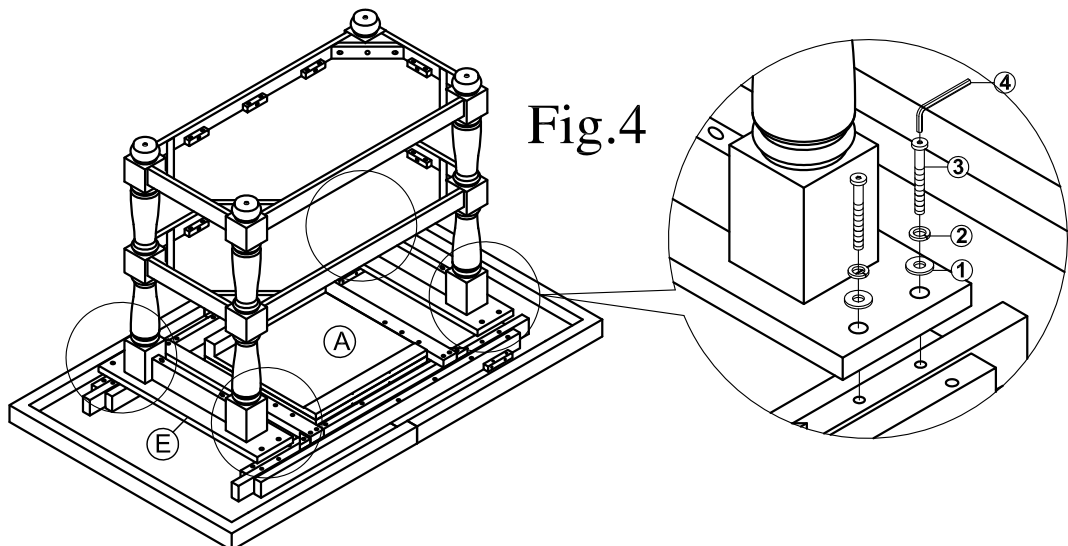

ASSEMBLY INSTRUCTIONS

STEP 4:

- Turn the table to the upright position.
- Pull the Table Top (A) from both ends and open the table leaf which is stored underneath the table top.
- Close the table top by pushing from both ends and clamp lock the latch underneath the table top to prevent from sliding.
- Please put your hand in the place as shown in the illustration when pick up the butterfly leaf to avoid injury

