



Manufactured by:
Backyard Discovery
3305 Airport Drive, Pittsburg, KS 66762
800-856-4445

Basepoint Business Centre: Rivermead Drive, Westlea, Swindon SN5 7EX Phone: 0800-118-2476

J.P. Coenstraat 7, The Bridge, The Hague, 2595 WP, Netherlands Phone: 08005678990

CEDAR COVE

SWING SET

MODEL: # 2101067, 2400023



WARNING

Adult Assembly Required.

The assembly manual must be retained since it contains important information
Not suitable for children under 36 months due to small parts.

FOR DOMESTIC USE ONLY. INTENDED FOR OUTDOOR USE.



Please visit www.backyarddiscovery.com

For the most up to date assembly manual, to register your product, or to order replacement parts

Para obtener instrucciones en español, visite www.backyarddiscovery.com



EASY STEP-BY-STEP
3D INTERACTIVE INSTRUCTIONS
DOWNLOAD THE FREE APP



Made in China

INS-2101067, 2400023-A-CEDAR COVE-ENG 10-25-23



Place the set on level ground, not less than 6'-7" [2 m] from any structure or obstruction such as a fence, garage, house, overhanging branches, laundry lines, or electrical wires.

- While assembling unit, take time before and after each phase to make sure fort is level. If fort is not level, assembly will be difficult and improper assembly may result. Extra care must be taken to insure the fort is square.
- The safe play area refers to a zone extending 6'-7" (2m) beyond the play product on all sides, including the space above the play product.

SAFE PLAY AREA DIAGRAM

Ground Dimension

18' - 4 3/8" (5.6m) x 15' - 3 3/8" (4.7m) x 9' - 11 3/8" (3m)

Safe Play Area

31' - 6 3/8" (9.6m) x 28' - 5 1/4" (8.7m)

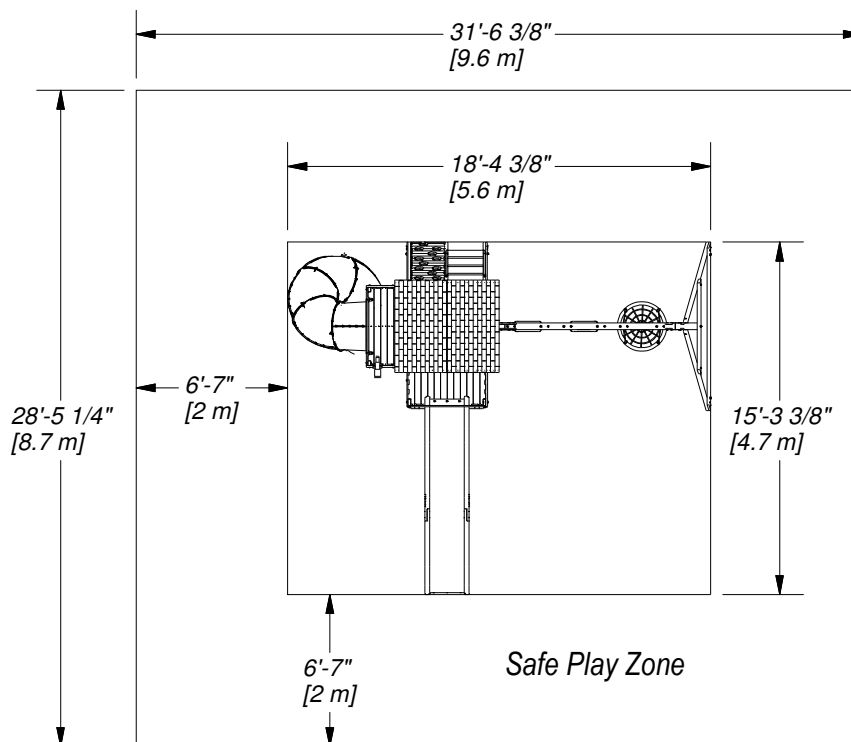

SAFE PLAY HEIGHT: 16'-6 3/8" [3.0 m]
MAXIMUM FALL HEIGHT: 6'-3 5/8" [1.9 m]

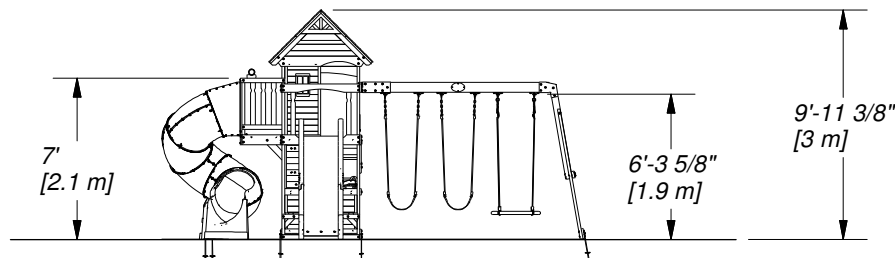

General Information:

Your set has been designed and engineered for children only and for residential use only.
 A maximum of 150 lbs. per child is recommended for play activities designed for individual use.
 A maximum of 120 lbs. per child is recommended for play activities designed for multiple child use.
 A maximum of 9 children is recommended for this swing set.



Wood Components (Not to Scale)



A1 | SWING BEAM - W4L13335
(x1) | 3 3/8"x5 1/4"x89 1/2" (86x134x2274)

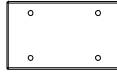

A2 | SB 9" BLOCK - W4L13337
(x1) | 3 3/8"x5 1/4"x9" (86x134x228)



E2 | UPRIGHT - W4L13166
(x1) | 1 3/8"x3 3/8"x51 3/4" (36x86x1314)



E3 | UPRIGHT - W4L13167
(x1) | 1 3/8"x3 3/8"x51 3/4" (36x86x1314)

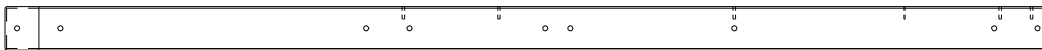

E4 | UPRIGHT - W4L13168
(x1) | 1 3/8"x3 3/8"x81 5/8" (36x86x2074)



E5 | UPRIGHT - W4L13175
(x1) | 1 3/8"x3 3/8"x80 3/4" (36x86x2052)

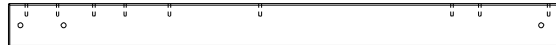

E6 | UPRIGHT - W4L13182
(x1) | 1 3/8"x3 3/8"x43 1/2" (36x86x1104)

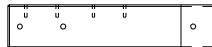

E7 | UPRIGHT - W4L13183
(x1) | 1 3/8"x3 3/8"x16 1/8" (36x86x411)



E8 | UPRIGHT - W4L13184
(x1) | 1 3/8"x3 3/8"x43 1/2" (36x86x1104)



E9 | UPRIGHT - W4L13185
(x1) | 1 3/8"x3 3/8"x16 1/8" (36x86x411)



E11 | UPRIGHT - W4L13203
(x1) | 1 3/8"x3 3/8"x80 3/4" (36x86x2052)



E13 | DECK BRACE - W4L13314
(x1) | 1 3/8"x3 3/8"x23 5/8" (36x86x600)



E14 | DECK BRACE - W4L13315
(x1) | 1 3/8"x3 3/8"x23 5/8" (36x86x600)



Wood Components (Not to Scale)



E15 | LEFT UPRIGHT - W4L13322
(x1) | 1 3/8"x3 3/8"x56 3/4" (36x86x1441)



E16 | MIDDLE UPRIGHT - W4L13323
(x1) | 1 3/8"x3 3/8"x56 3/4" (36x86x1441)



E17 | RIGHT UPRIGHT - W4L13327
(x1) | 1 3/8"x3 3/8"x56 3/4" (36x86x1441)

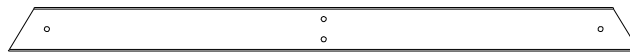

E50 | END SUPPORT - W4L13208
(x1) | 1 7/16"x3 3/8"x49 1/4" (36x86x1251)

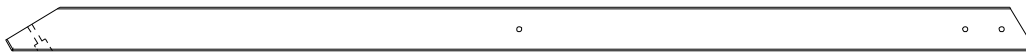

E51 | ANGLE BRACE - W4L13206
(x2) | 1 7/16"x3 3/8"x80 1/2" (36x86x2045)



F1 | TUBE SLIDE MOUNT - W4L13179
(x2) | 1 3/8"x2 3/8"x29 3/8" (36x60x747)



F2 | BALCONY UPRIGHT - W4L13180
(x2) | 1 3/8"x2 3/8"x34 5/8" (36x60x881)



G1 | SWING BEAM MOUNT - W4L13186
(x1) | 1"x5 1/4"x62 1/8" (24x134x1577)



G2 | WALL RAIL - W4L13171
(x1) | 1"x5 1/4"x61 3/8" (24x134x1560)



G3 | WALL RAIL - W4L13170
(x1) | 1"x5 1/4"x61 3/8" (24x134x1560)



G4 | WALL BOARD - W4L13181
(x1) | 1"x5 1/4"x42 1/2" (24x134x1080)



G50 | GROUND BOARD - W4L13207
(x1) | 1"x5 1/4"x87 3/4" (24x134x2230)



Wood Components (Not to Scale)



H1 | ATTACHMENT BOARD - W4L13326
(x1) | 1"x3 3/8"x40 1/2" (24x86x1030)



H2 | UPRIGHT - W4L13338
(x2) | 1"x2 3/4"x55 7/8" (24x70x1419)



H3 | DECK BRACE - W4L13202
(x2) | 1"x3 3/8"x15 3/4" (24x86x400)



H4 | DECK BRACE - W4L13205
(x2) | 1"x3 3/8"x15 3/4" (24x86x400)



H16 | LADDER RUNG - W4L13324
(x4) | 1"x3 3/8"x19 1/4" (24x86x489)



H80 | SLIDE BRACE WIDE - W4L15715
(x1) | 1"x3 3/8"x18 3/8" (24x86x466)



H83 | SLIDE BRACE - W4L13333
(x2) | 1"x3 3/8"x20 1/8" (24x86x512)



J1 | PORCH GROUND BOARD - W4L13177
(x1) | 1"x2 3/8"x40 1/2" (24x60x1030)



J2 | PORCH GROUND BOARD - W4L13178
(x1) | 1"x2 3/8"x40 1/2" (24x60x1030)



J3 | BENCH SUPPORT - W4L13196
(x2) | 1"x2 3/8"x9" (24x60x230)



J4 | ANGLE BRACE - W4L13197
(x2) | 1"x2 3/8"x10" (24x60x254)



J5 | SUPPORT BLOCK - W4L13198
(x2) | 1"x2 3/8"x2 7/8" (24x60x72)



J6 | SUPPORT BLOCK - W4L13199
(x2) | 1"x2 3/8"x6 1/4" (24x60x160)



J7 | WALL RAIL - W4L13191
(x1) | 1"x2 3/8"x40 5/8" (24x60x1032)



J8 | FLOOR JOIST - W4L07602
(x1) | 1"x2 3/8"x40 1/2" (24x60x1029)



J9 | FLOOR JOIST - W4L07603
(x1) | 1"x2 3/8"x20 1/4" (24x60x513)



J10 | SUPPORT BOARD - W4L13321
(x1) | 1"x2 3/8"x2 3/8" (24x60x60)



J11 | WALL RAIL - W4L13204
(x2) | 1"x2 3/8"x22 1/4" (24x60x566)



J12 | WALL RAIL - W4L13188
(x2) | 1"x2 3/8"x23 1/4" (24x60x590)



K1 | GROUND BOARD - W4L13162
(x1) | 5/8"x5 1/4"x64 3/4" (16x134x1644)

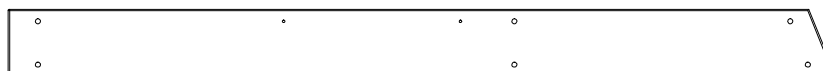

K2 | GROUND BOARD - W4L13163
(x1) | 5/8"x5 1/4"x64 11/16" (16x134x1644)



Wood Components (Not to Scale)



K3 | GROUND BOARD - W4L13164
(x1) | 5/8"x5 1/4"x40 1/2" (16x134x1030)



K4 | GROUND BOARD - W4L13165
(x1) | 5/8"x5 1/4"x40 1/2" (16x134x1030)



K5 | WALL RAIL - W4L13169
(x1) | 5/8"x5 1/4"x63" (16x134x1601)



K6 | ARCHED WALL RAIL - W4L13190
(x1) | 5/8"x5 1/4"x40 1/2" (16x134x1030)

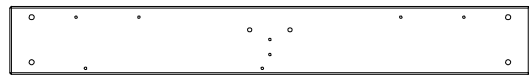

K8 | WALL RAIL - W4L13172
(x1) | 5/8"x5 1/4"x40 5/8" (16x134x1032)



K9 | WALL RAIL - W4L13173
(x1) | 5/8"x5 1/4"x20 1/2" (16x134x521)



K10 | WALL RAIL - W4L13174
(x1) | 5/8"x5 1/4"x40 1/2" (16x134x1030)



K12 | ARCHED WALL RAIL - W4L13192
(x1) | 5/8"x5 1/4"x40 5/8" (16x134x1032)



K13 | ARCHED WALL RAIL - W4L13193
(x1) | 5/8"x5 1/4"x40 5/8" (16x134x1032)



K14 | ANGLED WALL RAIL - W4L13194
(x1) | 5/8"x5 1/4"x45 3/4" (16x134x1162)



K15 | ANGLED WALL RAIL - W4L13195
(x1) | 5/8"x5 1/4"x45 3/4" (16x134x1162)



K16 | COUNTER TOP - W4L13316
(x1) | 5/8"x5 1/4"x37 1/4" (16x134x946)



K17 | FLOOR BOARD - W4L07596
(x2) | 5/8"x5 1/4"x21 1/8" (16x134x537)



K18 | COUNTER TOP - W4L13317
(x1) | 5/8"x5 1/4"x37 1/4" (16x134x946)



L1 | ARCHED WALL RAIL - W4L13187
(x1) | 5/8"x4 3/8"x40 1/2" (16x112x1030)



L3 | WALL RAIL - W4L13189
(x1) | 5/8"x4 3/8"x24 7/8" (16x112x631)

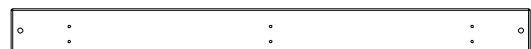

M1 | WALL RAIL - W4L13200
(x1) | 5/8"x3 3/8"x40 1/2" (16x86x1030)

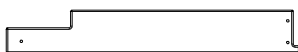

M2 | BENCH BOARD - W4L07591
(x2) | 5/8"x3 3/8"x23" (16x86x583)

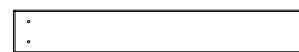

M3 | BENCH BOARD - W4L07593
(x2) | 5/8"x3 3/8"x23" (16x86x583)



Wood Components (Not to Scale)



M4 | FLOOR BOARD - W4L07597
(x9) | 5/8"x3 3/8"x21 1/8" (16x86x537)



M5 | WALL RAIL - W4L13311
(x1) | 5/8"x3 3/8"x41 1/4" (16x86x1048)



M6 | COUNTER TOP BOARD - W4L13318
(x1) | 5/8"x3 3/8"x28 5/8" (16x86x726)



M7 | FLOOR BOARD - W4L13305
(x1) | 5/8"x3 1/8"x19 7/8" (16x78x504)



M8 | FLOOR BOARD - W4L13304
(x1) | 5/8"x3 3/8"x19 7/8" (16x86x504)



M9 | FLOOR BOARD - W4L13306
(x10) | 5/8"x3 3/8"x19 7/8" (16x86x504)



M10 | FLOOR BOARD - W4L13310
(x1) | 5/8"x3 1/4"x40 5/8" (16x81x1031)

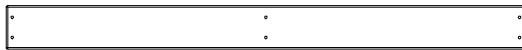

M11 | FLOOR BOARD - W4L13308
(x15) | 5/8"x3 3/8"x40 5/8" (16x86x1031)



M12 | REAR SUPPORT - W4L13325
(x1) | 5/8"x3 3/8"x21 1/4" (16x86x541)



M13 | ROCK BOARD - W4L13328
(x8) | 5/8"x3 3/8"x17 7/8" (16x86x453)



M14 | ROCK BOARD - W4L13329
(x4) | 5/8"x3 3/8"x17 7/8" (16x86x453)



M15 | ROCK BOARD - W4L13330
(x4) | 5/8"x3 3/8"x17 7/8" (16x86x453)

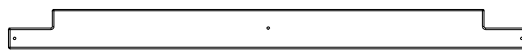

M16 | FLOOR BOARD - W4L13307
(x1) | 5/8"x3 1/8"x40 5/8" (16x78x1031)



M17 | FLOOR BOARD - W4L13309
(x1) | 5/8"x3 3/8"x40 5/8" (16x86x1031)



M70 | SLIDE BED SUPPORT - W100935
(x1) | 5/8"x3 3/8"x19 7/8" (16x86x505)



N1 | PORCH GROUND BOARD - W4L13176
(x2) | 5/8"x2 3/8"x21 1/8" (16x60x537)



N2 | PICKET - W4L07612
(x14) | 5/8"x2 3/8"x24 3/4" (16x60x628)



N3 | BENCH BOARD - W4L07592
(x2) | 5/8"x2 3/8"x23" (16x60x583)

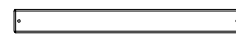

N4 | ROCK BOARD - W4L13331
(x1) | 5/8"x1 3/4"x17 7/8" (16x46x453)

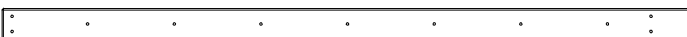

N5 | ROCKWALL CLEAT - W4L13332
(x1) | 5/8"x2 3/8"x53 7/8" (16x60x1370)



N6 | CLEAT - W4L13320
(x1) | 5/8"x2 3/8"x5 7/8" (16x60x150)



Q1 | COUNTER TOP SUPPORT - W4L13319
(x1) | 1"x4 3/8"x9 1/2" (24x112x240)



SP50 | SWING BEAM SUPPORT - W4L13336
(x1) | 3 3/8"x3 3/8"x49 3/8" (86x86x1254)



T1 | SUPPORT BOARD - W4L07599
(x3) | 1"x1 3/8"x37 5/8" (24x34x957)

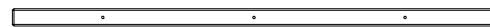

T2 | SUPPORT BOARD - W4L07600
(x1) | 1"x1 3/8"x37 3/4" (24x34x959)



T3 | SUPPORT BOARD - W4L07601
(x2) | 1"x1 3/8"x18 3/4" (24x34x477)



T4 | SUPPORT BOARD - W4L13312
(x1) | 1"x1 3/8"x33 3/4" (24x34x858)

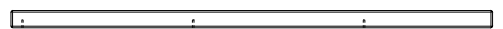

T5 | SUPPORT BOARD - W4L13313
(x1) | 1"x1 3/8"x37 5/8" (24x34x956)



Wood Components (Not to Scale)



WP1 | WALL PANEL - W2A02840
(x1) | 1"x20 3/8"x37 3/4" (24x517x956)



WP2 | WALL PANEL - W2A02841
(x1) | 1"x20 3/8"x37 3/4" (24x517x858)

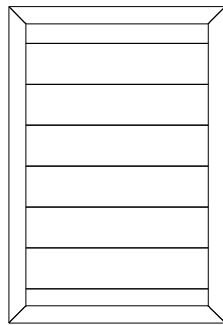

WP3 | WALL PANEL - W2A02849
(x2) | 1"x16 7/8"x24 5/8" (24x430x627)

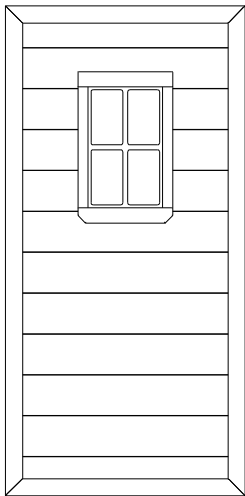

WP7 | WALL PANEL - W2A02088
(x1) | 1"x16 7/8"x46 1/2" (24x476x971)

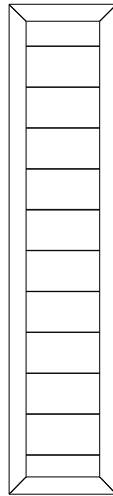

WP8 | WALL PANEL - W2A02089
(x2) | 1"x18 7/8"x11 3/4" (24x214x971)

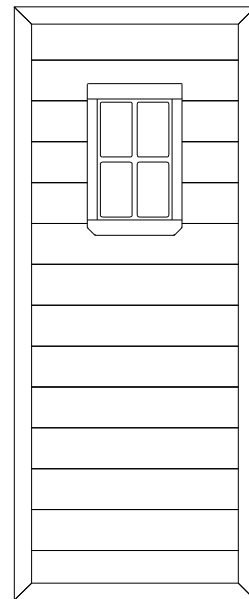

WP9 | WALL PANEL - W2A02090
(x1) | 1"x16 7/8"x46 1/2" (24x479x1176)



Wood Components (Not to Scale)



E1 | REAR UPRIGHT - W2A02660
(x1) | 1 3/8"x3 3/8"x51 3/4" (36x86x2074)

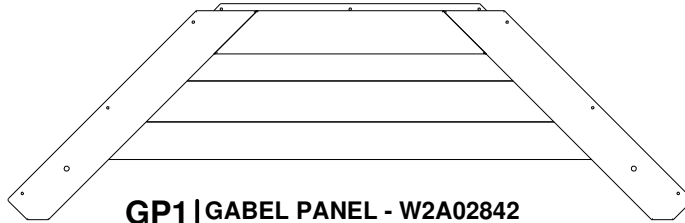

GP1 | GABEL PANEL - W2A02842
(x2) | 1 1/8"x16 3/8"x53 1/2" (27x414x1359)

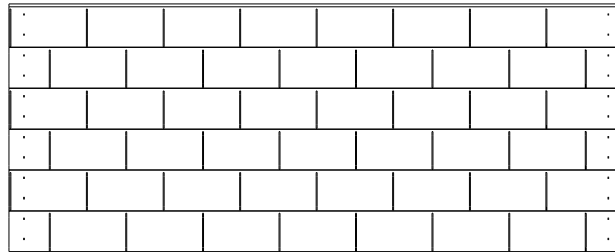

RP1 | ROOF PANEL - W2A02092
(x2) | 1 3/8"x48"x19 3/8" (35x1220x491)

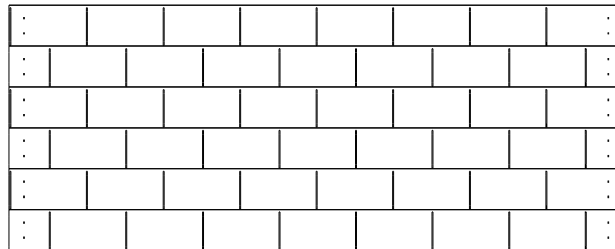

RP2 | ROOF PANEL - W2A02093
(x2) | 1 3/8"x48"x19 1/8" (35x1220x486)



Hardware Components



H100363 | BOLT WH BLK
(x1) | 5/16X6



H100415 | BOLT WH BLK
(x2) | 5/16x3 3/4



H100396 | BOLT WH BLK
(x3) | 5/16x1/2



H100503 | BOLT WH BLK
(x4) | 5/16x3-1/2



H100663 | BOLT WH BLK
(x4) | 5/16x3/4



H100416 | BOLT WH BLK
(x13) | 5/16x3



H100468 | BOLT WH BLK
(x7) | 5/16x1



H100205 | BOLT WH BLK
(x15) | 5/16x2-1/4



H100459 | BOLT WH BLK
(x9) | 5/16x1 1/4



H100457 | BOLT WH BLK
(x50) | 5/16x2

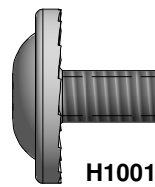

H100115 | BOLT WH
(x15) | 5/16x1/2



H100378 | BOLT WH BLK
(x9) | 5/16x1 3/4

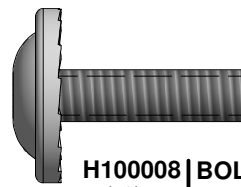

H100008 | BOLT WH
(x9) | 5/16x1



H100407 | BOLT WH BLK
(x2) | 5/16x1 1/2

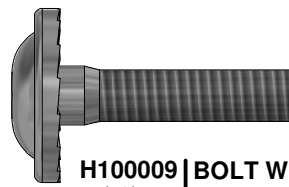

H100009 | BOLT WH
(x9) | 5/16x1 1/4



Hardware Components



H100206 | LAG SCREW WH BLK
(x2) | 5/16x3



H100197 | LAG SCREW WH BLK
(x1) | 5/16x2 1/2



H100458 | LAG SCREW WH BLK
(x28) | 5/16x2



H100471 | LAG SCREW WH BLK
(x30) | 5/16x1 1/2

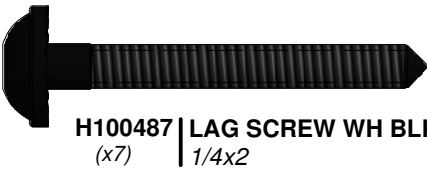

H100487 | LAG SCREW WH BLK
(x7) | 1/4x2



H100180 | SCREW PWH
(x9) | 8x1-1/4



H100797 | SCREW PWH BLK
(x19) | 8x1



H100481 | BOLT HEX BLK
(x4) | 5/16x1 1/4

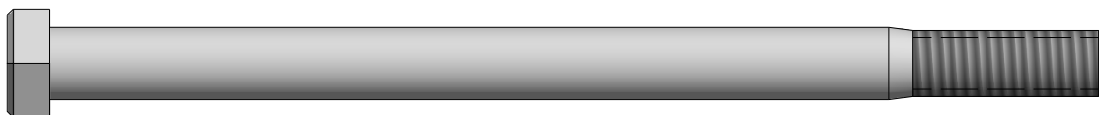

H100654 | BOLT HEX
(x13) | 3/8x5-1/2



H100193 | NUT BARREL
(x2) | WH BLK
5/16x1-1/2



H100192 | NUT BARREL
(x25) | WH BLK
5/16x7/8



H100469 | NUT BARREL
(x8) | WH BLK
5/16x5/8



H100832 | BOLT PTH
(x4) | 1/4x3/4



H100401 | BOLT WH BLK
(x1) | 1/4x1/2



H100785 | SCREW PWH
(x7) | 8x1



H100392 | SCREW PWH BLK
(x2) | 8x3/4



H100831 | NUT BARREL
(x4) | PTH BLK
1/4x3/4



H100399 | NUT BARREL
(x1) | WH BLK
1/4x7/8



H100006 | NUT BARREL
(x9) | WH
5/16x1 1/2

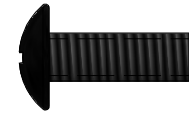

H100489 | BOLT PTH BLK
(x26) | 1/4x3/4



H100486 | BOLT WH BLK
(x2) | 1/4x5/8



H100128 | SCREW PWH
(x9) | 8x5/8



H100408 | SCREW PWH BLK
(x6) | 8x1/2



Hardware Components



H100090 | SCREW PFH
(x33) | 8x2 1/2"



H100111 | SCREW PFH
(x4) | 8x2



H100089 | SCREW PFH
(x18) | 8x1 3/4



H100086 | SCREW PFH
(x229) | 8x1 1/2



H100088 | SCREW PFH
(x70) | 8x1 1/8



H100121 | SCREW PFH
(x7) | 8x3/4

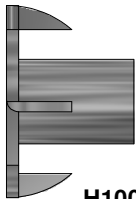

H100073 | T-NUT
(x13) | 3/8

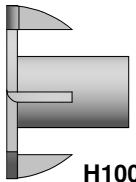

H100074 | T-NUT
(x15) | 5/16

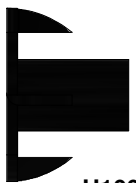

H100379 | T-NUT BLK
(x86) | 5/16



H100398 | T-NUT BLK
(x28) | 1/4



H100821 | SCREW PFH BLK
(x1) | 8x2-3/4



H100201 | SCREW PFH BLK
(x17) | 8x2-1/2



H100391 | SCREW PFH BLK
(x20) | 8x2



H100382 | SCREW PFH BLK
(x15) | 8x1 3/4



H100380 | SCREW PFH BLK
(x12) | 8x1 1/8



H100387 | SCREW PFH BLK
(x45) | 8x1-1/4



H100200 | SCREW PFH BLK
(x84) | 8x1 1/2



H100543 | SCREW PFH SD
(x4) | 8x1/2

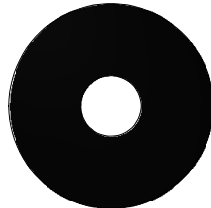

H100478 | WASHER FLAT
(x4) | **BLK**
8x27

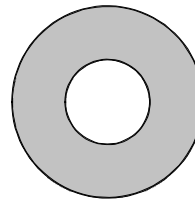

H100102 | WASHER FLAT
(x13) | 11x25

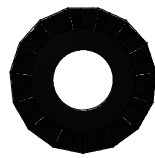

H100198 | WASHER LOCK
(x141) | **EXT BLK**
8x19

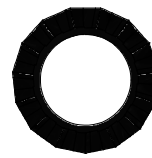

H100199 | WASHER LOCK
(x22) | **EXT BLK**
12x19

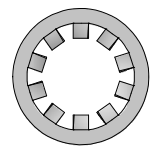

H100107 | WASHER LOCK
(x13) | **INT**
10x18



H100473 | WASHER LOCK
(x26) | **INT BLK**
8x15



H100477 | WASHER SPLIT
(x4) | **BLK**
5/16



H100405 | WASHER LOCK
(x7) | **EXT BLK**
6x15



Accessory Components (Not to Scale)

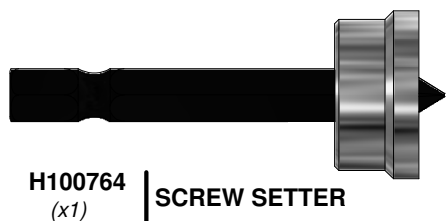

H100764 | SCREW SETTER
(x1)

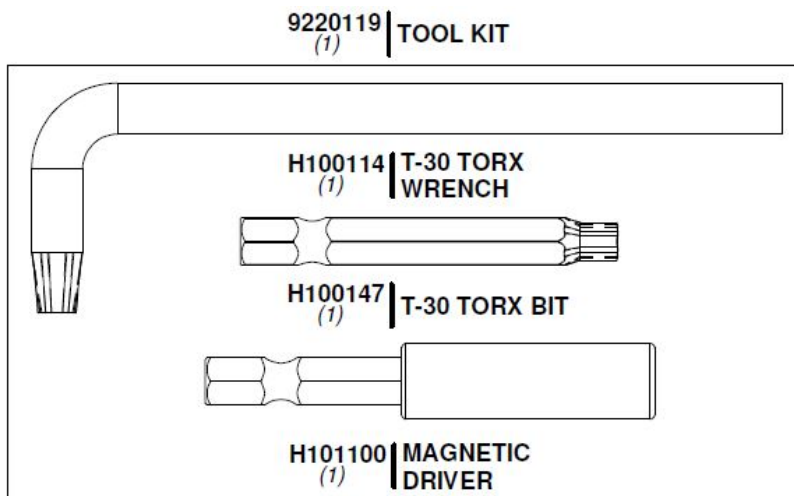

9220119 | TOOL KIT
(1)

H100114 | T-30 TORX WRENCH
(1)

H100147 | T-30 TORX BIT
(1)

H101100 | MAGNETIC DRIVER
(1)

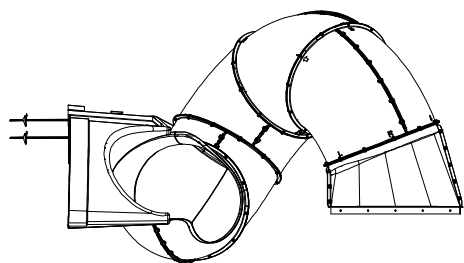

9198036 | TUBE SLIDE
(x1)

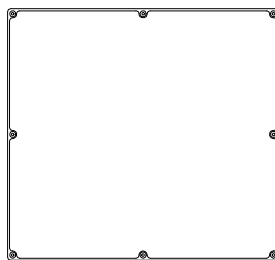

A6P00324 | CHALK BOARD LARGE
(x1)



A6P00487 | SLIDE SUPPORT TUBE
(x4)

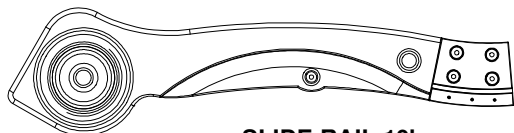

A6P00484 | SLIDE RAIL 10' BOTTOM RIGHT GREEN
(x1)

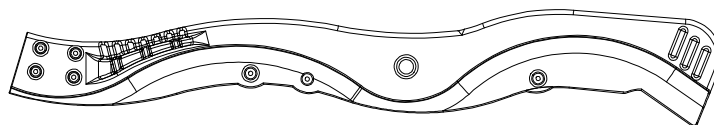

A6P00486 | SLIDE RAIL 10' TOP RIGHT GREEN
(x1)

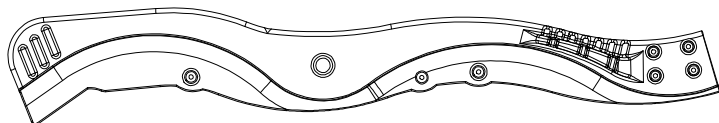

A6P00485 | SLIDE RAIL 10' TOP LEFT GREEN
(x1)

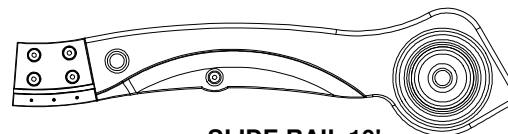

A6P00483 | SLIDE RAIL 10' BOTTOM LEFT GREEN
(x1)

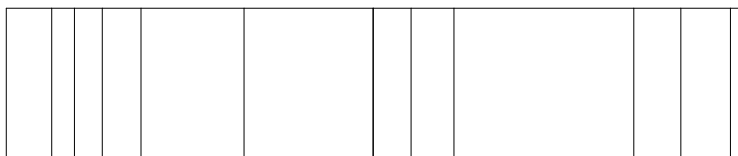

A6P00385 | SLIDE BED 10' DARK GREEN
(x1)



Accessory Components (Not to Scale)

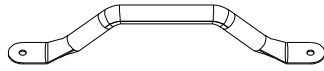

A100118 | **HAND GRIP**
(x2) | **METAL GREEN**
381 c/c

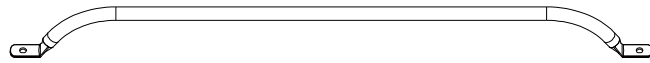

A100134 | **HAND GRIP**
(x2) | **GREEN 816 C/C**



A100164 | **BYD ID TAG**
(x1) | **(LARGE) AGES**
3-10



A100178 | **AUGER GROUND**
(x6) | **STAKE**



A100314 | **"A" REVISION**
(x1) | **TAG**

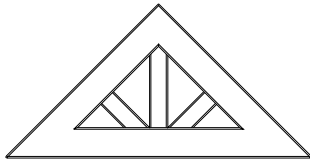

A100322 | **PLASTIC**
(x2) | **SUNBURST**

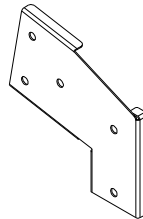

A100325 | **SWING BEAM**
(x1) | **EXTENSION**
BRACKET-LEFT

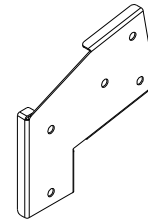

A100326 | **SWING BEAM**
(x1) | **EXTENSION**
BRACKET-RIGHT

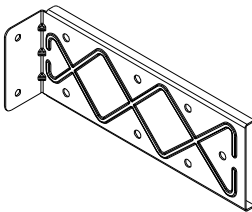

A4M00993 | **EXTENDED**
(x2) | **SWING BEAM**
BRACKET



A4M00710 | **L BRACKET**
(x1) | **BLACK 32x51**

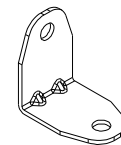

A4M01047 | **L BRACKET**
(x2) | **2.5x38x55x55**

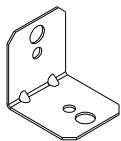

A4M01110 | **90° L-BRACKET -**
(x2) | **BLK**



A4M01117 | **53" SLIDE**
(x1) | **BRACE (RIGHT)**



A4M01118 | **53" SLIDE**
(x1) | **BRACE (LEFT)**

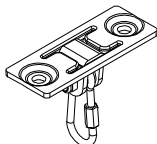

A4M00505 | **SWING HANGER**
(x6)

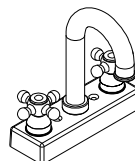

A6P00024 | **FAUCET KIT**
(x1)

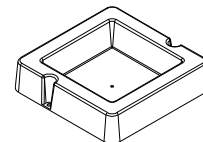

A6P00032 | **SURFACE**
(x1) | **MOUNT BASIN**



Accessory Components (Not to Scale)



A4M01415 | 26" WEB SWING (EU)
(x1)



A6P00037 | GREEN HC ROCK
(x12) #2

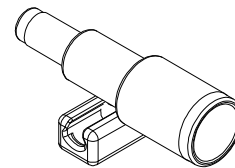

A6P00096 | TELESCOPE
(x1)

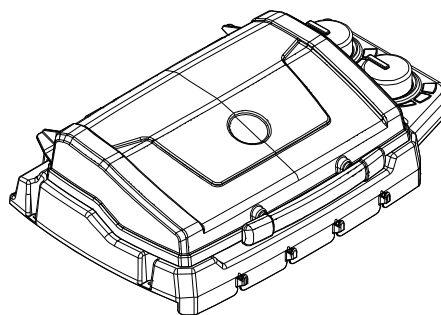

A6P00282 | BBQ GRILL
(x1)

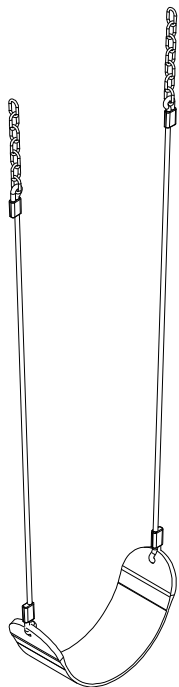

A6P00397 | SWING
(x2)



141154 | GRILL FOOD SET
(x1)



BE SURE TO WASH ALL PLASTIC TOYS BEFORE USE.

PRE-ASSEMBLY STEP 1 - SORTING PARTS

It is critical for ease of assembly that you take the time to sort and organize the wood and hardware.

WOOD PARTS:

- Organize wood parts by the three-digit, alpha-numeric number stamped on each board (ex. P01).
- If there are multiple boards with the same stamped number, stack those pieces together.
- Stamps can be found on the flat surface of the boards or on the end of the boards.
- Allow yourself plenty of room - the wood pieces can take up a significant amount of space.

NOTE: CARTONS ARE NOT ORGANIZED BY BOARD NUMBER.

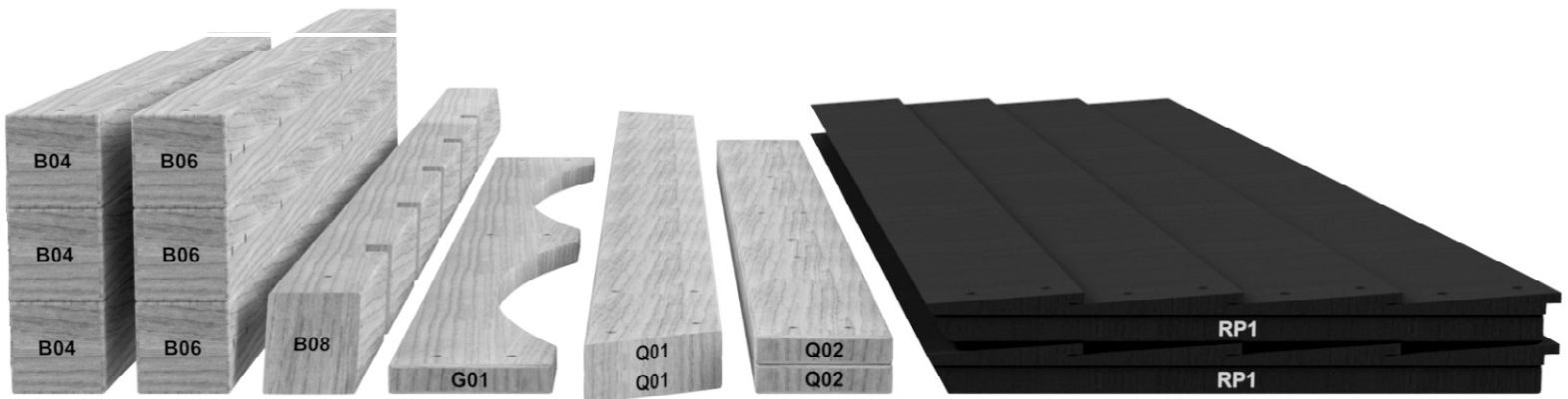

HARDWARE PARTS:

- We recommend that you have a separate table to organize the hardware.
- Hardware bags are printed with a seven-digit, alpha-numeric part number.
- You can organize your hardware by part number or group by hardware type (i.e. bolts, nuts, etc.).
- During assembly you only need to reference the last four digits of the number.

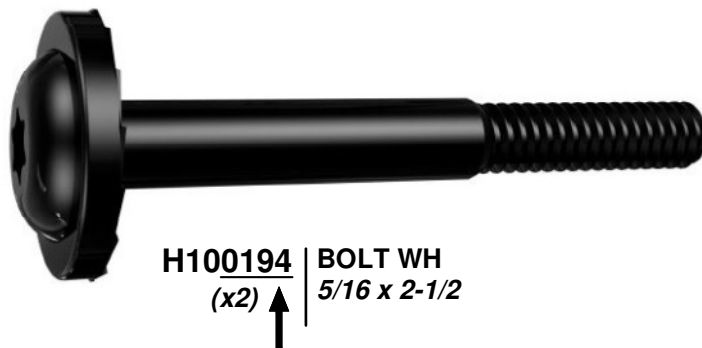

PRE-ASSEMBLY STEP 2 - TOOLS REQUIRED



**Cordless Drill or
Electric Drill**



**Drill Attachments:
Phillips Head**



**1/8", 3/16", 3/8" & 7/16"
Drill Bits**



Phillips Screw Driver



Open End Wrenches 1/2" & 9/16"



**3/8" Drive Ratchet, 1/2" &
9/16" STD Sockets 1/2" & 9/16" Deep
Sockets**



Claw Hammer



Rubber Mallet - Optional



Tape Measure

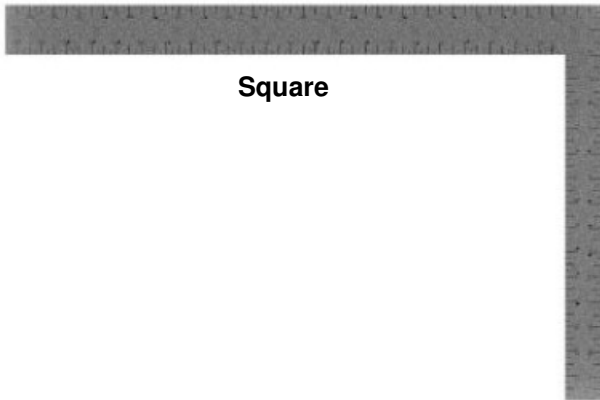

Square



Level 24"

PRE-ASSEMBLY STEP 3 - CHOOSE YOUR ASSEMBLY METHOD

There are several types of assembly instructions available to you.

1. Printed Assembly Manual included with your set
2. BILT APP - 3D interactive instructions
3. Combination of the Printed Manual and BILT APP (Note: Step numbers can differ between the two methods)

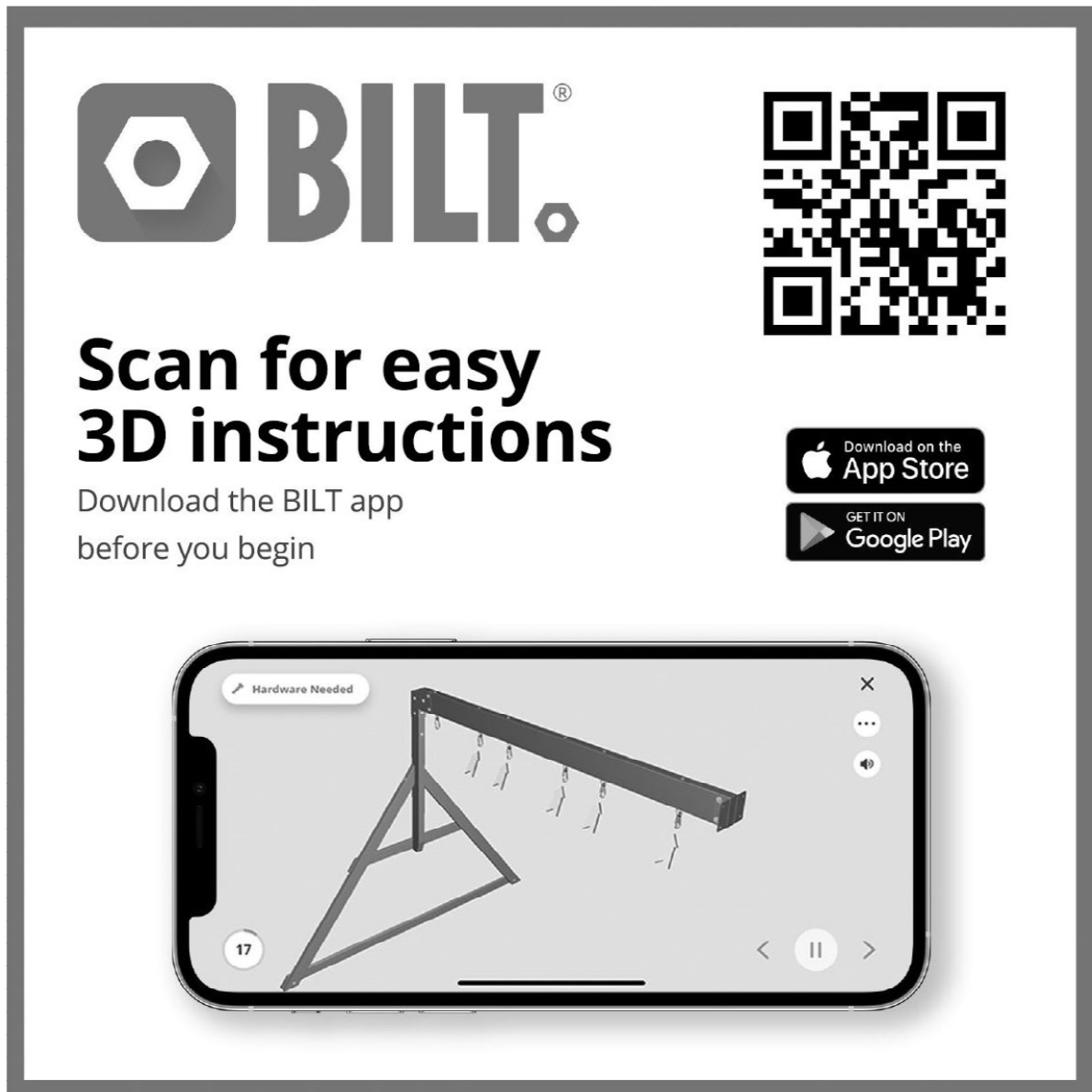

The advertisement features the BILT logo on the left, a QR code on the right, and a central text area. Below the text are two app store download buttons and a smartphone mockup showing the app's interface. The smartphone screen displays a 3D assembly diagram of a metal frame with a horizontal beam and hanging components. The interface includes a 'Hardware Needed' label, a step number '17', and navigation controls like back, pause, and forward arrows.

BILT.®



Scan for easy 3D instructions

Download the BILT app
before you begin

Download on the
App Store

GET IT ON
Google Play

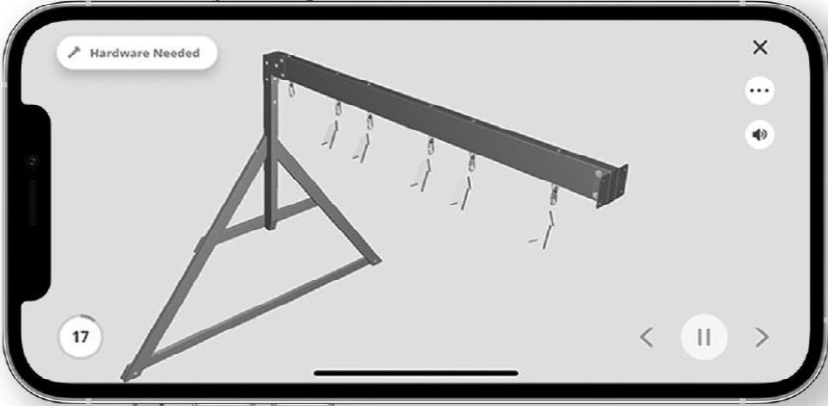

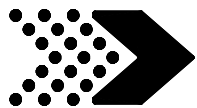

LADDER

STEP 1

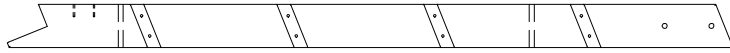

E15 | LEFT UPRIGHT - W4L13322
(x1) | 1 3/8"x3 3/8"x56 3/4" (36x86x1441)

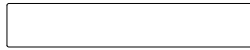

H16 | LADDER RUNG - W4L13324
(x4) | 1"x3 3/8"x19 1/4" (24x86x489)

H100201 | SCREW PFH BLK
(x8) | 8x2-1/2

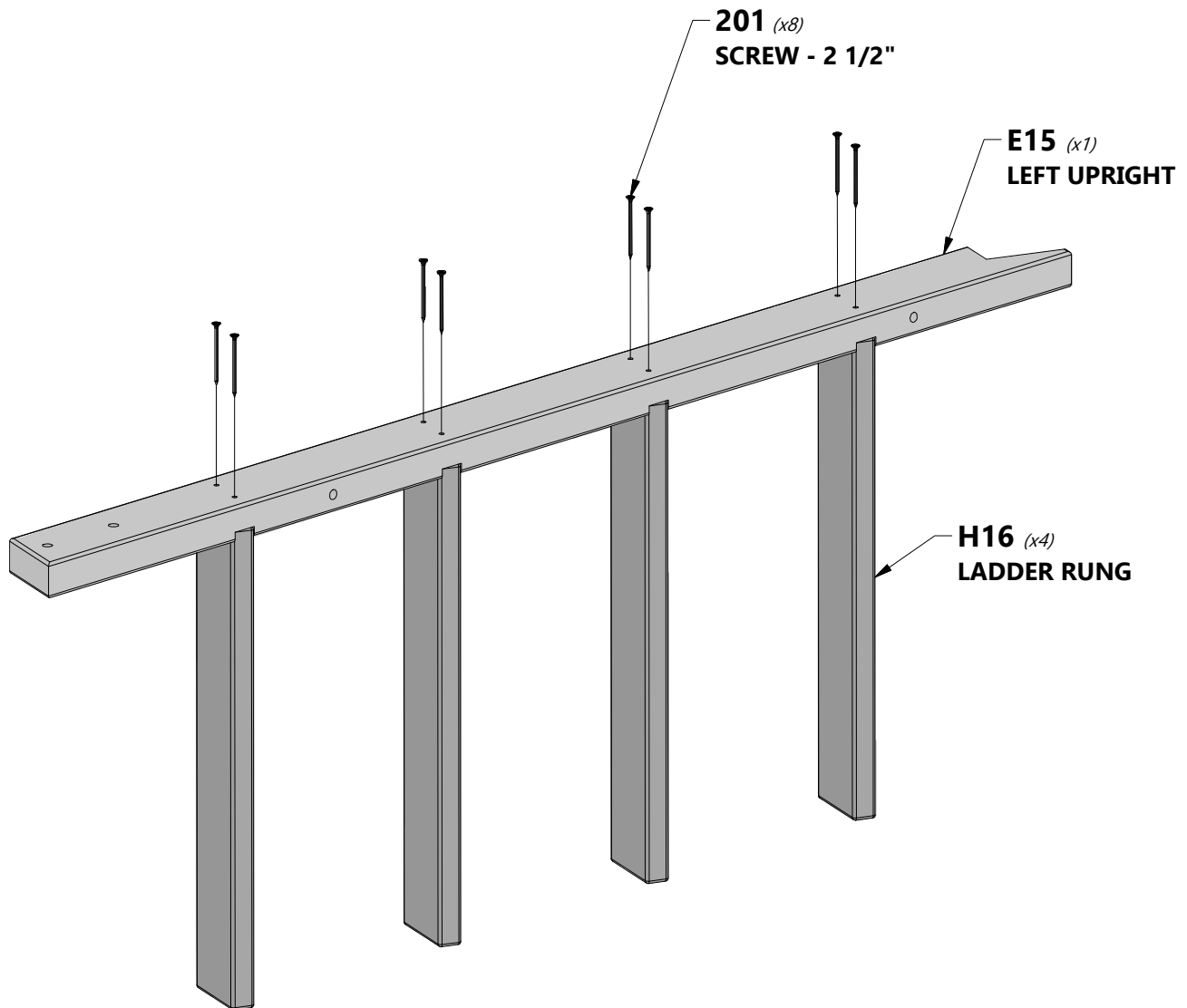

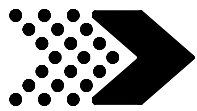

LADDER

STEP 2

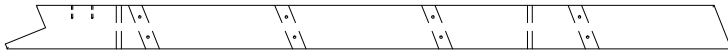

E16 | MIDDLE UPRIGHT - W4L13323
(x1) | 1 3/8"x3 3/8"x56 3/4" (36x86x1441)



H100201 | SCREW PFH BLK
(x8) | 8x2-1/2

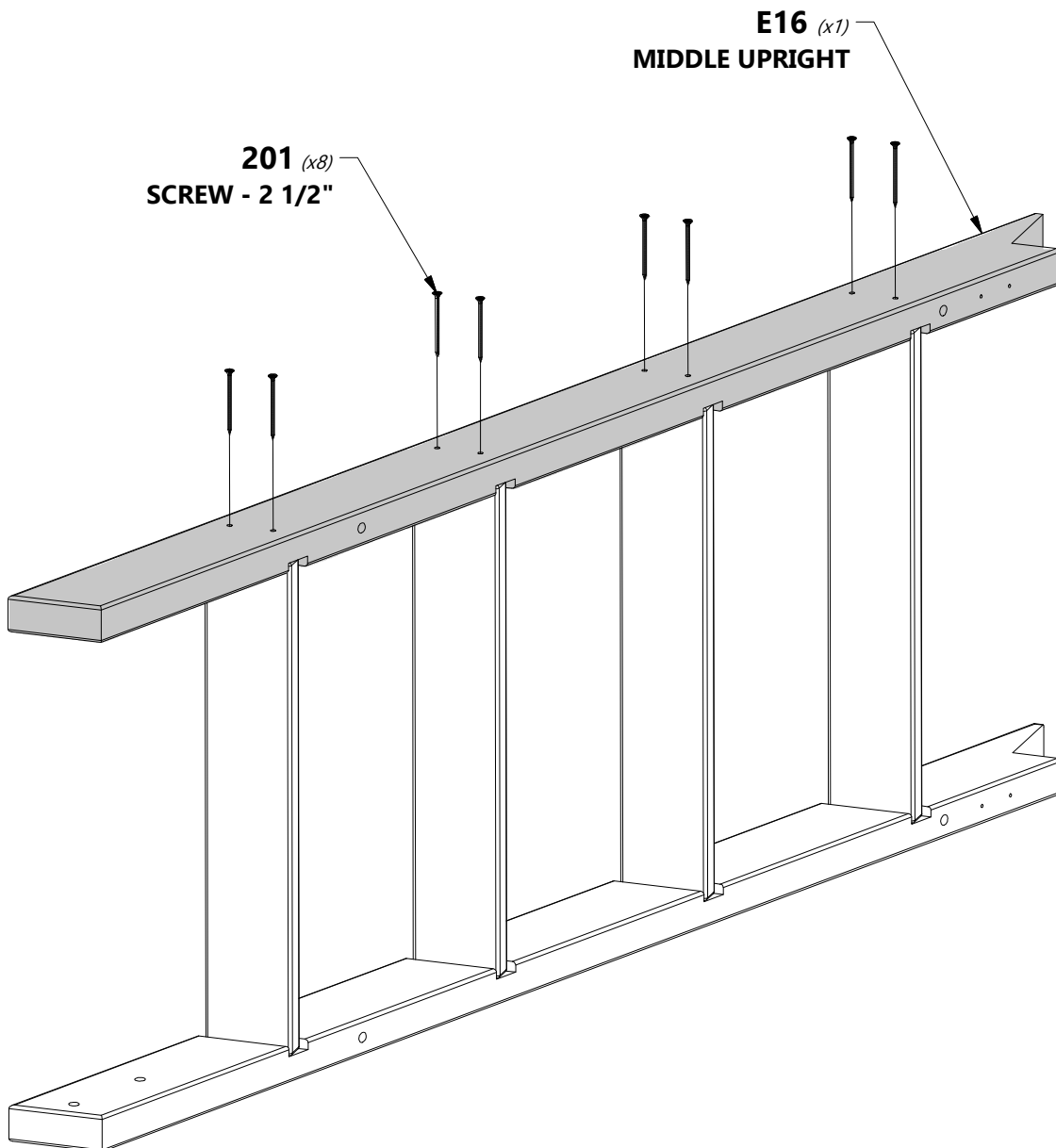

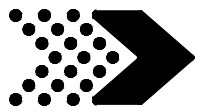

LADDER

STEP 3



M12 | **REAR SUPPORT - W4L13325**
(x1) | 5/8"x3 3/8"x21 1/4" (16x86x541)



H100200 | **SCREW PFH BLK**
(x4) | 8x1 1/2

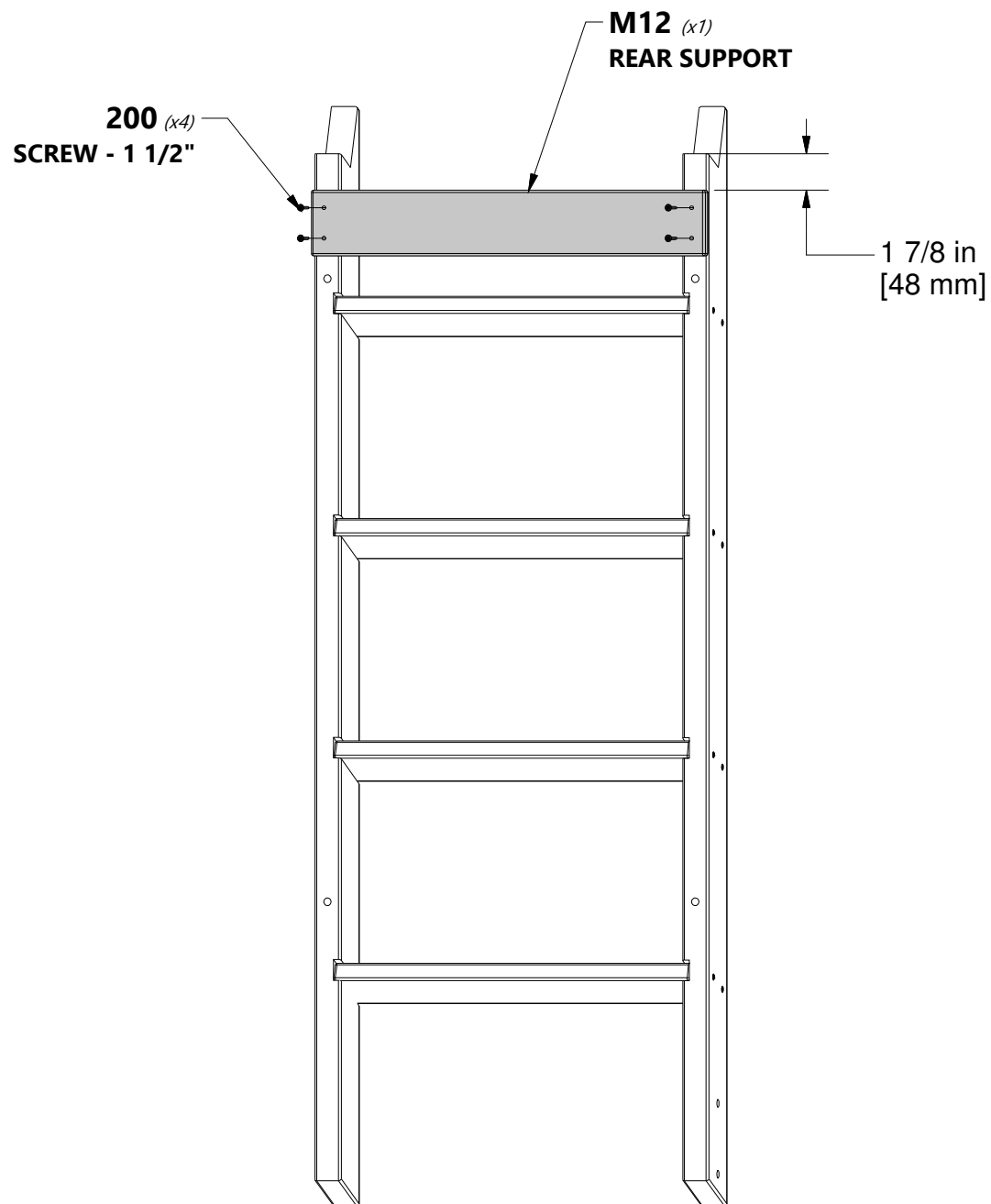

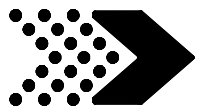

LADDER

STEP 4

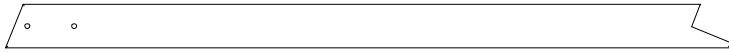

E17 | **RIGHT UPRIGHT - W4L13327**
(x1) | 1 3/8"x3 3/8"x56 3/4" (36x86x1441)

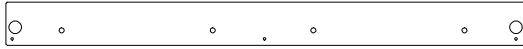

H1 | **ATTACHMENT BOARD - W4L13326**
(x1) | 1"x3 3/8"x40 1/2" (24x86x1030)



H100391 | **SCREW PFH BLK**
(x3) | 8x2



H100379 | **T-NUT BLK**
(x4) | 5/16



ASSEMBLY NOTE:

ADD T-NUTS AS SHOWN
PRIOR TO INSTALLING THE
BOARDS.

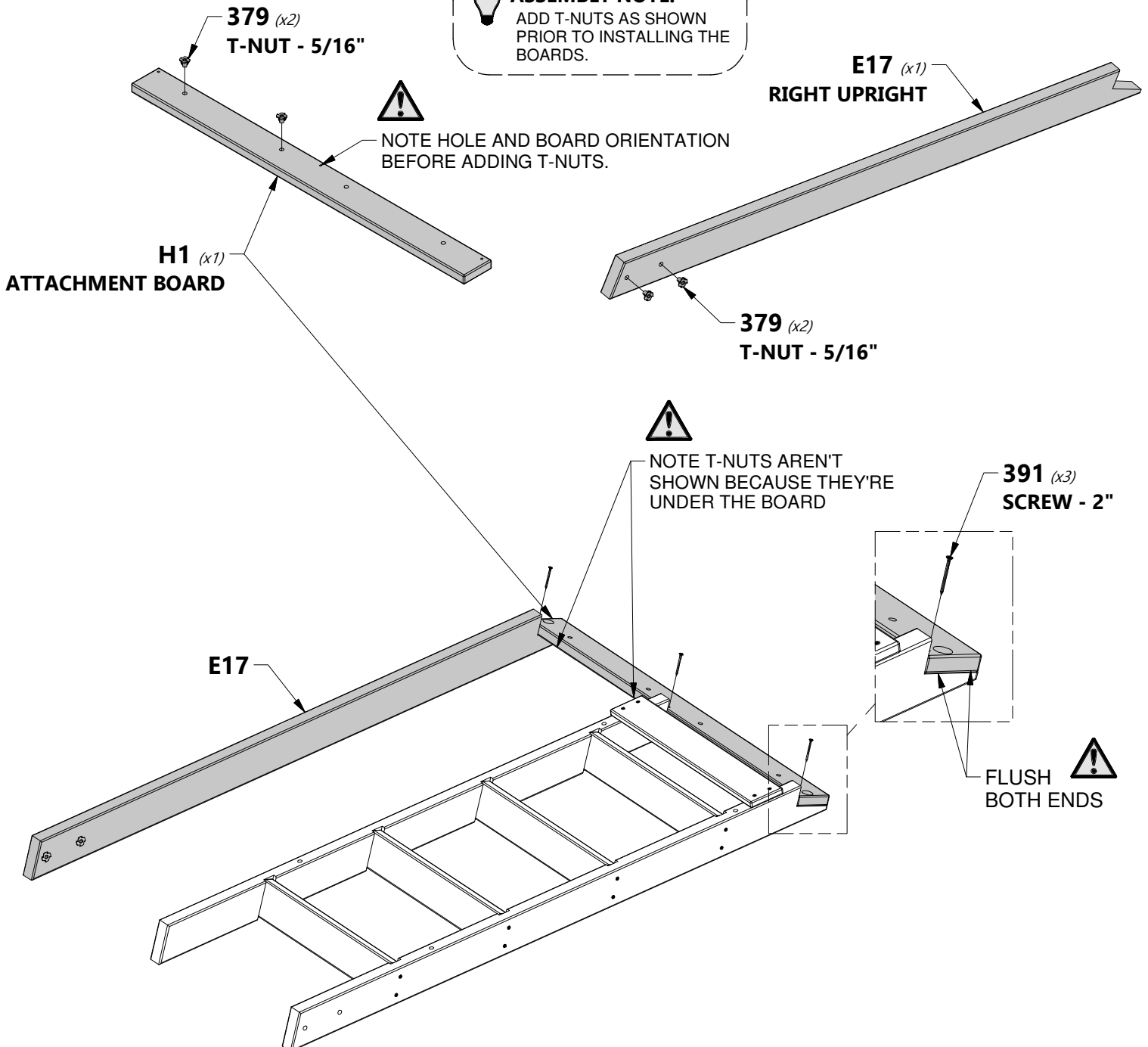

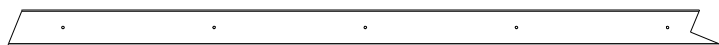

H2 | UPRIGHT - W4L13338
(x2) | 1"x2 3/4"x55 7/8" (24x70x1419)



H100391 | SCREW PFH BLK
(x10) | 8x2

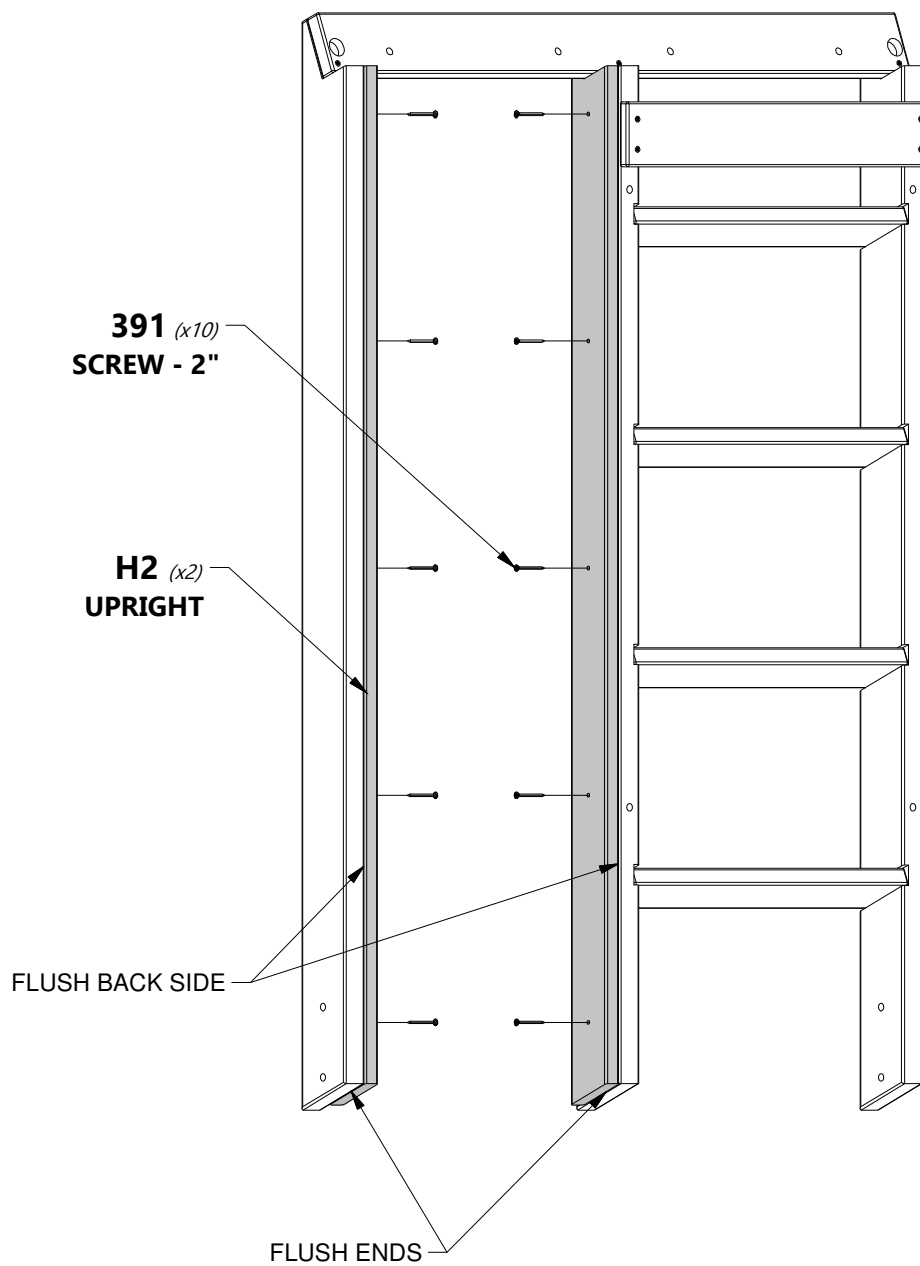

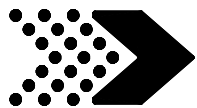

LADDER

STEP 6

N4 | ROCK BOARD - W4L13331
(x1) | 5/8"x1 3/4"x17 7/8" (16x46x453)

M13 | ROCK BOARD - W4L13328
(x8) | 5/8"x3 3/8"x17 7/8" (16x86x453)

H100398 | T-NUT BLK
(x24) | 1/4"

M14 | ROCK BOARD - W4L13329
(x4) | 5/8"x3 3/8"x17 7/8" (16x86x453)

M15 | ROCK BOARD - W4L13330
(x4) | 5/8"x3 3/8"x17 7/8" (16x86x453)

H100200 | SCREW PFH BLK
(x66) | 8x1 1/2"

RECOMMENDED BOARD PATTERN

PREPARATION: INSTALL T-NUTS

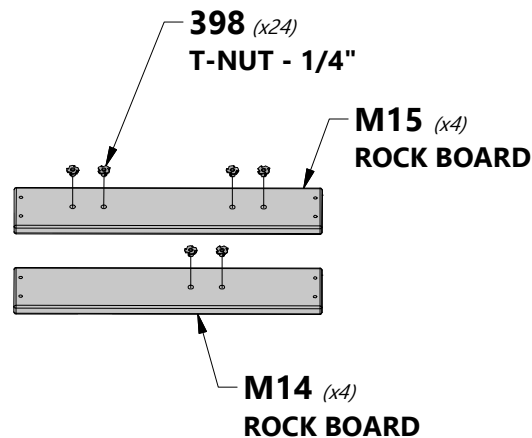
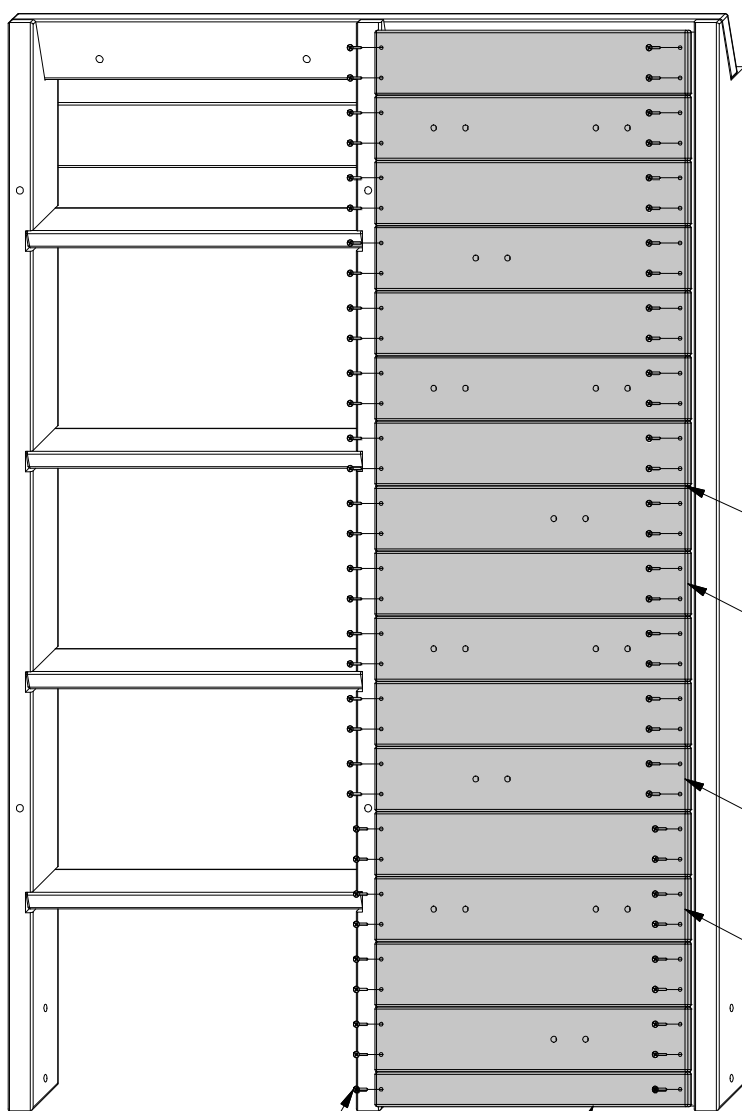

NOTE EVENLY SPACE ALL GAPS.

M13 (x8)
ROCK BOARD

M14 (x4)
ROCK BOARD

M15 (x4)
ROCK BOARD

200 (x66)
SCREW - 1 1/2"

N4 (x1)
ROCK BOARD



ASSEMBLY TIP:

IT CAN HELP TO SET ALL THE BOARDS IN PLACE TO MAKE SURE THEY MATCH THE DIAGRAM PRIOR TO MOUNTING THEM WITH THE PROVIDED SCREWS.

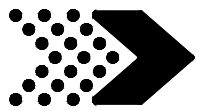

LADDER

STEP 7



N5 | **ROCKWALL CLEAT - W4L13332**
(x1) | 5/8"x2 3/8"x53 7/8" (16x60x1370)



H100380 | **SCREW PFH BLK**
(x11) | 8x1 1/8

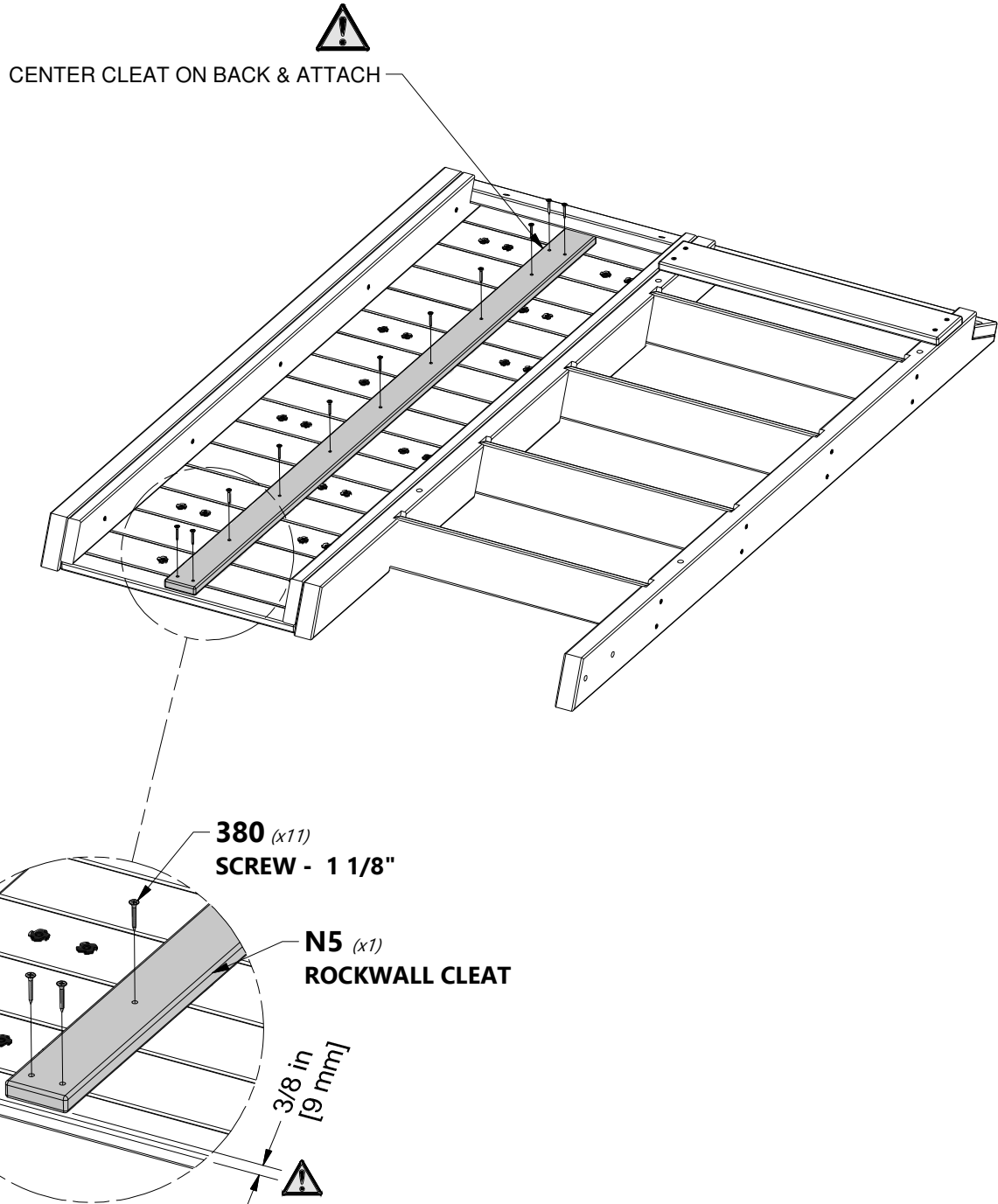

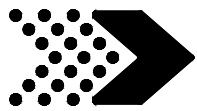

LADDER

STEP 8

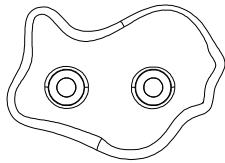

A6P00037 | GREEN HC ROCK #2
(x12)

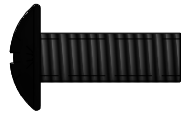

H100489 | BOLT PTH BLK
(x24) | 1/4x3/4

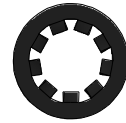

H100473 | WASHER LOCK INT BLK
(x24) | 8x15

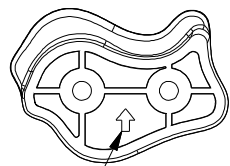

ARROW FACES
UPWARD

489 (x24)
BOLT - 3/4"

473 (x24)
WASHER - 8x15"

037 (x12)
GREEN HC ROCK #2

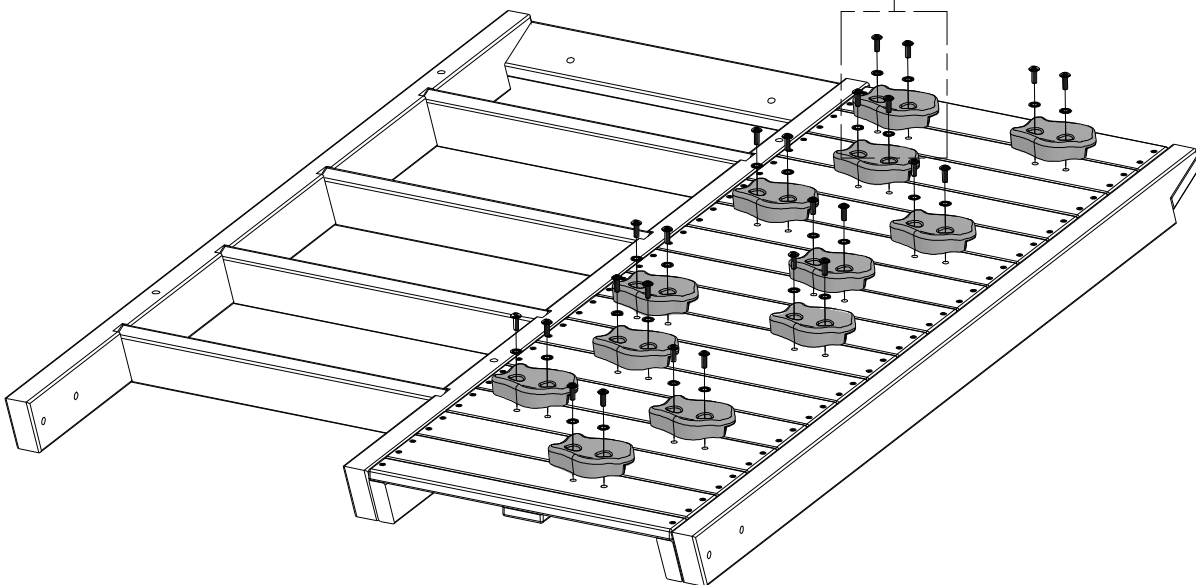
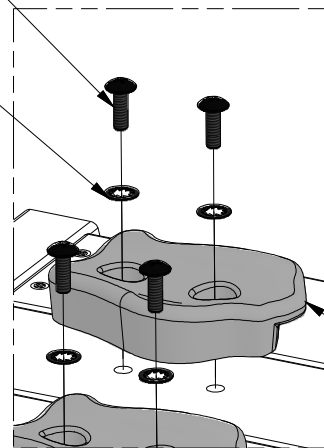

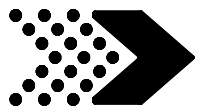

LADDER

STEP 9

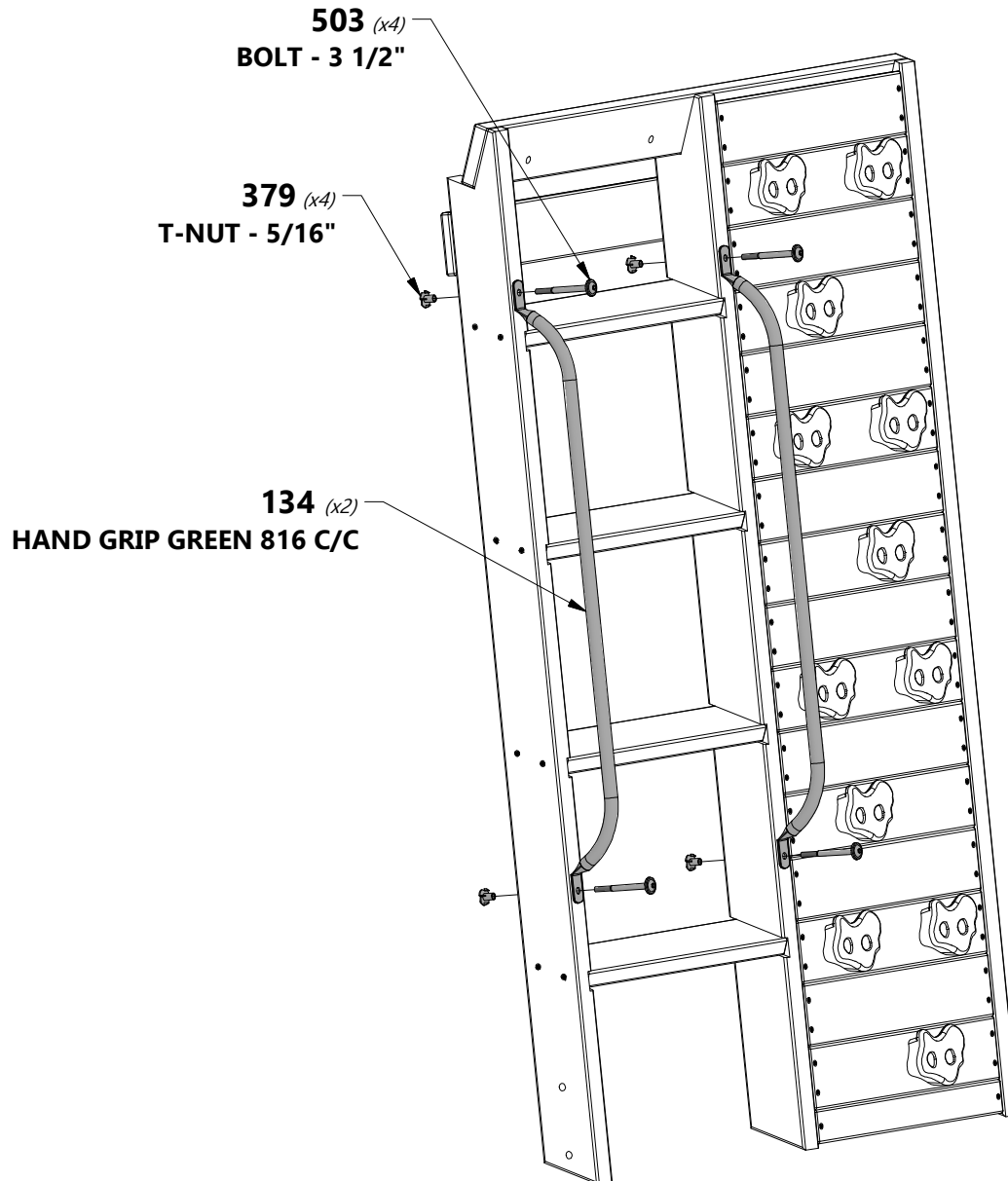
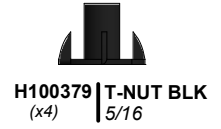
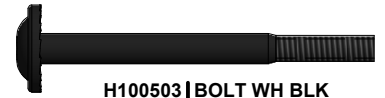
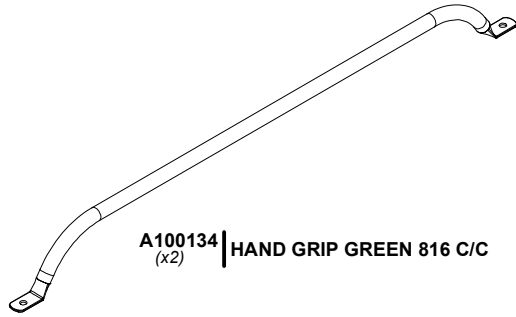



SLIDE ASSEMBLY

STEP 1



A6P00385 | SLIDE BED 10' DARK GREEN
(x1)



M70 | SLIDE BED SUPPORT - W100935
(x1) | 5/8"x3 3/8"x19 7/8" (16x86x505)



H100115 | BOLT WH
(x3) | 5/16x1/2



H100074 | T-NUT
(x3) | 5/16



NOTE:

TAKE NOTE OF SLIDE BED SURFACE FINISH, THE DULL SIDE WILL BE TOWARDS THE GROUND. PLACE SLIDE BRACE CENTERED ON THE BOTTOM (DULL SIDE) AND 1/2" FROM THE EDGE. USE **M70** BOARD AS A TEMPLATE FOR DRILLING BOTTOM HOLE PATTERN IN SLIDE BED. USE A 5/16" DRILL BIT.



TIP:

PRE-BENDING THE ENDS WILL EASE ASSEMBLY. PLACING THE SLIDE BED OUT IN THE SUN MAKES IT EASIER TO BEND.

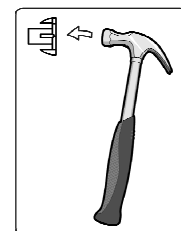

TOP

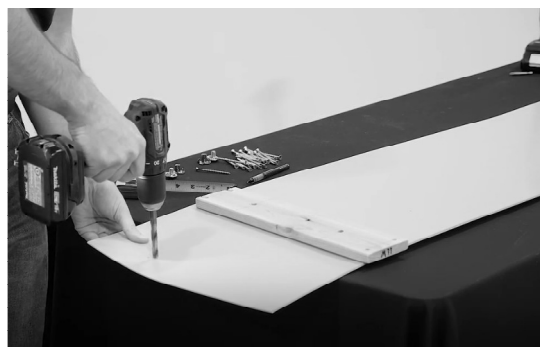
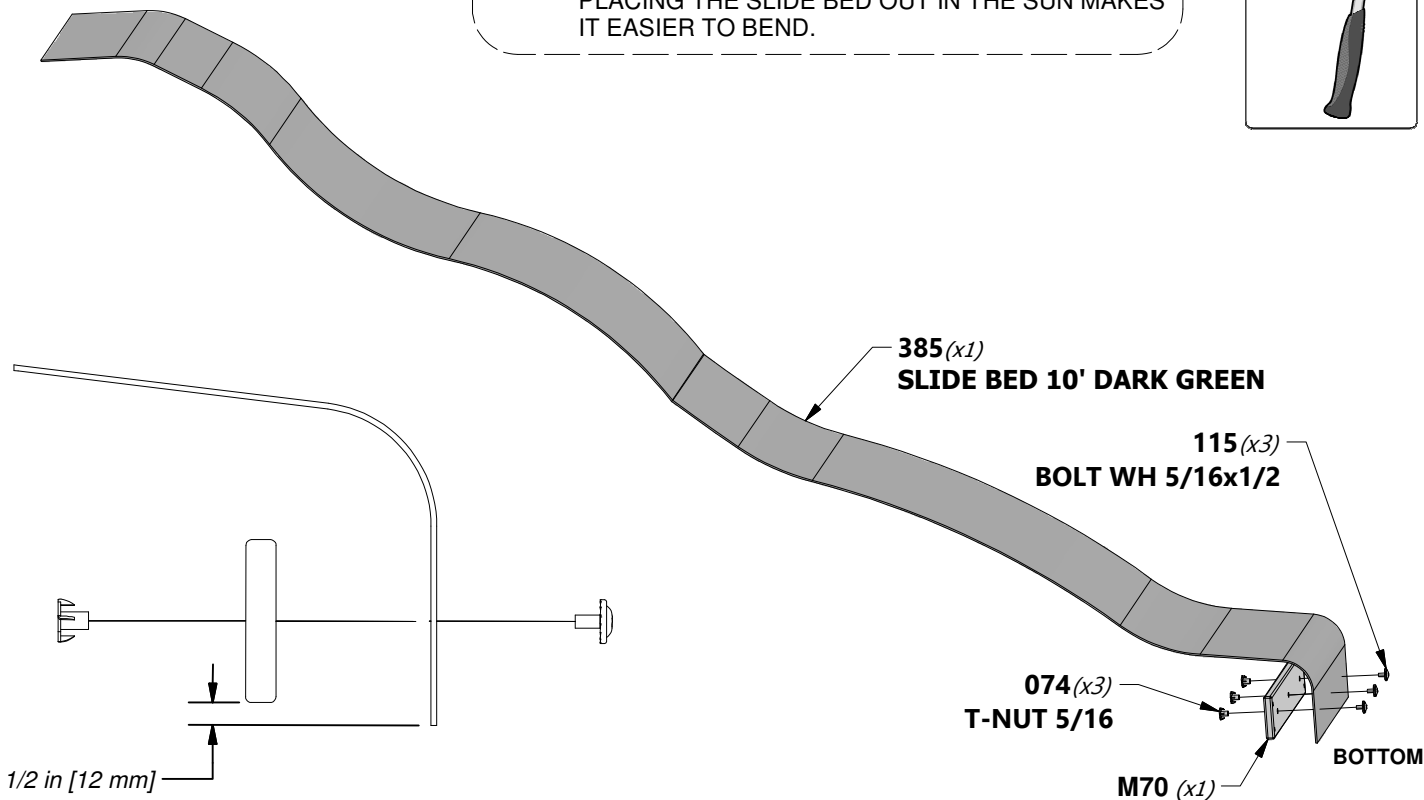



SLIDE ASSEMBLY

STEP 2



A6P00484 | SLIDE RAIL 10' BOTTOM RIGHT GREEN
(x1)

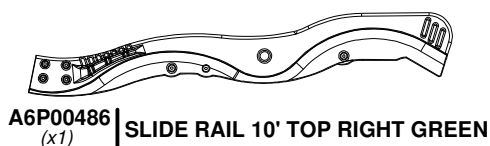

A6P00486 | SLIDE RAIL 10' TOP RIGHT GREEN
(x1)

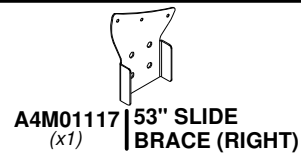

A4M01117 | 53" SLIDE BRACE (RIGHT)
(x1)

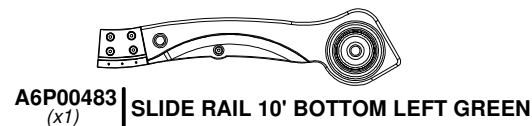

A6P00483 | SLIDE RAIL 10' BOTTOM LEFT GREEN
(x1)

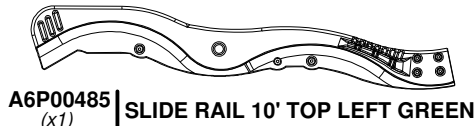

A6P00485 | SLIDE RAIL 10' TOP LEFT GREEN
(x1)

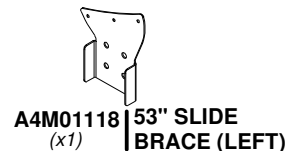

A4M01118 | 53" SLIDE BRACE (LEFT)
(x1)



H100006 | NUT BARREL WH
(x8) | 5/16x1 1/2



H100115 | BOLT WH
(x8) | 5/16x1/2



H100121 | SCREW PFH
(x6) | 8x3/4



NOTE:

BUILD 2 SIDE RAILS, MAKING A LEFT AND RIGHT ASSEMBLY.

486 (x1)
SLIDE RAIL 10' TOP RIGHT GREEN

484 (x1)
SLIDE RAIL 10' BOTTOM RIGHT GREEN

121 (x3)
SCREW - 8x3/4"

006 (x4)
NUT BARREL - 1 1/2"

117 (x1)
53" SLIDE BRACE (RIGHT)

115 (x4)
BOLT - 1/2"

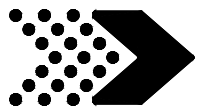

A6P00487 | SLIDE TUBE SUPPORT
 (x4)

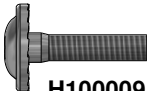
H100009 | BOLT WH
 (x4) | 5/16x1 1/4

**NOTE:**

INSERT THE (4) SLIDE SUPPORT TUBES INTO THEIR RESPECTIVE PILOT LOCATIONS (FIGURE 1).

PLACE (1) SLIDE RAIL ASSEMBLY ON A FLAT SURFACE AND BEGIN INSERTING SLIDE BED AT THE BOTTOM OF THE SLIDE RAIL (FIGURE 2). HAVE A HELPER BEND THE SLIDE BED TOWARDS THE TOP OF THE SLIDE AND INSERT THE BED INTO THE SLIDE CAVITY. MAKE SURE SLIDE BED IS INSERTED WITHIN 1/8" (3mm) OF GROOVE BOTTOM.

**TIP:**

A HELPER IS RECOMMENDED FOR THESE FOLLOWING STEPS.

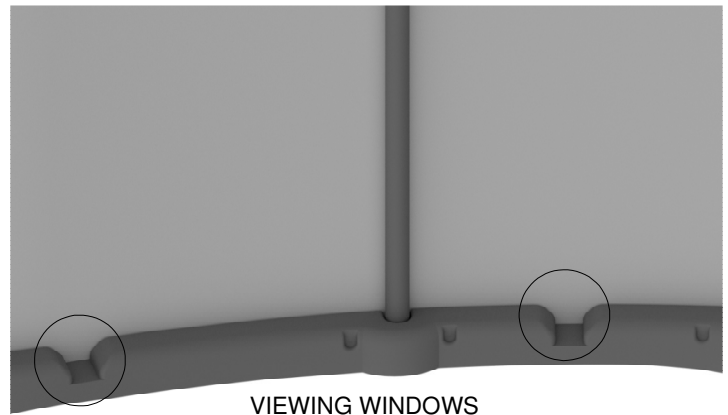
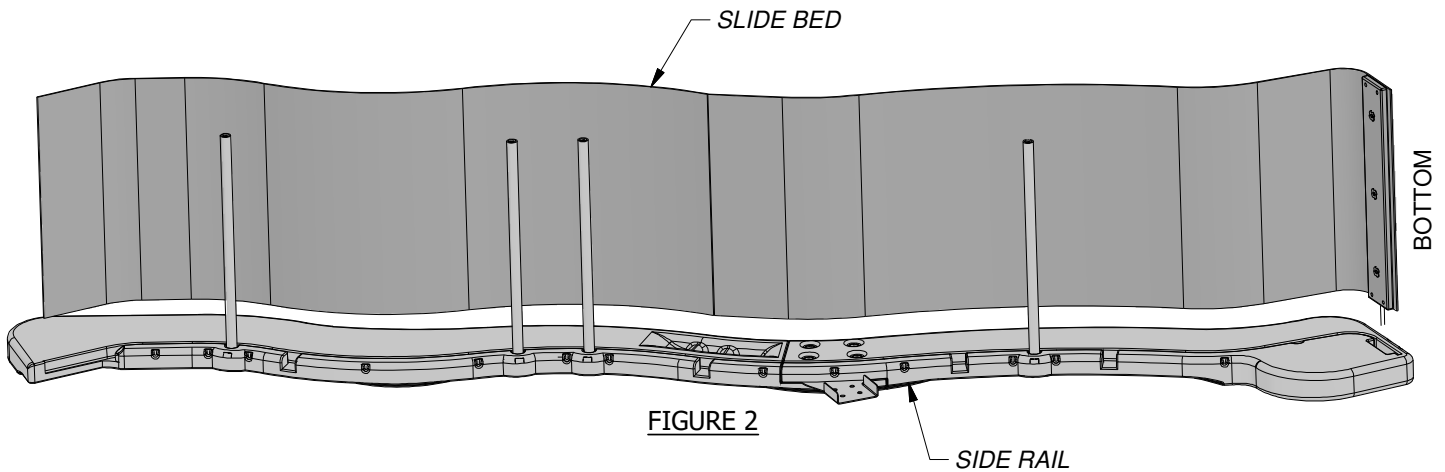
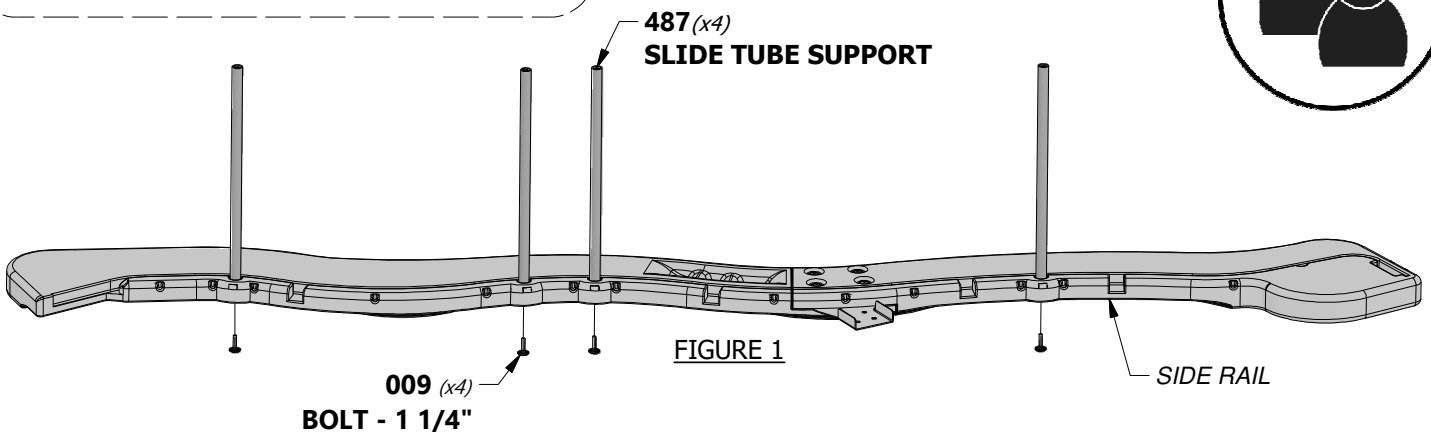

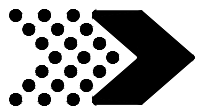

NOTE:

PLACE SECOND SLIDE RAIL ASSEMBLY OVER THE TOP OF THE SLIDE BED AND SLIDE SUPPORT TUBES. INSERT THE SLIDE BED AND SLIDE SUPPORT TUBES INTO THE SLIDE CAVITY. MAKE SURE SLIDE BED IS INSERTED WITHIN 1/8" (3mm) OF GROOVE BOTTOM.



FAILURE TO INSERT SLIDE BED PROPERLY MAY RESULT IN INJURY OR AMPUTATION. EXPOSED SLIDE EDGES CAN BE SHARP AND BECOME A LACERATION HAZARD IF THE SLIDE IS NOT PROPERLY ASSEMBLED.

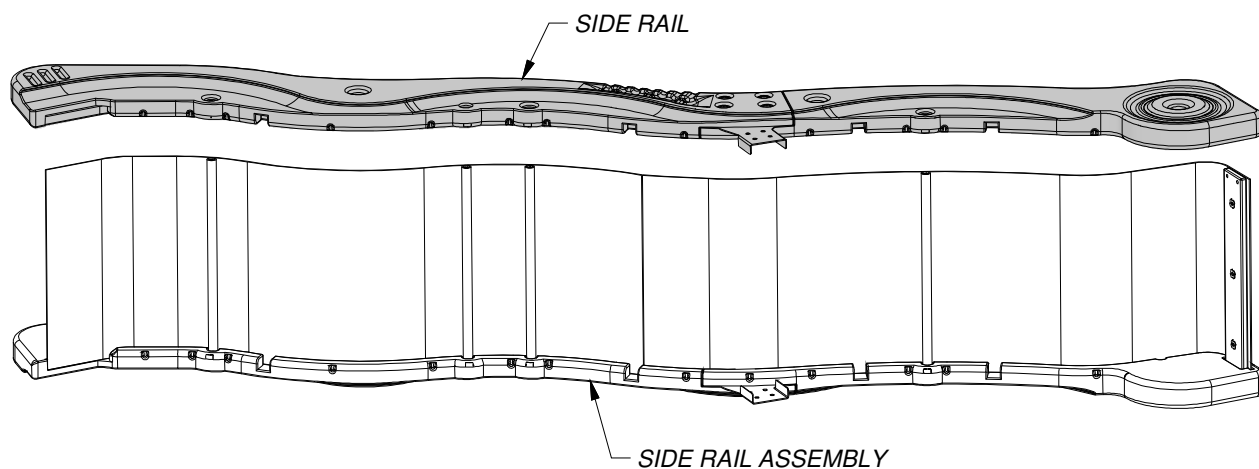

TIP:

USE A RUBBER Mallet TO FULLY SEAT THE SLIDE BED INTO THE SLIDE CAVITY.

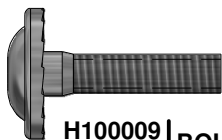

H100009 | BOLT WH 5/16x1 1/4
(x4)



NOTE:
USE 1 1/4" BOLTS TO FASTEN EACH
SIDE OF THE SLIDE SUPPORT TUBES.



TIP:
HAVING A HELPER HOLD THE SLIDE
ASSEMBLY TOGETHER WHILE YOU FASTEN
WILL MAKE IT EASIER TO ASSEMBLE.

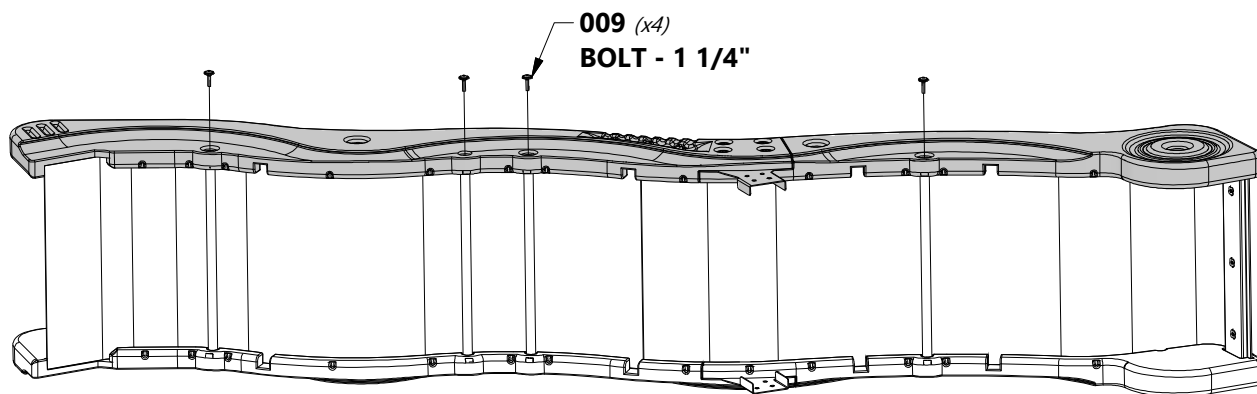



H100090 | SCREW PFH
(x30) | 8x2 1/2"



NOTE:

USING AN 1/8" DRILL BIT, DRILL PILOT HOLES IN EACH INDENTATION ALONG EACH SIDE RAIL. THERE SHOULD BE 15 INDENTATIONS ON EACH RAIL. BE SURE TO DRILL THROUGH THE SLIDE RAIL AND THE SLIDE BED. THEN SECURE WITH THE PROVIDED HARDWARE.

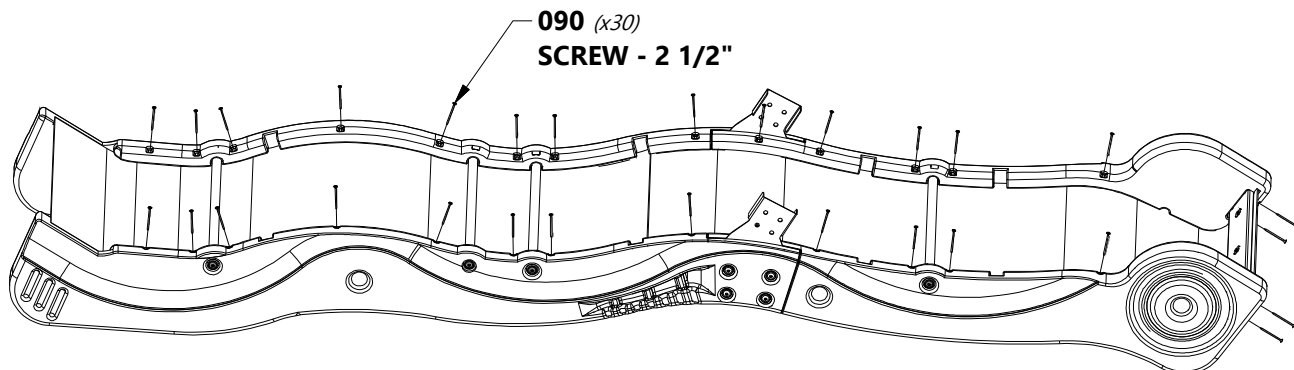



SLIDE ASSEMBLY

STEP 7

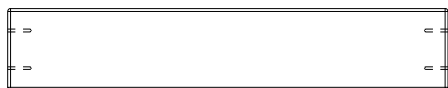

H80 | SLIDE BRACE WIDE - W4L15715
(x1) | 1"x3 3/8"x18 3/8" (24x86x466)



H83 | SLIDE BRACE - W4L13333
(x2) | 1"x3 3/8"x20 1/8" (24x86x512)

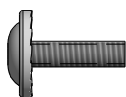

H100008 | BOLT WH
(x8) | 5/16x1



H100074 | T-NUT
(x8) | 5/16



H100111 | SCREW PFH
(x4) | 8x2

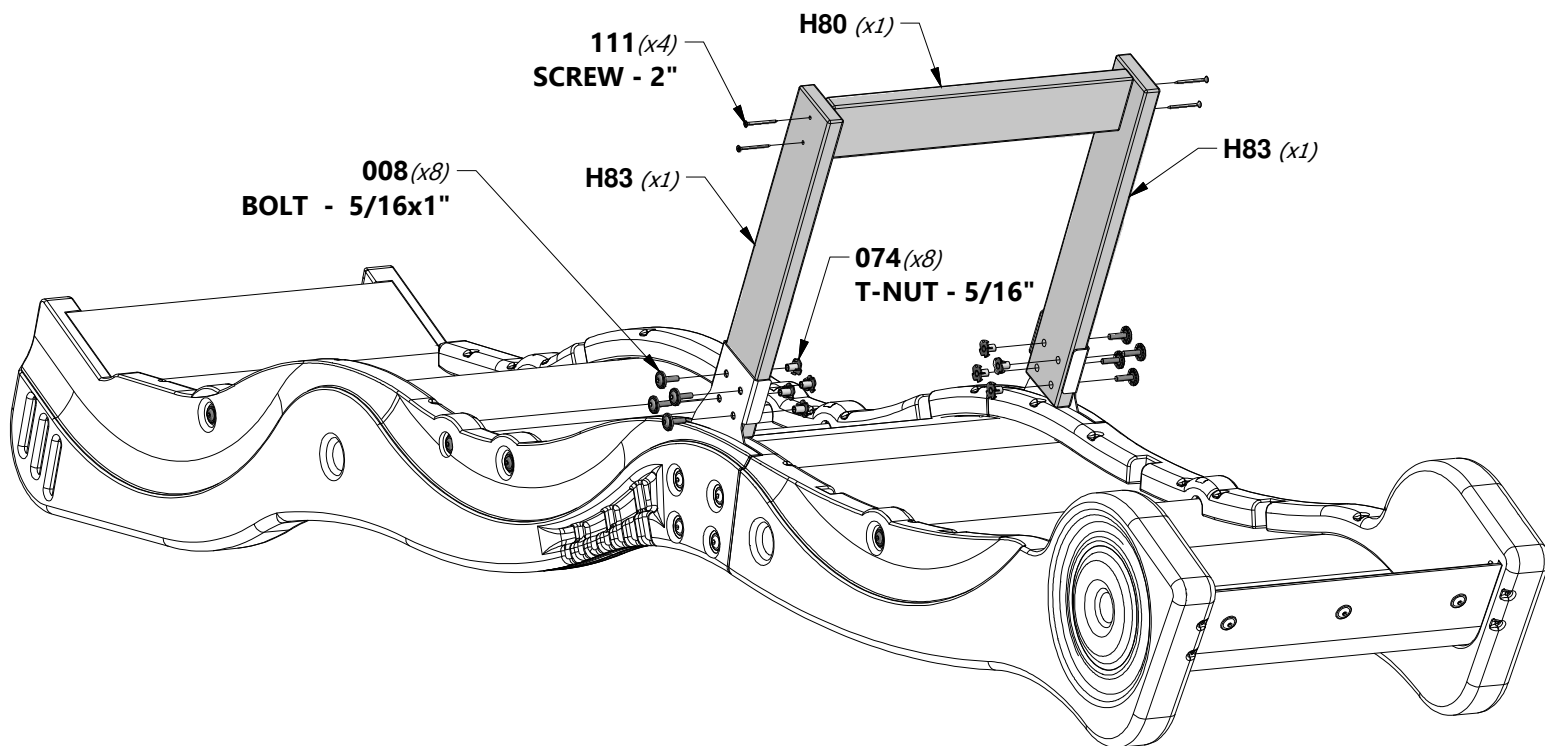



SWING BEAM ASSEMBLY

STEP 1

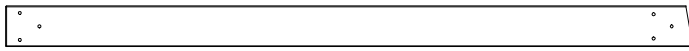

A1 | SWING BEAM - W4L13335
(x1) 3 3/8"x5 1/4"x89 1/2" (86x134x2274)



A2 | SB 9" BLOCK - W4L13337
(x1) 3 3/8"x5 1/4"x9" (86x134x228)



H100416 | BOLT WH BLK
(x10) 5/16x3



H100192 | NUT BARREL WH BLK
(x10) 5/16x7/8

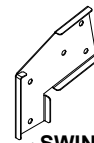

A100325 | SWING BEAM
EXTENSION
BRACKET-LEFT
(x1)

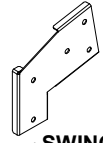

A100326 | SWING BEAM
EXTENSION
BRACKET-RIGHT
(x1)

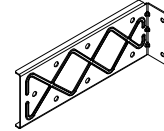

A4M00993 | EXTENDED SWING
BEAM BRACKET
(x2)

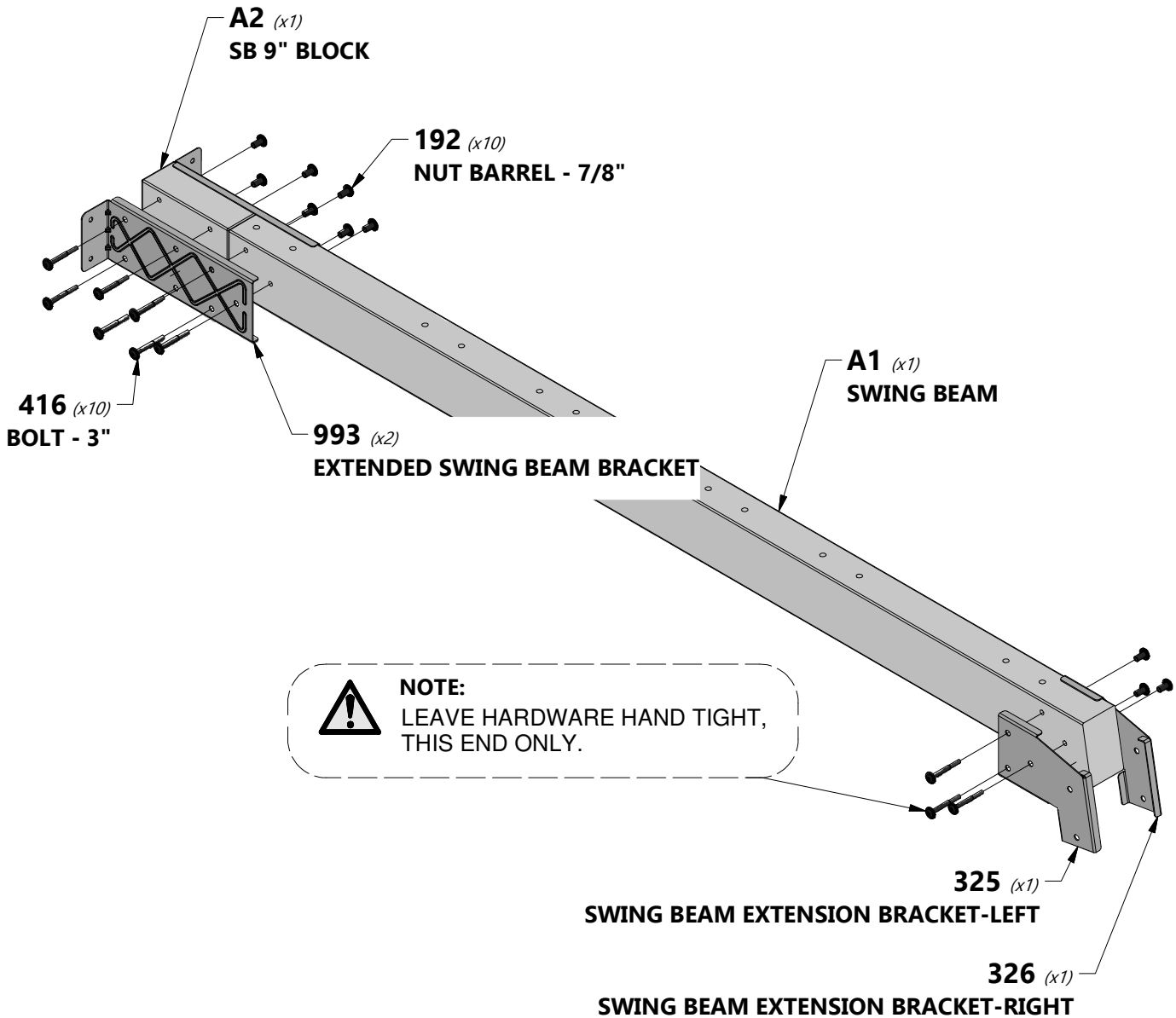

NOTE:
 LEAVE HARDWARE HAND TIGHT,
THIS END ONLY.



SWING BEAM ASSEMBLY

STEP 2



H100654 | BOLT HEX
(x12) | 3/8x5-1/2



H100107 | WASHER LOCK
(x12) | INT
10x18

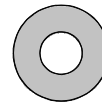

H100102 | WASHER FLAT
(x12) | 11x25

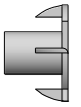

H100073 | T-NUT
(x12) | 3/8

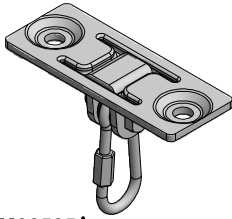

A4M00505 | SWING HANGER
(x6)



H100543 | SCREW PFH SD
(x4) | 8x1/2



A100164 | BYD ID PLATE 2011
(x1) | ASSEMBLY

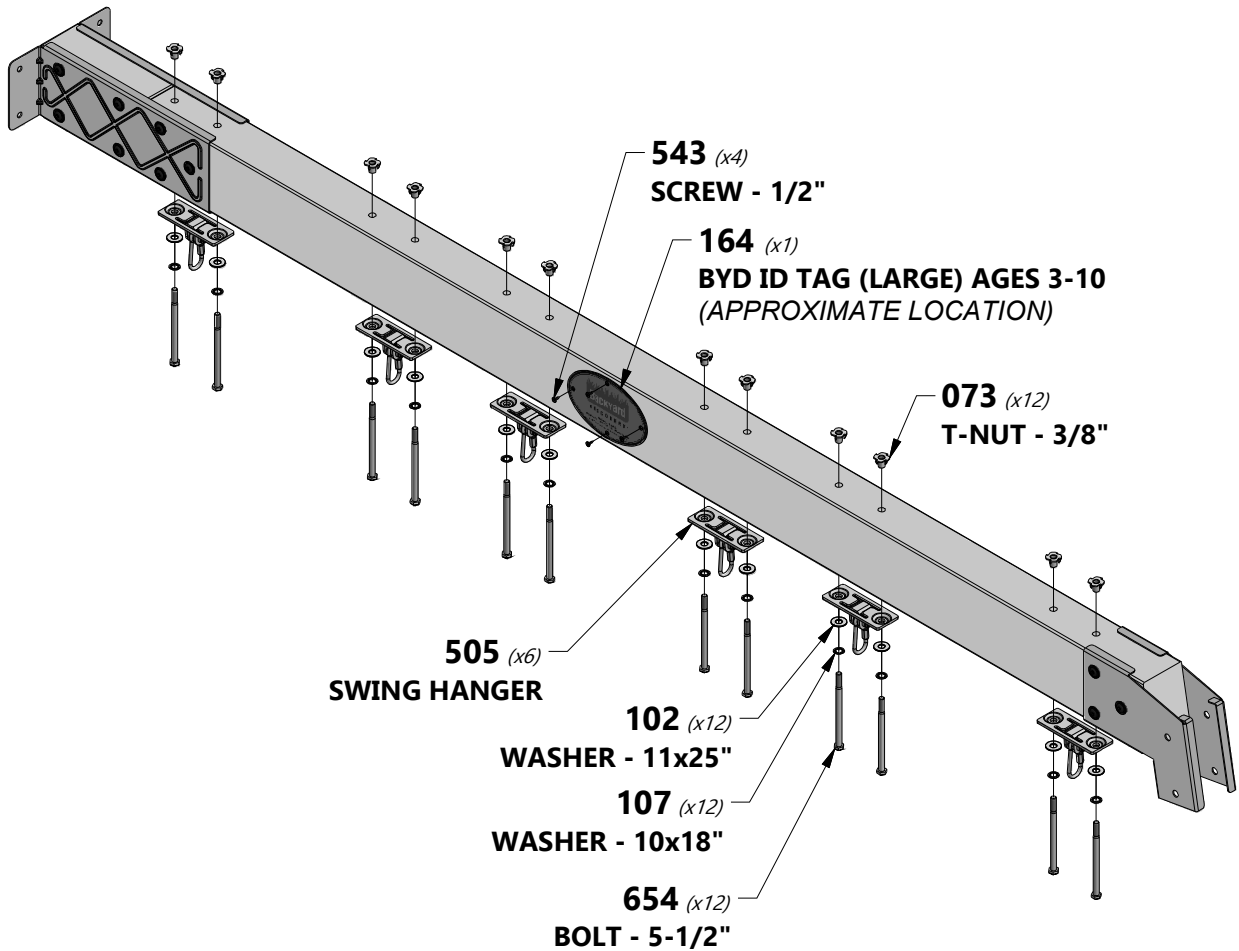



SWING BEAM ASSEMBLY

STEP 3

E50 | END SUPPORT - W4L13208
(x1) | 1 7/16"x3 3/8"x49 1/4" (36x86x1251)

E51 | ANGLE BRACE - W4L13206
(x2) | 1 7/16"x3 3/8"x80 1/2" (36x86x2045)

G50 | GROUND BOARD - W4L13207
(x1) | 15/16"x5 1/4"x87 3/4" (24x134x2230)

SP50 | SWING BEAM SUPPORT - W4L13336
(x1) | 3 3/8"x3 3/8"x49 3/8" (86x86x1254)

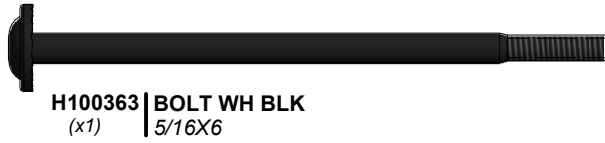

H100363 | BOLT WH BLK
(x1) | 5/16x6

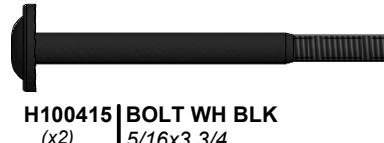

H100415 | BOLT WH BLK
(x2) | 5/16x3 3/4

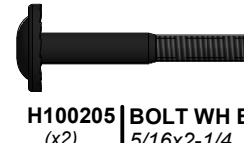

H100205 | BOLT WH BLK
(x2) | 5/16x2-1/4



H100199 | WASHER LOCK
(x9) | EXT BLK
12x19

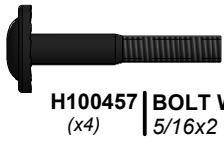

H100457 | BOLT WH BLK
(x4) | 5/16x2



H100193 | NUT BARREL WH
(x2) | BLK
5/16x1-1/2



H100192 | NUT BARREL WH
(x7) | BLK
5/16x7/8



H100198 | WASHER LOCK
(x9) | EXT BLK
8x19

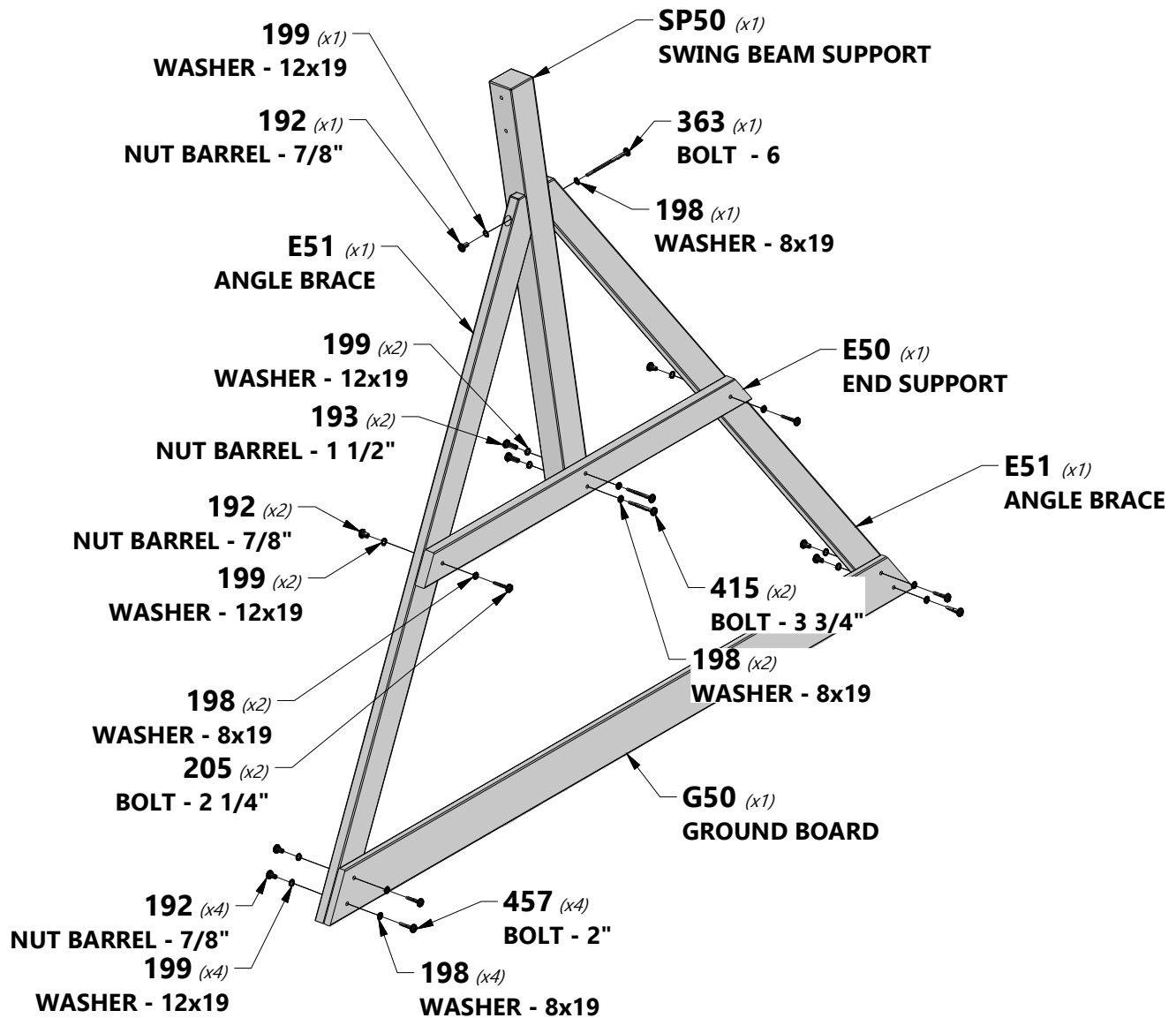



SWING BEAM ASSEMBLY

STEP 4



H100416 | BOLT WH BLK
(x2) | 5/16x3



H100192 | NUT BARREL WH BLK
(x2) | 5/16x7/8

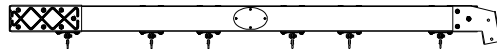

(x1) SWING BEAM ASSEMBLY

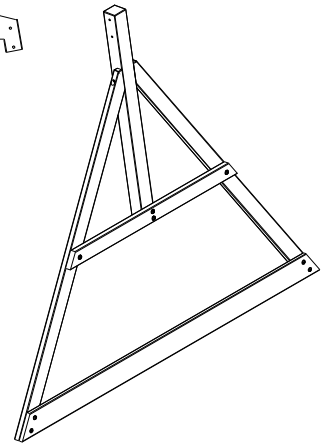

(x1) END FRAME ASSEMBLY

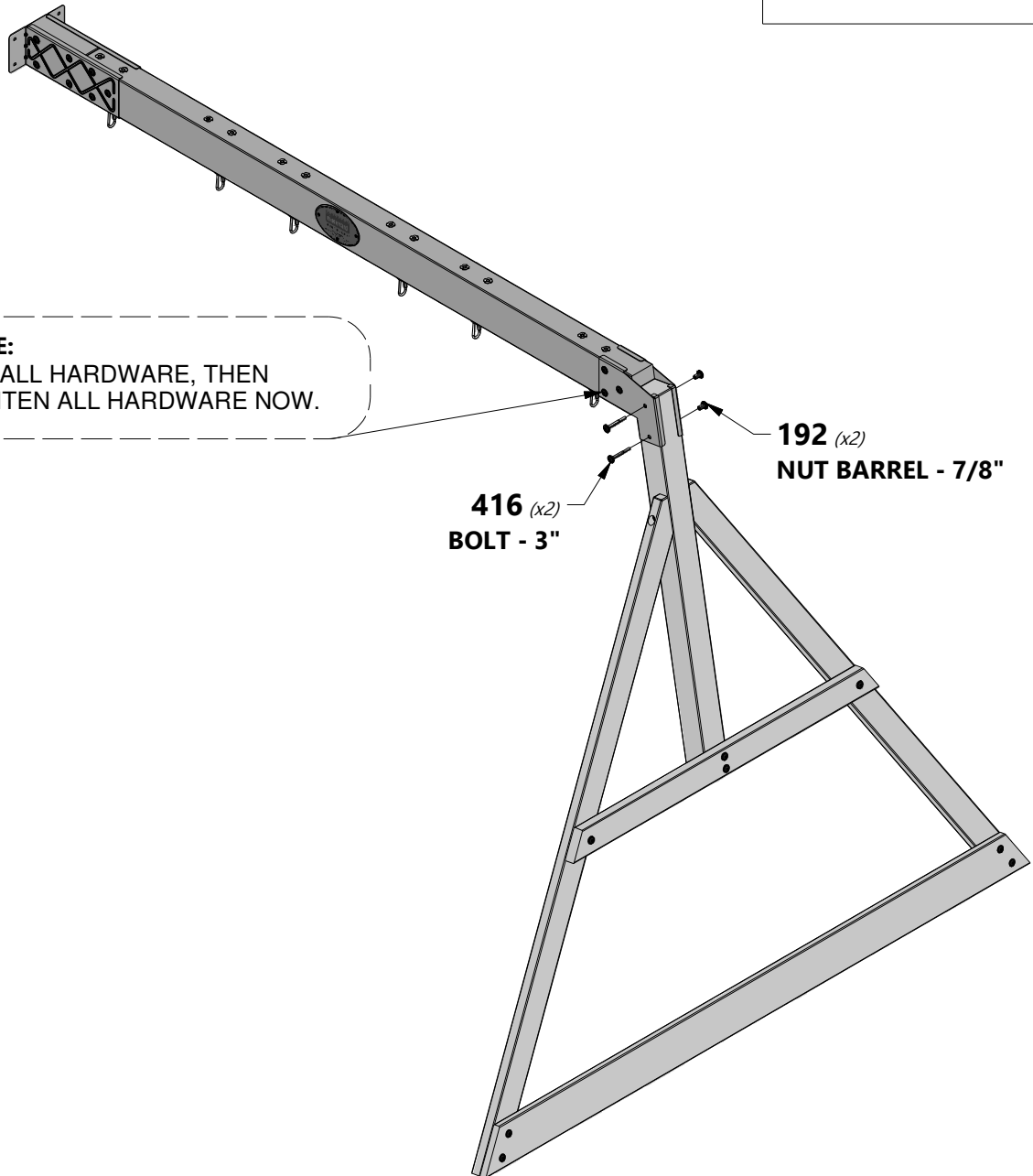

NOTE:
INSTALL HARDWARE, THEN
TIGHTEN ALL HARDWARE NOW.

416 (x2)
BOLT - 3"

192 (x2)
NUT BARREL - 7/8"



FORT ASSEMBLY

STEP 1

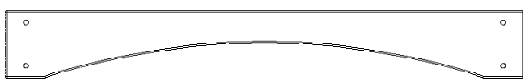

K12 | ARCHED WALL RAIL - W4L13192
(x1) | 5/8"x5 1/4"x40 5/8" (16x134x1032)



E7 | UPRIGHT - W4L13183
(x1) | 1 3/8"x3 3/8"x16 1/8" (36x86x411)



E9 | UPRIGHT - W4L13185
(x1) | 1 3/8"x3 3/8"x16 1/8" (36x86x411)



H100457 | BOLT WH BLK
(x4) | 5/16x2



H100379 | T-NUT BLK
(x4) | 5/16



H100198 | WASHER LOCK
(x4) | EXT BLK
8x19

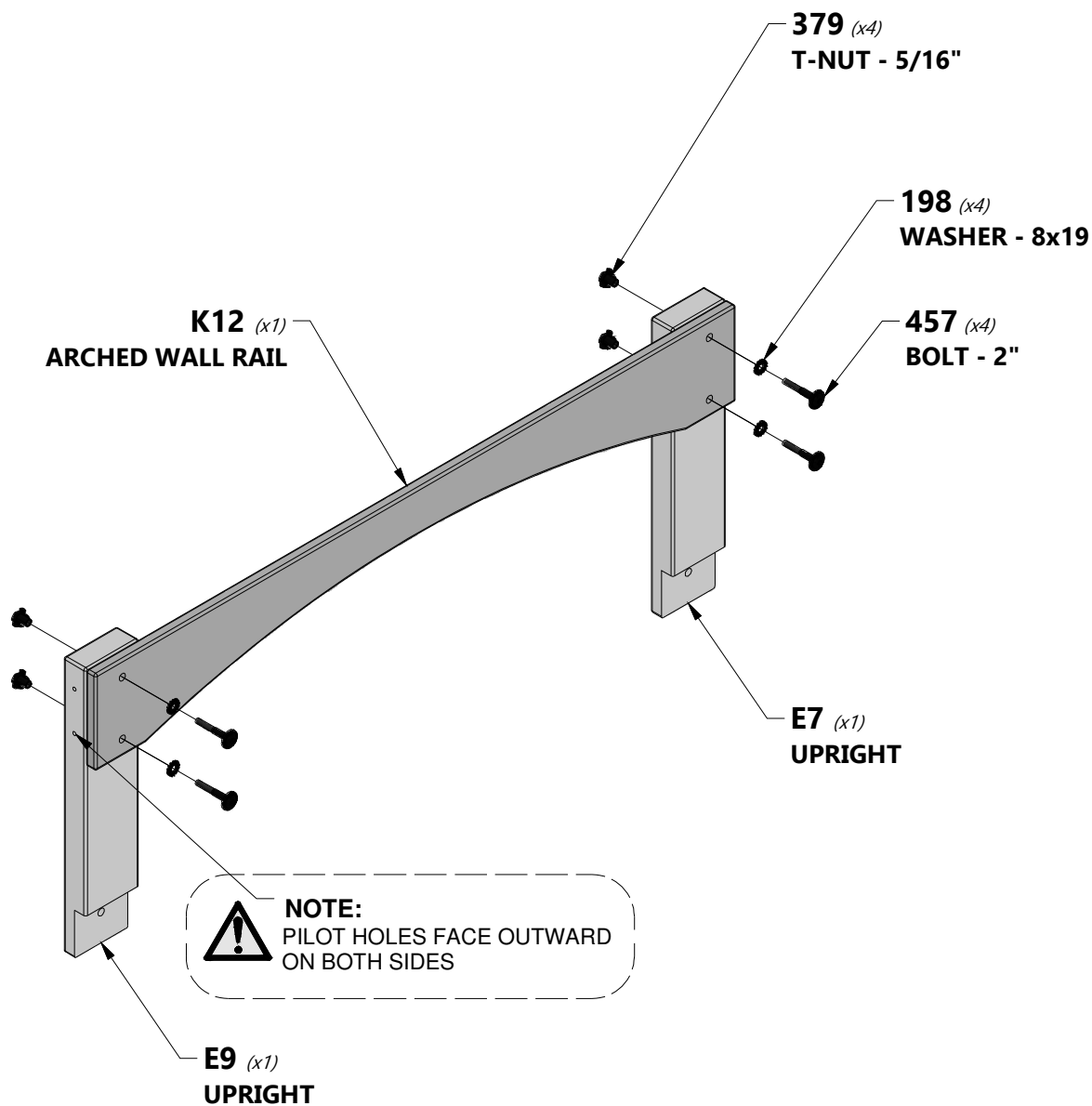



FORT ASSEMBLY

STEP 2

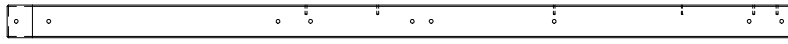

E4 | UPRIGHT - W4L13168
(x1) | 1 3/8"x3 3/8"x81 5/8" (36x86x2074)

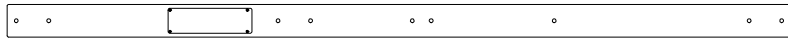

E1 | REAR UPRIGHT - W2A02660
(x1) | 1 3/8"x3 3/8"x51 3/4" (36x86x2074)



K5 | WALL RAIL - W4L13169
(x1) | 5/8"x5 1/4"x63" (16x134x1601)

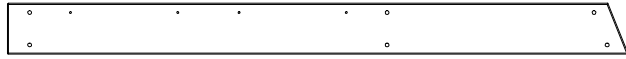

K1 | GROUND BOARD - W4L13162
(x1) | 5/8"x5 1/4"x64 3/4" (16x134x1644)

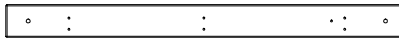

M5 | WALL RAIL - W4L13311
(x1) | 5/8"x3 3/8"x41 1/4" (16x86x1048)



A100314 | "A" REVISION TAG
(x1)



H100457 | BOLT WH BLK
(x14) | 5/16x2



H100459 | BOLT WH BLK
(x4) | 5/16x1 1/4



H100198 | WASHER LOCK EXT BLK
(x18) | 8x19



H100128 | SCREW PWH
(x2) | 8x5/8



H100379 | T-NUT BLK
(x18) | 5/16



E13 | DECK BRACE - W4L13314
(x1) | 1 3/8"x3 3/8"x23 5/8" (36x86x600)



E14 | DECK BRACE - W4L13315
(x1) | 1 3/8"x3 3/8"x23 5/8" (36x86x600)



NOTE:
ENSURE TO ASSEMBLE WOOD AS SHOWN, USE PILOT HOLES AS REFERENCE.

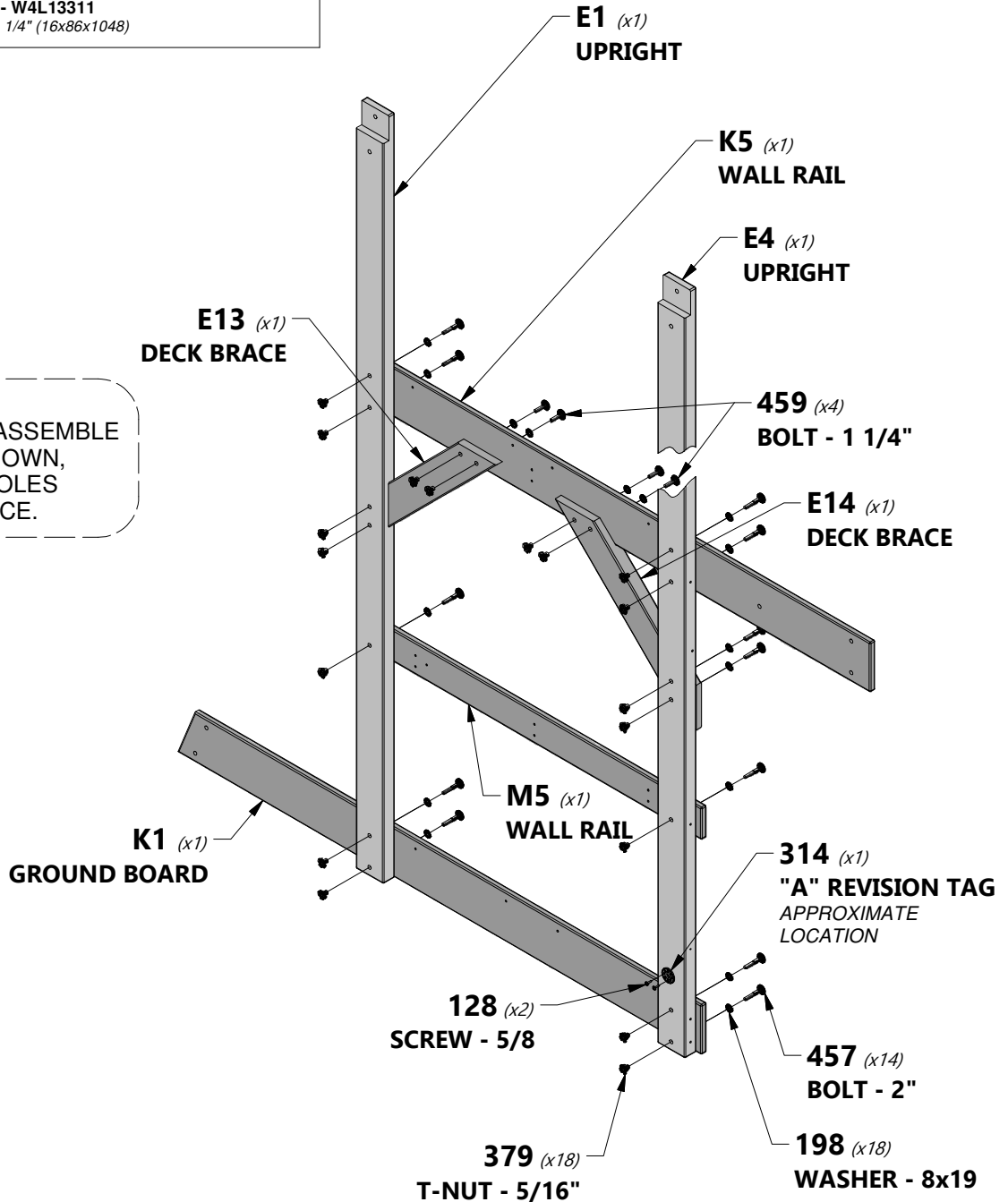



FORT ASSEMBLY

STEP 3

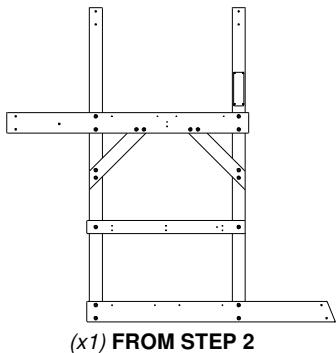

(x1) FROM STEP 2

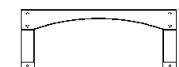

(x1) FROM STEP 1

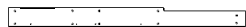

G1 | SWING BEAM MOUNT - W4L13186
(x1) | 1"x5 1/4"x62 1/8" (24x134x1577)



H100205 | BOLT WH BLK
(x4) | 5/16x2-1/4



H100379 | T-NUT BLK
(x8) | 5/16



H100198 | WASHER LOCK
(x4) | EXT BLK
8x19

379 (x8)
T-NUT - 5/16"

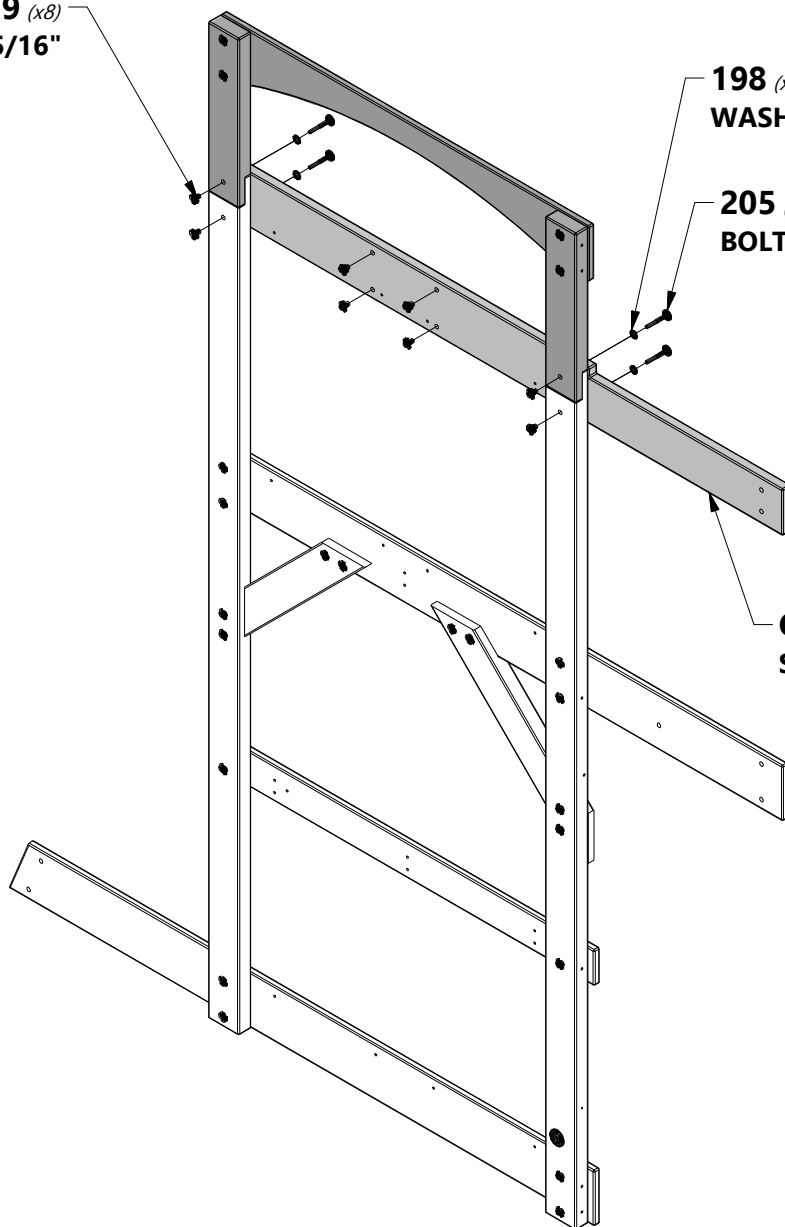

198 (x4)
WASHER - 8x19

205 (x4)
BOLT - 2 1/4"

G1 (x1)
SWING BEAM MOUNT

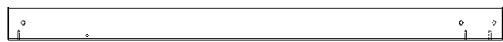

E2 UPRIGHT - W4L13166
(x1) | 1 3/8"x3 3/8"x51 3/4" (36x86x1314)

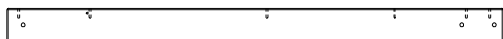

E3 UPRIGHT - W4L13167
(x1) | 1 3/8"x3 3/8"x51 3/4" (36x86x1314)

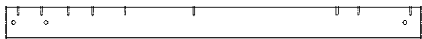

E6 UPRIGHT - W4L13182
(x1) | 1 3/8"x3 3/8"x43 1/2" (36x86x1104)

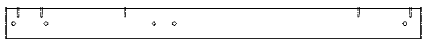

E8 UPRIGHT - W4L13184
(x1) | 1 3/8"x3 3/8"x43 1/2" (36x86x1104)



K2 GROUND BOARD - W4L13163
(x1) | 5/8"x5 1/4"x64 11/16" (16x134x1644)



K8 WALL RAIL - W4L13172
(x1) | 5/8"x5 1/4"x40 5/8" (16x134x1032)



K13 ARCHED WALL RAIL - W4L13193
(x1) | 5/8"x5 1/4"x40 5/8" (16x134x1032)



H100457 BOLT WH BLK
(x12) | 5/16x2



H100198 WASHER LOCK
(x12) | EXT BLK
8x19



H100379 T-NUT BLK
(x12) | 5/16

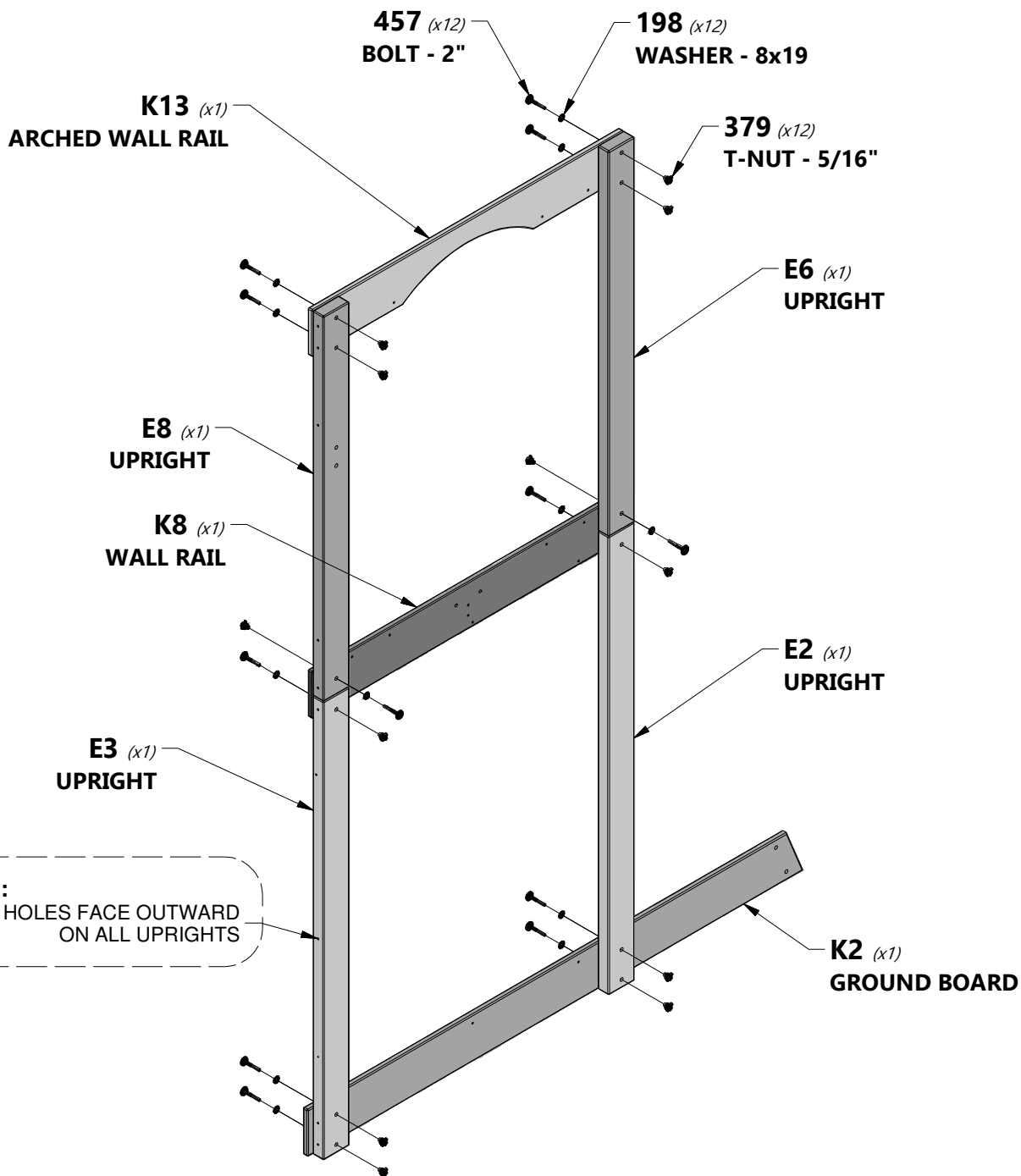



FORT ASSEMBLY

STEP 5

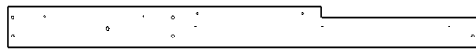

G3 | WALL RAIL - W4L13170
(x1) | 1"x5 1/4"x61 3/8" (24x134x1560)

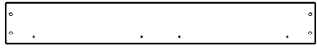

K4 | GROUND BOARD - W4L13165
(x1) | 5/8"x5 1/4"x40 1/2" (16x134x1030)



K15 | ANGLED WALL RAIL - W4L13195
(x1) | 5/8"x5 1/4"x45 3/4" (16x134x1162)

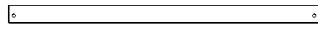

J1 | PORCH GROUND BOARD - W4L13177
(x1) | 1"x2 3/8"x40 1/2" (24x60x1030)

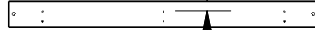

M1 | WALL RAIL - W4L13200
(x1) | 5/8"x3 3/8"x40 1/2" (16x86x1030)

1 3/8 in
[35 mm]



H100206 | LAG SCREW WH BLK
(x2) | 5/16x3



H100458 | LAG SCREW WH BLK
(x2) | 5/16x2



H100197 | LAG SCREW WH BLK
(x1) | 5/16x2 1/2



H100471 | LAG SCREW WH BLK
(x8) | 5/16x1 1/2



A4M00710 | L BRACKET
(x1) | BLACK 32x51



H100198 | WASHER LOCK
(x12) | EXT BLK
8x19

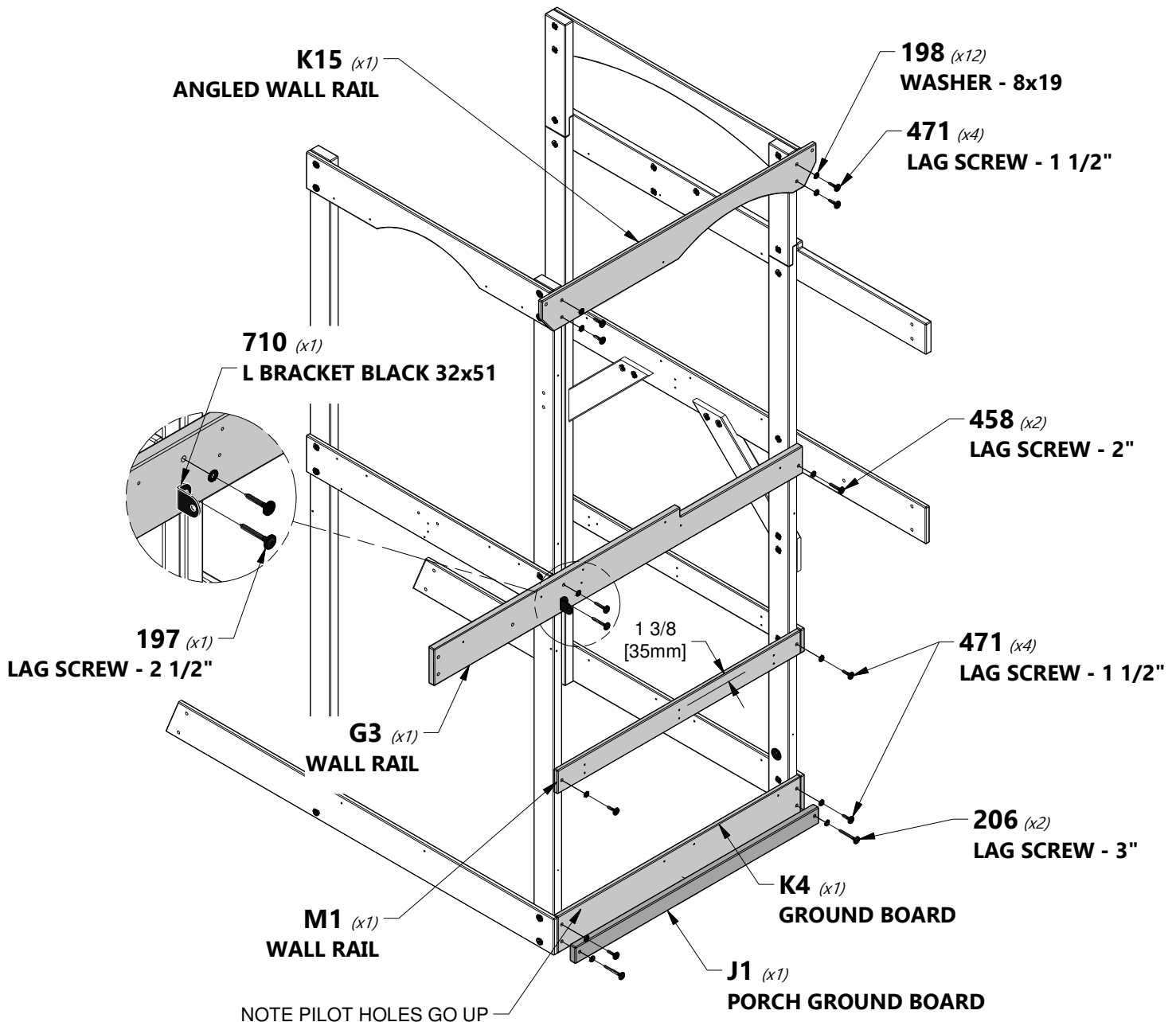

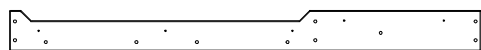

G2 | WALL RAIL - W4L13171
(x1) | 1"x5 1/4"x61 3/8" (24x134x1560)

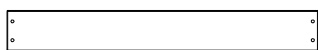

K3 | GROUND BOARD - W4L13164
(x1) | 5/8"x5 1/4"x40 1/2" (16x134x1030)

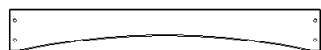

K6 | ARCHED WALL RAIL - W4L13190
(x1) | 5/8"x5 1/4"x40 1/2" (16x134x1030)

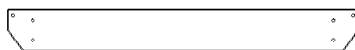

K14 | ANGLED WALL RAIL - W4L13194
(x1) | 5/8"x5 1/4"x45 3/4" (16x134x1162)



H100458 | LAG SCREW WH BLK
(x4) | 5/16x2



H100198 | WASHER LOCK
(x16) | EXT BLK
8x19



H100471 | LAG SCREW WH BLK
(x12) | 5/16x1 1/2

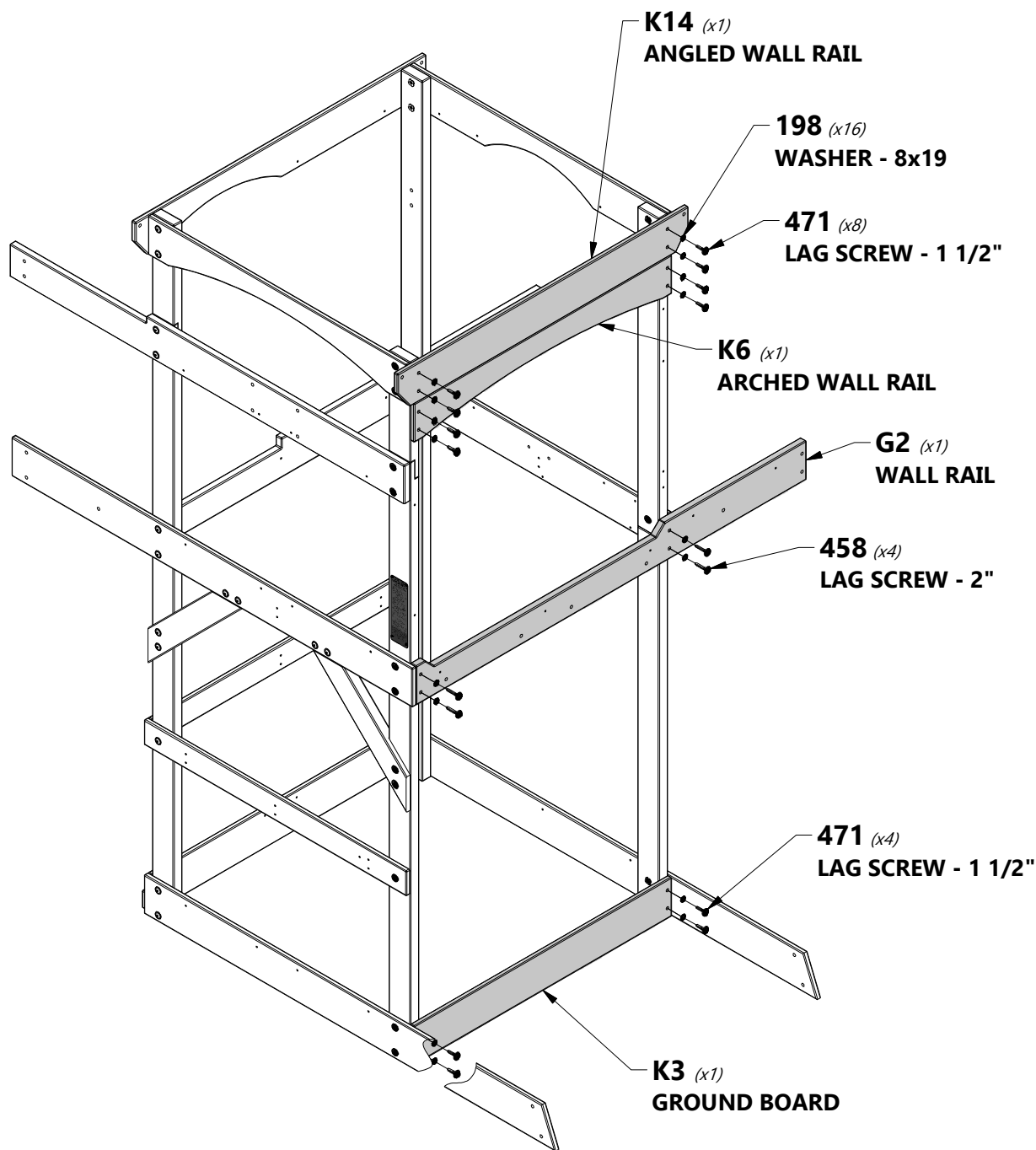



F2 | BALCONY UPRIGHT - W4L13180
(x2) | 1 3/8"x2 3/8"x34 5/8" (36x60x881)



J11 | WALL RAIL - W4L13204
(x2) | 1"x2 3/8"x22 1/4" (24x60x566)



J12 | WALL RAIL - W4L13188
(x2) | 1"x2 3/8"x23 1/4" (24x60x590)



H100458 | LAG SCREW WH BLK
(x12) | 5/16x2



**H100198 | WASHER LOCK
EXT BLK**
(x12) | 8x19

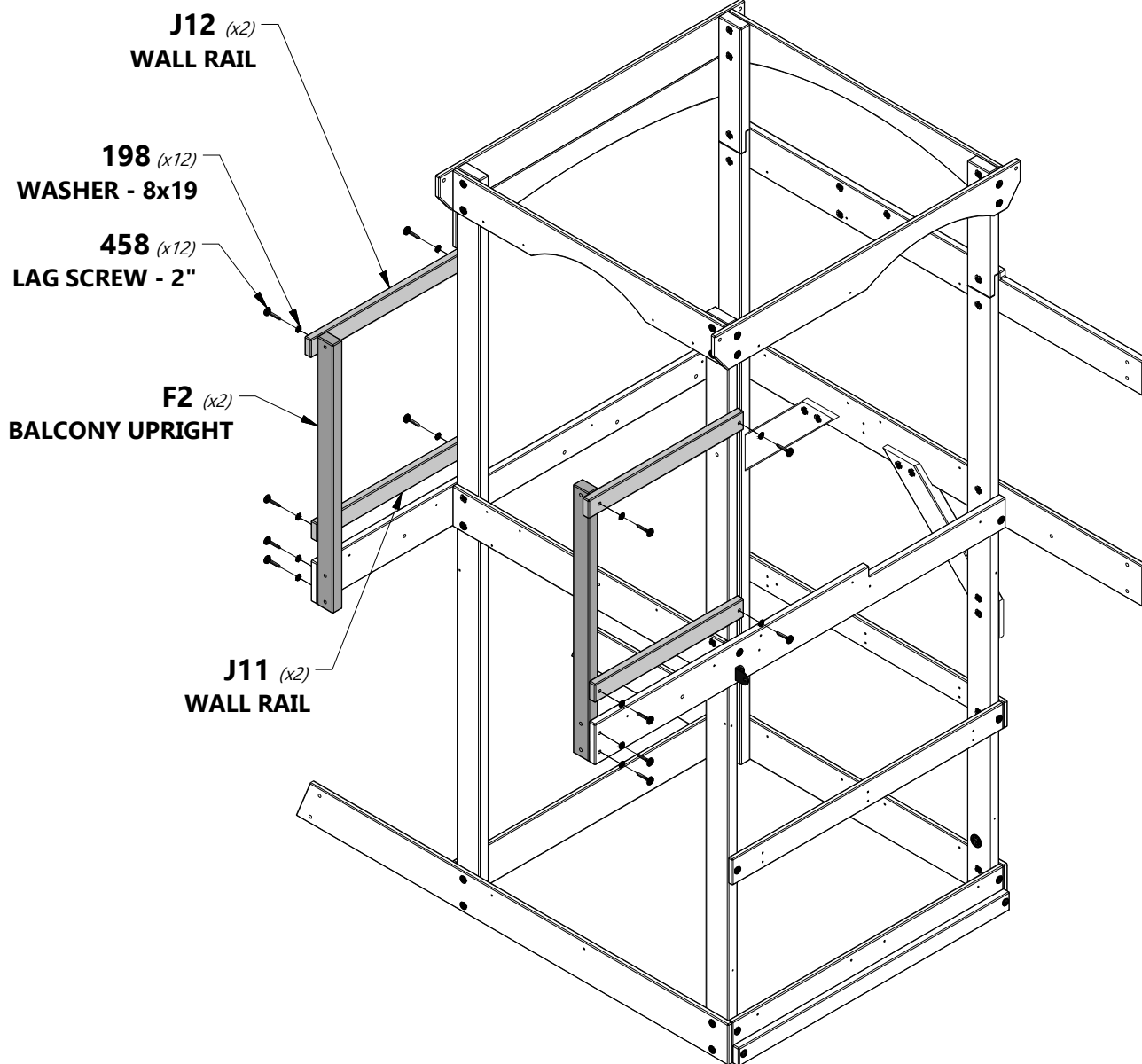



FORT ASSEMBLY

STEP 8



G4 | WALL BOARD - W4L13181
(x1) | 1"x5 1/4"x42 1/2" (24x134x1080)



J7 | WALL RAIL - W4L13191
(x1) | 1"x2 3/8"x40 5/8" (24x60x1032)



H100205 | BOLT WH BLK
(x6) | 5/16x2-1/4



H100379 | T-NUT BLK
(x6) | 5/16



H100198 | WASHER LOCK
(x6) | EXT BLK
8x19

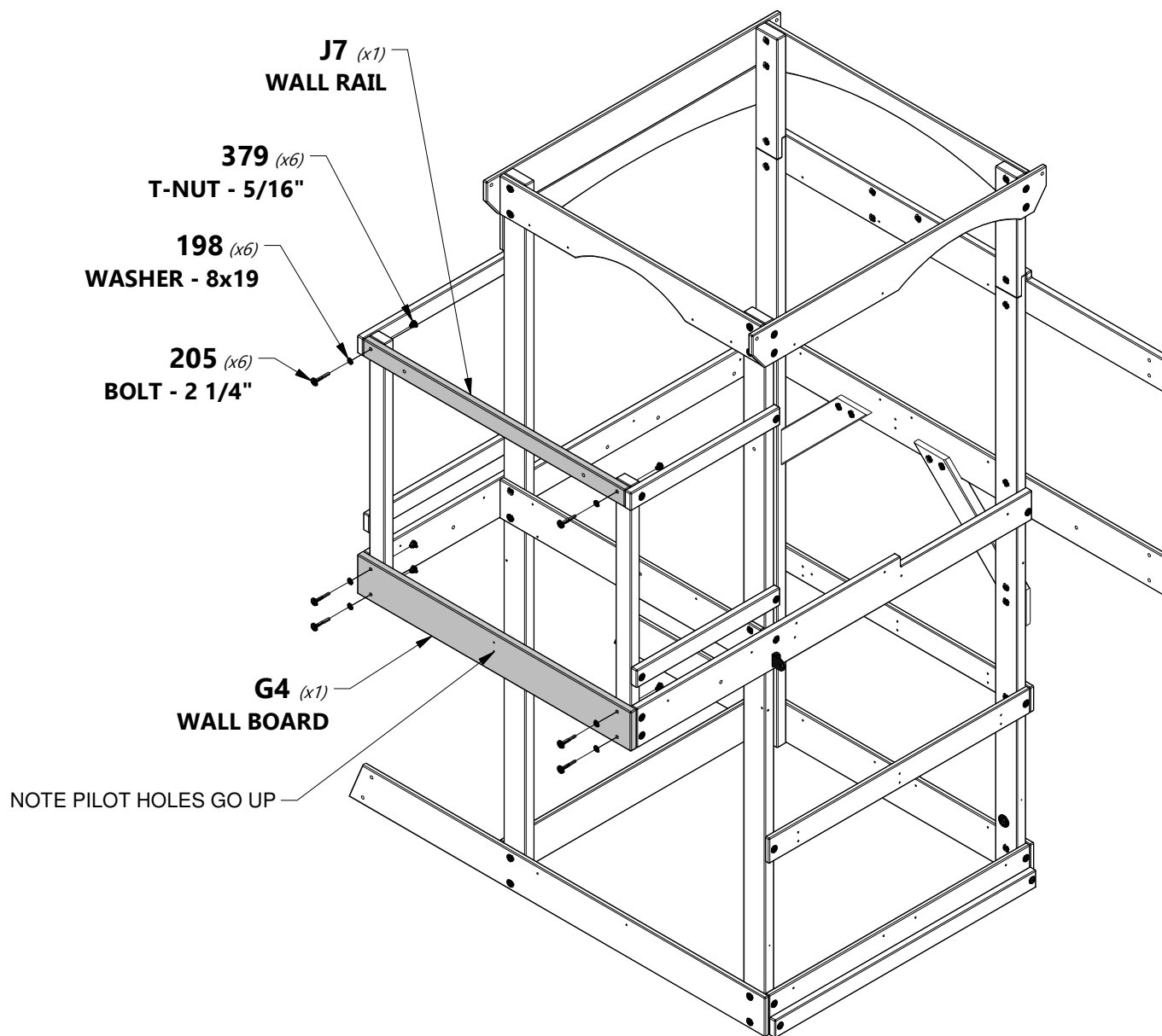



H3 | DECK BRACE - W4L13202
 (x2) | 1"x3 3/8"x15 3/4" (24x86x400)

H100378 | BOLT WH BLK
 (x2) | 5/16x1 3/4

H100198 | WASHER LOCK
 (x2) | EXT BLK
 8x19

H100379 | T-NUT BLK
 (x2) | 5/16

H100487 | LAG SCREW WH BLK
 (x2) | 1/4x2

H100405 | WASHER LOCK
 (x2) | EXT BLK
 6x15

REPEAT ON BOTH ENDS

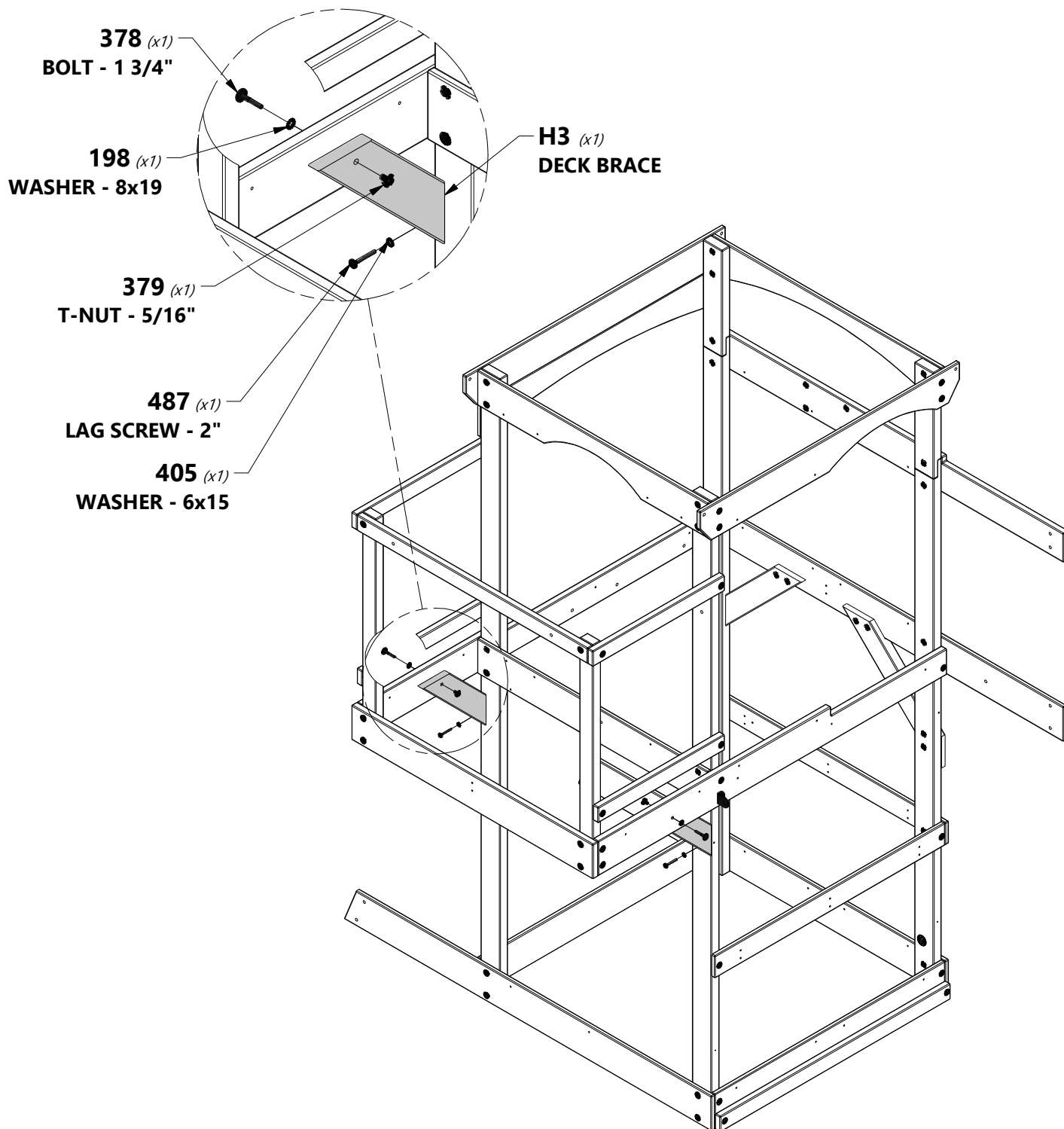



FORT ASSEMBLY

STEP 10

K9 WALL RAIL - W4L13173
 (x1) 5/8"x5 1/4"x20 1/2" (16x134x521)

N1 PORCH GROUND BOARD - W4L13176
 (x2) 5/8"x2 3/8"x21 1/8" (16x60x537)

L3 WALL RAIL - W4L13189
 (x1) 5/8"x4 3/8"x24 7/8" (16x112x631)

H100457 BOLT WH BLK
 (x2) 5/16x2

H100396 BOLT WH BLK
 (x1) 5/16x1/2

H100469 NUT BARREL
 WH BLK
 (x1) 5/16x5/8

H100198 WASHER LOCK
 EXT BLK
 (x2) 8x19

H100199 WASHER LOCK
 EXT BLK
 (x1) 12x19

H100379 T-NUT BLK
 (x2) 5/16

H100200 SCREW PFH BLK
 (x4) 8x1 1/2

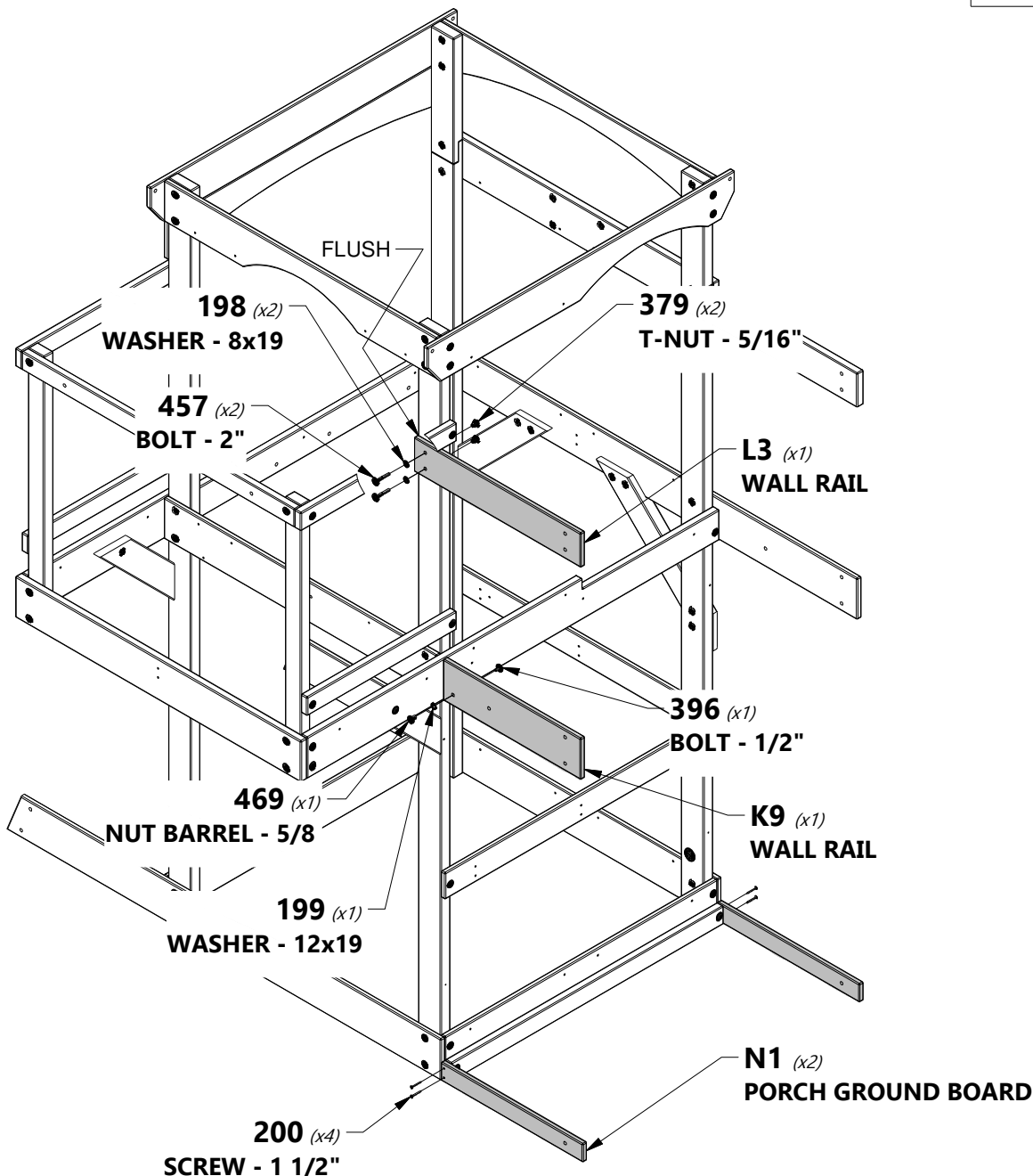

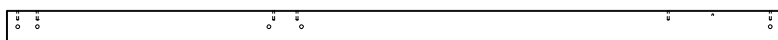

E5 UPRIGHT - W4L13175
(x1) | 1 3/8"x3 3/8"x80 3/4" (36x86x2052)



E11 UPRIGHT - W4L13203
(x1) | 1 3/8"x3 3/8"x80 3/4" (36x86x2052)



H100457 BOLT WH BLK
(x8) | 5/16x2



H100198 WASHER LOCK
(x10) | EXT BLK
8x19



H100205 BOLT WH BLK
(x2) | 5/16x2-1/4



H100379 T-NUT BLK
(x10) | 5/16

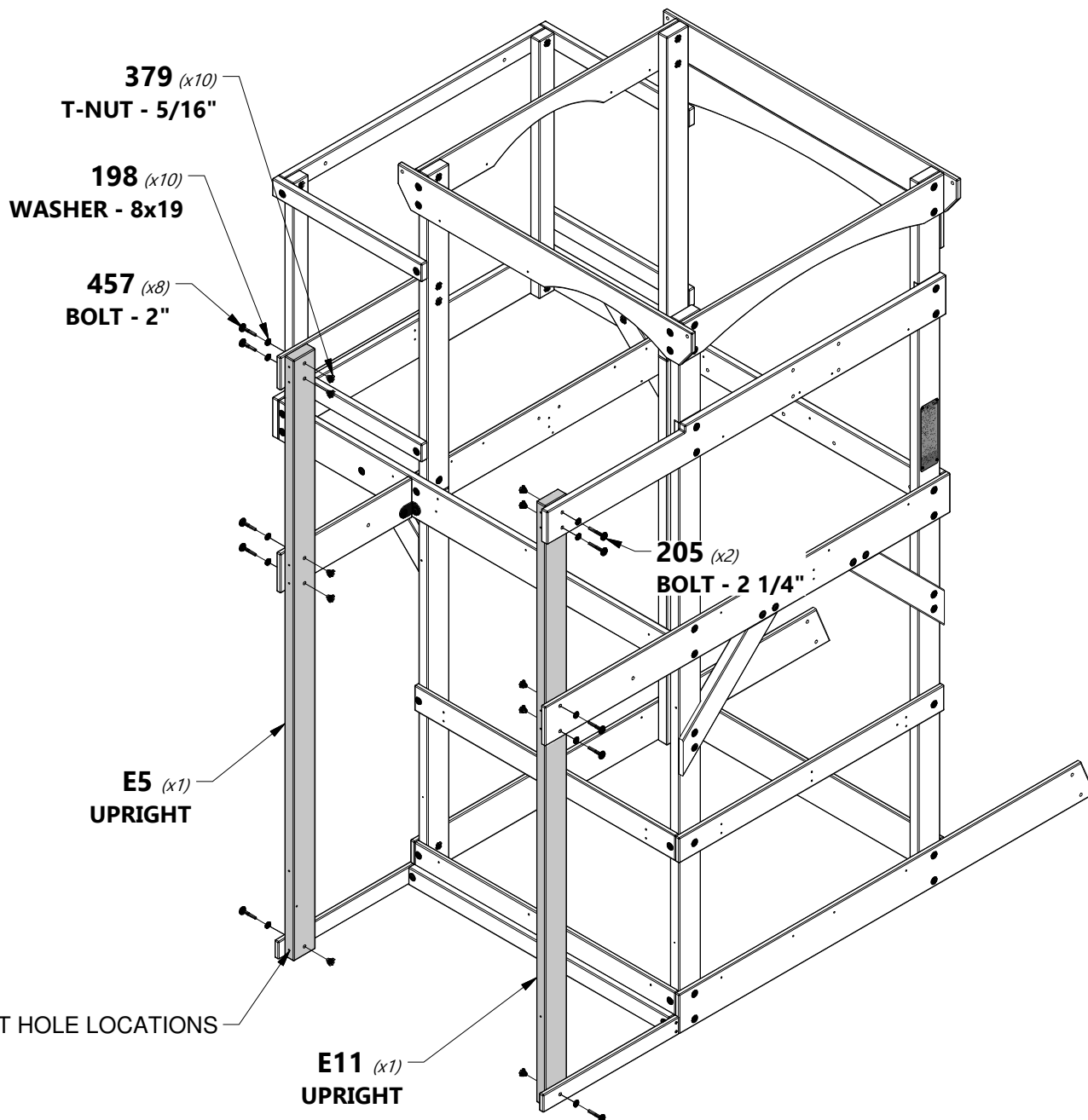

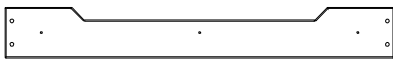

K10 | WALL RAIL - W4L13174
(x1) | 5/8"x5 1/4"x40 1/2" (16x134x1030)



L1 | ARCHED WALL RAIL - W4L13187
(x1) | 5/8"x4 3/8"x40 1/2" (16x112x1030)



J2 | PORCH GROUND BOARD - W4L13178
(x1) | 1"x2 3/8"x40 1/2" (24x60x1030)



H100458 | LAG SCREW WH BLK
(x2) | 5/16x2



H100471 | LAG SCREW WH BLK
(x8) | 5/16x1 1/2



H100198 | WASHER LOCK
(x10) | EXT BLK
8x19

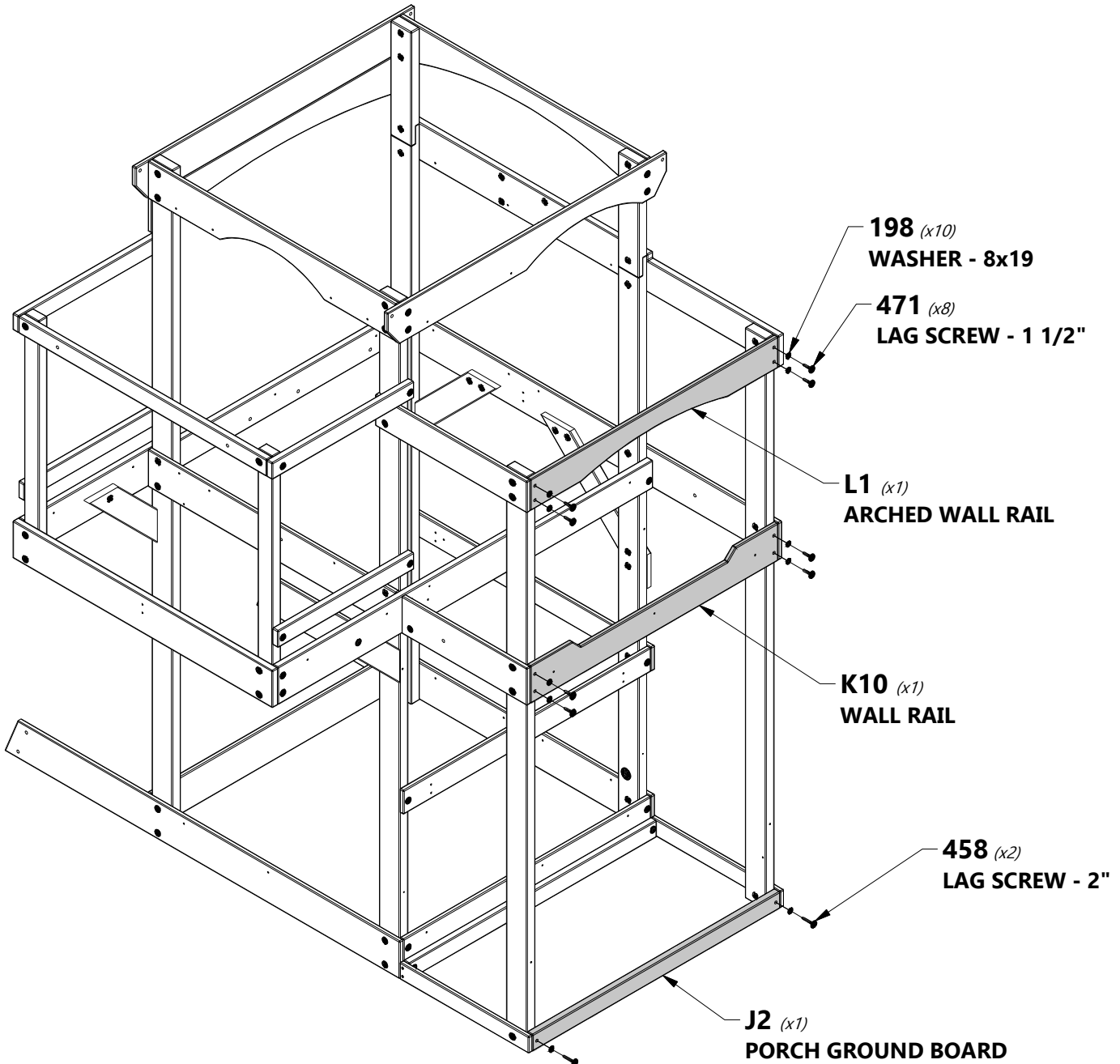



H4 | DECK BRACE - W4L13205
(x2) | 1"x3 3/8"x15 3/4" (24x86x400)



H100407 | BOLT WH BLK
(x2) | 5/16x1 1/2



H100198 | WASHER LOCK
(x2) | EXT BLK
8x19



H100379 | T-NUT BLK
(x2) | 5/16



H100487 | LAG SCREW WH BLK
(x2) | 1/4x2



H100405 | WASHER LOCK
(x2) | EXT BLK
6x15

REPEAT ON BOTH ENDS

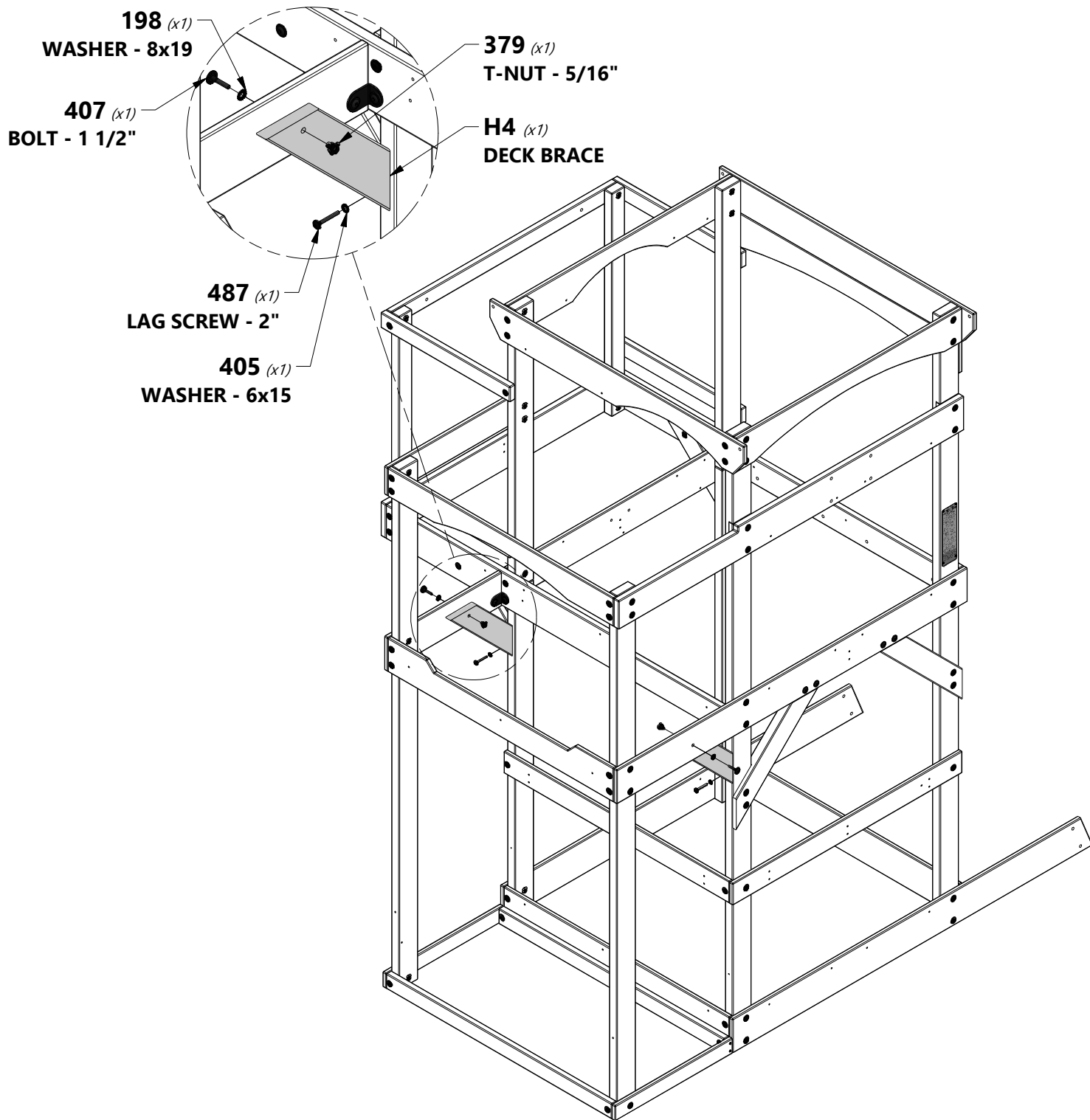



J8 | FLOOR JOIST - W4L07602
(x1) | 1"x2 3/8"x40 1/2" (24x60x1029)



T1 | SUPPORT BOARD - W4L07599
(x2) | 1"x1 3/8"x37 5/8" (24x34x957)



H100391 | SCREW PFH BLK
(x4) | 8x2



H100382 | SCREW PFH BLK
(x6) | 8x1 3/4

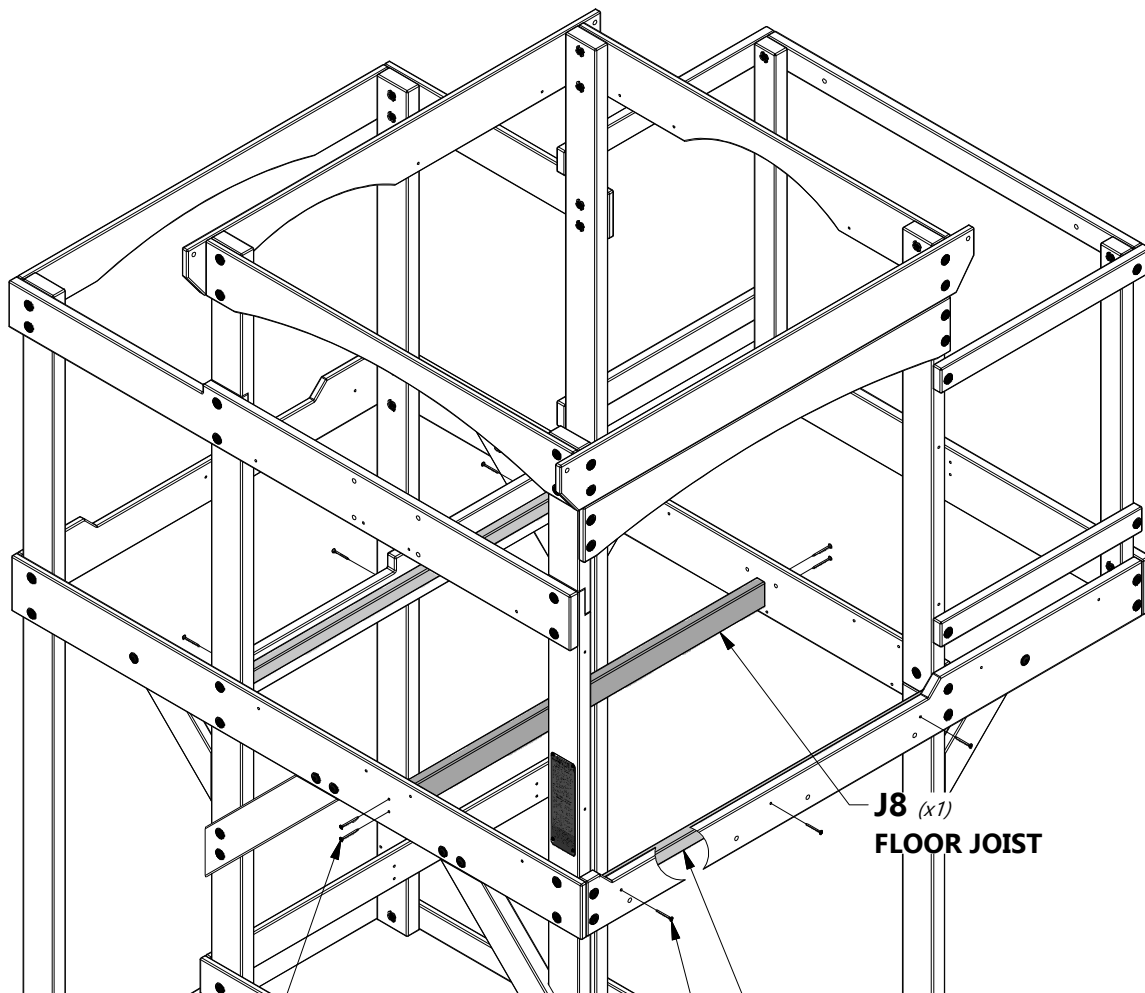

391 (x4)
SCREW - 2"

T1 (x2)
SUPPORT BOARD

J8 (x1)
FLOOR JOIST

382 (x6)
SCREW - 1 3/4"

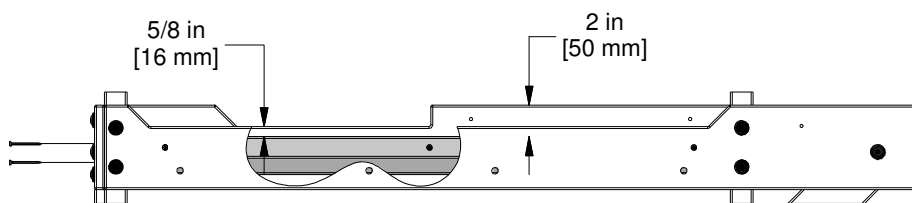

SIDE VIEW



FORT ASSEMBLY

STEP 15



J9 | FLOOR JOIST - W4L07603
(x1) | 1"x2 3/8"x20 1/4" (24x60x513)

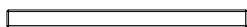

T3 | SUPPORT BOARD - W4L07601
(x2) | 1"x1 3/8"x18 3/4" (24x34x477)



A4M01110 | 90° L-BRACKET -
(x2) | BLK



H100486 | BOLT WH BLK
(x2) | 1/4x5/8



H100401 | BOLT WH BLK
(x1) | 1/4x1/2



H100391 | SCREW PFH BLK
(x2) | 8x2



H100399 | NUT BARREL
(x1) | WH BLK
1/4x7/8



H100398 | T-NUT BLK
(x2) | 1/4



H100382 | SCREW PFH BLK
(x4) | 8x1 3/4

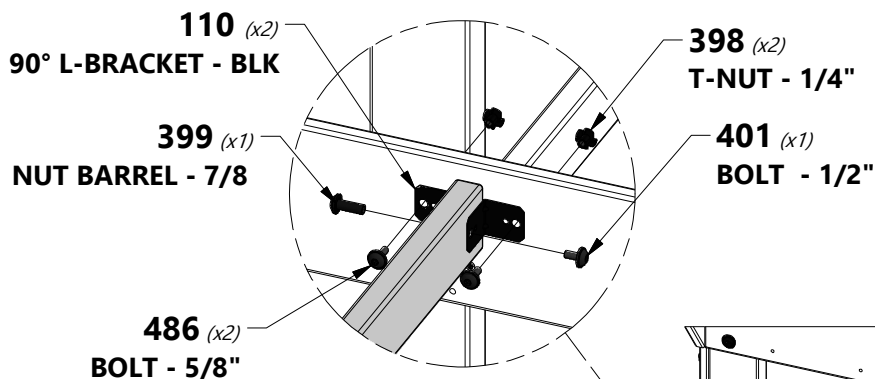

T3 (x2)
SUPPORT BOARD

382 (x4)
SCREW - 1 3/4"

J9 (x1)
FLOOR JOIST

391 (x2)
SCREW - 2"

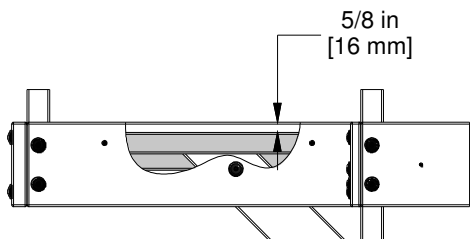

SIDE VIEW

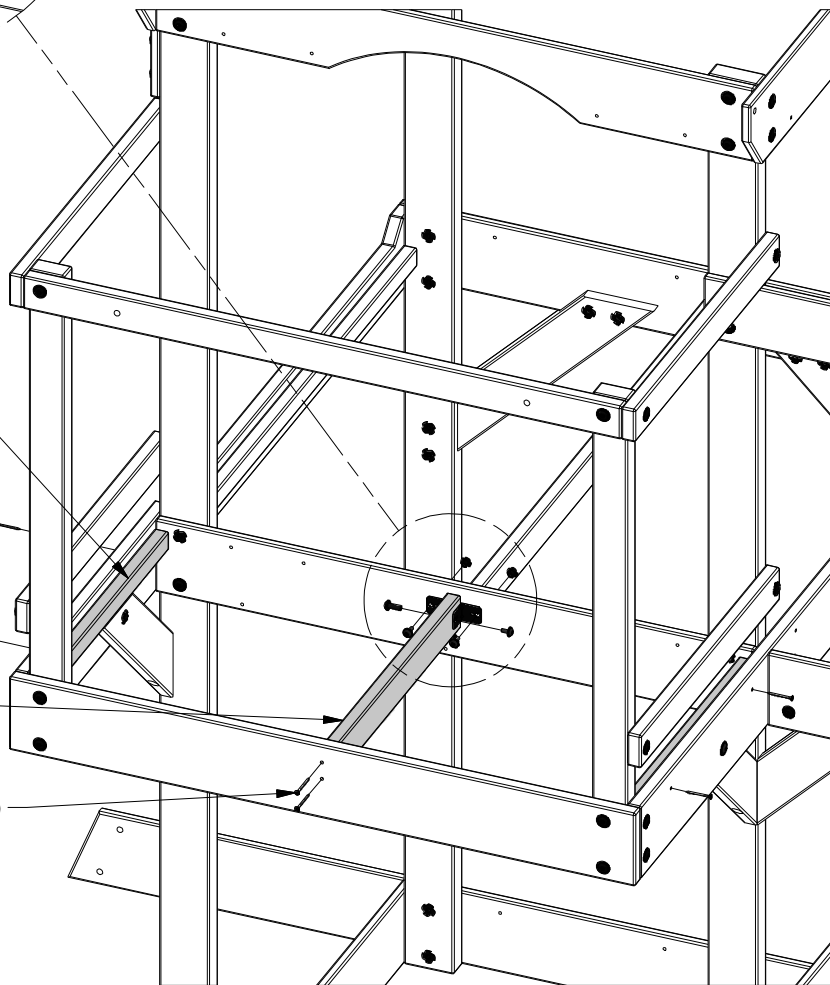

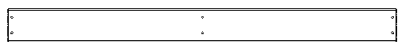

M11 | FLOOR BOARD - W4L13308
(x10) | 5/8"x3 3/8"x40 5/8" (16x86x1031)



M16 | FLOOR BOARD - W4L13307
(x1) | 5/8"x3 1/8"x40 5/8" (16x78x1031)



M17 | FLOOR BOARD - W4L13309
(x1) | 5/8"x3 3/8"x40 5/8" (16x86x1031)



H100086 | SCREW PFH
(x66) | 8x1 1/2



NOTE:

EVENLY SPACE FLOOR BOARDS

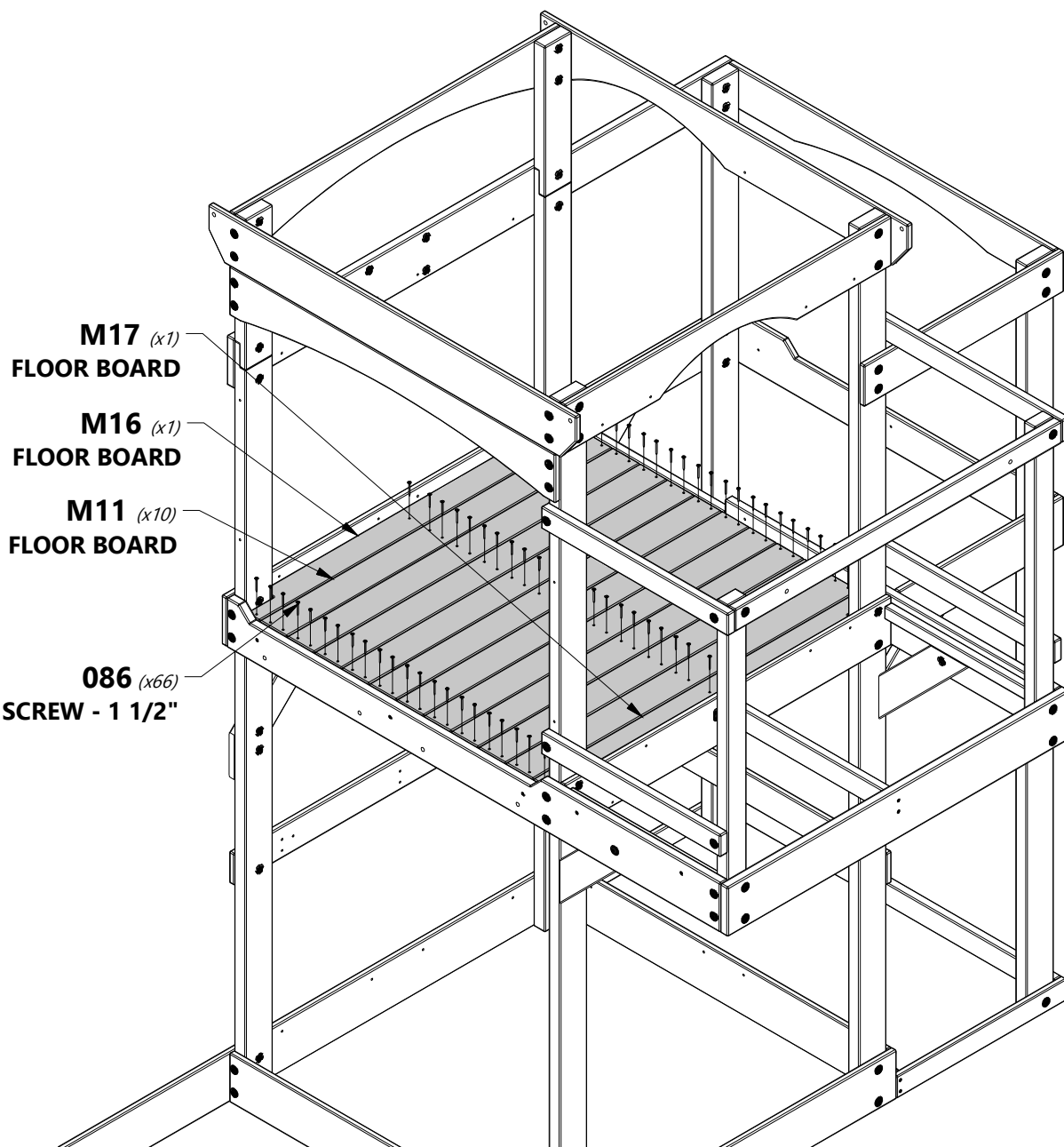

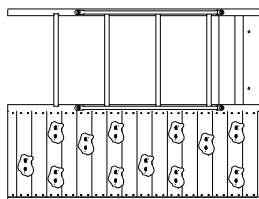

ASSEMBLY (x1) | **ROCKWALL LADDER**



H100457 | **BOLT WH BLK**
(x4) | 5/16x2



H100379 | **T-NUT BLK**
(x4) | 5/16



H100378 | **BOLT WH BLK**
(x4) | 5/16x1 3/4



H100198 | **WASHER LOCK**
(x8) | **EXT BLK**
8x19

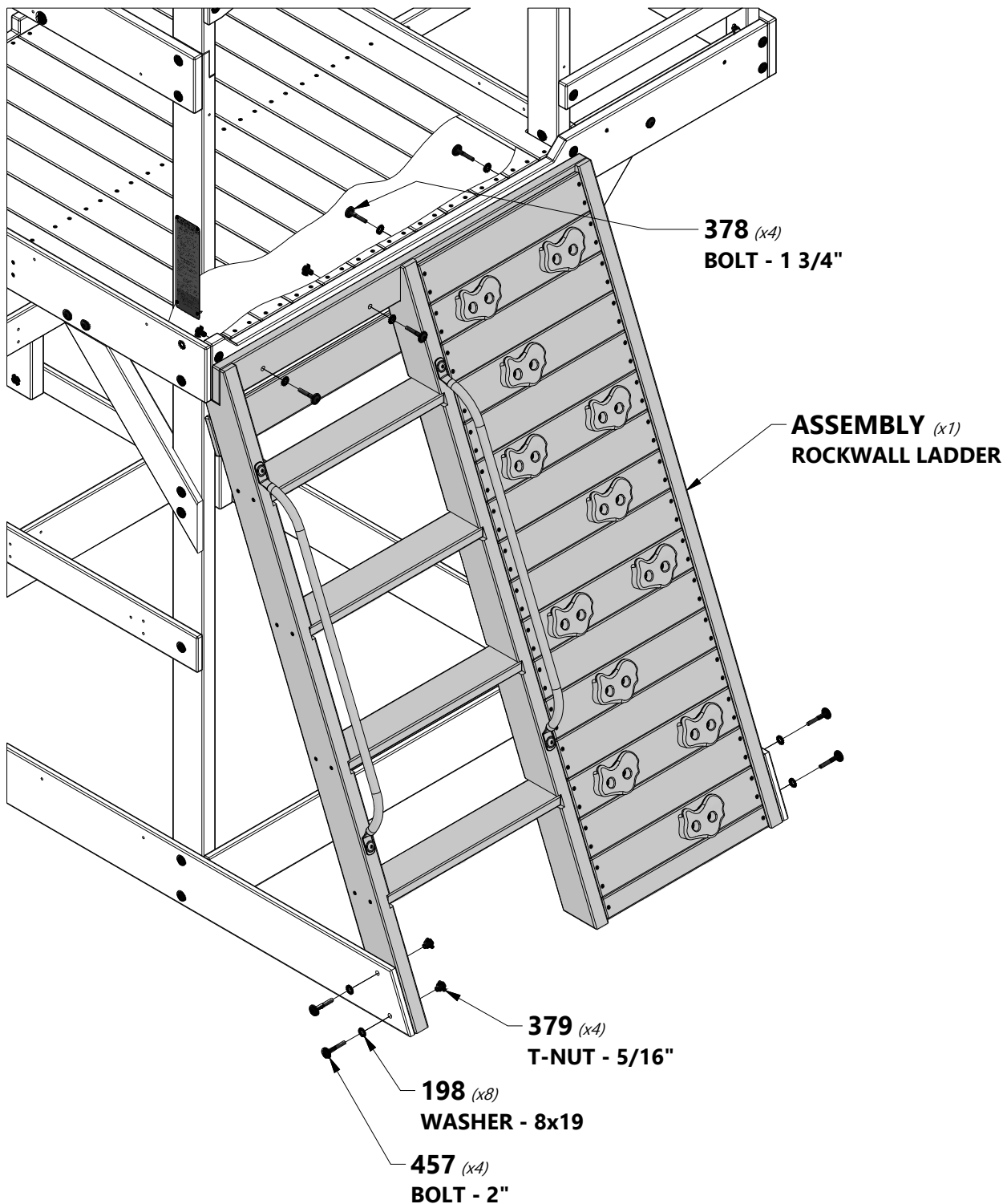

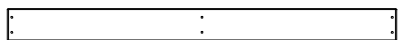

M11 | FLOOR BOARD - W4L13308
(x5) | 5/8"x3 3/8"x40 5/8" (16x86x1031)

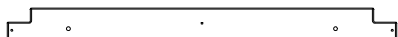

M10 | FLOOR BOARD - W4L13310
(x1) | 5/8"x3 1/4"x40 5/8" (16x81x1031)



H100086 | SCREW PFH
(x33) | 8x1 1/2



NOTE:
EVENLY SPACE FLOOR BOARDS

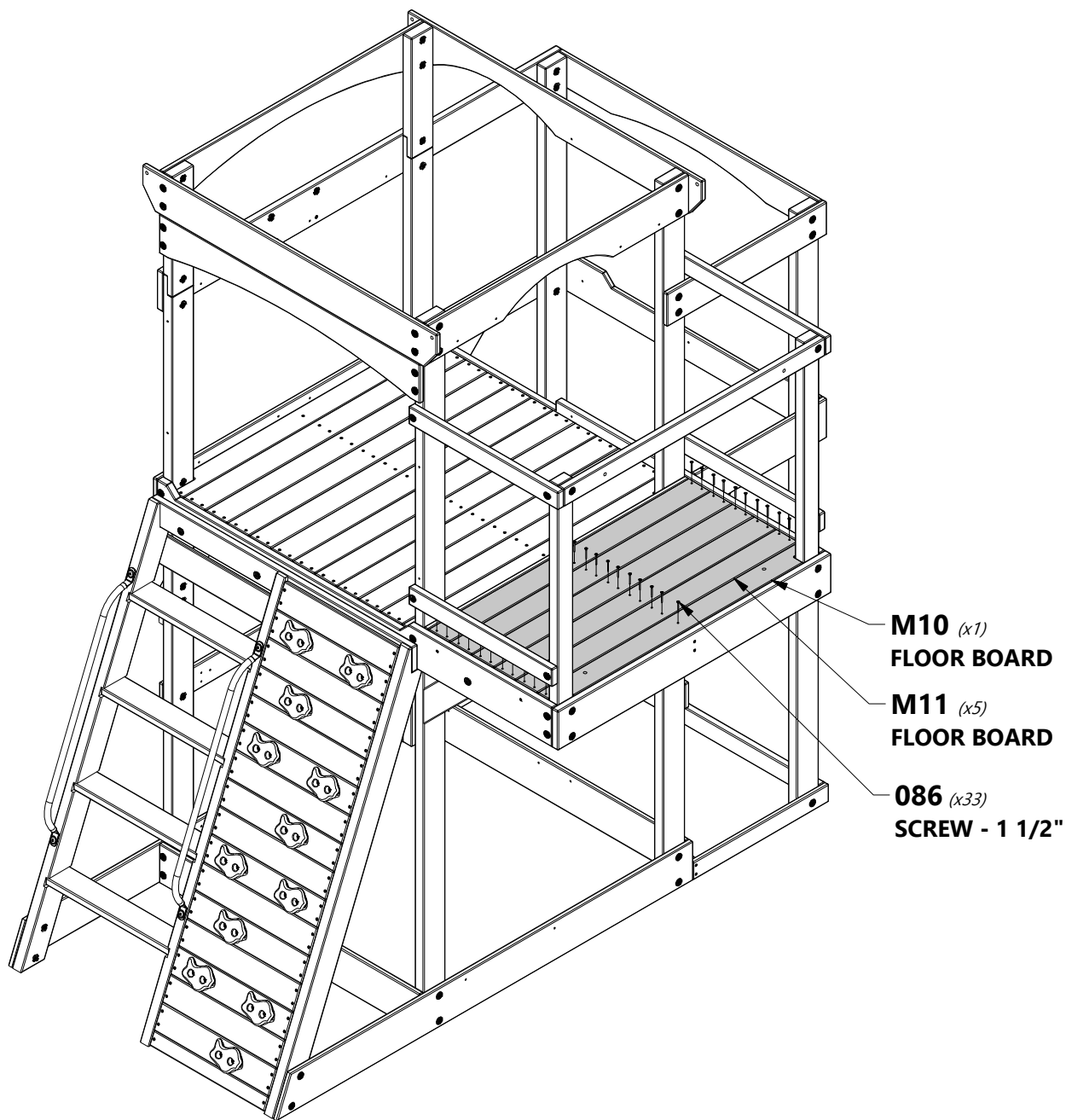

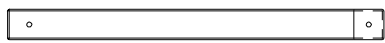

F1 | TUBE SLIDE MOUNT - W4L13179
(x2) | 1 3/8"x2 3/8"x29 3/8" (36x60x747)



A4M01047 | L BRACKET
(x2) | 2.5x38x55x55



H100468 | BOLT WH BLK
(x4) | 5/16x1



H100396 | BOLT WH BLK
(x2) | 5/16x1/2



H100192 | NUT BARREL
WH BLK
(x4) | 5/16x7/8



H100199 | WASHER LOCK
EXT BLK
(x4) | 12x19



H100198 | WASHER LOCK
EXT BLK
(x2) | 8x19



H100379 | T-NUT BLK
(x2) | 5/16

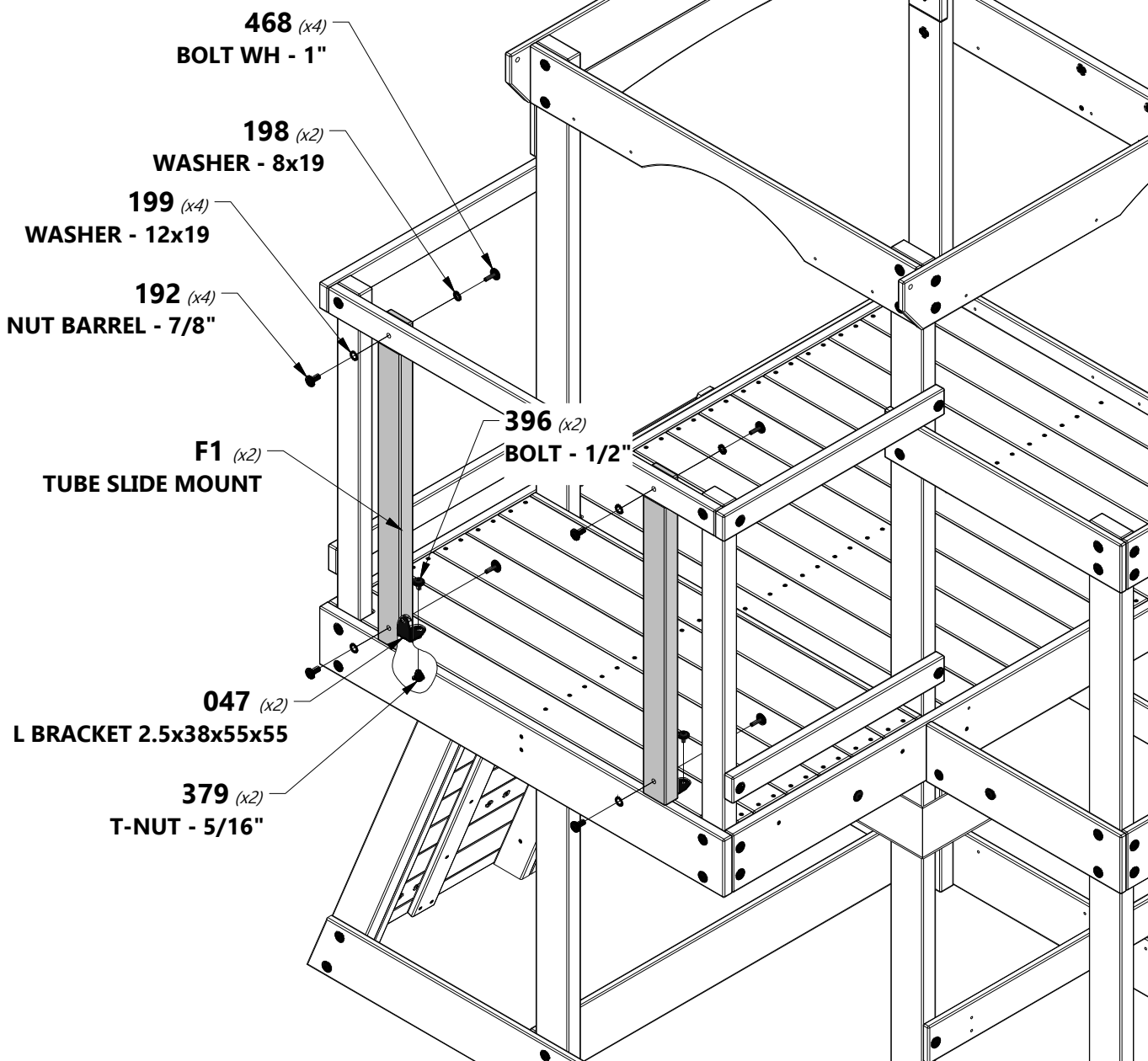

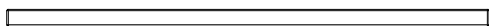

T1 | SUPPORT BOARD - W4L07599
(x1) | 1"x1 3/8"x37 5/8" (24x34x957)



T2 | SUPPORT BOARD - W4L07600
(x1) | 1"x1 3/8"x37 3/4" (24x34x959)



H100089 | SCREW PFH
(x3) | 8x1 3/4



H100387 | SCREW PFH BLK
(x3) | 8x1-1/4

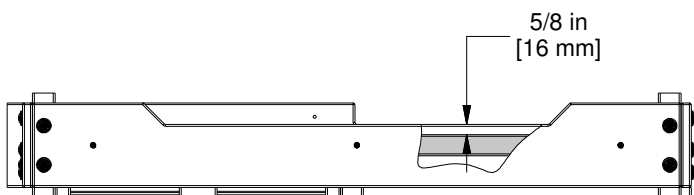
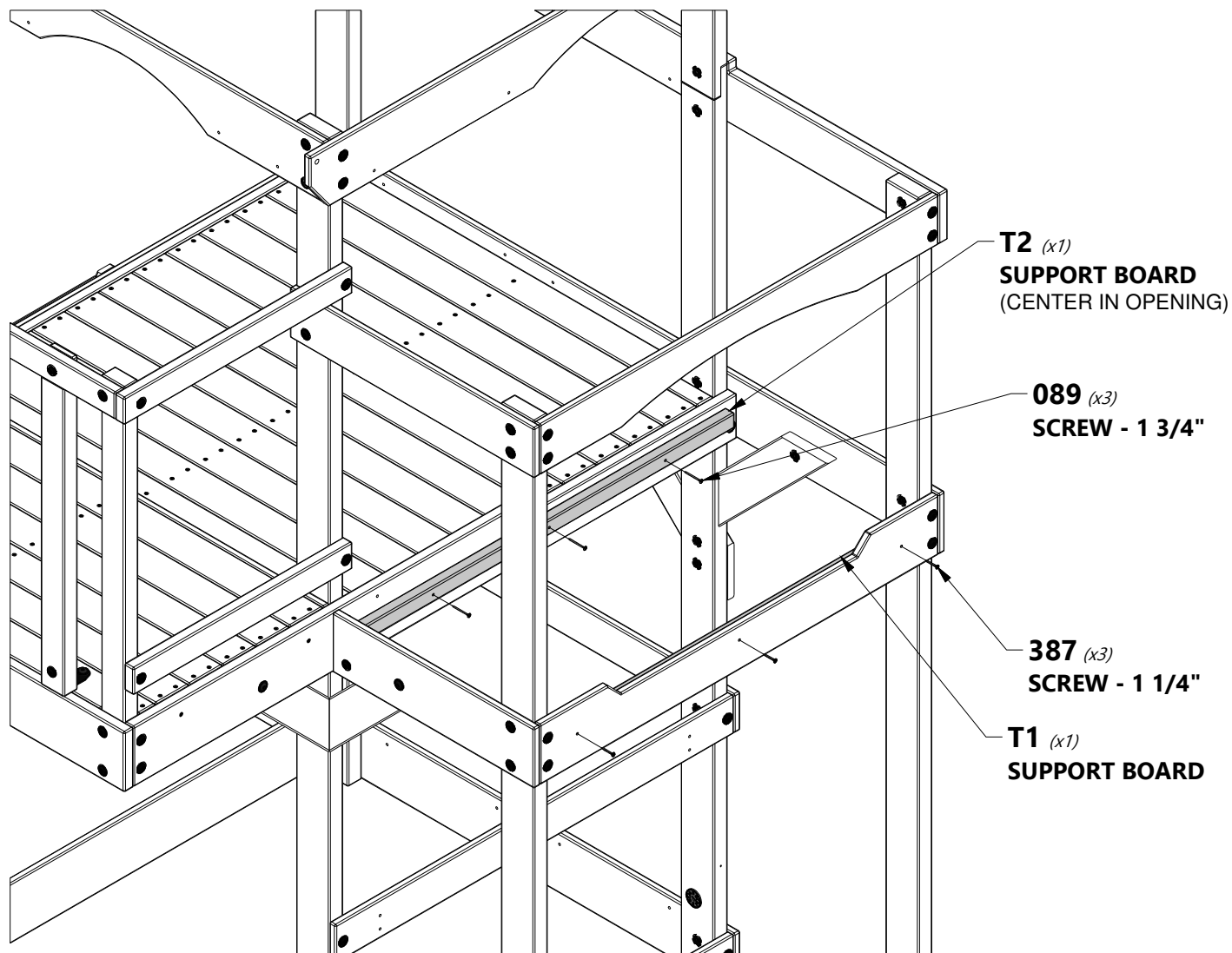

SIDE VIEW

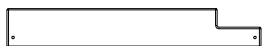

M7 | FLOOR BOARD - W4L13305
(x1) | 5/8"x3 1/8"x19 7/8" (16x78x504)



M9 | FLOOR BOARD - W4L13306
(x10) | 5/8"x3 3/8"x19 7/8" (16x86x504)



M8 | FLOOR BOARD - W4L13304
(x1) | 5/8"x3 3/8"x19 7/8" (16x86x504)



H100086 | SCREW PFH
(x44) | 8x1 1/2"



NOTE:

EVENLY SPACE FLOOR BOARDS

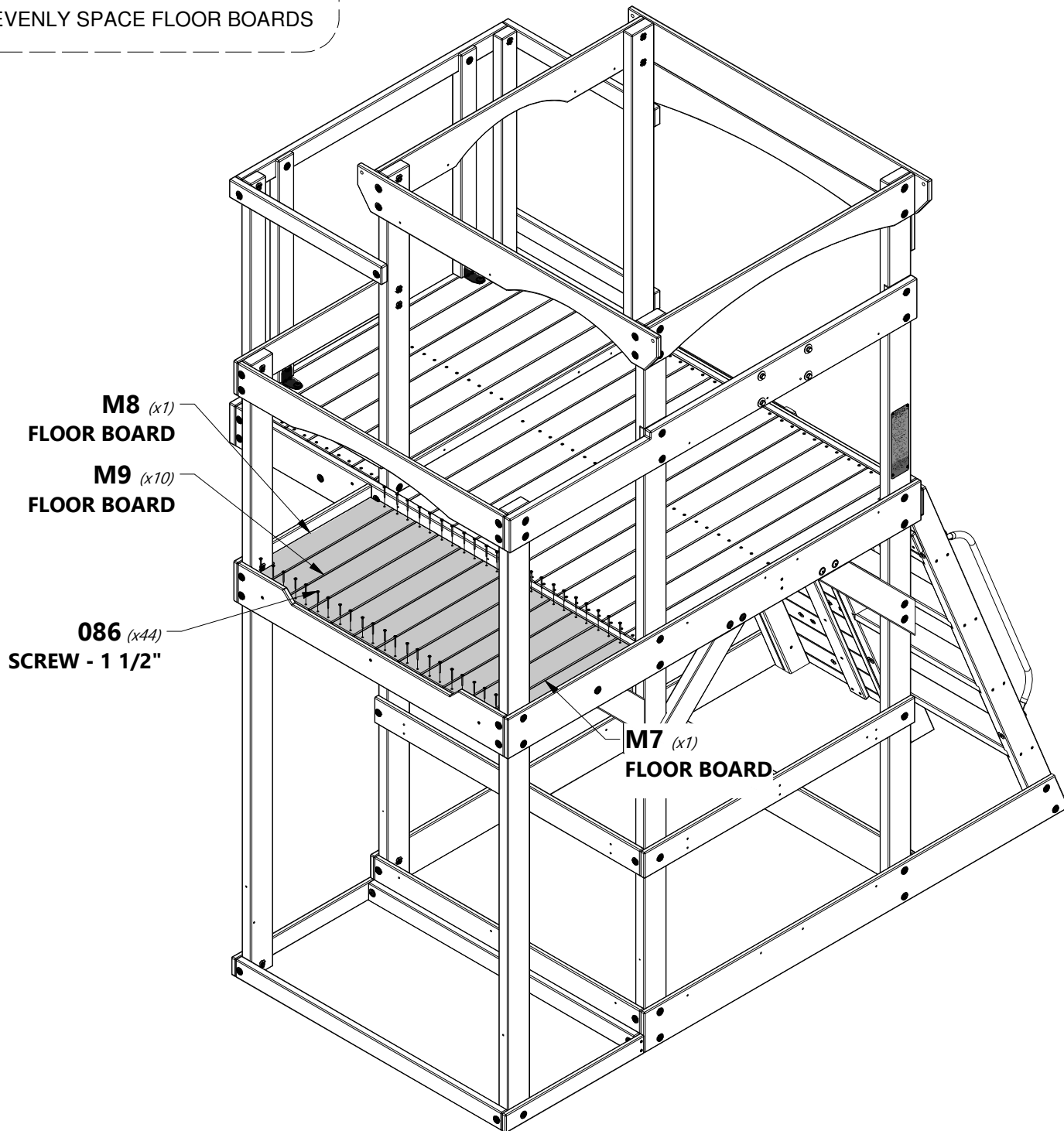



FORT ASSEMBLY

TOP

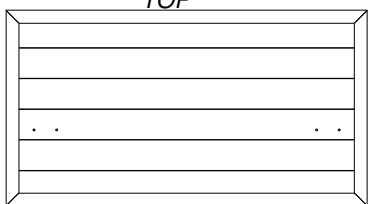

WP1 | WALL PANEL - W2A02840
(x1) 1"x20 3/8"x37 3/4" (24x517x956)

STEP 22



H100387 | SCREW PFH BLK
(x7) 8x1-1/4

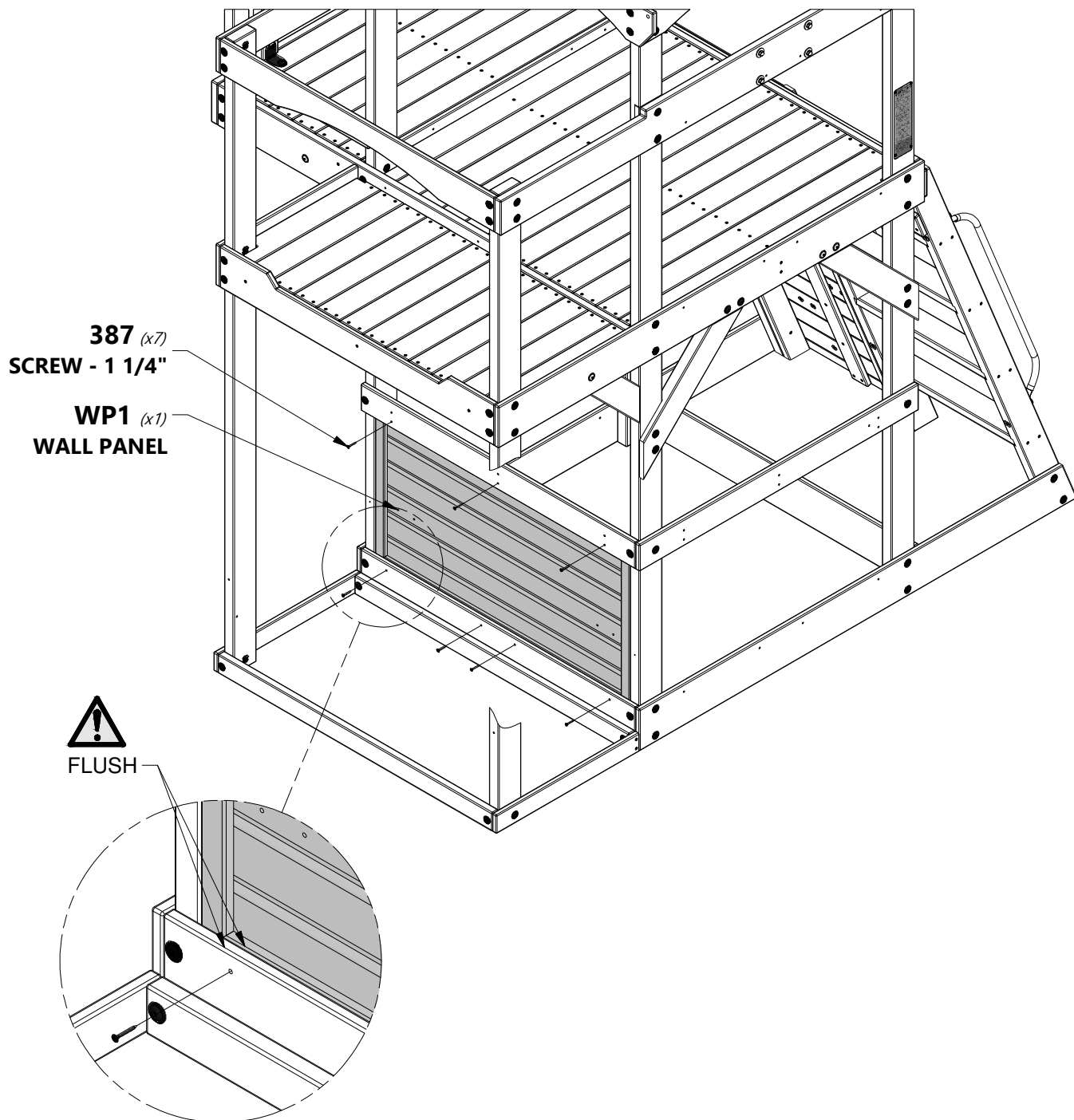

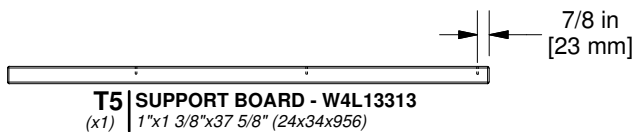

NOTE HOLE LOCATION FOR PROPER ASSEMBLY.

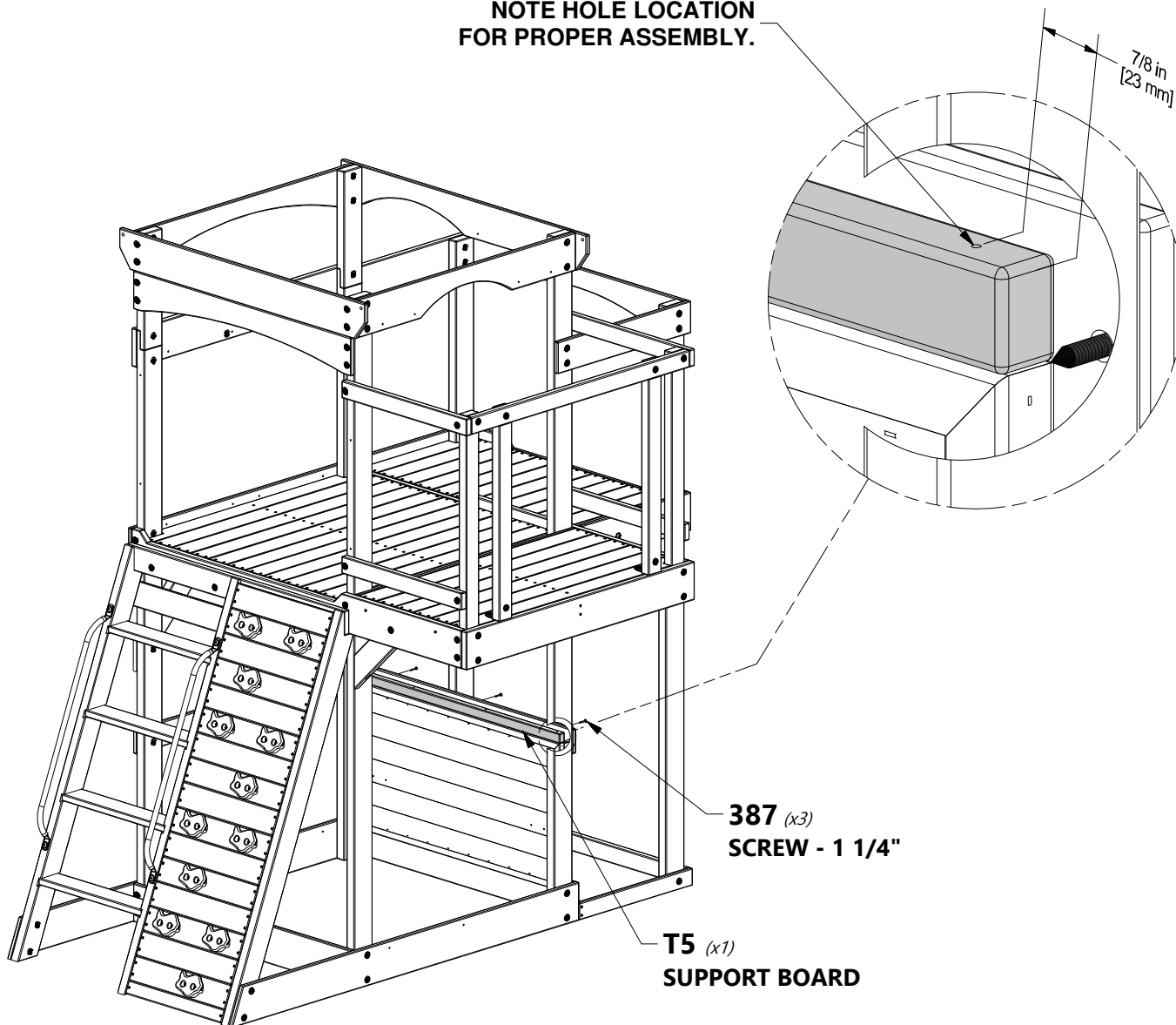



J6 | SUPPORT BLOCK - W4L13199
(x2) | 1"x2 3/8"x6 1/4" (24x60x160)



H100088 | SCREW PFH
(x4) | 8x1 1/8

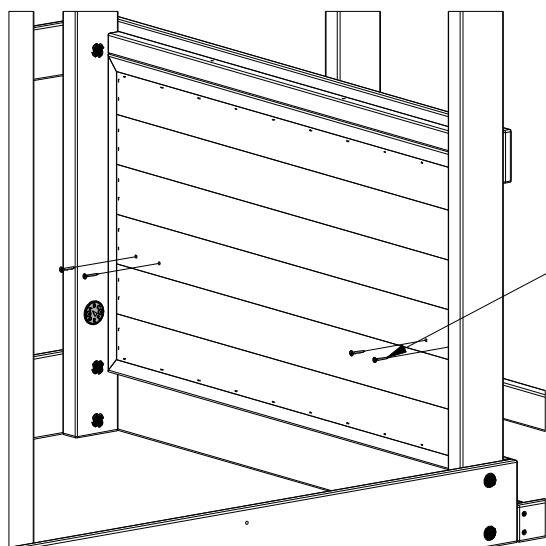
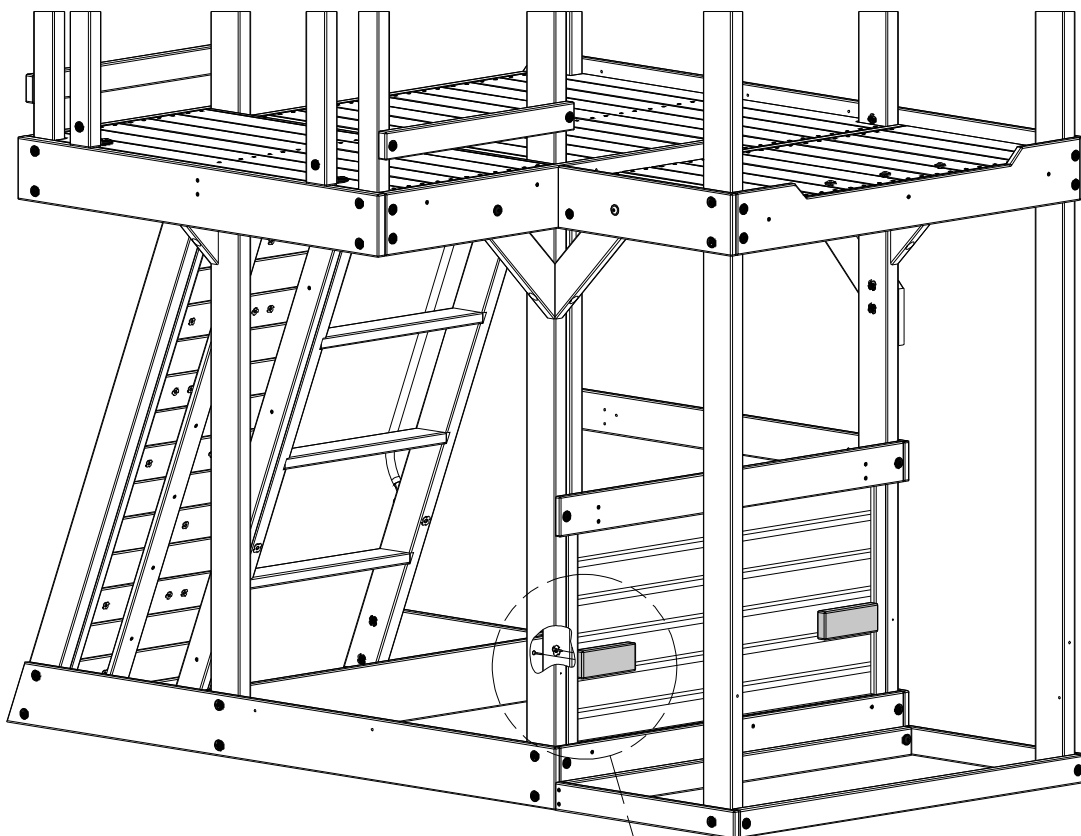

INSIDE VIEW

088 (x4)
SCREW - 1 1/8"

5 3/7 in
[137 mm]

J6 (x2)
SUPPORT BLOCK



K17 | FLOOR BOARD - W4L07596
(x2) | 5/8"x5 1/4"x21 1/8" (16x134x537)



M4 | FLOOR BOARD - W4L07597
(x9) | 5/8"x3 3/8"x21 1/8" (16x86x537)



H100086 | SCREW PFH
(x42) | 8x1 1/2



NOTE:
EVENLY SPACE FLOOR BOARDS

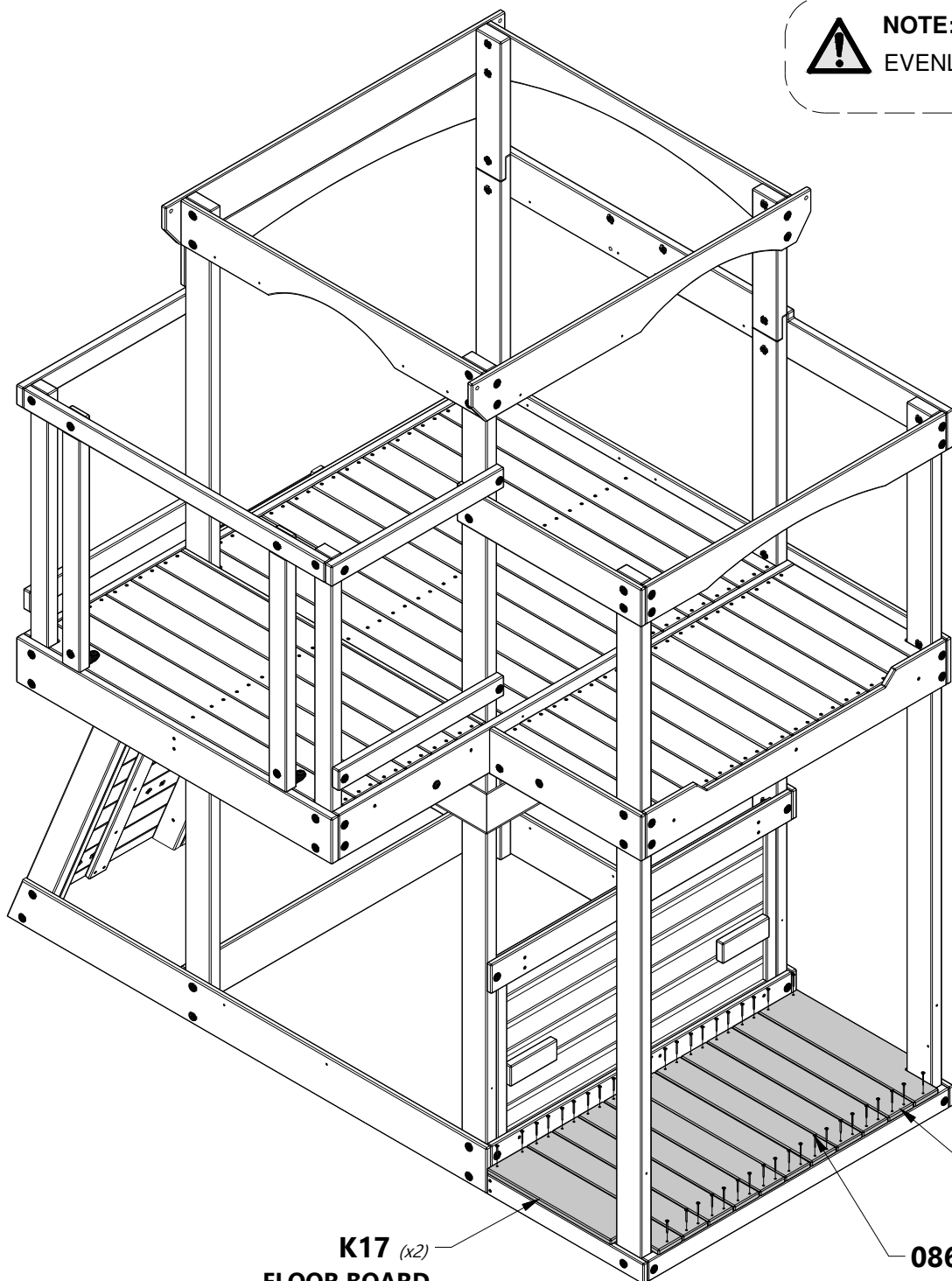

K17 (x2)
FLOOR BOARD

M4 (x9)
FLOOR BOARD

086 (x42)
SCREW - 1 1/2"



FORT ASSEMBLY

STEP 26



J3 | BENCH SUPPORT - W4L13196
(x2) | 1"x2 3/8"x9" (24x60x230)



J5 | SUPPORT BLOCK - W4L13198
(x2) | 1"x2 3/8"x2 7/8" (24x60x72)



J4 | ANGLE BRACE - W4L13197
(x2) | 1"x2 3/8"x10" (24x60x254)



H100378 | BOLT WH BLK
(x2) | 5/16x1 3/4



H100458 | LAG SCREW WH BLK
(x2) | 5/16x2



H100487 | LAG SCREW WH BLK
(x2) | 1/4x2



H100198 | WASHER LOCK
(x4) | EXT BLK
8x19



H100405 | WASHER LOCK
(x2) | EXT BLK
6x15



H100379 | T-NUT BLK
(x2) | 5/16



H100382 | SCREW PFH BLK
(x4) | 8x1 3/4

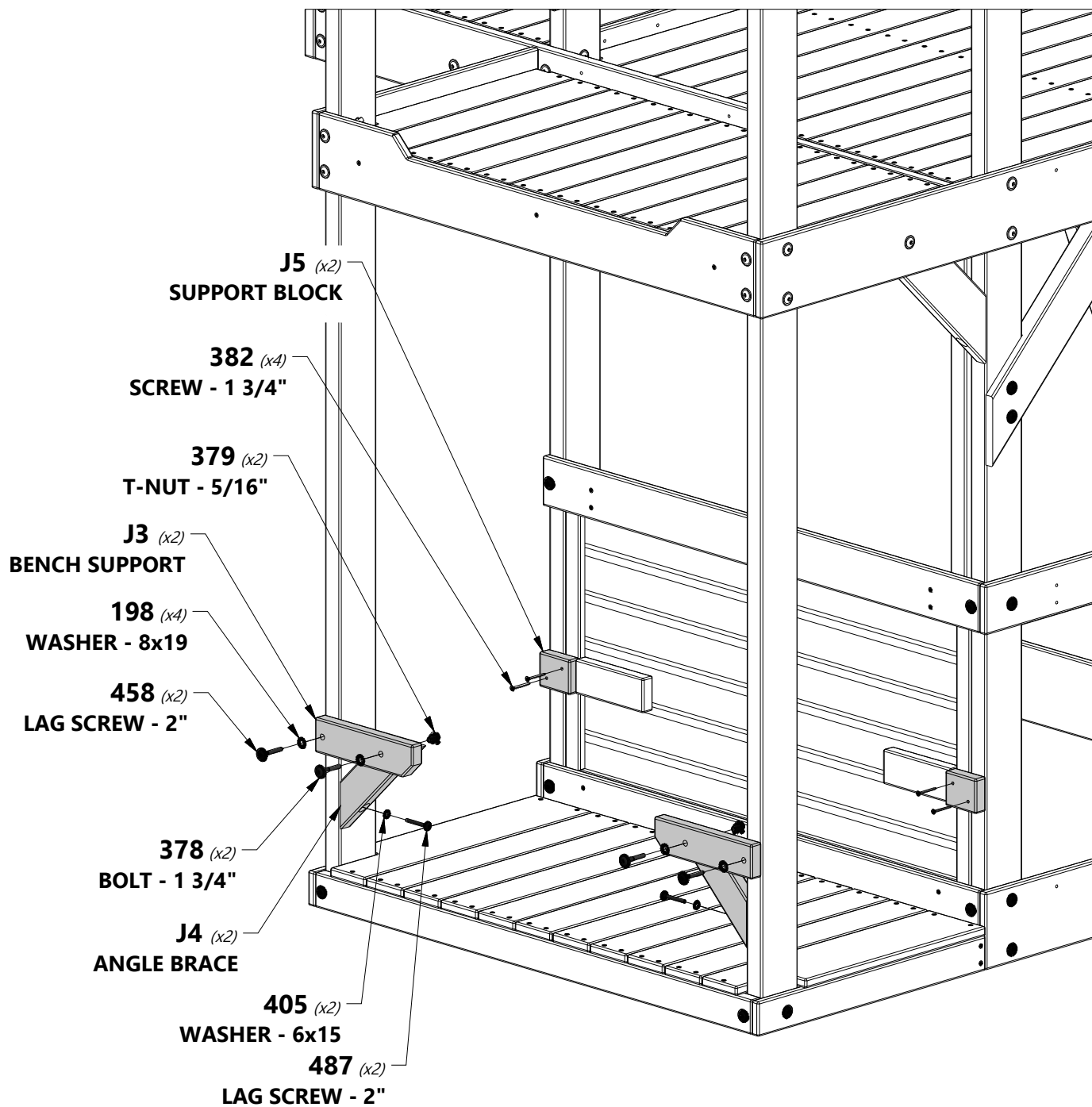



M2 | BENCH BOARD - W4L07591
(x2) | 5/8"x3 3/8"x23" (16x86x583)



N3 | BENCH BOARD - W4L07592
(x2) | 5/8"x2 3/8"x23" (16x60x583)



M3 | BENCH BOARD - W4L07593
(x2) | 5/8"x3 3/8"x23" (16x86x583)



H100086 | SCREW PFH
(x22) | 8x1 1/2

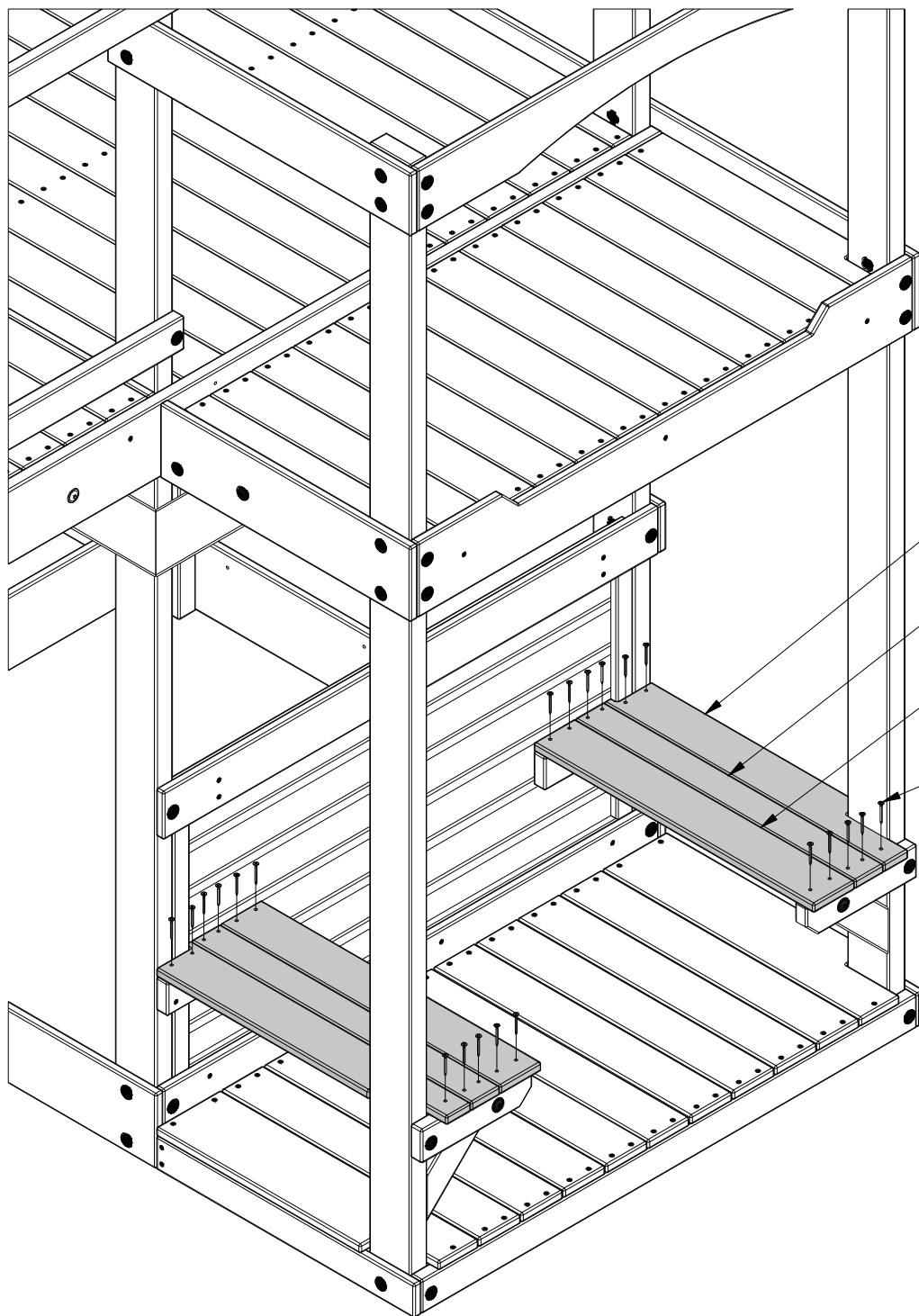

- M2** (x2)
BENCH BOARD
- N3** (x2)
BENCH BOARD
- M3** (x2)
BENCH BOARD
- 086** (x22)
SCREW - 1 1/2"

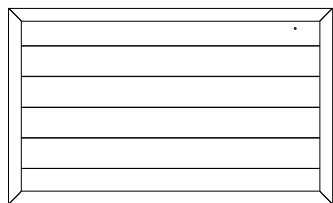

WP2 | WALL PANEL - W2A02841
(x1) | 1"x20 3/8"x37 3/4" (24x517x858)



H100387 | SCREW PFH BLK
(x7) | 8x1-1/4

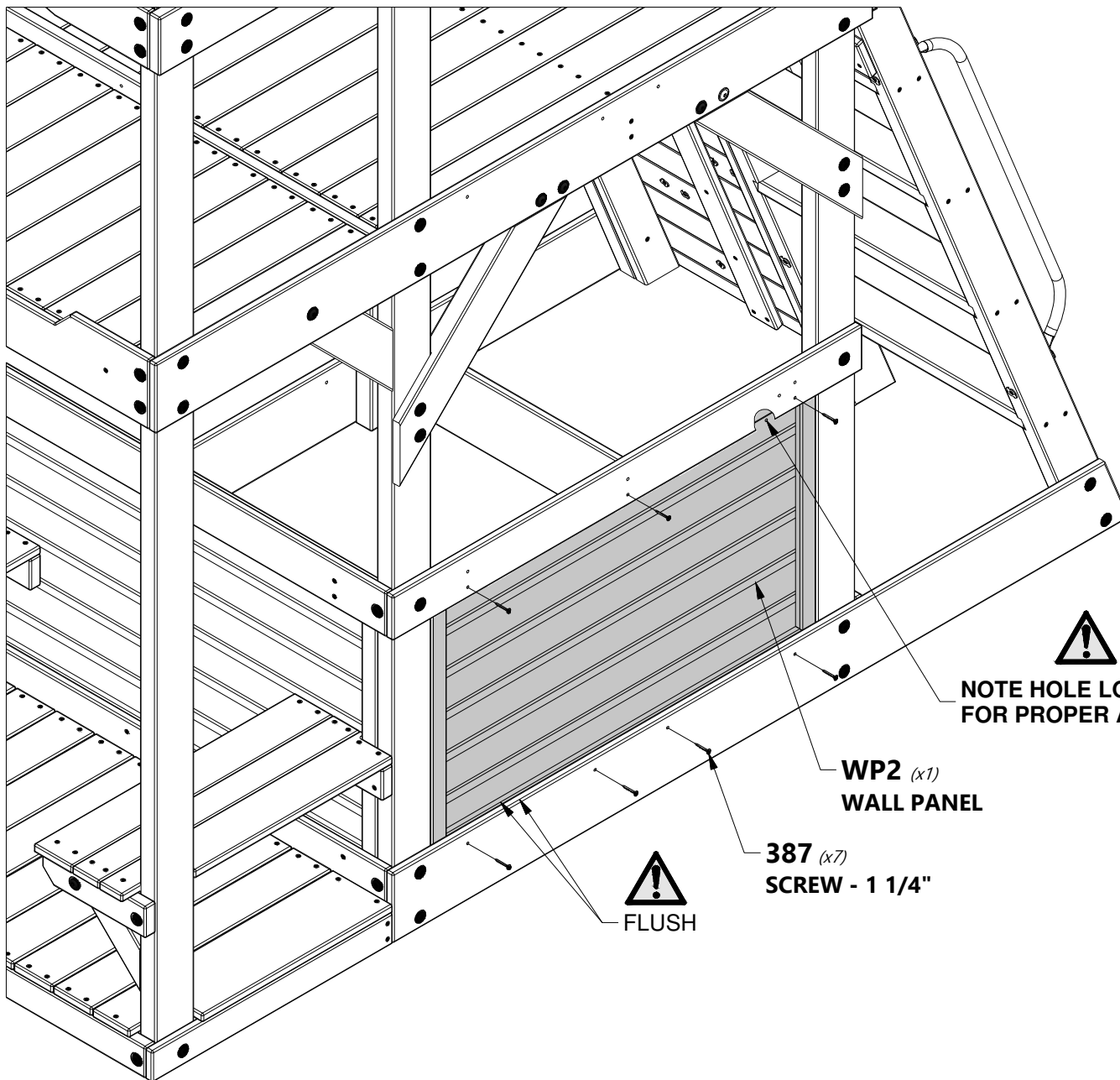



T4 | SUPPORT BOARD - W4L13312
(x1) | 1" x 1 3/8" x 33 3/4" (24x34x858)



H100387 | SCREW PFH BLK
(x3) | 8x1-1/4

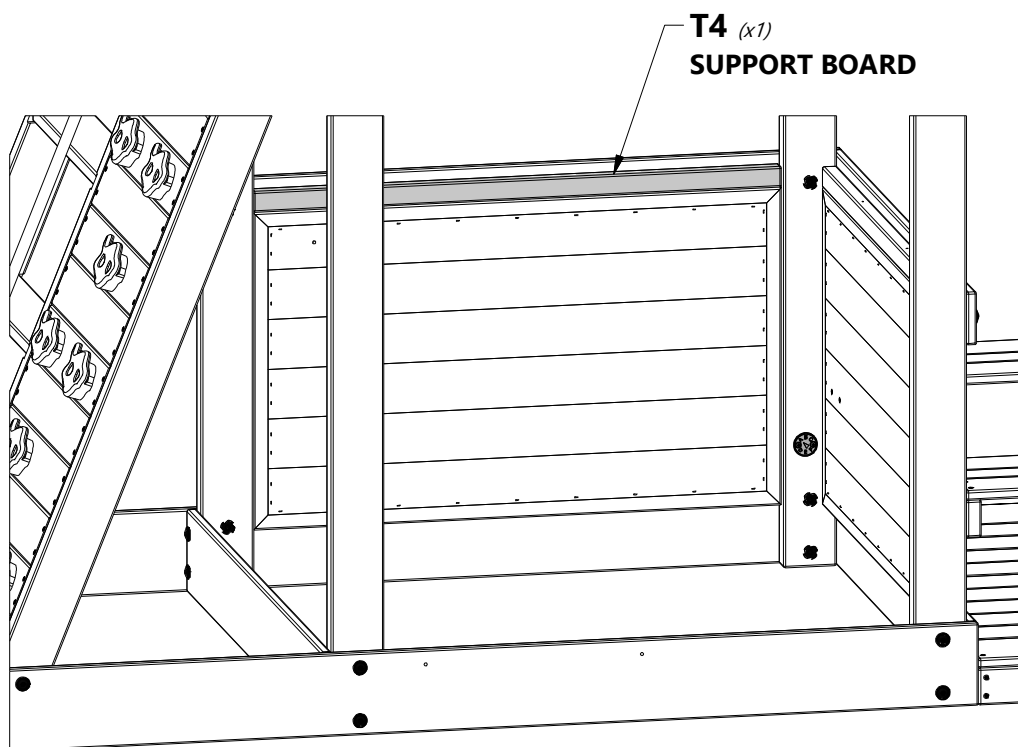

INSIDE VIEW

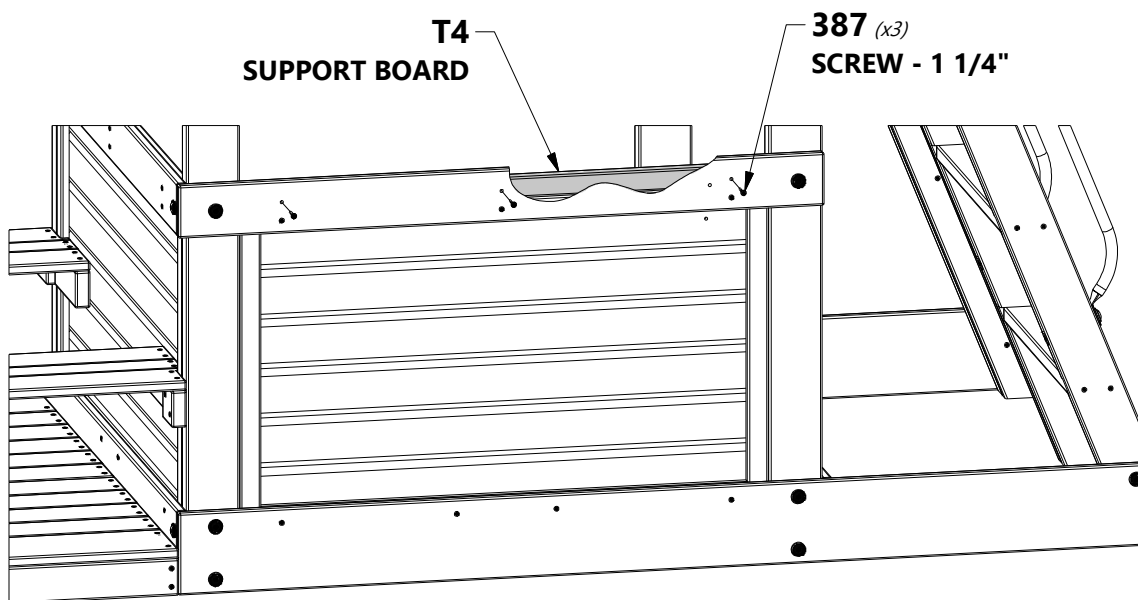

OUTSIDE VIEW

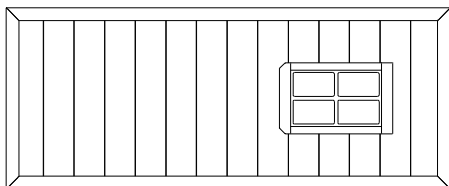

WP9 | WALL PANEL - W2A02090
(x1) | 1"x16 7/8"x46 1/2" (24x479x1176)



H100387 | SCREW PFH BLK
(x4) | 8x1-1/4

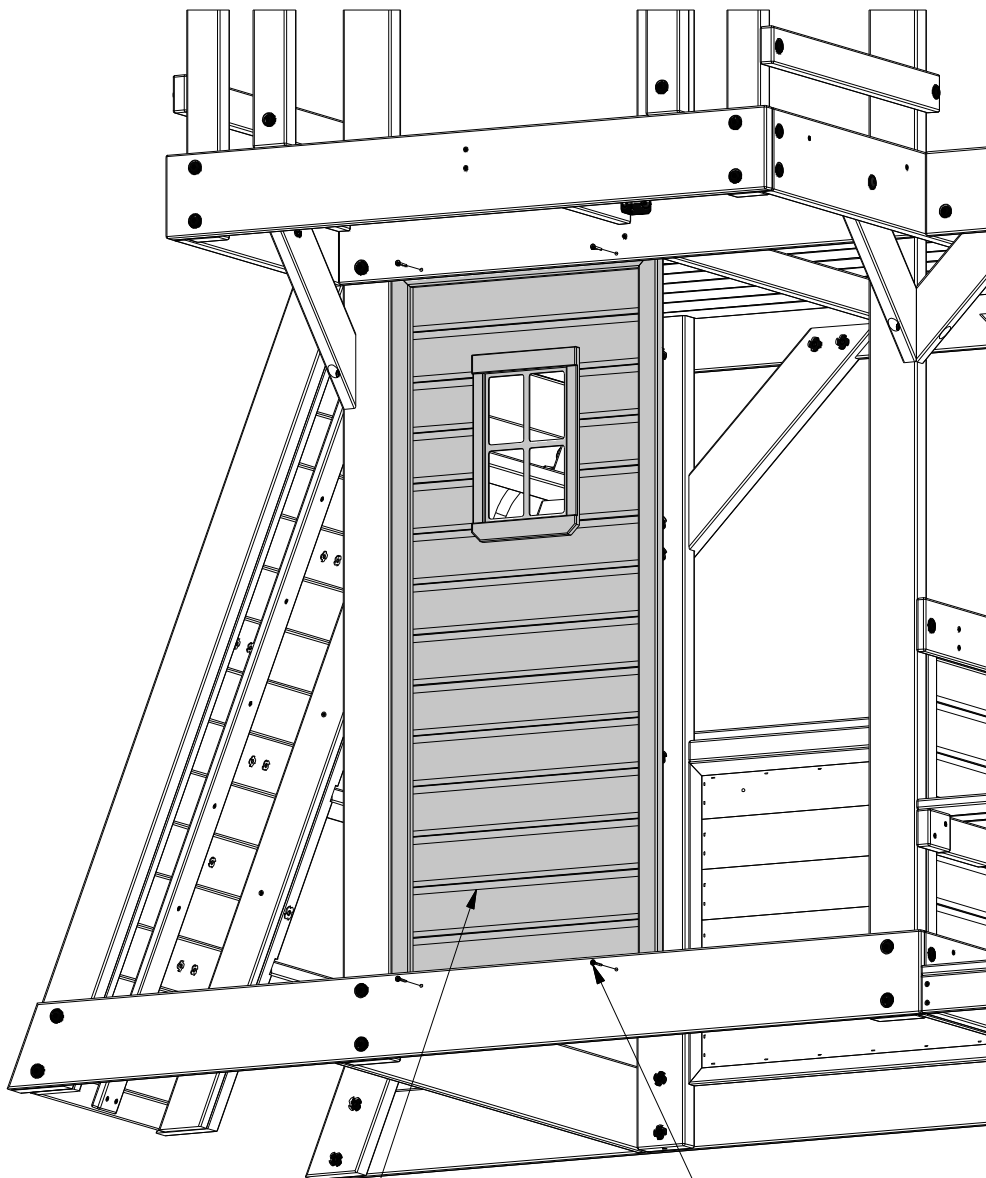

WP9 (x1)
WALL PANEL

387 (x4)
SCREW - 1 1/4"



Q1 | COUNTER TOP SUPPORT - W4L13319
(x1) | 1"x4 3/8"x9 1/2" (24x112x240)



J10 | SUPPORT BOARD - W4L13321
(x1) | 1"x2 3/8"x2 3/8" (24x60x60)



H100821 | SCREW PFH BLK
(x1) | 8x2-3/4



H100089 | SCREW PFH
(x2) | 8x1 3/4



H100086 | SCREW PFH
(x1) | 8x1 1/2

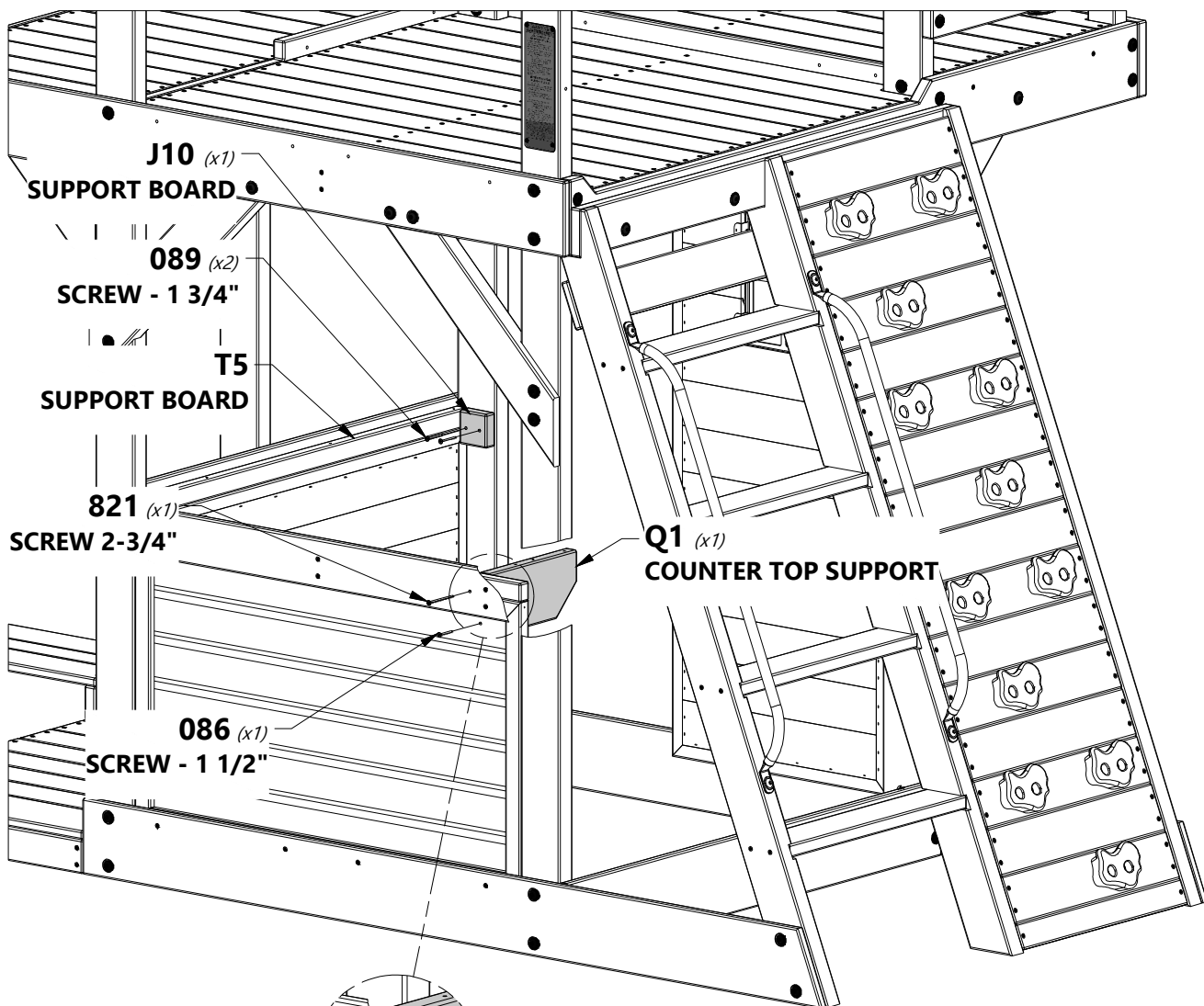

J10 (x1)
SUPPORT BOARD

089 (x2)
SCREW - 1 3/4"

T5
SUPPORT BOARD

821 (x1)
SCREW 2-3/4"

Q1 (x1)
COUNTER TOP SUPPORT

086 (x1)
SCREW - 1 1/2"

T4
SUPPORT BOARD



NOTE:
USING HOLE AS A GUIDE,
DRILL A 3/16" PILOT HOLE
THRU T4 BOARD.

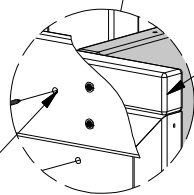

NOTE:
ALIGN PILOT HOLES IN Q1 BOARD
TO PILOT HOLES IN WALL PANEL.
FLUSH TOP OF J10 WITH TOP OF T5.

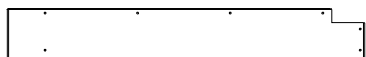

K16 | COUNTER TOP - W4L13316
(x1) | 5/8"x5 1/4"x37 1/4" (16x134x946)

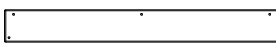

M6 | COUNTER TOP BOARD - W4L13318
(x1) | 5/8"x3 3/8"x28 5/8" (16x86x726)



K18 | COUNTER TOP - W4L13317
(x1) | 5/8"x5 1/4"x37 1/4" (16x134x946)



N6 | CLEAT - W4L13320
(x1) | 5/8"x2 3/8"x5 7/8" (16x60x150)



H100086 | SCREW PFH
(x15) | 8x1 1/2"



H100088 | SCREW PFH
(x4) | 8x1 1/8"

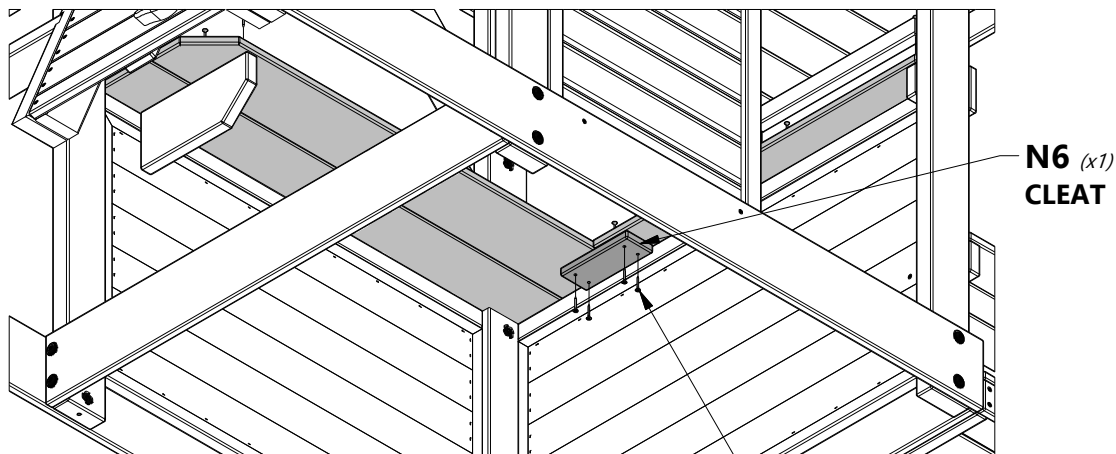
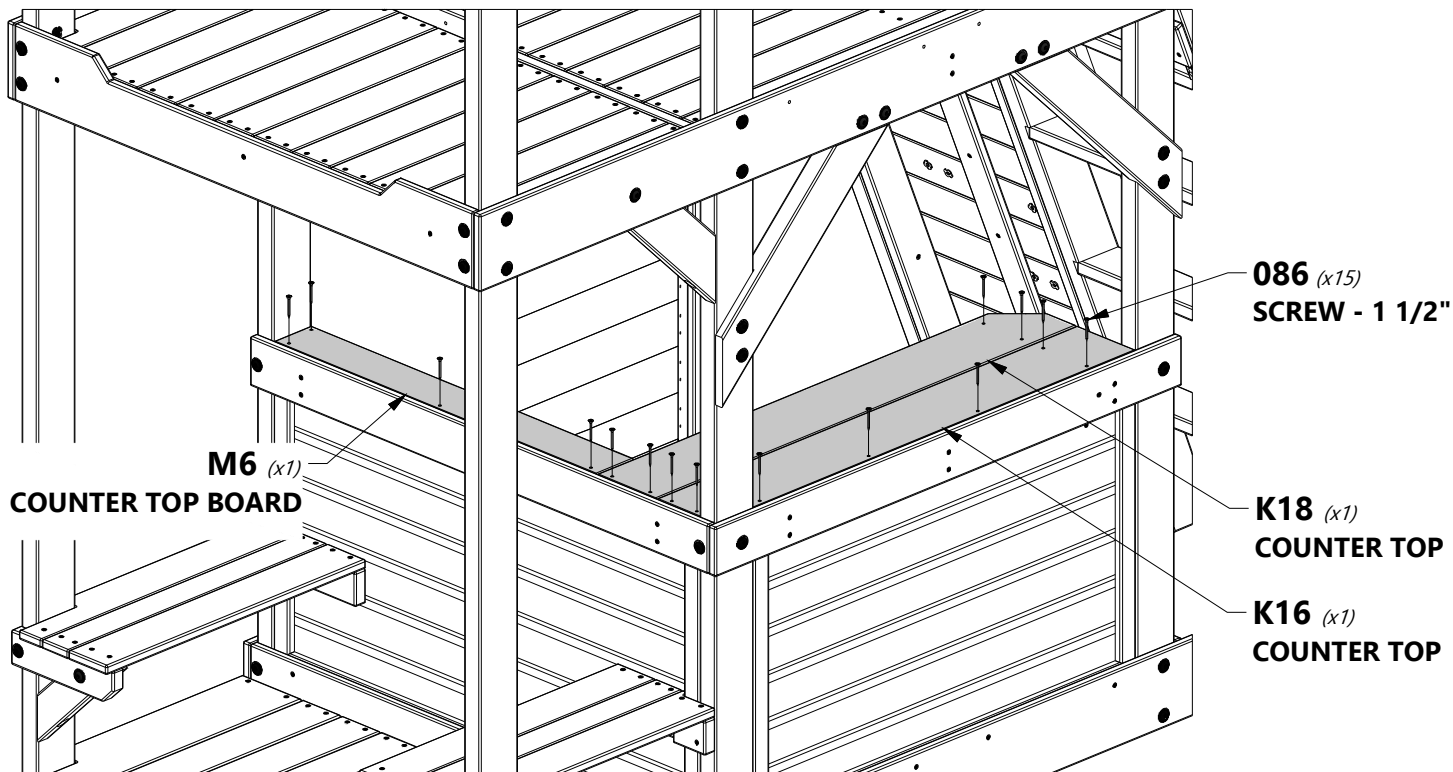

BOTTOM VIEW

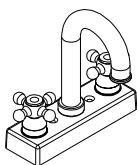

A6P00024 | FAUCET KIT
(x1)

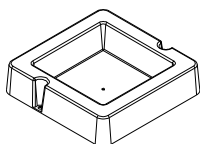

A6P00032 | SURFACE MOUNT BASIN
(x1)



H100086 | SCREW PFH
(x2) | 8x1 1/2



H100128 | SCREW PWH
(x2) | 8x5/8

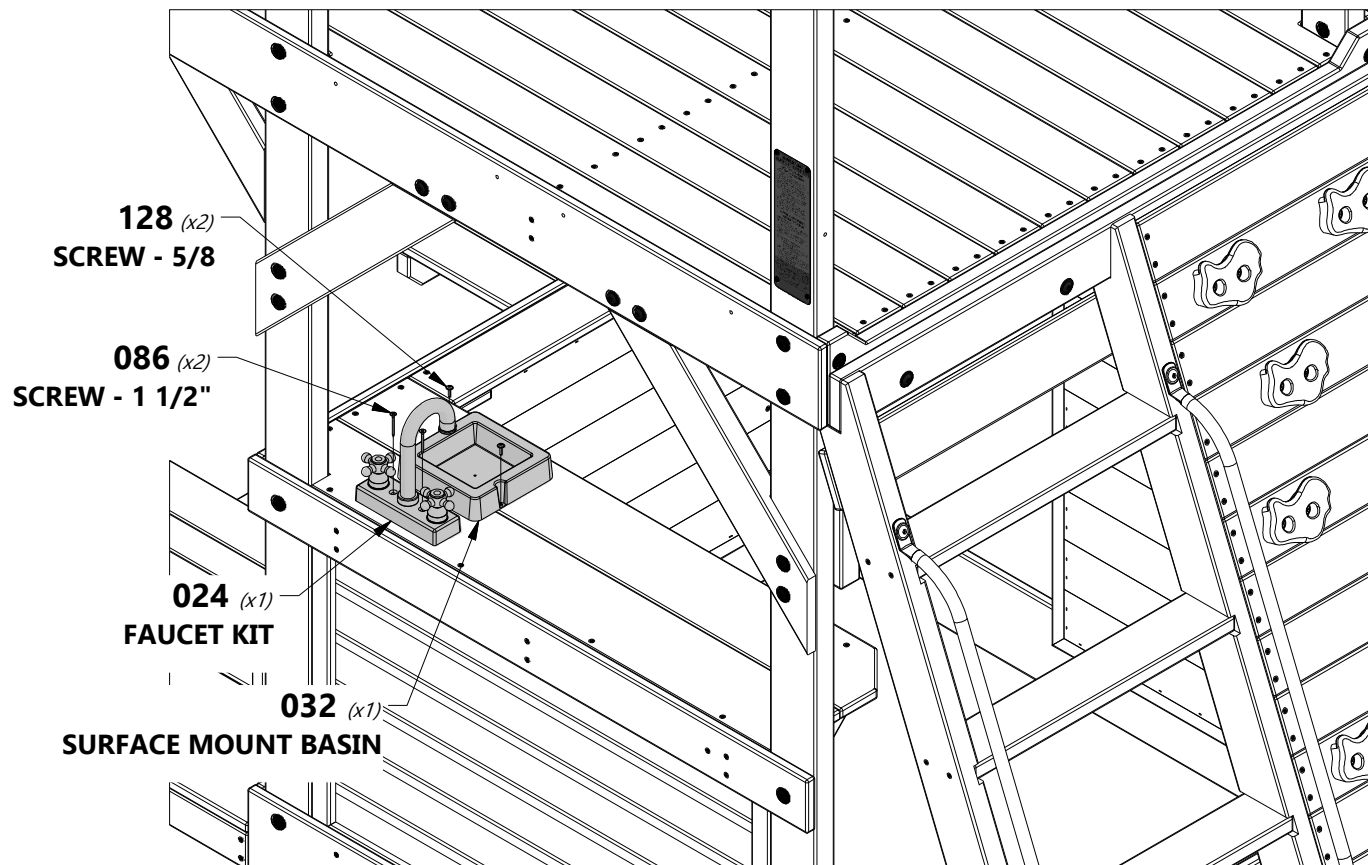

TIP:
APPROXIMATE LOCATION
FOR SINK & FAUCET

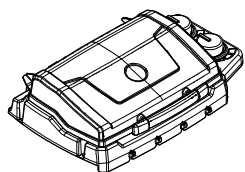

A6P00282 | BBQ GRILL
(x1)



H100128 | SCREW PWH
(x4) | 8x5/8

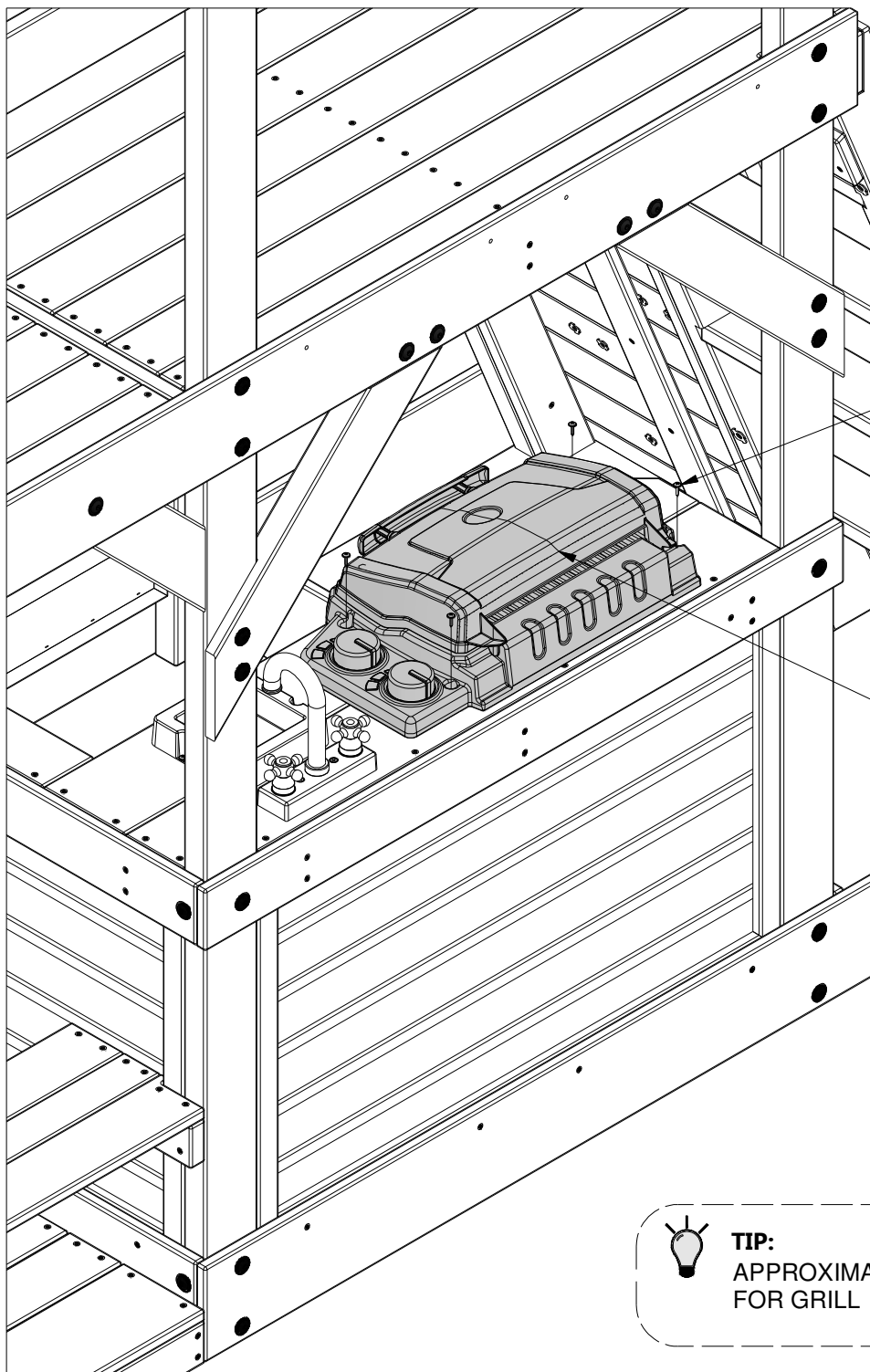

128 *(x4)*
SCREW - 5/8

282 *(x1)*
BBQ GRILL



TIP:
APPROXIMATE LOCATION
FOR GRILL

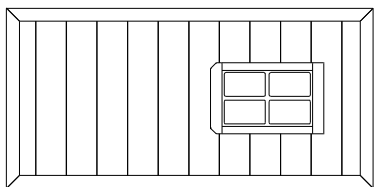

WP7 | WALL PANEL - W2A02088
(x1) 1"x16 7/8"x46 1/2" (24x476x971)



H100387 | SCREW PFH BLK
(x4) 8x1-1/4

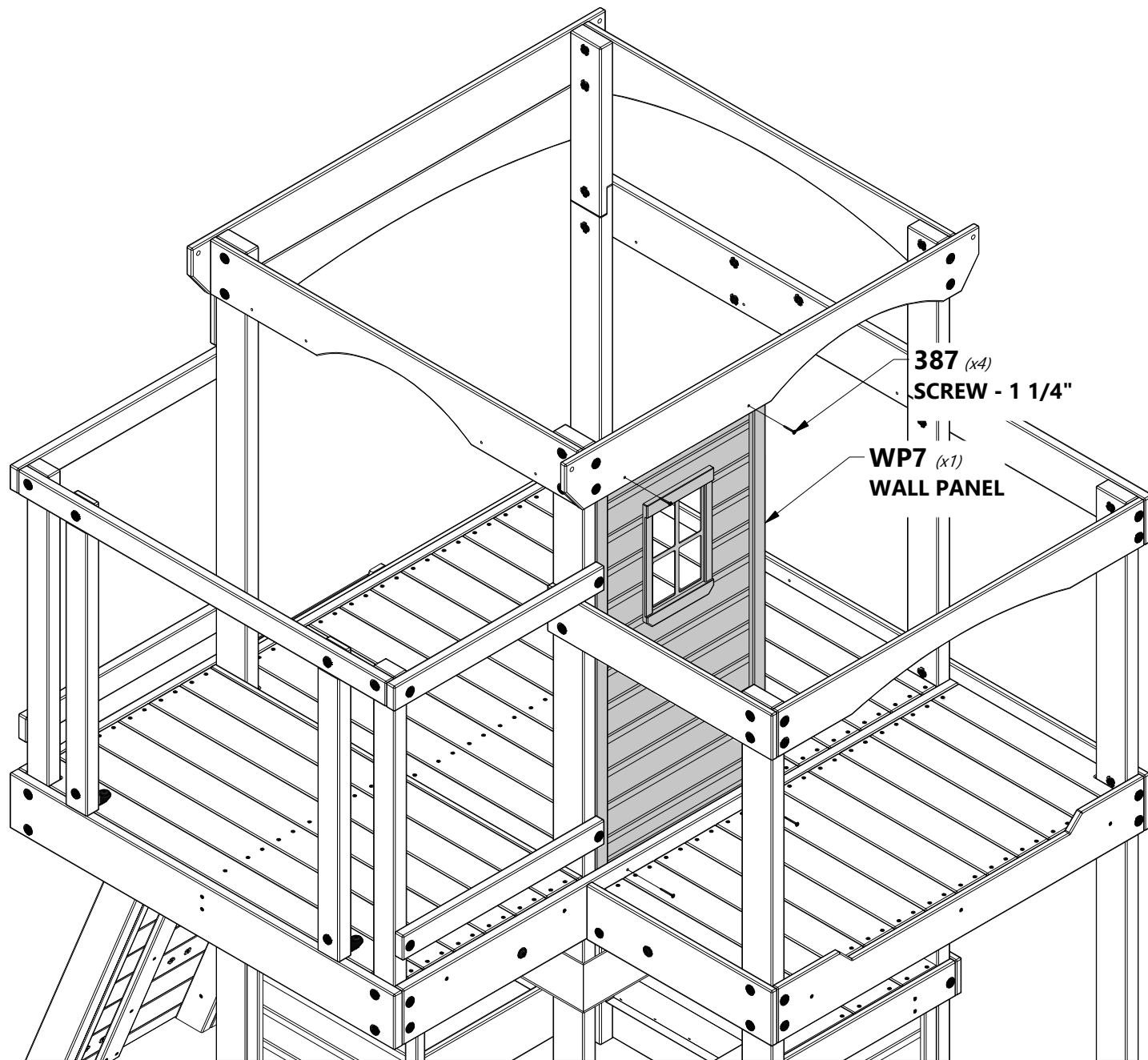

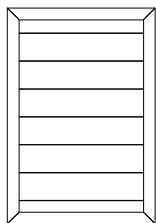

WP3 | WALL PANEL - W2A02849
(x2) | 1"x16 7/8"x24 5/8" (24x430x627)



H100200 | SCREW PFH BLK
(x4) | 8x1 1/2



H100387 | SCREW PFH BLK
(x4) | 8x1-1/4

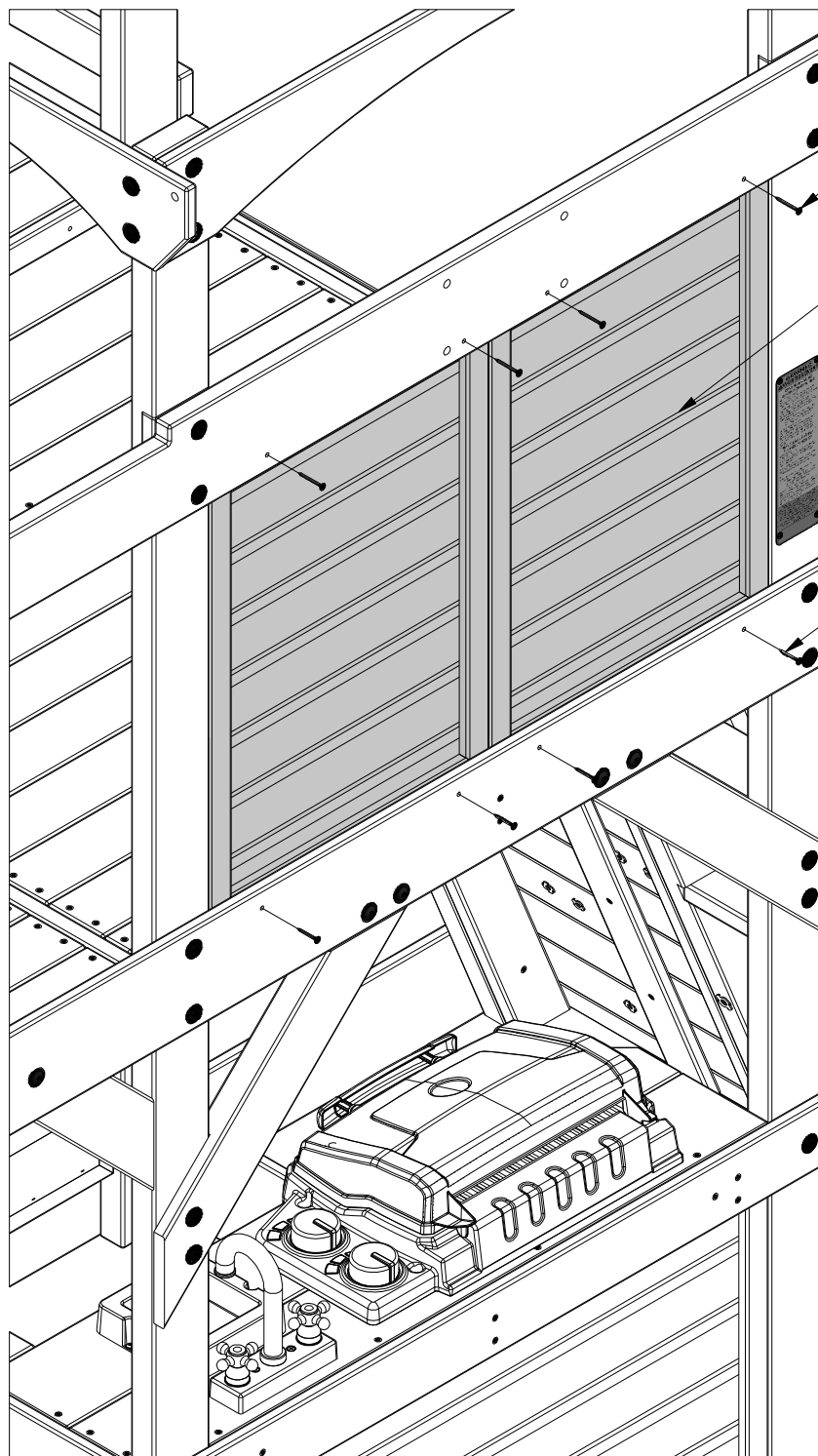

200 (x4)
SCREW - 1 1/2"

WP3 (x2)
WALL PANEL

387 (x4)
SCREW - 1 1/4"

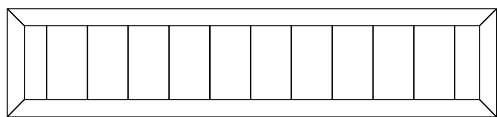

WP8 | WALL PANEL - W2A02089
(x2) 1"x18 7/8"x11 3/4" (24x214x971)



H100387 | SCREW PFH BLK
(x8) 8x1-1/4

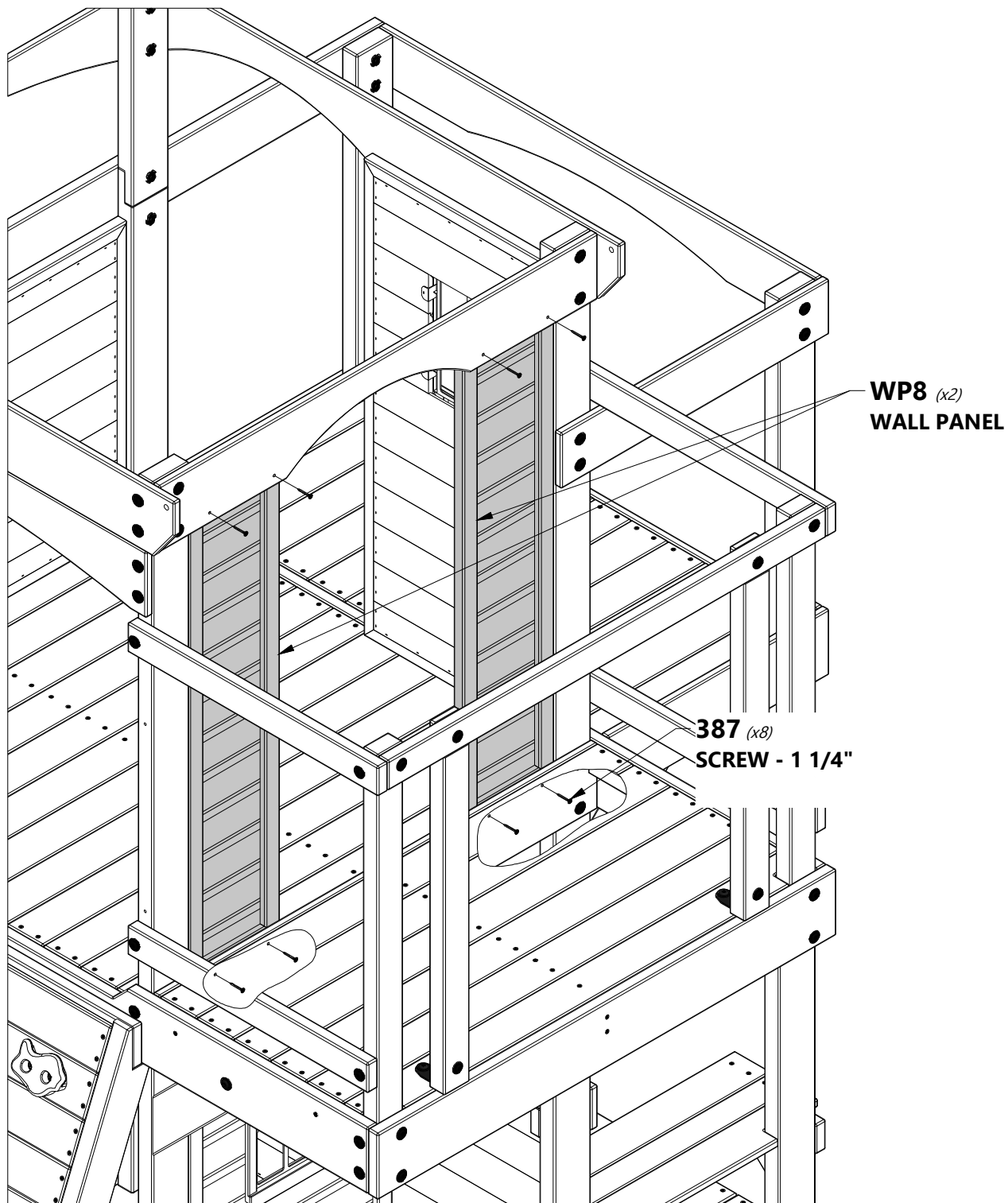

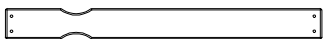

N2 PICKET - W4L07612
(x8) | 5/8"x2 3/8"x24 3/4" (16x60x628)



H100088 SCREW PFH
(x32) | 8x1 1/8

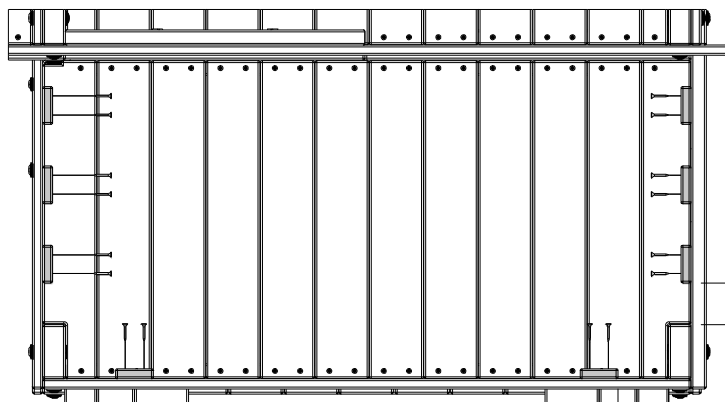
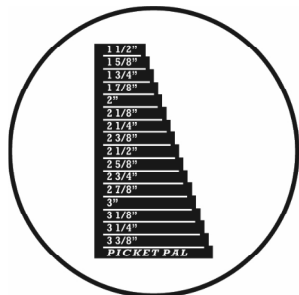

TOP VIEW

2 5/8 in
[66 mm]

3 1/8 in
[80 mm]

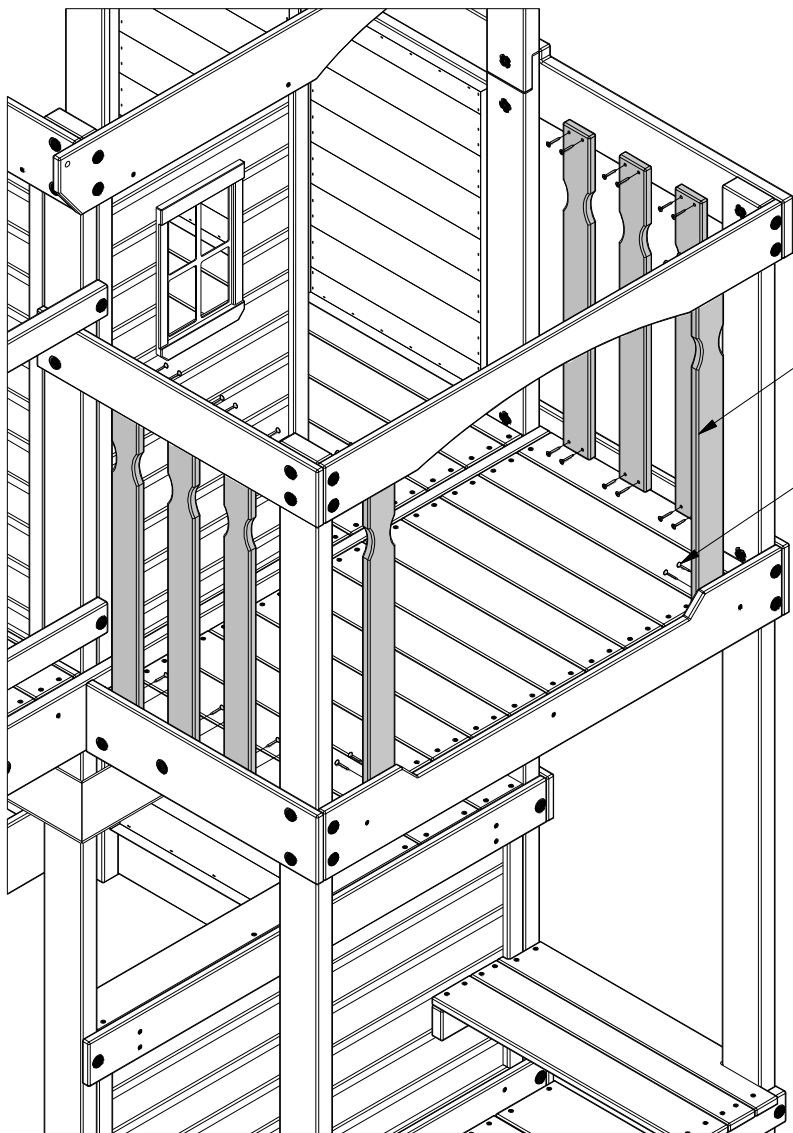

N2 (x8)
PICKET

088 (x32)
SCREW - 1 1/8"

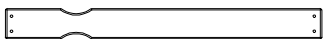

N2 | PICKET - W4L07612
(x6) | 5/8"x2 3/8"x24 3/4" (16x60x628)



H100088 | SCREW PFH
(x24) | 8x1 1/8

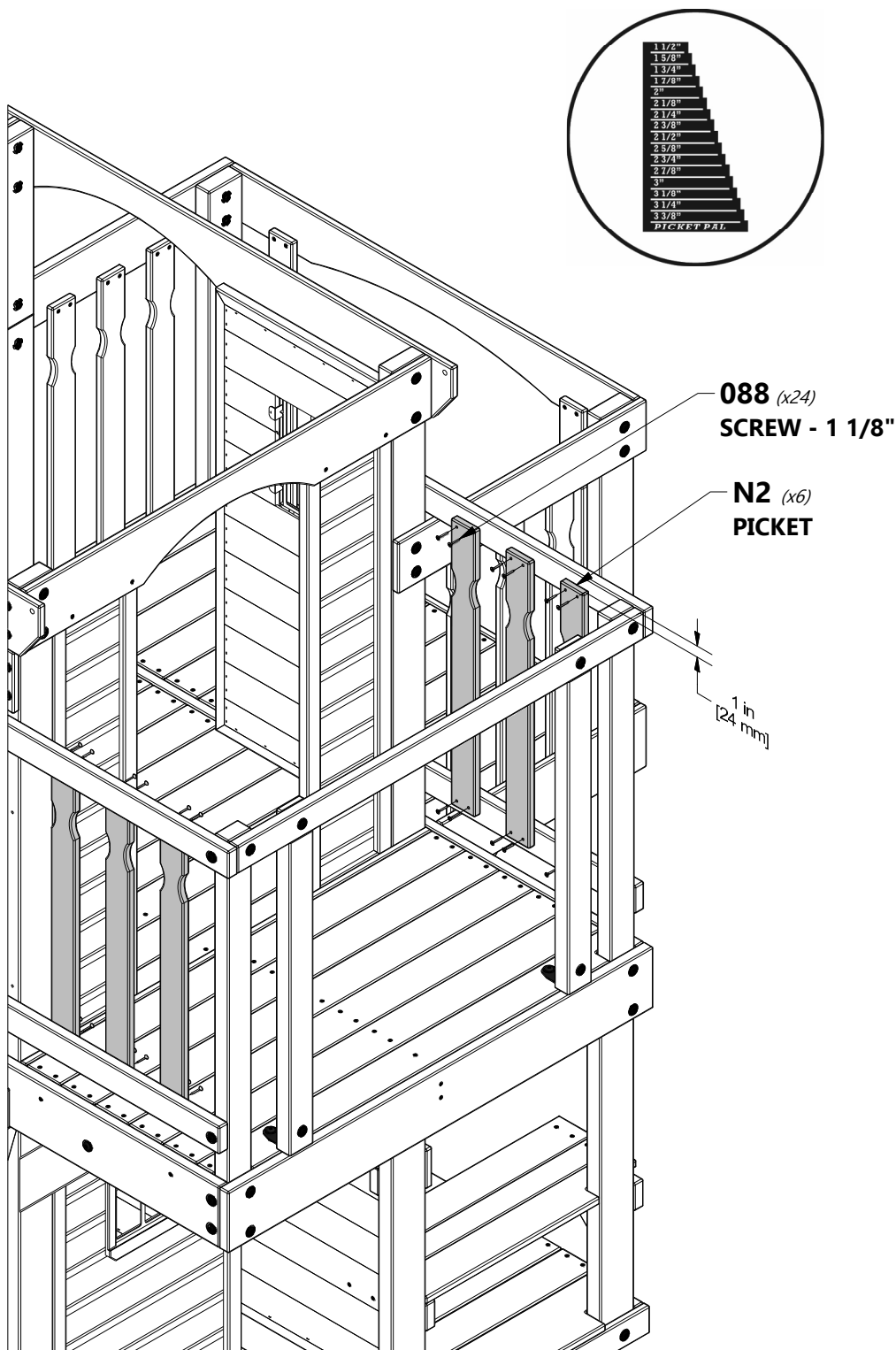

TOP VIEW

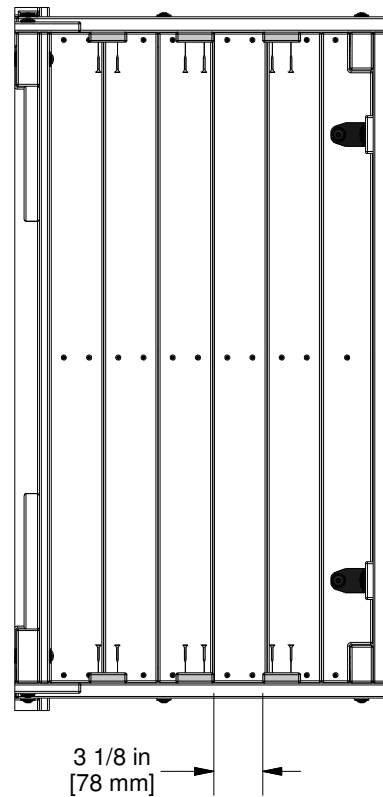

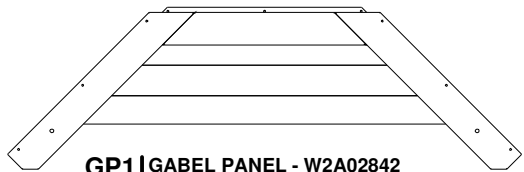

GP1 | GABLE PANEL - W2A02842
(x1) | 1 1/8"x16 3/8"x53 1/2" (27x414x1359)

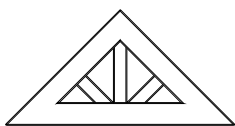

A100322 | PLASTIC
(x1) | SUNBURST



H100459 | BOLT WH BLK
(x2) | 5/16x1 1/4



H100785 | SCREW PWH
(x3) | 8x1



H100198 | WASHER LOCK
(x2) | EXT BLK
8x19



H100379 | T-NUT BLK
(x2) | 5/16

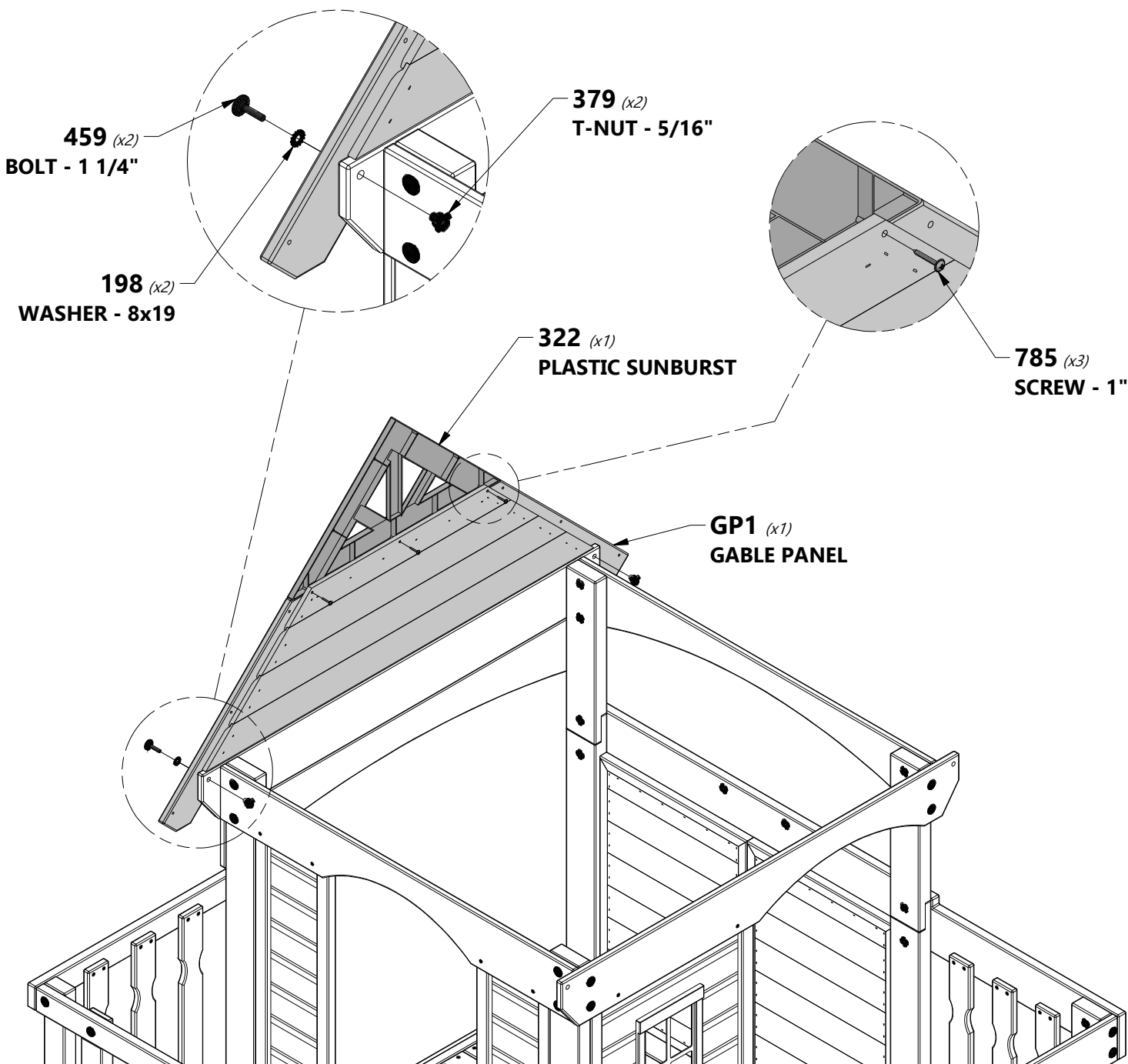

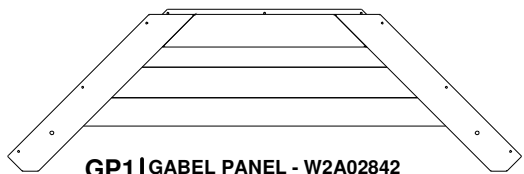

GP1 | GABLE PANEL - W2A02842
(x1) | 1 1/8"x16 3/8"x53 1/2" (27x414x1359)

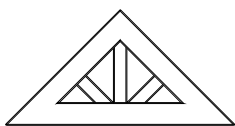

A100322 | PLASTIC
(x1) | SUNBURST



H100459 | BOLT WH BLK
(x2) | 5/16x1 1/4



H100785 | SCREW PWH
(x3) | 8x1



H100198 | WASHER LOCK
(x2) | EXT BLK
8x19



H100379 | T-NUT BLK
(x2) | 5/16

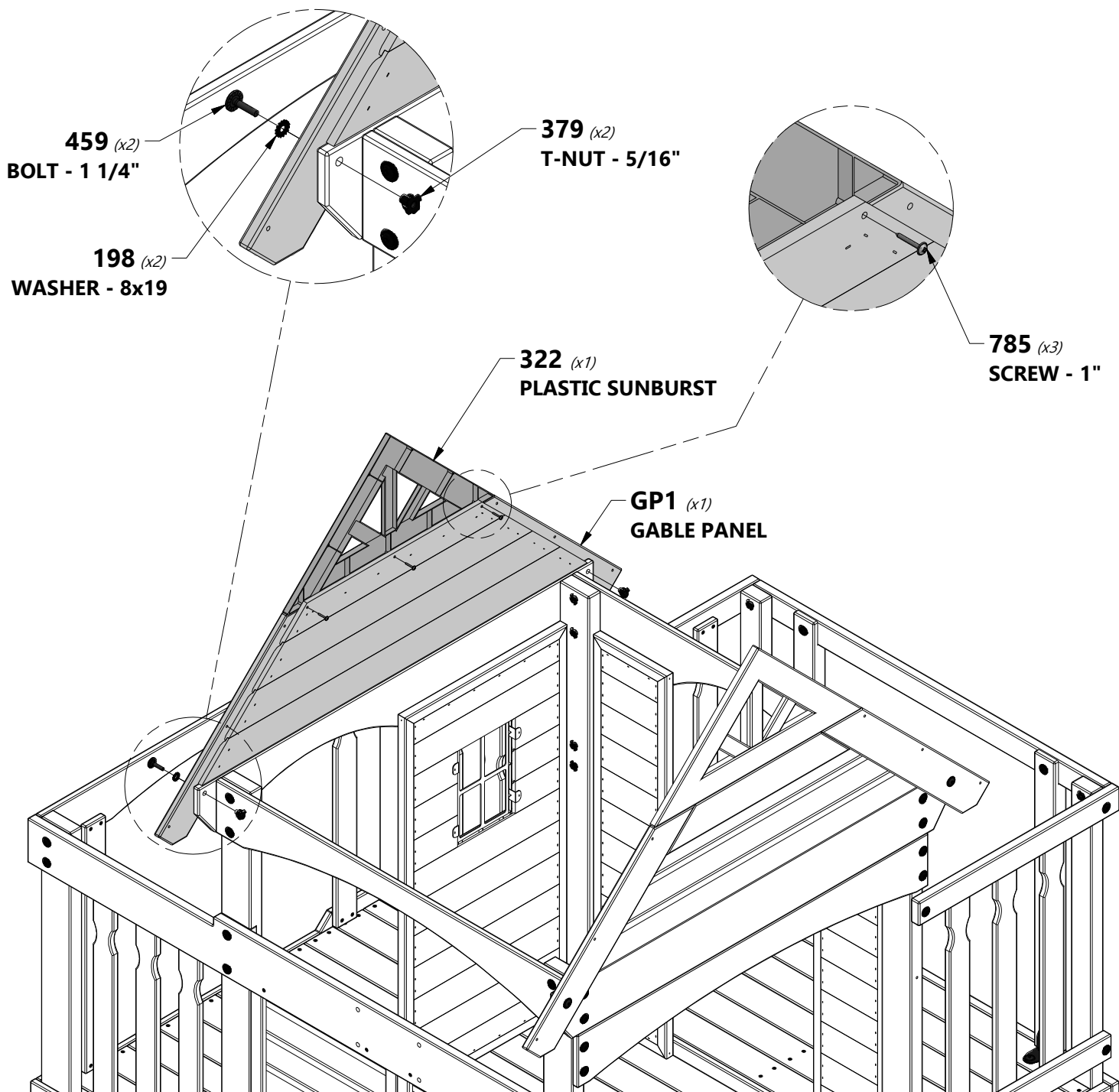

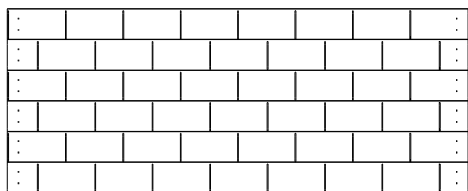

RP2 | ROOF PANEL - W2A02093
(x2) | 1 3/8"x48"x19 1/8" (35x1220x486)



H100089 | SCREW PFH
(x4) | 8x1 3/4



H100180 | SCREW PWH
(x8) | 8x1-1/4

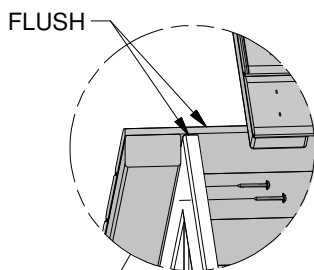

RP2 (x2)
ROOF PANEL

180 (x8)
SCREW - 1-1/4

089 (x4)
SCREW - 1 3/4"

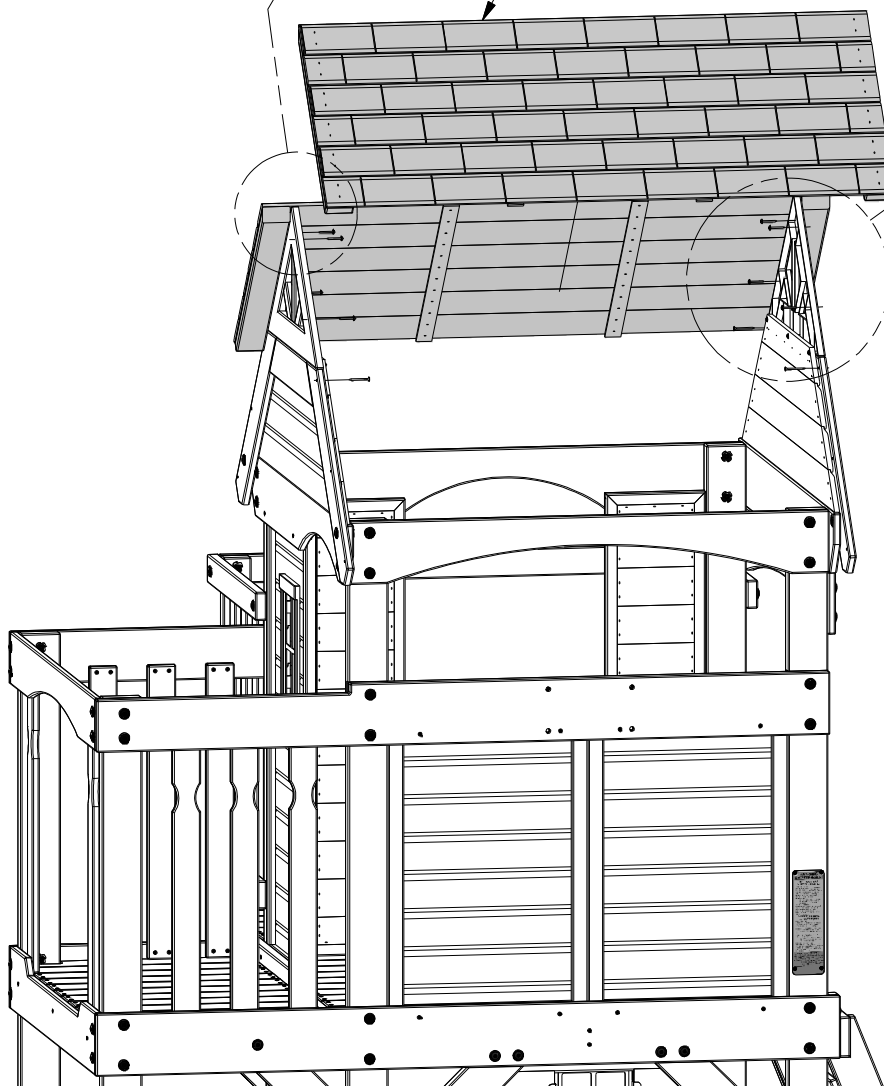
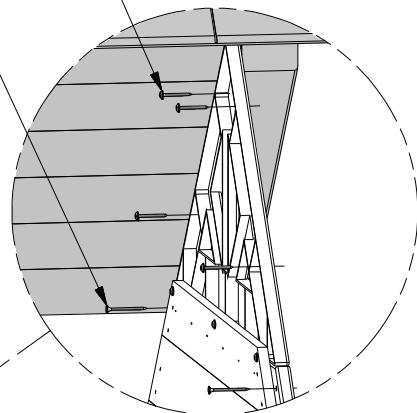

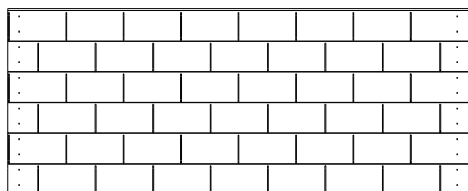

RP1 | ROOF PANEL - W2A02092
(x2) | 1 3/8"x48"x19 3/8" (35x1220x491)



H100089 | SCREW PFH
(x8) | 8x1 3/4

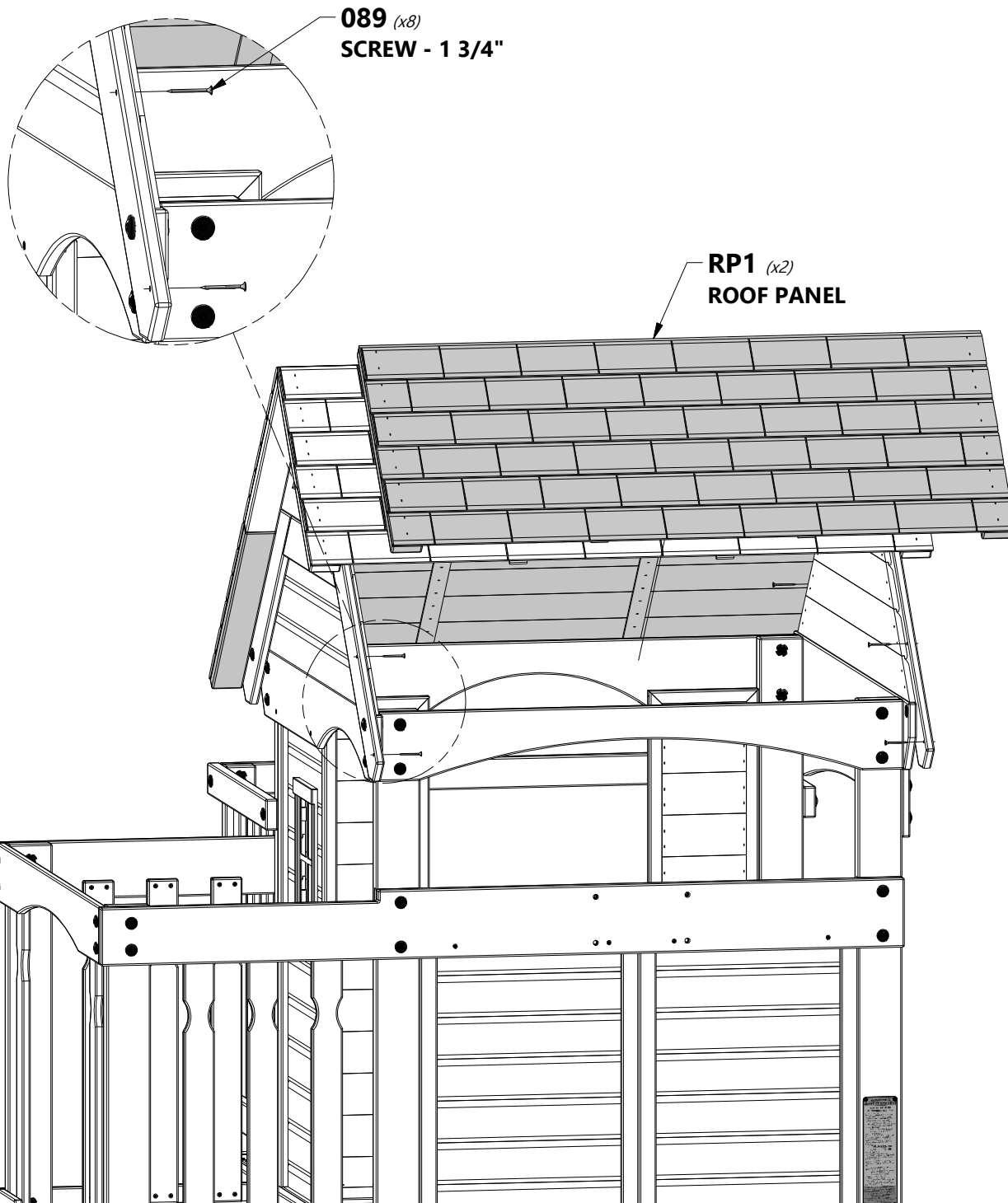

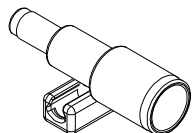

A6P00096 | TELESCOPE
(x1)



H100088 | SCREW PFH
(x2) | 8x1 1/8"

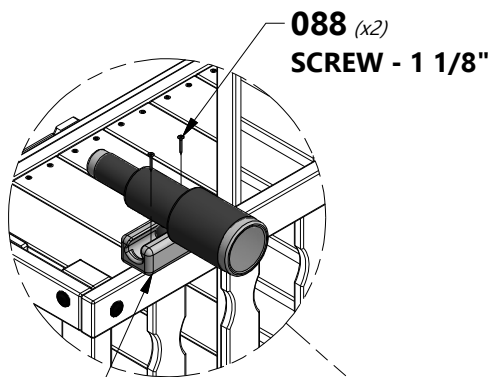

096 (x1)
Telescope

088 (x2)
SCREW - 1 1/8"



TIP:
APPROXIMATE LOCATION
FOR TELESCOPE

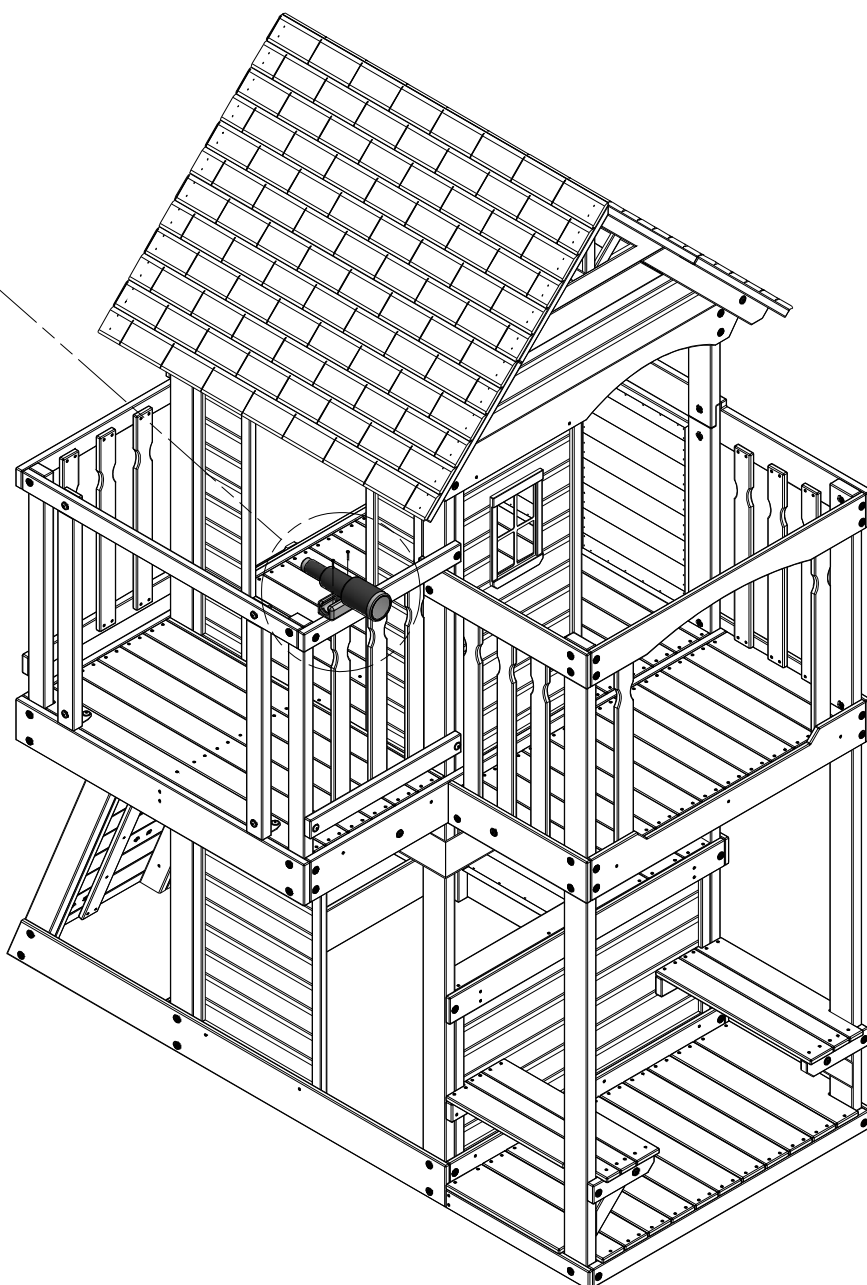

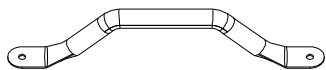

A100118 | **HAND GRIP**
(x2) | **METAL GREEN**
381 c/c



H100458 | **LAG SCREW WH BLK**
(x4) | **5/16x2**

458 *(x4)*
LAG SCREW - 2"

118 *(x2)*
HAND GRIP METAL GREEN 381 c/c

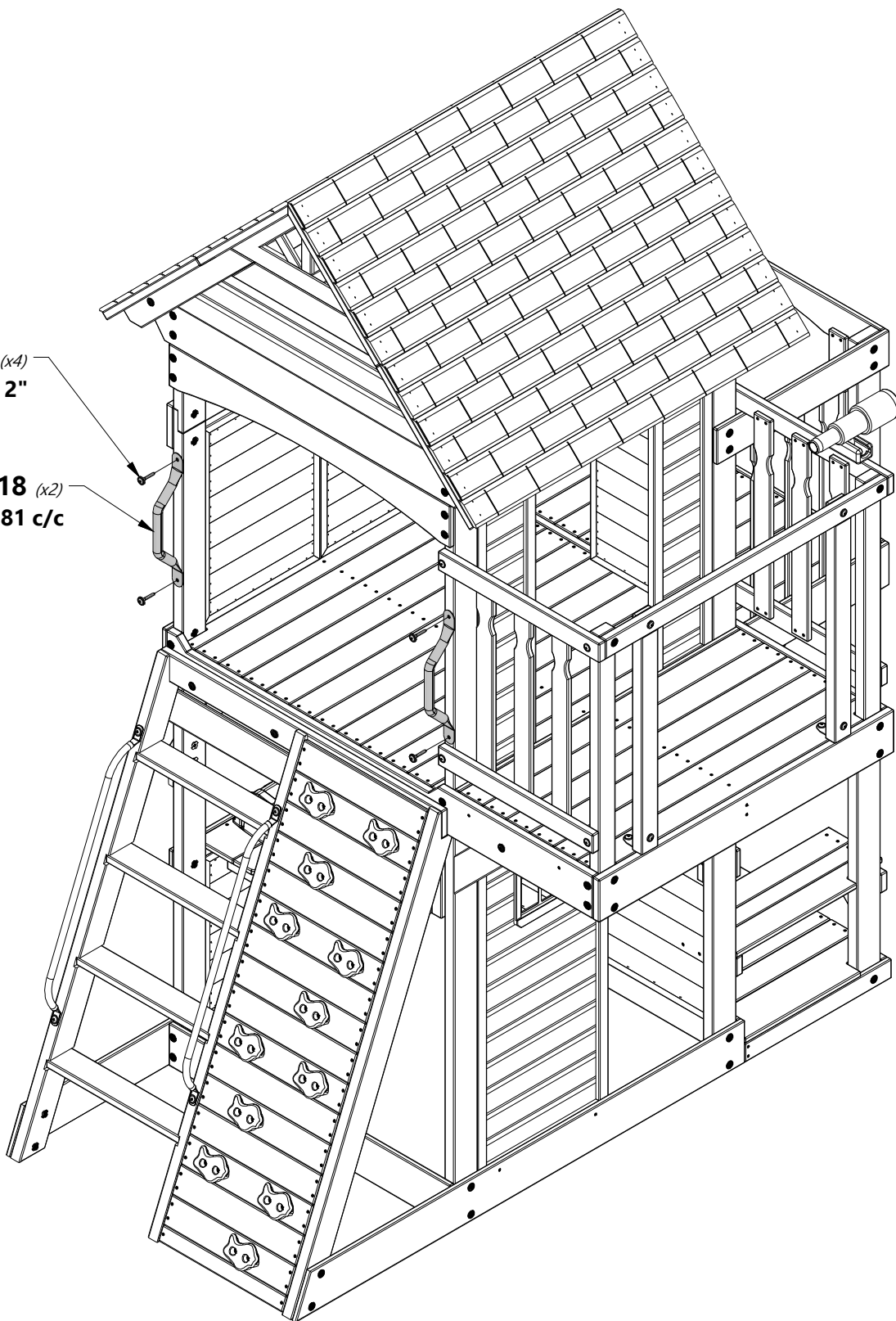

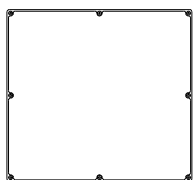

**A6P00324 | CHALK BOARD
(x1) | LARGE**



**H100392 | SCREW PWH BLK
(x2) | 8x3/4**



**H100408 | SCREW PWH BLK
(x6) | 8x1/2**

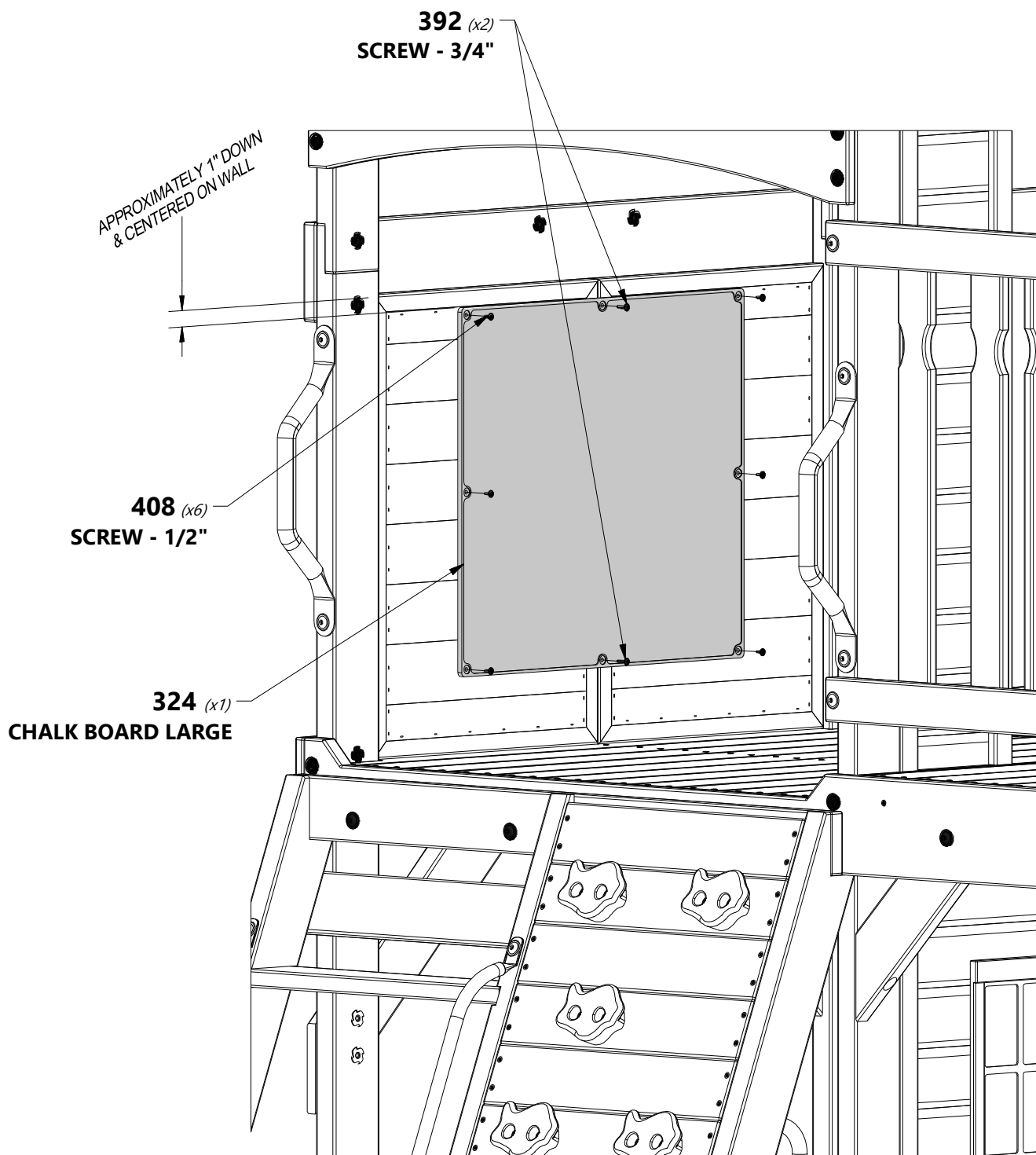



SETUP

WEB SWING

WEB SWING SETUP INSTRUCTIONS:

FOLLOW INSTRUCTIONS BELOW BEFORE USING THE WEB SWING.



H100832 | BOLT PTH
(4) | 1/4x3/4



H100831 | NUT BARREL PTH BLK
(4) | 1/4x3/4

IMPORTANT:
SLIDE ROPE LOOPS OVER TUBE ENDS FIRST!

SLIDE NARROW END OF TUBES INTO LARGER OPENING AFTER SLIDING ROPE LOOPS ONTO TUBES.

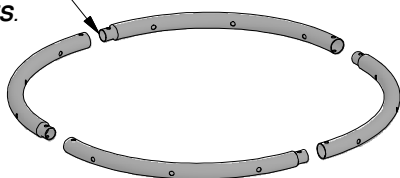

NOTE: ROPE WEBBING NOT SHOWN IN ILLUSTRATION FOR CLARITY.

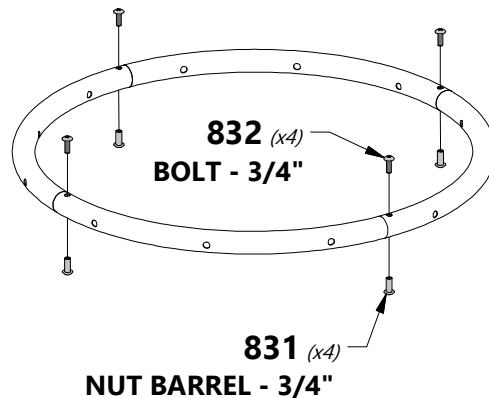

Note: It is important that the web swing hang level.

IMPORTANT
TO ENSURE STRAIGHT SWINGING MOTION, ADJUST BOTH "S" BRACKETS UNTIL WEB SEAT IS LEVEL.

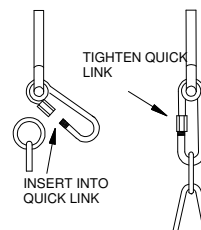
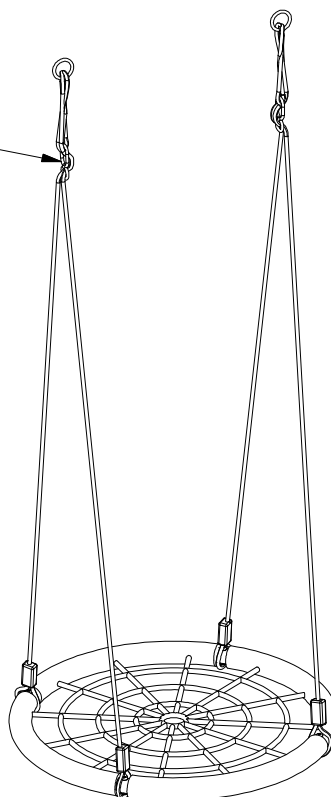



FORT ASSEMBLY

STEP 47

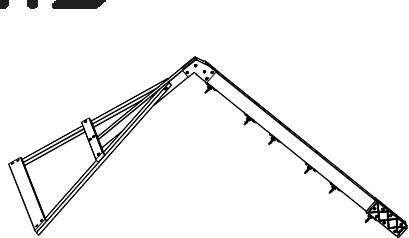

ASSEMBLY (x1) | SWINGBEAM



A4M01415 (x1) | 26" WEB SWING (EU)



A6P00397 (x2) | SWING



H100481 (x4) | BOLT HEX BLK 5/16x1 1/4



H100478 (x4) | WASHER FLAT BLK 8x27



H100477 (x4) | WASHER SPLIT BLK 5/16



NOTE:

WHEN HANGING YOUR SWINGS, IT IS REQUIRED TO ONLY TRIM AROUND THE SPECIFIC CHAIN LOOP THAT ALLOWS THE BOTTOM OF THE SWING SEAT, (WHEN SITTING ON IT) TO BE NO LOWER THAN (35CM) 13 7/8 INCHES FROM THE GROUND.

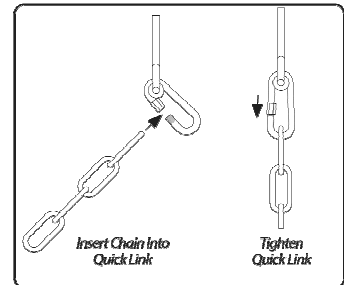
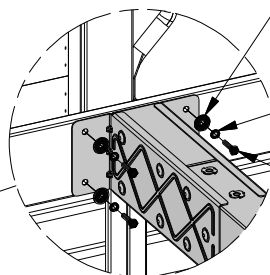
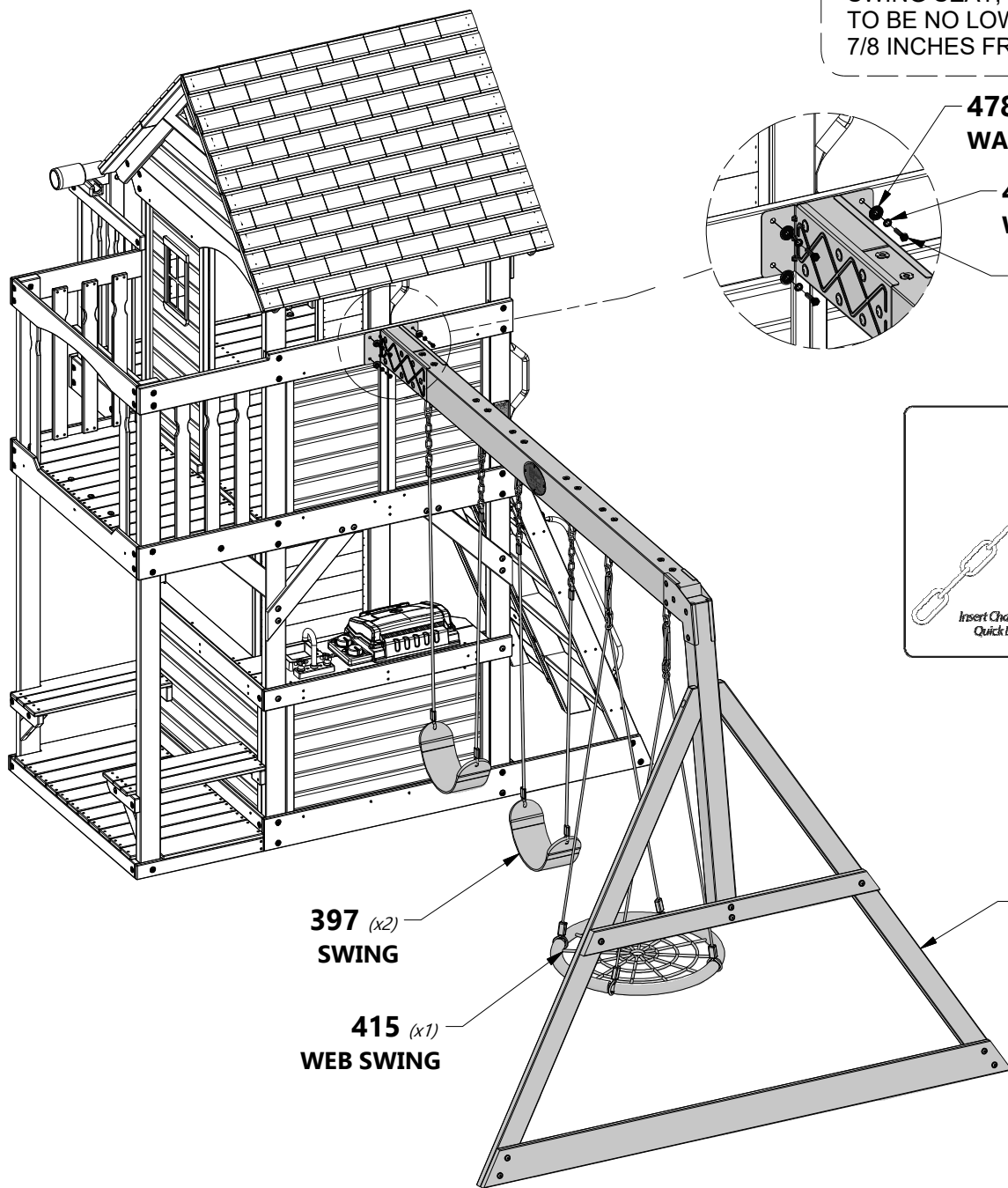

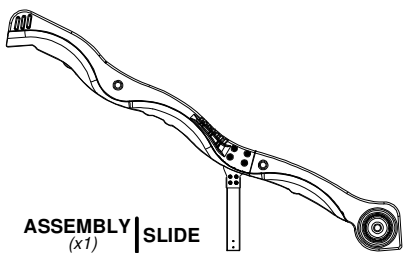



H100115 | BOLT WH
(x3) | 5/16x1/2

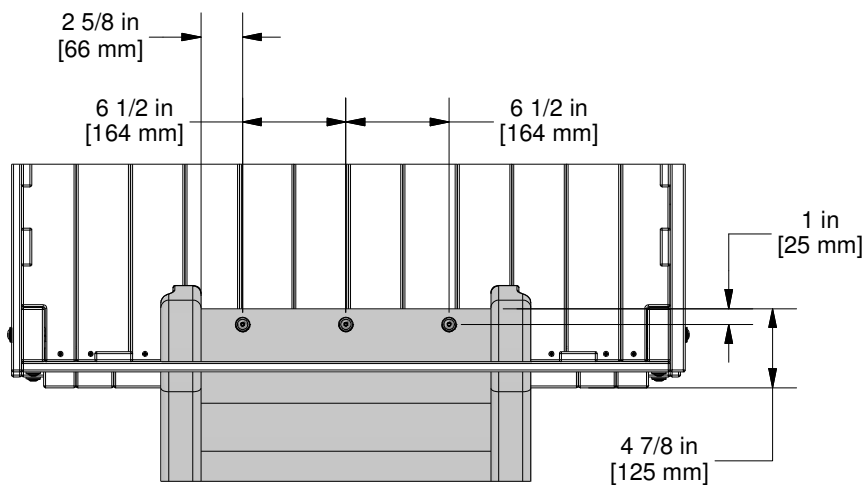

H100074 | T-NUT
(x3) | 5/16



TOP VIEW

NOTE:
 USING DIMENSIONS SHOWN DRILL (3) 3/8" (10mm) HOLES THROUGH SLIDE & FLOOR. ATTACHED SLIDE USING SUPPLIED HARDWARE.

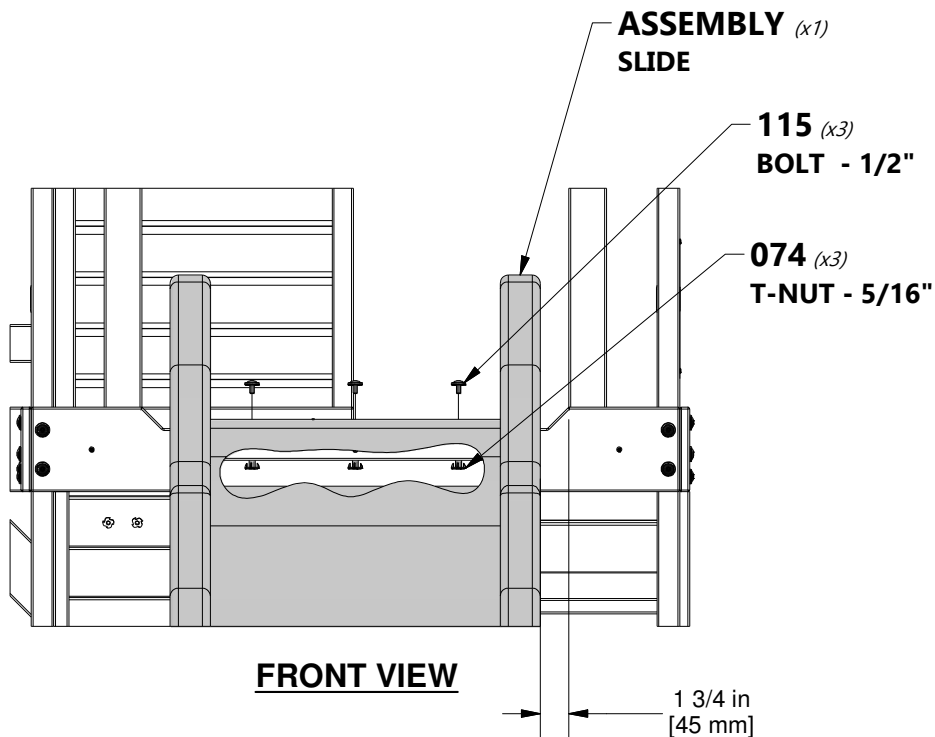

FRONT VIEW

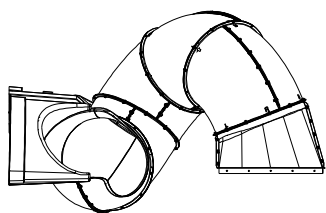

9198036 | TUBE SLIDE
(x1)



H100797 | SCREW PWH BLK
(x18) | 8x1



NOTE:

FOR ASSEMBLY OF THE TUBE SLIDE, PLEASE REFER TO THE TUBE SLIDE ASSEMBLY MANUAL FOUND IN THE TUBE SLIDE BOX.

036 (x1)
TUBE SLIDE

797 (x18)
SCREW - 1"

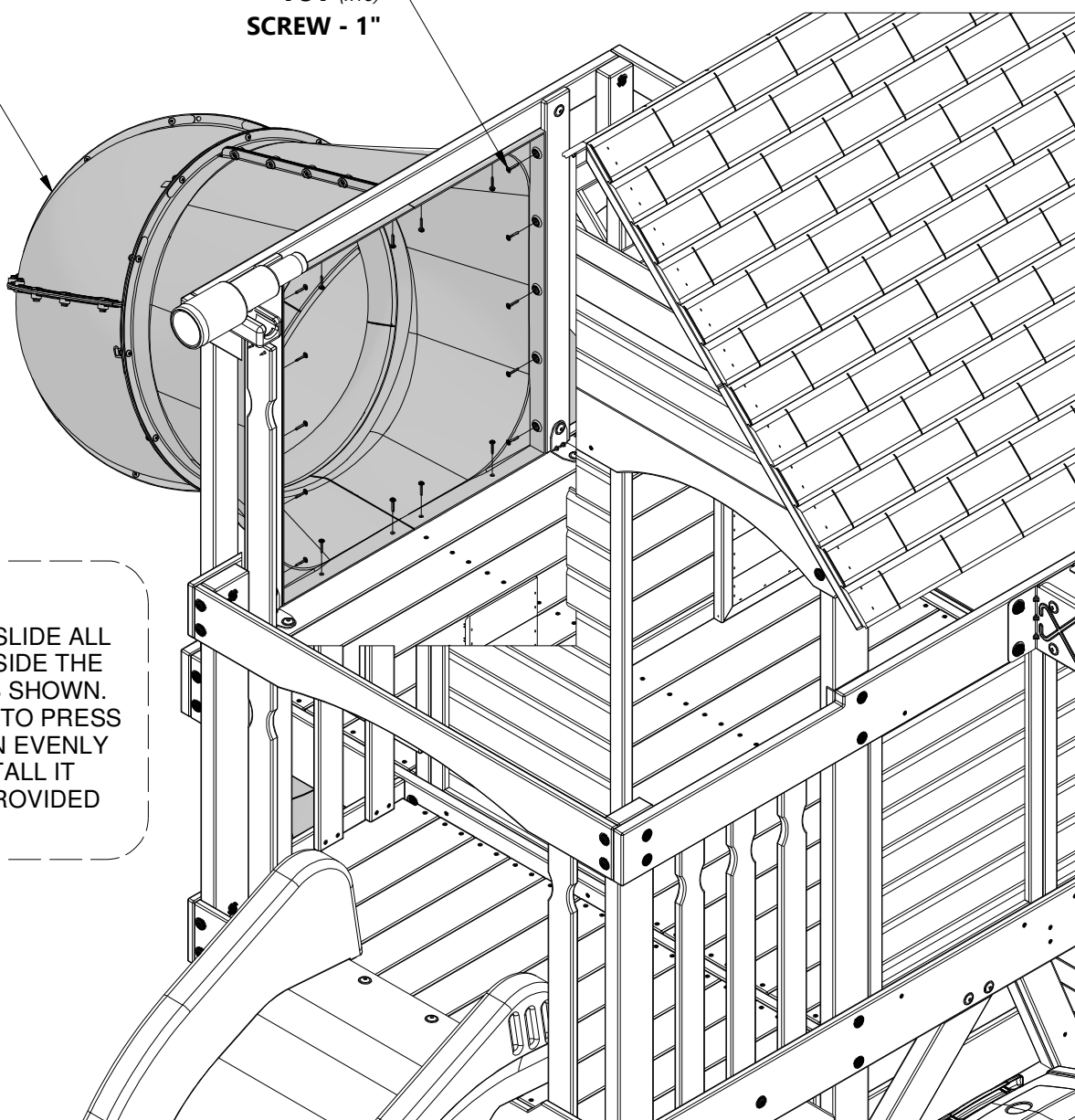

TIP:

PLACE THE SLIDE ALL THE WAY INSIDE THE OPENING AS SHOWN. MAKE SURE TO PRESS THE SLIDE IN EVENLY AS YOU INSTALL IT WITH THE PROVIDED HARDWARE.



A100178 | AUGER GROUND STAKE
(x6)



H100468 | BOLT WH BLK
(x2) | 5/16x1



H100663 | BOLT WH BLK
(x4) | 5/16x3/4



H100469 | NUT BARREL WH BLK
(x6) | 5/16x5/8



H100199 | WASHER LOCK EXT BLK
(x6) | 12x19



NOTE:

TWIST GROUND STAKE INTO THE GROUND WHERE SHOWN. THEN USING GROUND STAKE AS A GUIDE, DRILL A 7/16" (10mm) HOLE FOR HARDWARE.

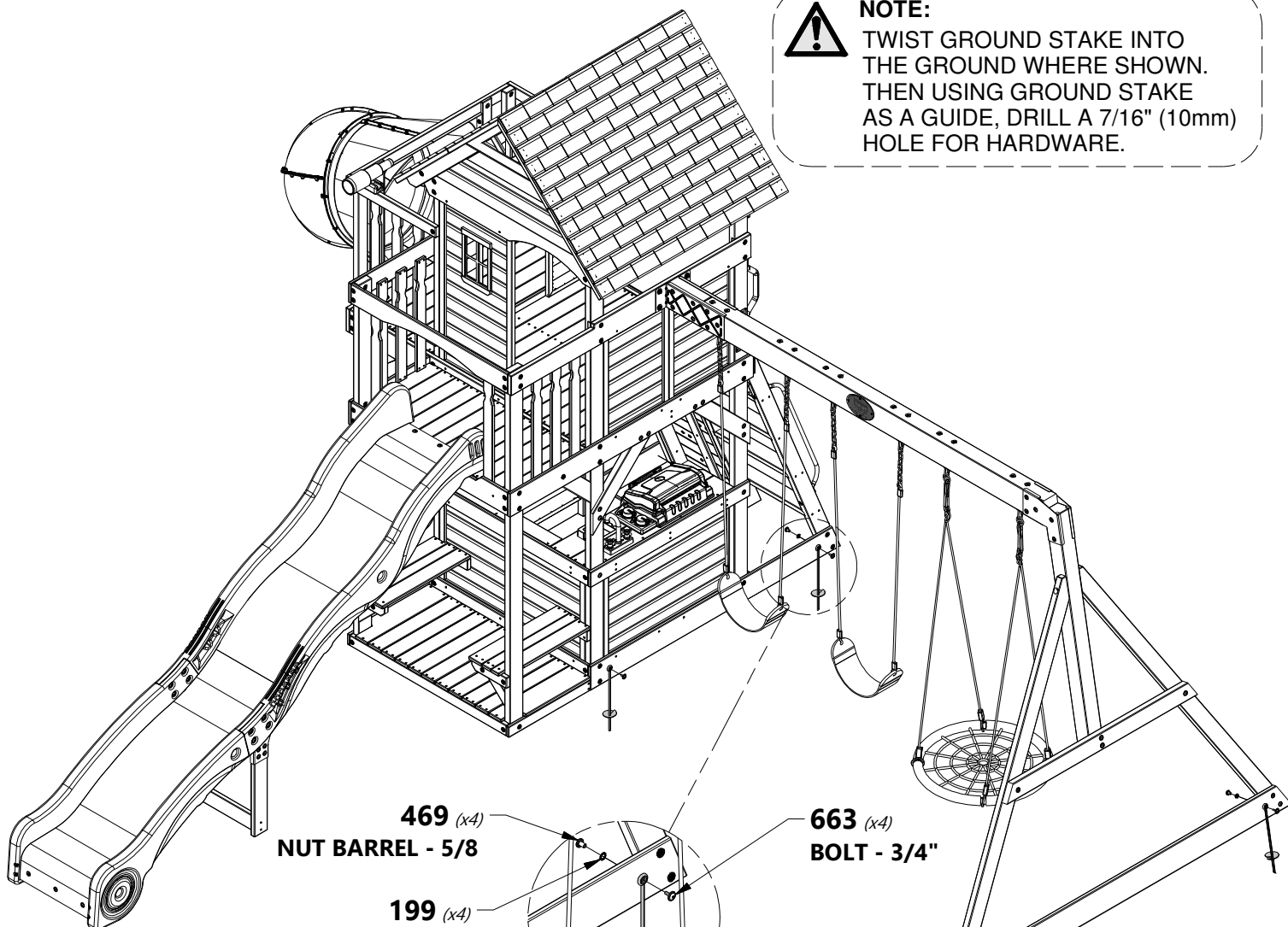

NOTE:

GROUND STAKE LOCATIONS REPEAT ON OPPOSITE SIDE.

469 (x2) NUT BARREL - 5/8

199 (x2) WASHER - 12x19

178 (x2) AUGER GROUND STAKE

468 (x2) BOLT WH - 1"