

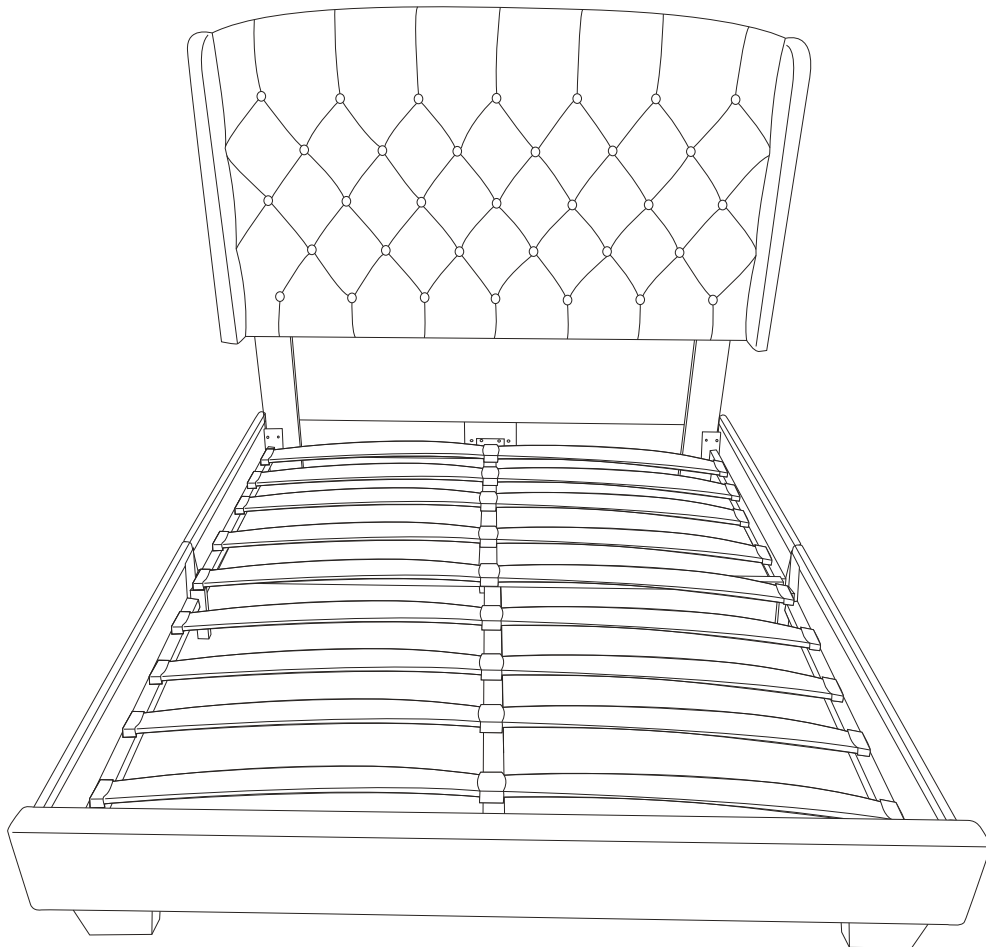

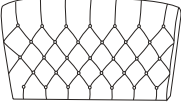

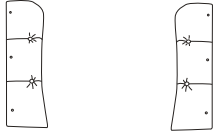

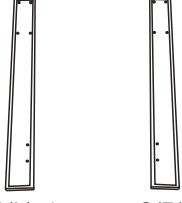



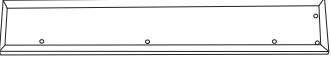
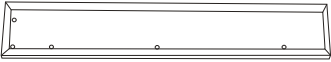
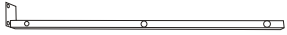

# stylor bed

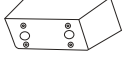



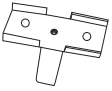

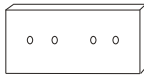
# ASSEMBLY INSTRUCTION

## PartsList

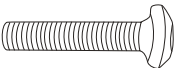
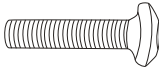
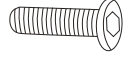
<p><b>A</b></p>  <p>x1</p>	<p><b>B</b></p>  <p>B(L)x1    B(R)x1    x1</p>	<p><b>C</b></p>  <p>C(L)x1    C(R)x1    x2</p>	<p><b>D</b></p>  <p>x1</p>
<p><b>E</b></p>  <p>x2</p>	<p><b>F</b></p>  <p>x2</p>	<p><b>G</b></p>  <p>x2</p>	<p><b>H</b></p>  <p>x2</p>
<p><b>I</b></p>  <p>x1</p>	<p><b>J</b></p>  <p>x2</p>	<p><b>K</b></p>  <p>x20</p>	<p><b>L</b></p>  <p>Legs    x2</p>
<p><b>M</b></p>  <p>Single holes    x20</p>	<p><b>N</b></p>  <p>Both holes    x10</p>	<p><b>O</b></p>  <p>x1</p>	<p><b>P</b></p>  <p>x1</p>
<p><b>Q</b></p>  <p>x2</p>	<p><b>R</b></p>  <p>x1</p>		

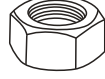
## HardwareList

<p>① M4x55</p>  <p>4pcs</p>	<p>② M6x50</p>  <p>6pcs</p>	<p>③ M6x45</p>  <p>12pcs</p>	<p>④ M6x40</p>  <p>21pcs</p>	<p>⑤ M6x30</p>  <p>10pcs</p>
<p>⑥ M6x16</p>  <p>8pcs</p>	<p>⑦</p>  <p>2pcs</p>	<p>⑧</p>  <p>22pcs</p>	<p>⑨</p>  <p>1pc</p>	

# ASSEMBLY INSTRUCTION

1

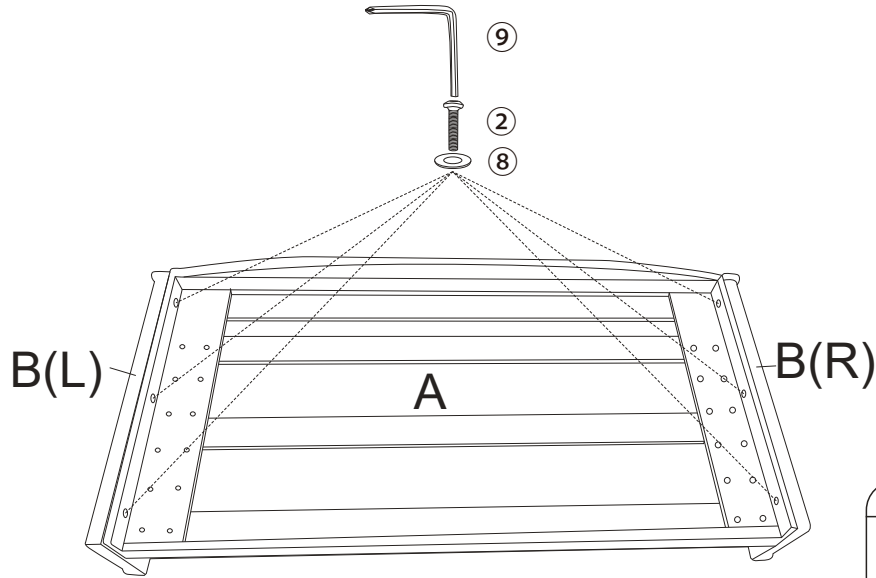

2

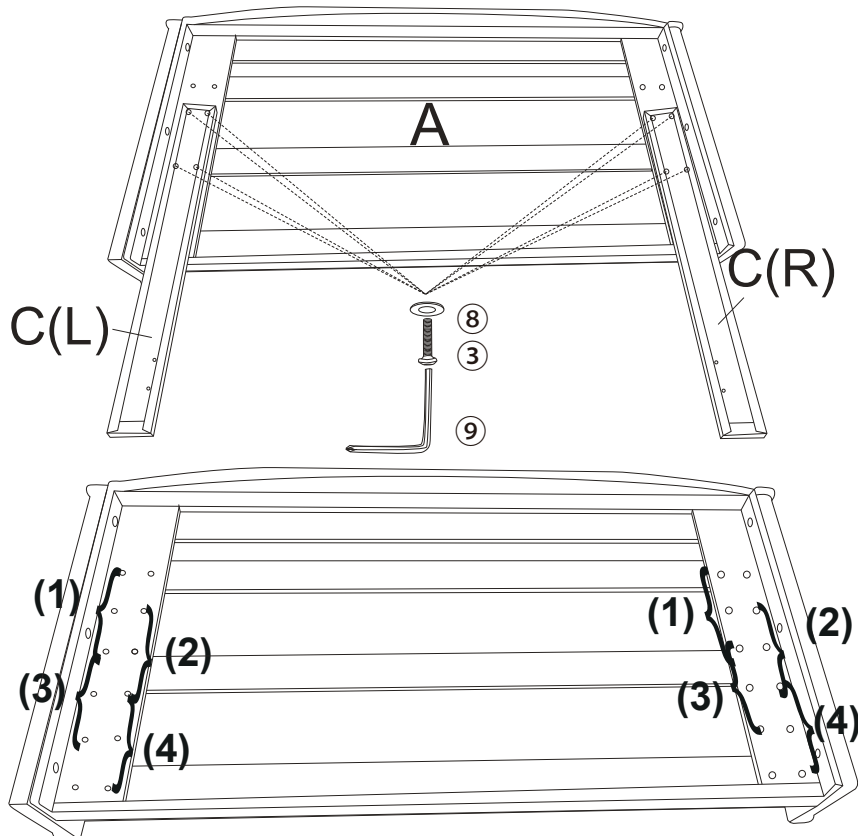

For the convenience of installation, please lock 50% of all screws in this step, and then lock 100% after step 3 is completed  
 Part C(L) and Part C(R) is installed onto Part A as shown in the figure.  
 And there are four installation methods to adjust the height of the bed.  
 Adjustable bed height range: 1.2m-1.5m (manual measurement:  $\pm 2\text{cm}$ )

3

# ASSEMBLY INSTRUCTION

3

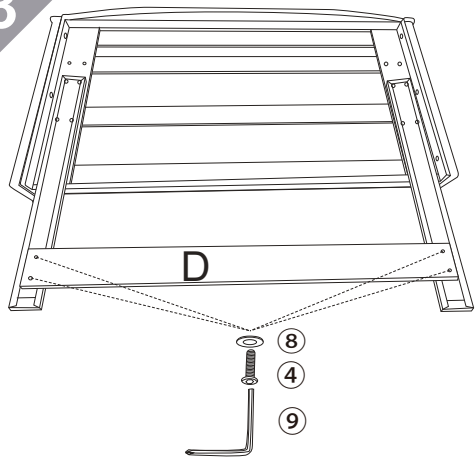

NO!

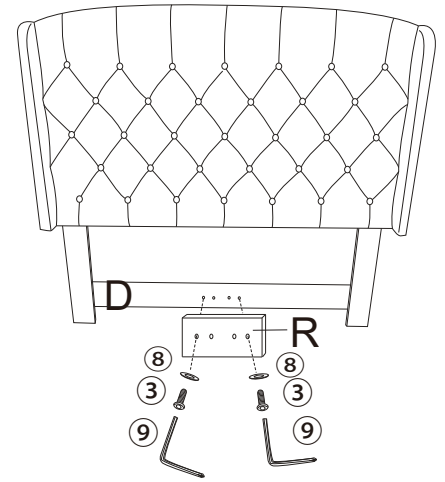
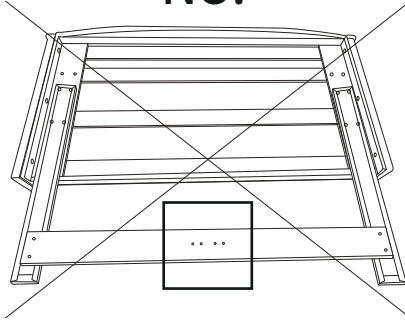

When installing the Part D, pay attention to distinguish between the front and the back.  
There are two holes in the middle of the front.

④	4	③	2	⑧	6
M6x40		M6x45			

4

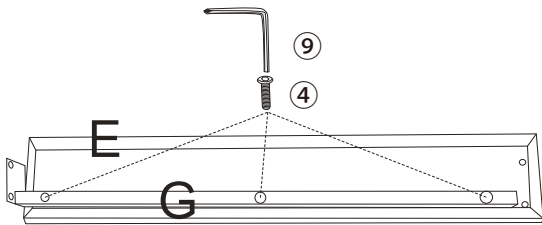

✓

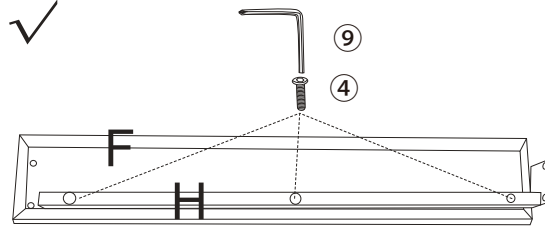

X2

④	12
M6x40	

NO! X

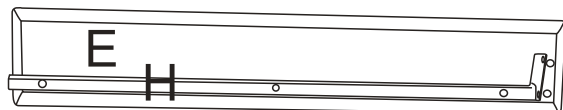
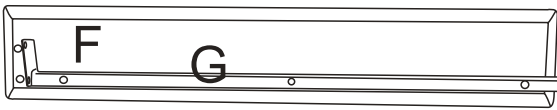
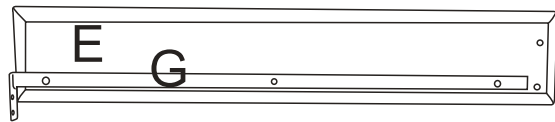
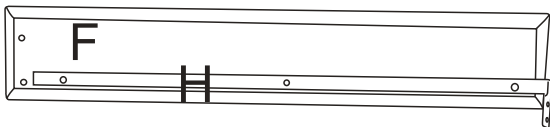

5

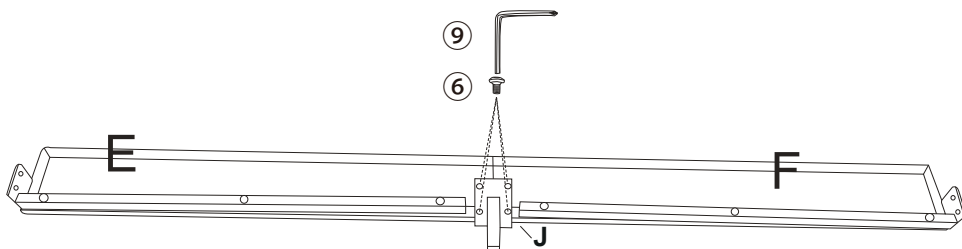
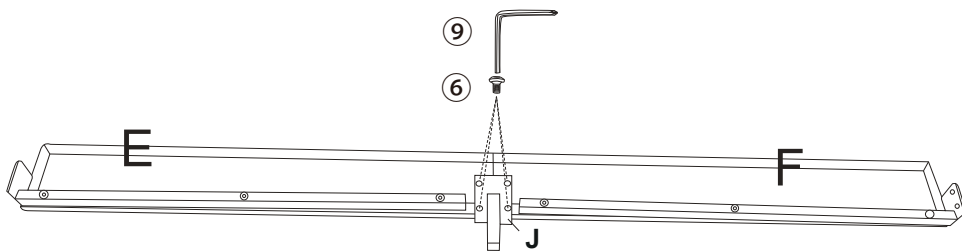

⑥	8
M6x16	

# ASSEMBLY INSTRUCTION

6

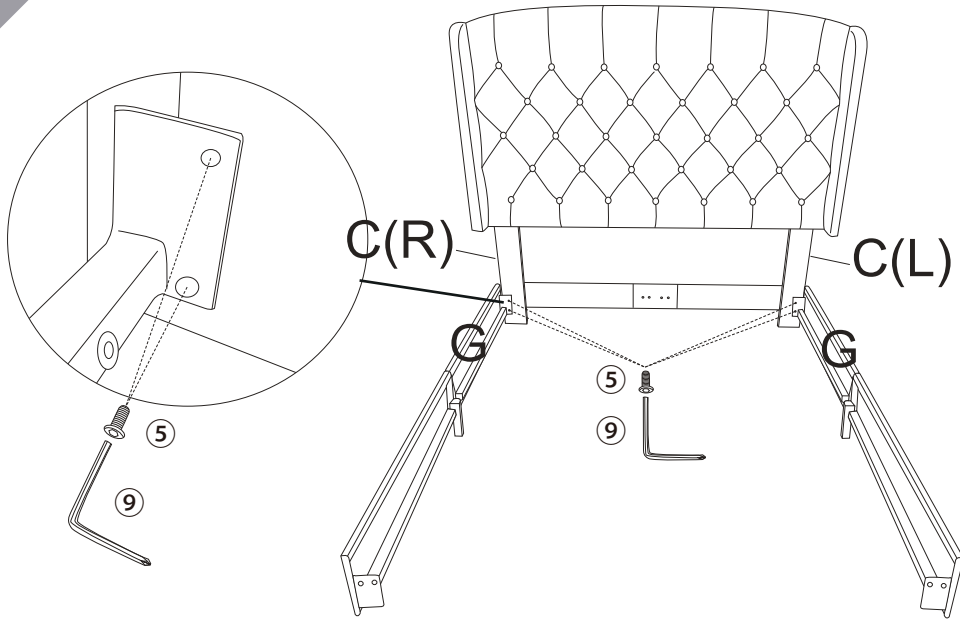

5	4
M6x30	

7

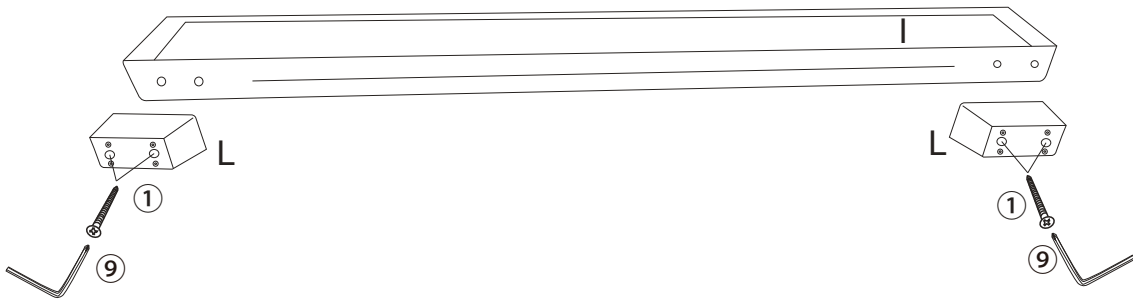

1	4
M4x55	

8

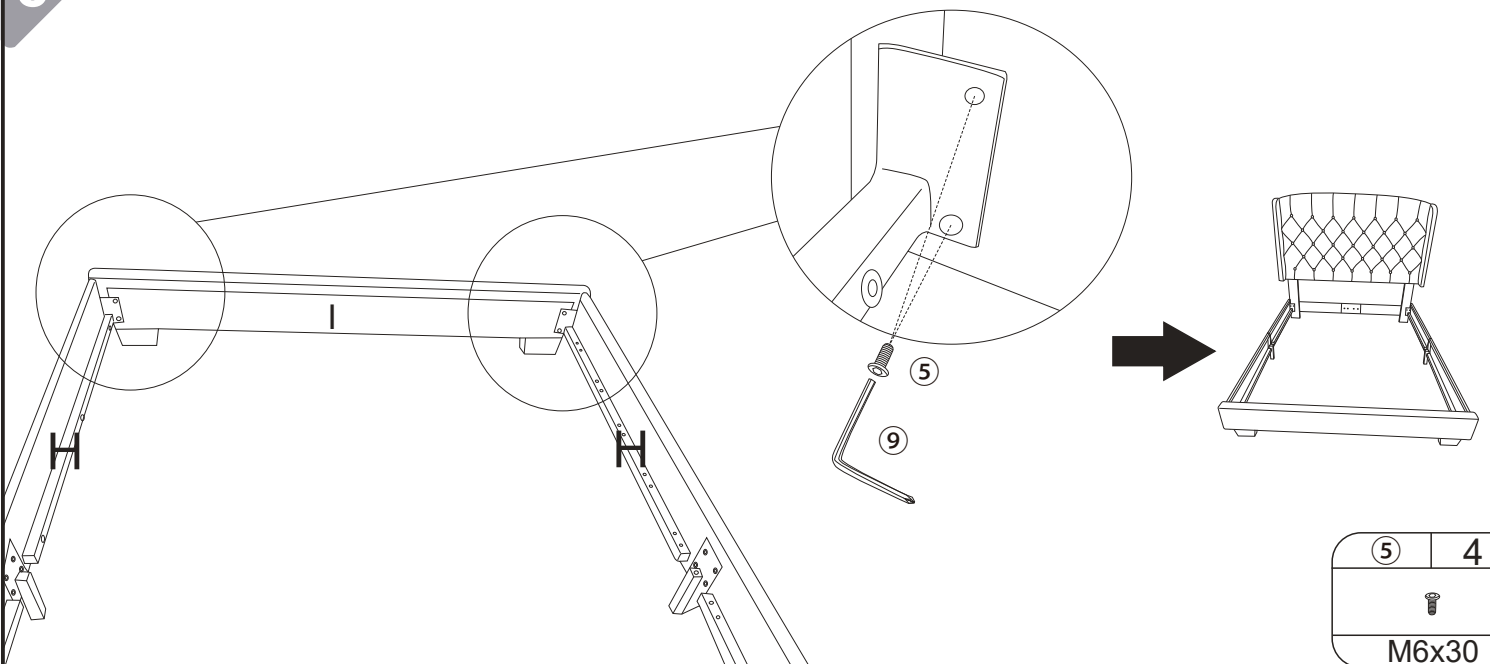



5	4
M6x30	

# ASSEMBLY INSTRUCTION

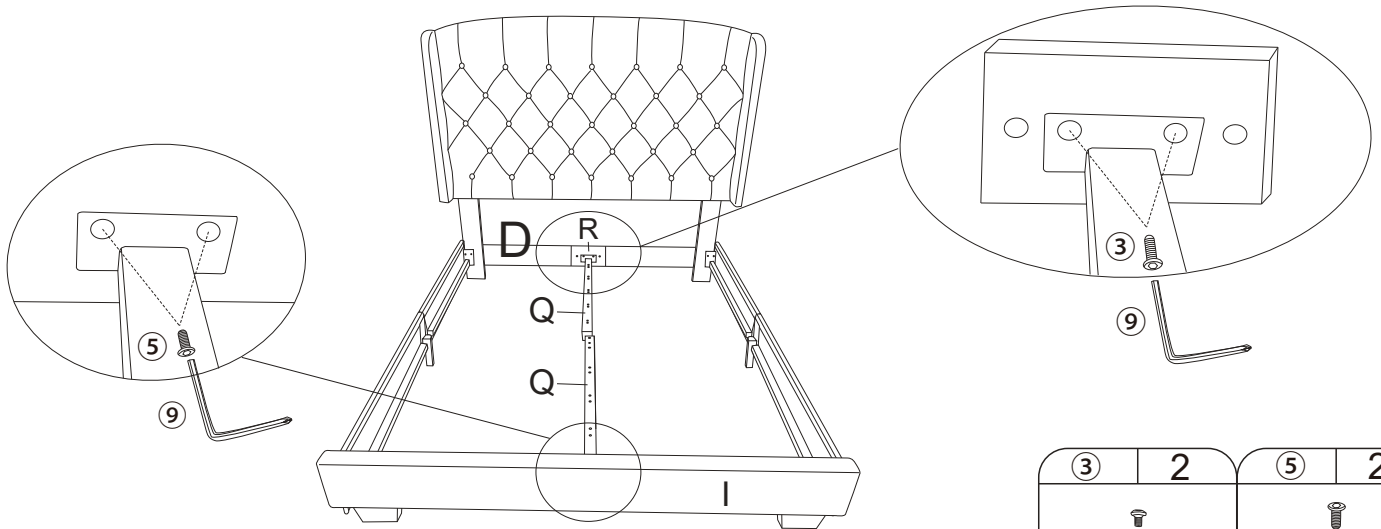

9

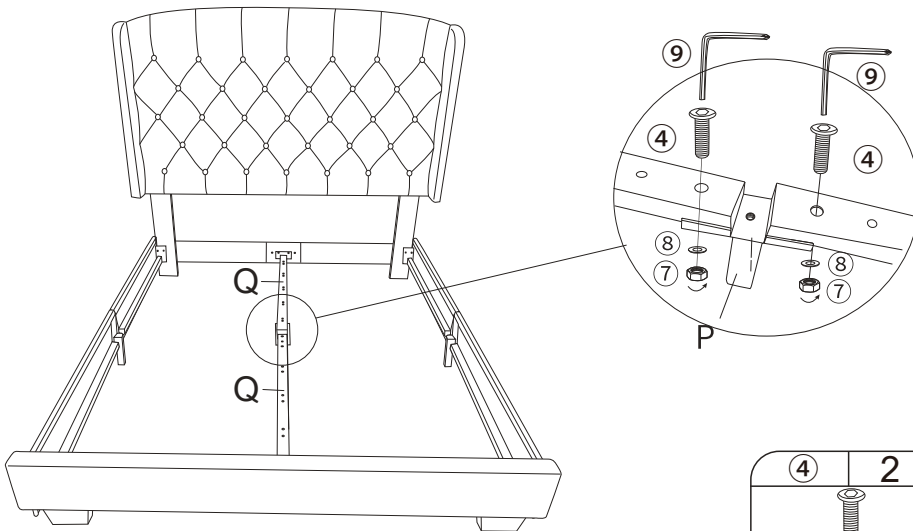

3	2	5	2
			
M6x45		M6x30	

10



4	2	8	2	7	2
					
M6x40					

11

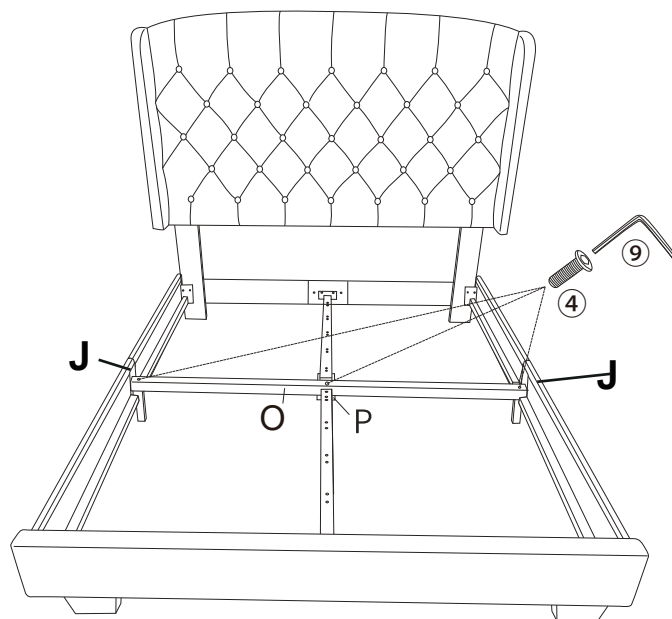

4	3
	
M6x40	

# ASSEMBLY INSTRUCTION

12

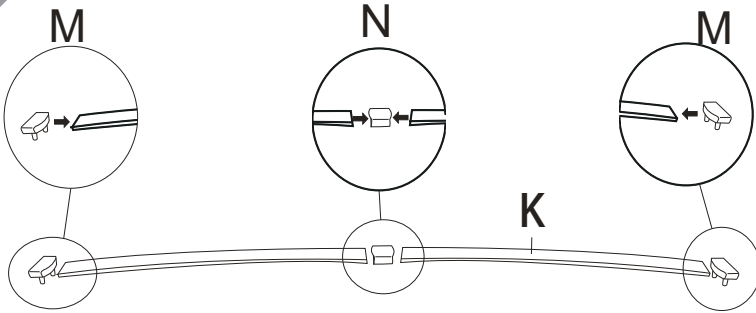

X10



NO!

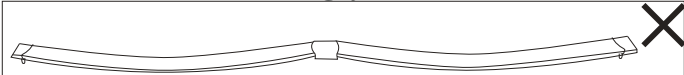

13

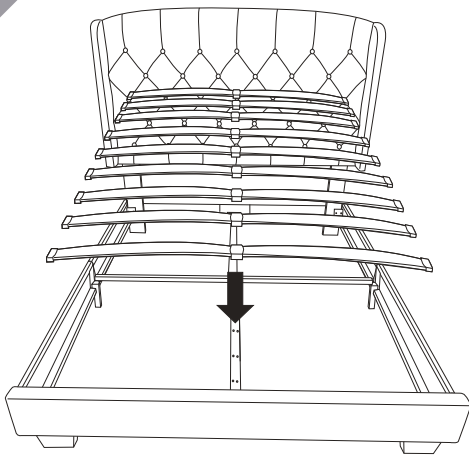

Attention:  
on the side

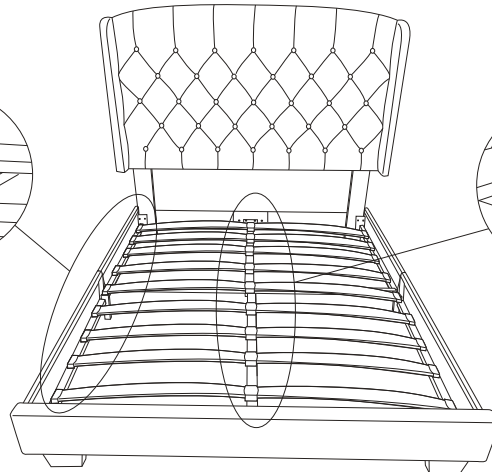
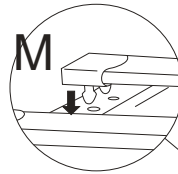

Attention:  
on the middle

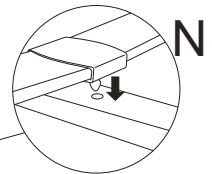

14

