

# SIDE TABLE

## ASSEMBLY INSTRUCTIONS

### PARTS AND FITTING PACKAGING DETAIL

#### BOX #1

A. TABLE TOP 1PC

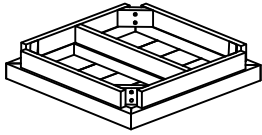

B. LEG 4PCS

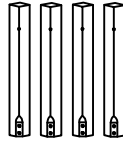



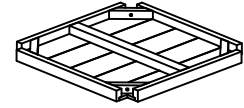

C. SHELF 1PC

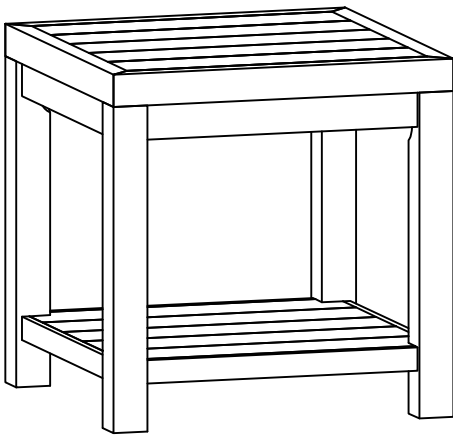

#### SIDE TABLE ASSEMBLED

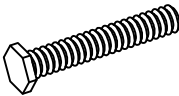

#### HARDWARE \* PACKED IN BOX #1

H1	BOLT 8 X60mm	12 PCS	H2	FLAT WASHER M8	12 PCS
					
H3	HEX WRENCH 13mm	1 PC	H4	SPRING WASHER M8	12 PCS
					

YOUR BOX MAY CONTAIN EXTRA HARDWARE

#### STEP 1

Attach Legs (B) to Table Top (A) using Bolts (H1), Flat Washers (H2), and Spring Washers (H4). Tighten with Hex Wrench (H3).

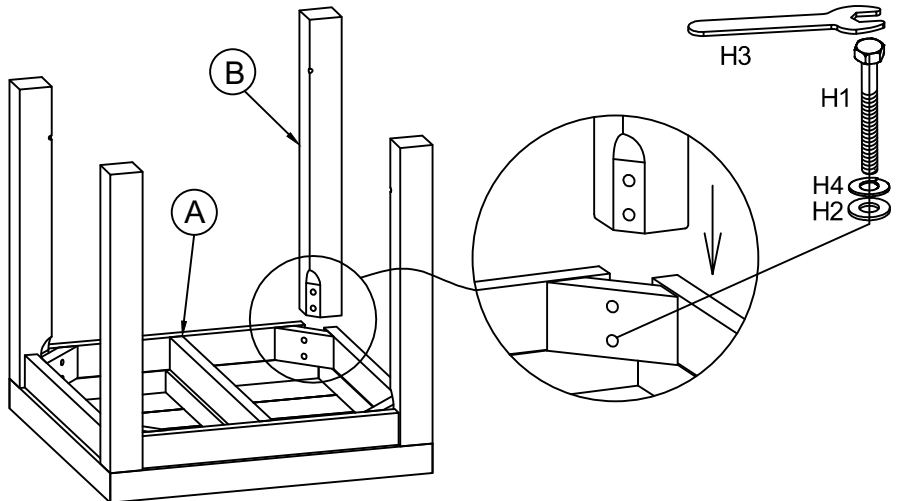

#### STEP 2

Attach Shelf (C) to the Legs using Bolts (H1), Flat Washers (H2), and Spring Washers (H4). Tighten with Hex Wrench (H3).

