



Outdoor
Living Today

ASSEMBLY MANUAL

12x8 Cabana

Bevel

Stock Code:

CB128-AK-CEDAR

CB128-AK-METAL

CB128-AK-PLY

Version #1.1

April 1, 2025



CONTACT

ADDRESS

9393 287th Street,
Maple Ridge, British Columbia,
Canada V2W 1L1

PHONE & FAX

Toll Free: 1-888-658-1658

Fax:

ONLINE

Email: olmsupport@outdoorlivingtoday.com

Web: www.outdoorlivingtoday.com

What You Need to Know

Thank you for purchasing a 12x8 Cabana.

Please take the time to identify all the parts prior to assembly.

IMPORTANT INFORMATION

It is the sole responsibility of the customer to check with your local municipal or county by-laws before ordering this product to confirm it complies with building codes in your area.

If the product is elevated, any structural and building code requirements are solely the customer's responsibility, and should be abided by.

Snow load ratings vary by geographical location. If heavy or wet snowfall occurs, it is advisable to sweep snow off roof frequently. In areas with high or gusty wind conditions, it is advisable to install the structure securely to the ground.

Have a regular maintenance plan to ensure screws, doors, windows and parts are tightly affixed.

All structures purchased from Outdoor Living Today are covered for a period of one year for defects in manufacturing and workmanship. Costs incurred for customer installations are not included.

Failure to use supplied parts included in this kit could result in poor product performance and may void your warranty. Please contact Outdoor Living Today's Customer Toll Free Line if you plan to deviate from our written instructions.

Warranty

In the event of a missing or broken piece, please contact Outdoor Living Today Customer Support at olmsupport@outdoorlivingtoday.com within 30 days of the delivery of your purchase. It is our commitment to you to courier replacement parts, free of charge, within 10 business days of this notification. Replacement parts will not be provided free of charge after the 30 day grace period.

Customer agrees to hold Outdoor Living Today and any Authorized Dealers free of any liability for improper installation, maintenance and repair.

What to do Before my Shed Arrives?



Become familiar with this assembly manual and determine if you can complete the project yourself or will require a professional contractor.



One helper is recommended to assist in constructing your shed. It generally takes two people two days to assemble a shed. If you're hiring a contractor, their rate should be in line with that duration of work.



Clear the construction area and ensure a clear pathway for delivery when the freight company arrives. Remove all debris: roots, grass, rocks, etc.



Excavate the site. Contact your local utilities company to ensure there are no gas or electric lines buried in the area before digging.



Decide on the type of foundation you will be using: Concrete slab, or 4-6 inches of crushed gravel with paver stones or 4x4 stringers.

You can find the footprint for your shed on Page 3 of your Assembly Manual.



If doing the assembly yourself, have all the necessary tools ready to go and in working condition. A list of required tools can be found after the parts list.

Foundation Types for 8x12 Garden Shed

1.

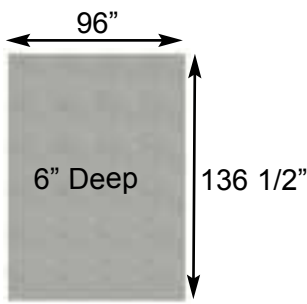

Concrete Foundation

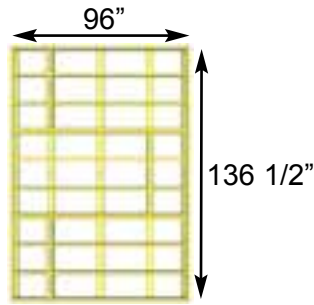

Floor Frame



Completed Foundation

Concrete Slab Foundation:

- Slab must be at least the same size as assembled floor frame (136 1/2" x 96") or larger.
- 6" Deep foundation.
- 1.7 Cubic Yards of concrete required.
- A concrete slab will have the longest durability out of your foundation options.

Once level, a concrete slab is the easiest surface to build on.

2.

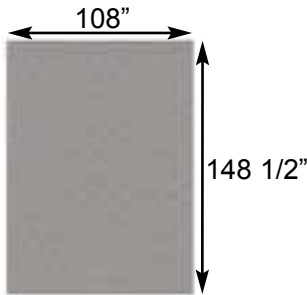

Gravel Foundation

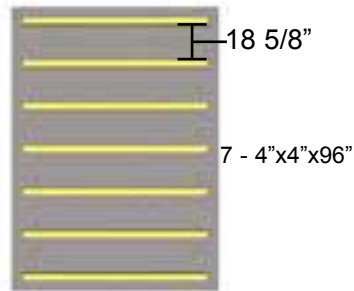

Gravel Foundation with treated stringers

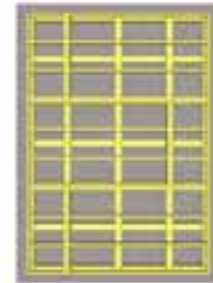

Completed Foundation

Gravel with 4x4 Pressure Treated Stringers:

- Excavate at least 6" deep, and 6" wider than floor frame on each side.
- 2.1 Cubic Yards of gravel required, approximately 19 wheelbarrows.
- 7 - 4x4 Pressure Treated Stringers 8' long required.
- Evenly spaced, with one at each end of floor frame.

Saves money on materials, easy to level and work with.

3.

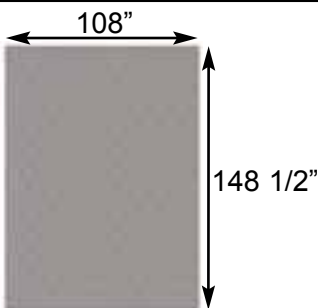

Gravel Foundation

25 Patio Stones



Gravel Foundation with Patio Pavers



Completed Foundation

Gravel with Patio Paver Stones:

- Excavate at least 6" deep, and 6" wider than floor frame on each side.
- 2.1 Cubic Yards of gravel required, approximately 19 wheelbarrows.
- 25 patio pavers (8" x 8" or larger).
- Center patio paver stones underneath floor runners and underneath seams in floor joists.

Patio paver stones are widely available from most landscape stores.

Thank you for purchasing our 12x8 Cabana.
Please take the time to identify all the parts prior to assembly.

Parts List	Steps	D. Roof Section - METAL	Steps
A. Floor Section Floors 3 - 45 1/2" x 75" - Floor Joist Frames - Large 3 - 45 1/2" x 21" - Floor Joist Frames - Small 6 - 1 1/2" x 3 1/2" x 71 7/8" - Center Floor Joists - Unattached 10 - 1 1/2" x 3 1/2" x 68 3/16" - Floor Runners 3 - 45 3/8" x 74 7/8" - Plywood Floor - Large 3 - 45 3/8" x 20 7/8" - Plywood Floor - Small	A1 - A12	16 - 3/4" x 3 1/2" x 49 1/4" Roof Batten (outside) 8 - 3/4" x 3 1/2" x 45 1/2" Roof Batten (middle) 12 - 3/4" x 1 1/2" x 14 1/8" - Batten Spacers 8 - 61" long x 39" wide Metal Roof Panels 3 - 13"w x 60" Metal Ridge Cap Several Strips of Foam Enclosures for Metal Roof Ends	D1 - D16
B. Wall Section Main Wall Panels 7 - 45 1/2" x 75" - Solid Wall Panels 7 - 1 1/2" x 2 1/2" x 45 1/2" - Bottom Wall Plates 2 - 45 1/2" x 75" - Window Wall Panels 1 - 12" x 73" - Narrow Wall Panel Door Jambs & Header 1 - 1 1/2" x 3 1/2" x 73" - Vertical Door Jamb 1 - 2" x 3 1/2" x 45 1/2" - Door Header (Dado cut on edge) Top Wall Plates 6 - 3/4" x 2 1/2" x 32" - Side Top Plates (4 pieces angle cut on end, 2 piece straight cut both ends) 4 - 3/4" x 2 1/2" x 65 3/4" - Front & Rear Top Plates (angle cut edge) Gable Walls 4 - Gable Half Walls - Triangular Shaped Misc. Wall 1 pc - Spare Wall Siding	B1 - B8	D. Roof Section - PLYWOOD 2 - 5/8" x 78" x 45 1/4" - Plywood Roof	D1 - D6
C. Rafters 2 - 3/4" x 4 1/2" x 84" - Roof Ridge Boards 2 - 3/4" x 4 1/2" x 52 1/2" - Roof Ridge Boards 18 - 1 1/2" x 3 1/2" x 56 1/2" - Roof Rafters 4 - 1/2" x 4 1/2" x 68 1/4" - Soffits 3 - 3/4" x 3 1/2" x 72" - Roof Gussets (angle cut on ends)	C1 - C13	E. Misc. Section 10 - 3/4" x 4 1/2" x 45 1/4" - Bottom Skirting (Bevel) 4 - 7/8" x 2 1/2" x 75" - Filler Trim 5 - 3/4" x 1 1/2" x 45 1/4" - Top Wall Trim (Bevel) 4 - 3/4" x 4 1/2" x 45 1/4" - Horizontal Gable Trim (Bevel) 4 - 1/2" x 3 1/2" x 79" - Corner Trim 4 - 1/2" x 5 1/2" x 82" - Wide Corner Trim 2 - 1/2" x 2 1/2" x 79" - Rear Wall Narrow Trim 2 - 1/2" x 2 1/2" x 77 1/2" - Side Wall Narrow Trim 4 - 3/4" x 2 1/2" x 51" - Facia Nailing Strips 4 - 3/4" x 3 1/2" x 58" - Side Facia (Angle cut on ends - 2 right / 2 left) 4 - 3/4" x 3 1/2" x 71 3/4" - Front and Rear Facia 2 - Pentagon Facia Plate - For Side Facia Peaks 2 - Horizontal Gable Trim Detail Plates - 4 1/2" high 2 - Facia Detail Plates - 3 1/2" high 2 - 1/2" x 3 1/2" x 79" - Vertical Door Trim 1 - 1/2" x 2 1/2" x 79" - Front Wall Narrow Trim 1 - 1/2" x 1 1/4" x 32" - Horizontal Door Trim 1 - 1/2" x 1 1/4" x 7" - Horizontal Narrow Wall Trim 1 - 31 1/2" x 30" - Top Dutch Door Section 1 - 31 1/2" x 42" - Bottom Dutch Door Section 2 - 1/2" x 2 1/2" x 72" - Interior Vertical Door Stops 1 - 1/2" x 2 1/2" x 36" - Interior Top Horizontal Door Stop 2 - Metal Window Inserts 2 - Window Trim Pkgs - (1 - 24 1/16" angle cut / 3 - 23" square cut) 2 - Flower Box Kits 1 - Spare Wall Siding 2 - Spare Shingles - use to shim door, etc	E1 - E25
D. Roof Section - CEDAR 4 - Outer Roof Panels 51" x 59 1/4" (Shingles overhanging roof ply on 1 side) 2 - Middle Roof Panels 45 1/2" x 59 1/4" (Shingles flush with roof ply both sides) 16 - Filler Shingles - Long 4 - Filler Shingles - Short 22 - Cedar Roof Ridge Caps (1 Ridge Cap shorter for center of roof)	D1 - D12		

Note: Trim and Skirting pieces are graded with the best face being rough sawn.
 Rough sawn cedar is much easier to paint and stain.

12x8 CABANA

Hardware Kit - BASE KIT (Provided)

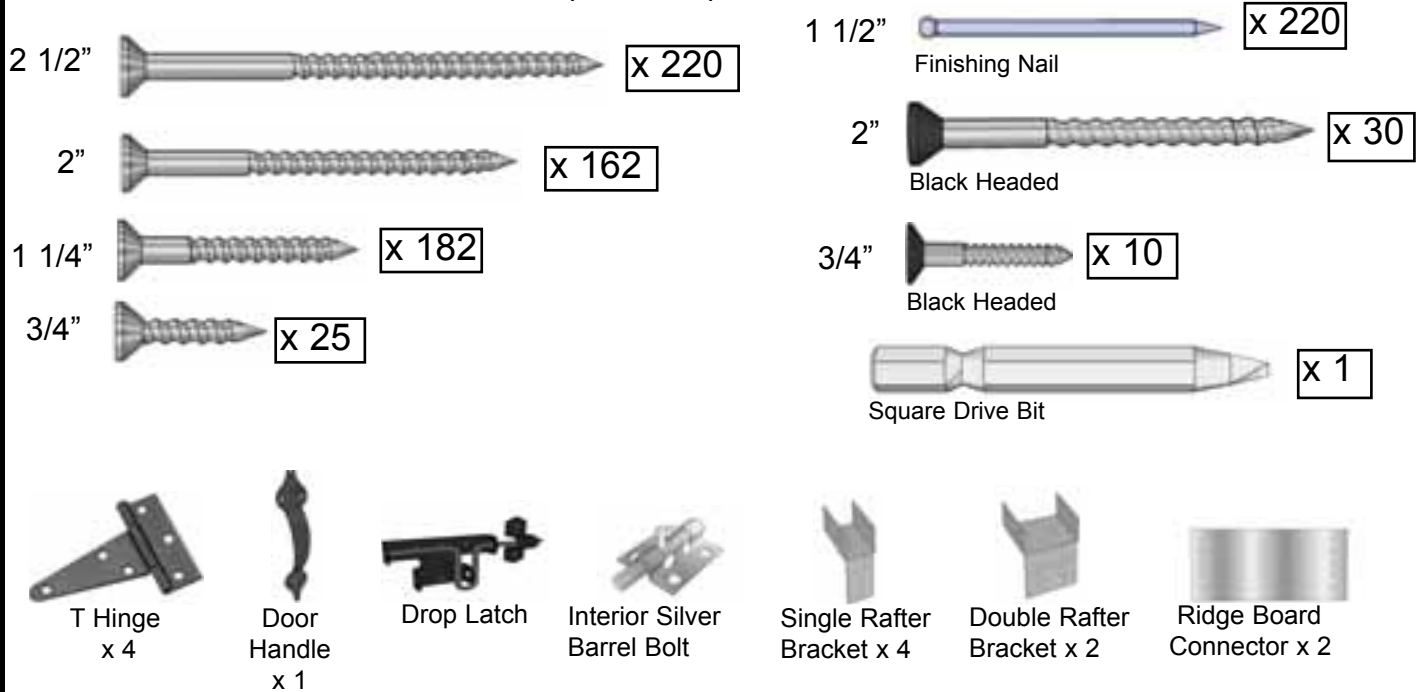

Hardware Kit - CEDAR ROOF (Provided)

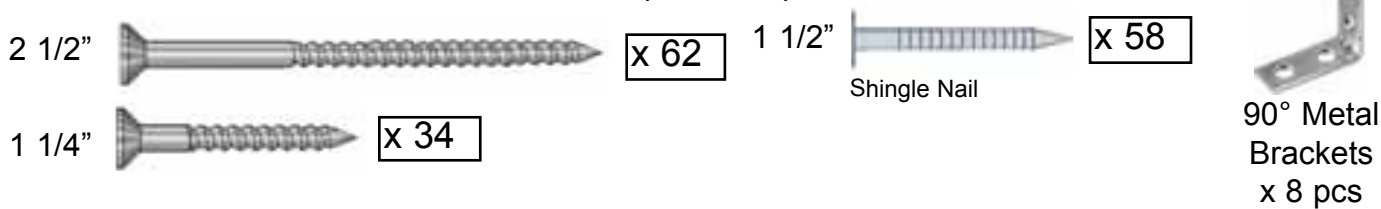

Hardware Kit - METAL ROOF (Provided)



Hardware Kit - PLYWOOD ROOF (Provided)

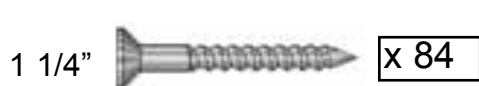

Tools Required (Not Provided)



Hammer



Screw Gun/Drill



Tape Measure



Wood Clamp



3/8" Wrench



Level



Pliers



Ladder



1/8" & 3/8" Drill Bits



Utility Knife

Safety Equipment Required (Not Provided)



Safety Glasses



Work Gloves

Assembly Manual shows instructions for the 12x8 Cabana and three different roof options. Please proceed to correct roof section depending on your selected roof type after rafter installation.



Regular Maintenance & Tips to Prolong the Life of Your Shed.

Before/During Assembly:

- 1.) Paint each face and edge of your plywood floor with a latex exterior paint.
- 2.) Caulk wall seams if gaps appear.
- 3.) Caulk around window framing (if applicable).
- 4.) Caulk perimeter between floor plywood and bottom wall plate.
- 5.) Caulk channels in lap siding at the top of your door above the trim, just a drop in each channel.
- 6.) Caulk edge of door threshold (if applicable).
- 7.) Optional: Install a Sill Gasket between floor runners and foundation.
- 8.) Optional: Install an 8" strip of roofing paper below Cedar Ridge Caps for Cedar Roof Sheds.

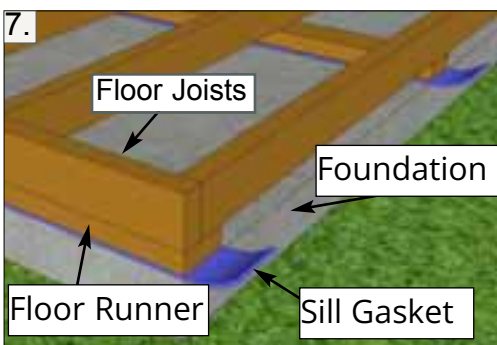
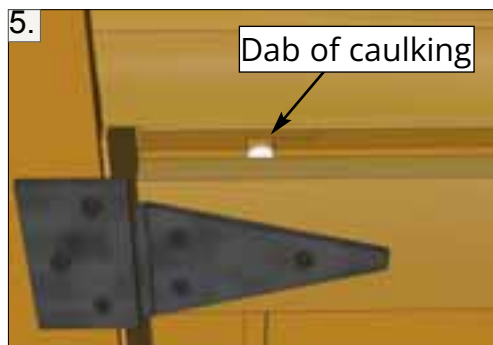
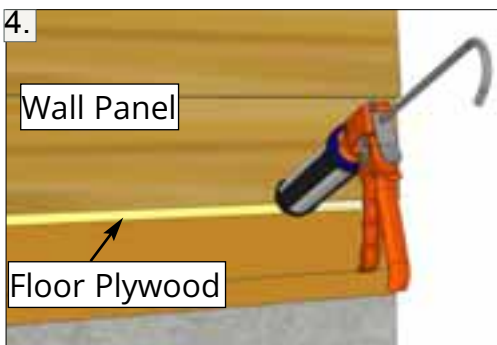
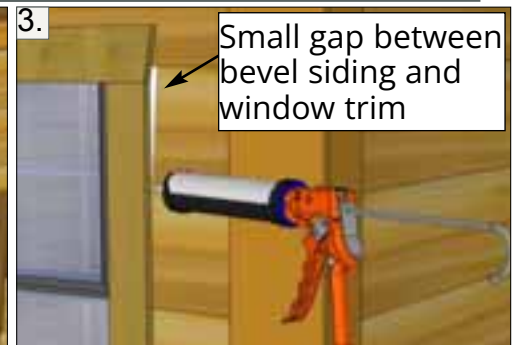

Routine Maintenance:

- Routinely check all fasteners are tight (ex. Door Hinges, Nails)
- Brush off dirt from walls.
- Brush off snow from roof regularly.
- Routinely remove needles and leaves from roof.

Painting/Staining

- Your cedar shed, if left untreated, will weather to a silvery grey colour.
- Painting or staining your structure is highly recommended and will prolong the life of your shed.
- You do not need to wait to paint or stain your shed, the wood in your kit has been dried and can be stained or painted immediately.
- Consult your local paint store for the best paint or stain for cedar.
- Optional: stain the inside of your shed. (Note: this will remove the fresh cedar smell.)

A. Floor Section

Exploded view of all parts necessary to complete Floor Section. Identify all parts prior to starting. Note: Floor Footprint is 136 1/2" wide x 96" deep.

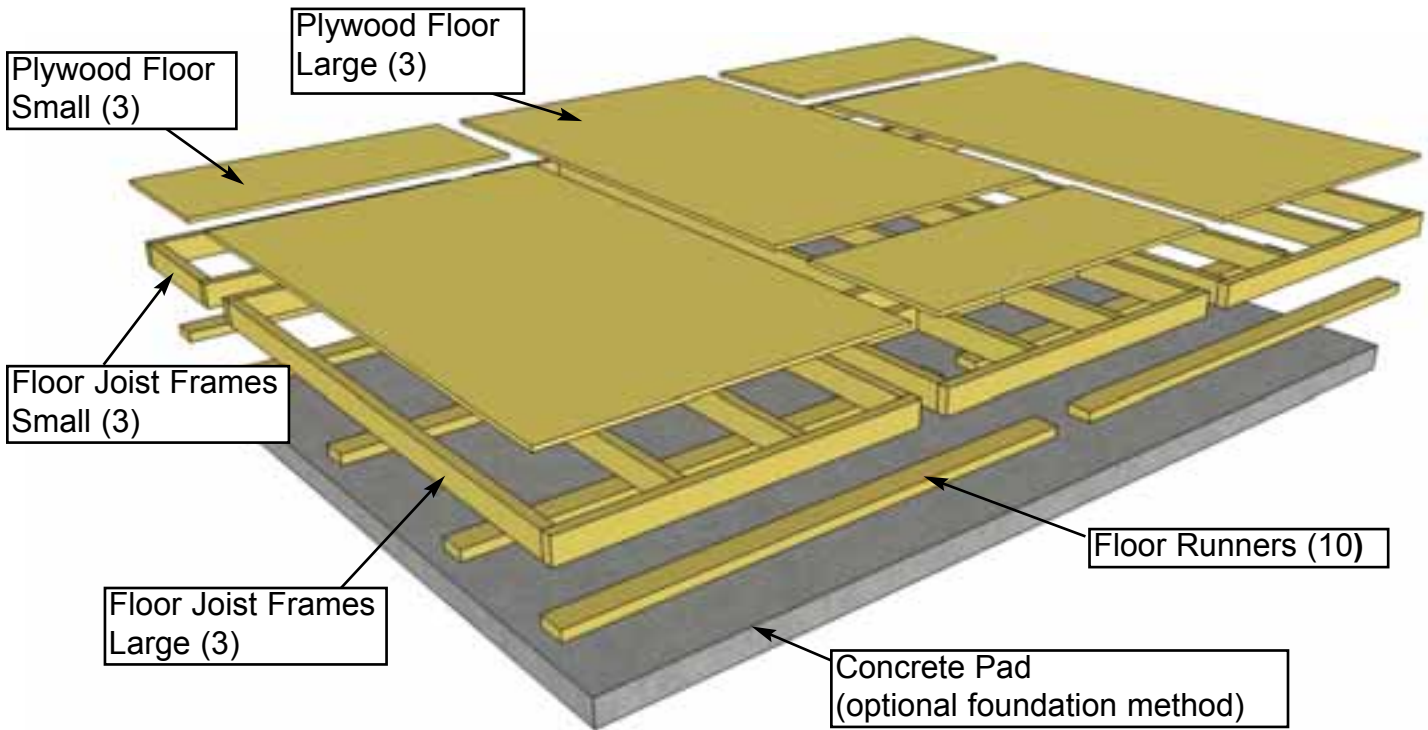

You can find the Square Drive Bit for the screws in with the Hardware Kit Bag.

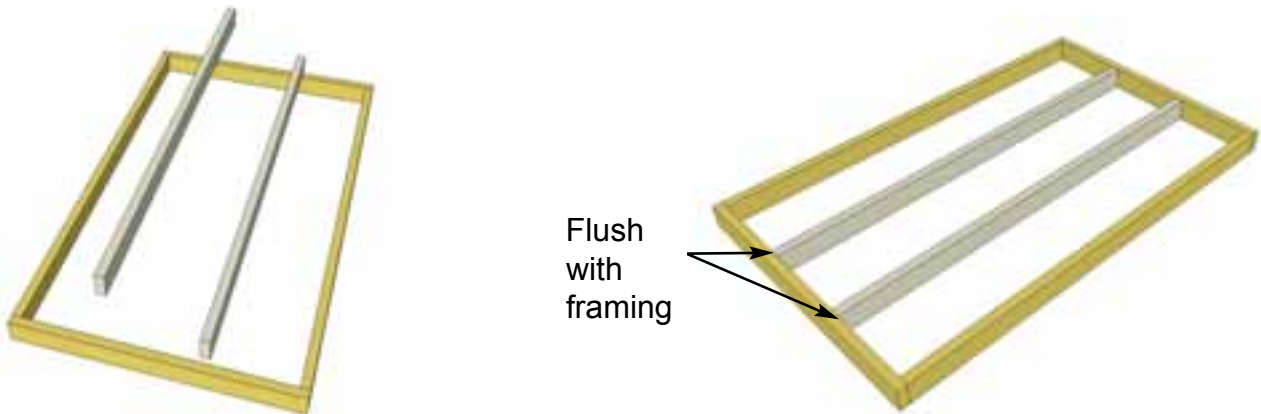

A1. Lay out Large Floor Joist Frame and 2 Floor Joists as illustrated above. Position Joists equally in Floor Joist Frame. Use Small Floor Joist Frame as a template to determine joist position. Position Joist so flush with framing.

Parts (Steps A1 - A6)	Hardware (Steps A1 - A6)
Floor Joists (1 1/2" x 3 1/2" x 71 7/8") x 6 Floor Joist Frames - Large (45 1/2" x 75") x 3 Floor Joist Frames - Small (45 1/2" x 21") x 3	2 1/2" Screws x 58 total

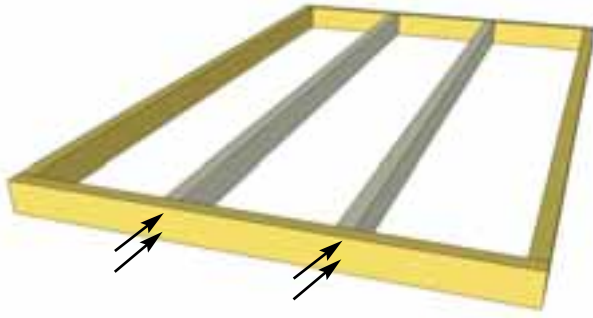

A2. When correctly positioned, attach each Joist with 4 - 2 1/2" screws (2 per end). You can find the Square Drive Screw Bit in the Hardware Kit Bag.

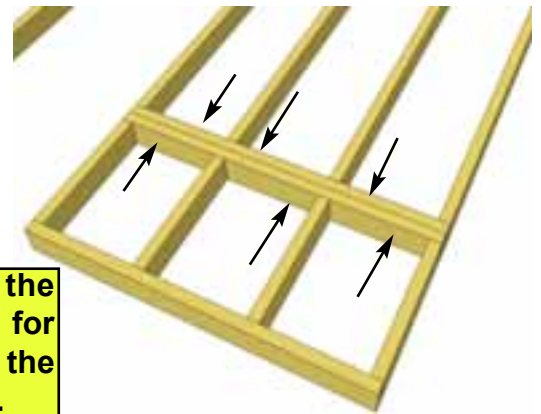
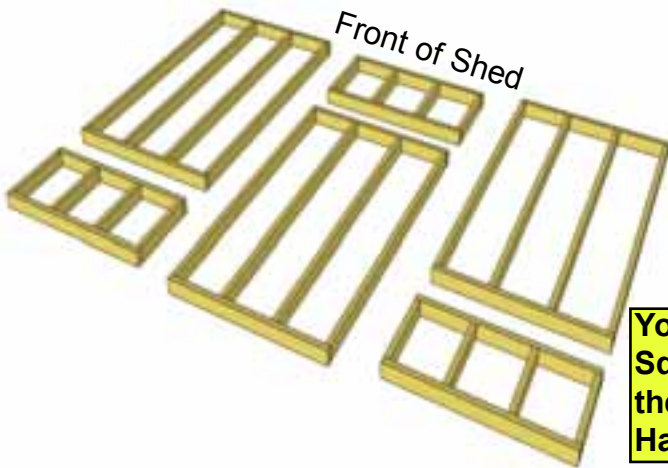

You can find the Square Drive Bit for the screws in with the Hardware Kit Bag.

A3. Lay out Floor Joist Frames as illustrated. There are 3 larger and 3 smaller Frame Sections. The Footprint for the floor when attached together will be 136 1/2" wide x 96" deep.

A4. Attach each large and small floor joist frame together with 6 - 2 1/2" Screws per section.

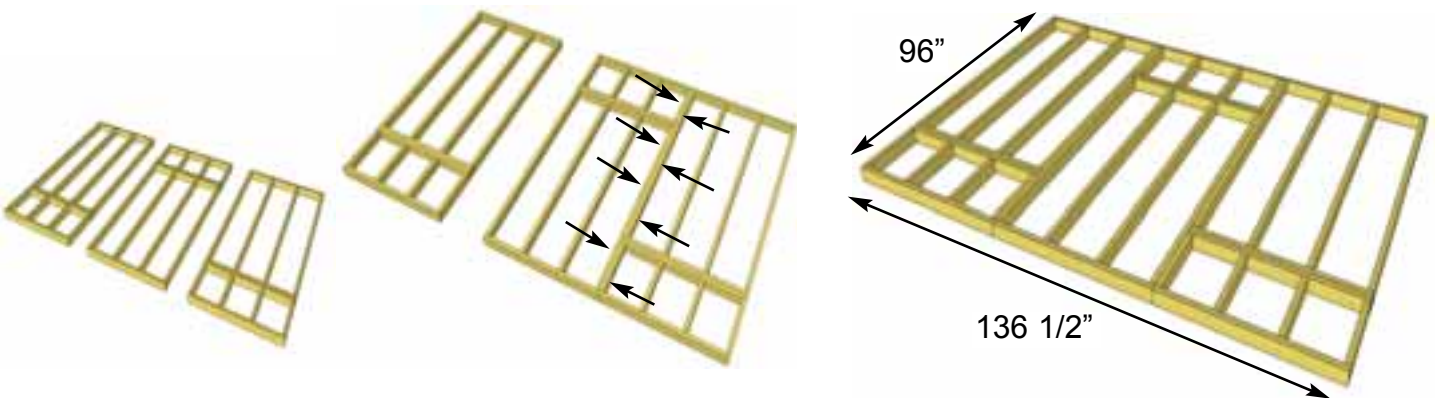

A5. Complete all large and small frame attachments. Screw each completed section together with 8 - 2 1/2" Screws.

A6. When completed, your floor footprint should be 136 1/2" wide x 96" deep.



A7. Attach **Floor Runners** to completed floor frame. There are 2 Floor Runners per 136 1/2" side and 5 completed Runners in total. Use 6 - 2 1/2" Screws per Runner.

<u>Parts (Steps A7 - A9)</u> Floor Runners (1 1/2" x 3 1/2" x 68 3/16") x 10	<u>Hardware (Steps A7 - A9)</u> 2 1/2" Screws x 60 total
---	---

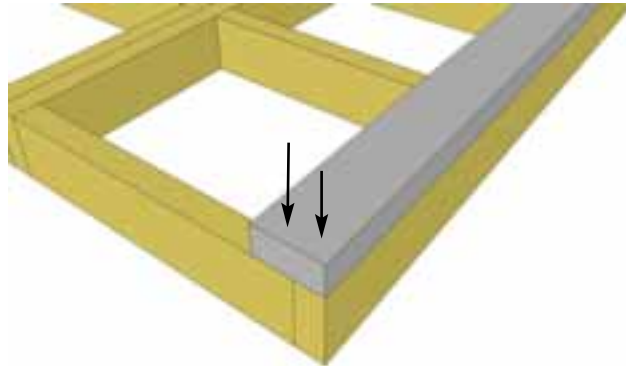

A8. Make sure Runners are flush with outside and front and rear floor framing but not overhanging.



Foundations

Note: The floor will be flipped over and the floor runners will sit on your foundation. It is important to note, that having a level foundation is critical. Choosing a foundation will vary between regions. Typical foundations can be concrete pads or patio stones positioned underneath the floor runners.

A9. Complete remaining Floor Runners.

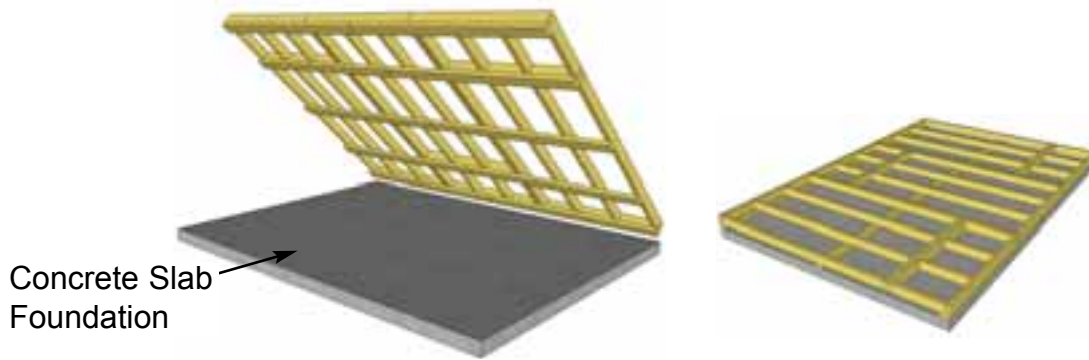

A10. With Floor Runners attached, carefully flip the floor over and place on your foundation. **Caution:** you will need 2 people to assist you. Be careful when laying floor down not to bend or twist floor. When in place, level floor completely.

Important - Make sure floor is level before moving on to wall section. Use a level to confirm, and shim floor joists as required.

Hint: Use a chalk line to mark location of floor joists to determine screw placement.

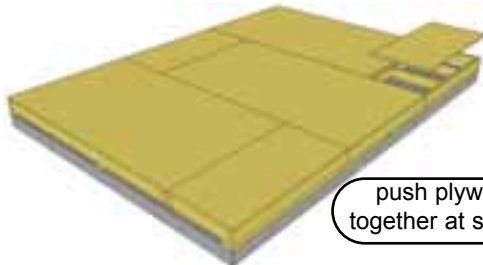
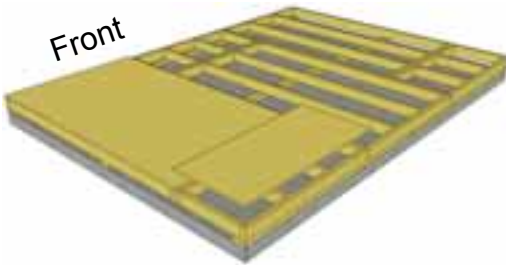

push plywood together at seams.

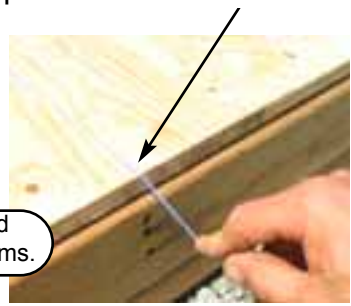

A11. Position all Large & Small Plywood Floor pieces on top of completed floor joists. Plywood will sit flush with outside of floor joist frame.

<p><u>Parts (Steps A11 - A12)</u> Plywood Floor - Large (45 3/8" x 74 7/8") x 3 Plywood Floor - Small (45 3/8" x 20 7/8") x 3</p>	<p><u>Hardware (Steps A11 - A12)</u> 1 1/4" Screws x 70 total (approx)</p>
---	---

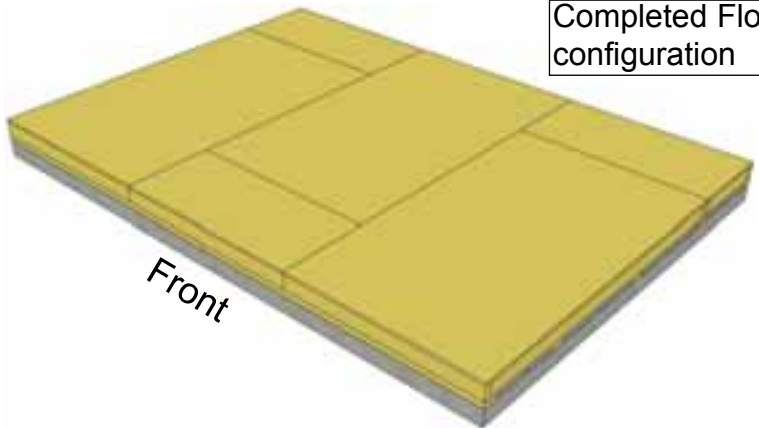
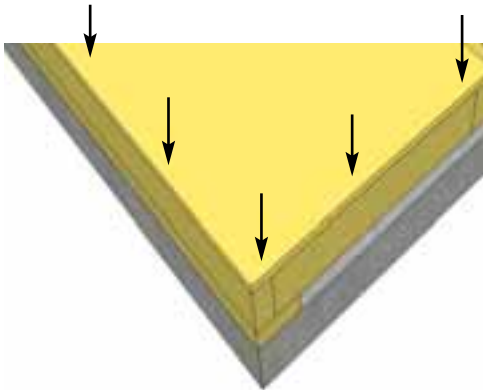

Completed Floor configuration

A12. With Plywood positioned correctly on floor framing, attach with 1 1/4" Screws. Use screws every 16".

B. Wall Section

Exploded view of all parts necessary to complete the Wall Section. Identify all parts prior to starting.

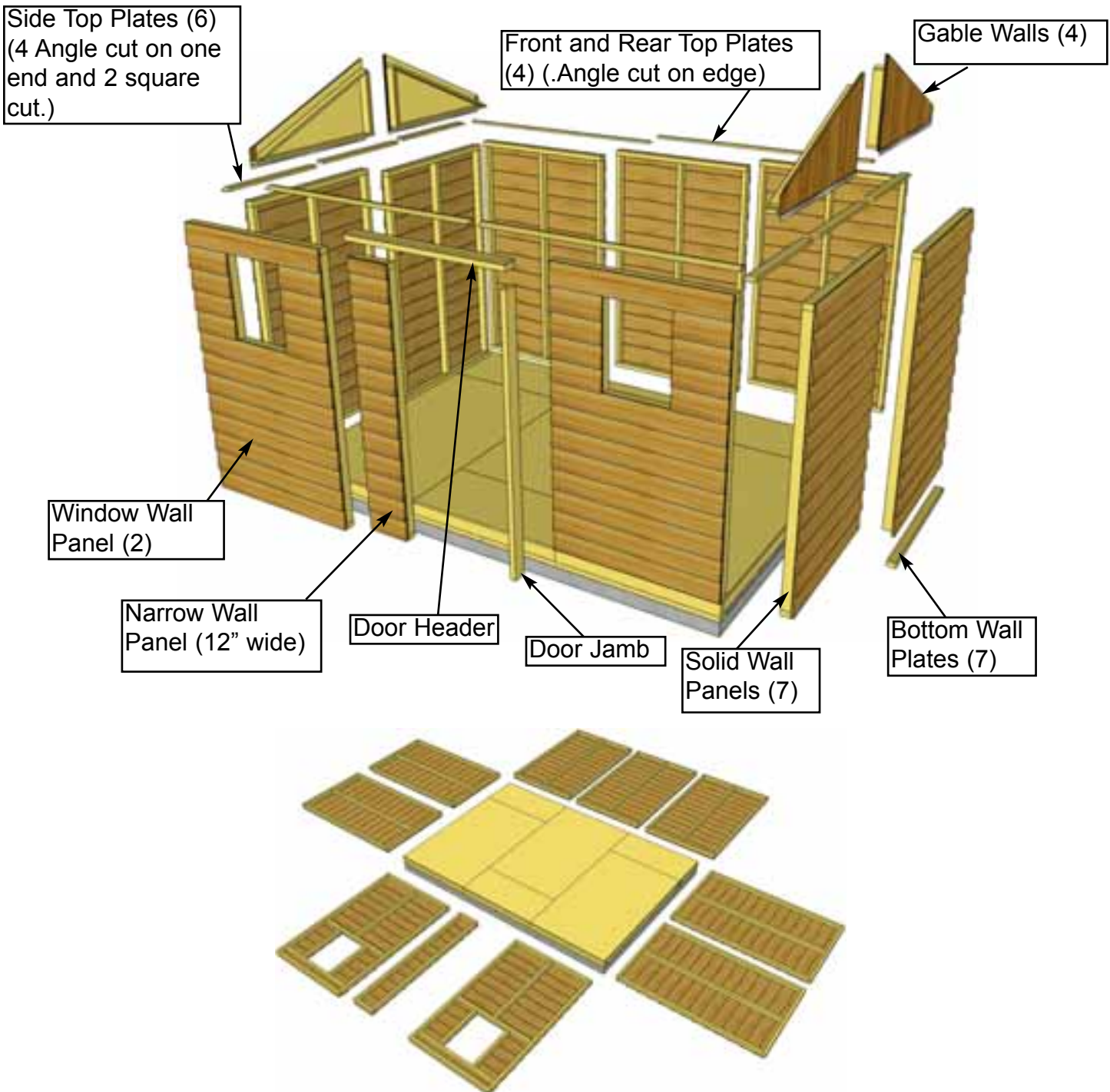

B1. Lay out all the wall panels and become familiar with their location. On Standard Kits, there are 2 Window Wall Panels, 7 Solid Wall Panels and 1 Narrow Wall Panel. Make sure to position panels right side up so water is directed away from and not into shed. Look at window wall panels to determine proper wall position to confirm.

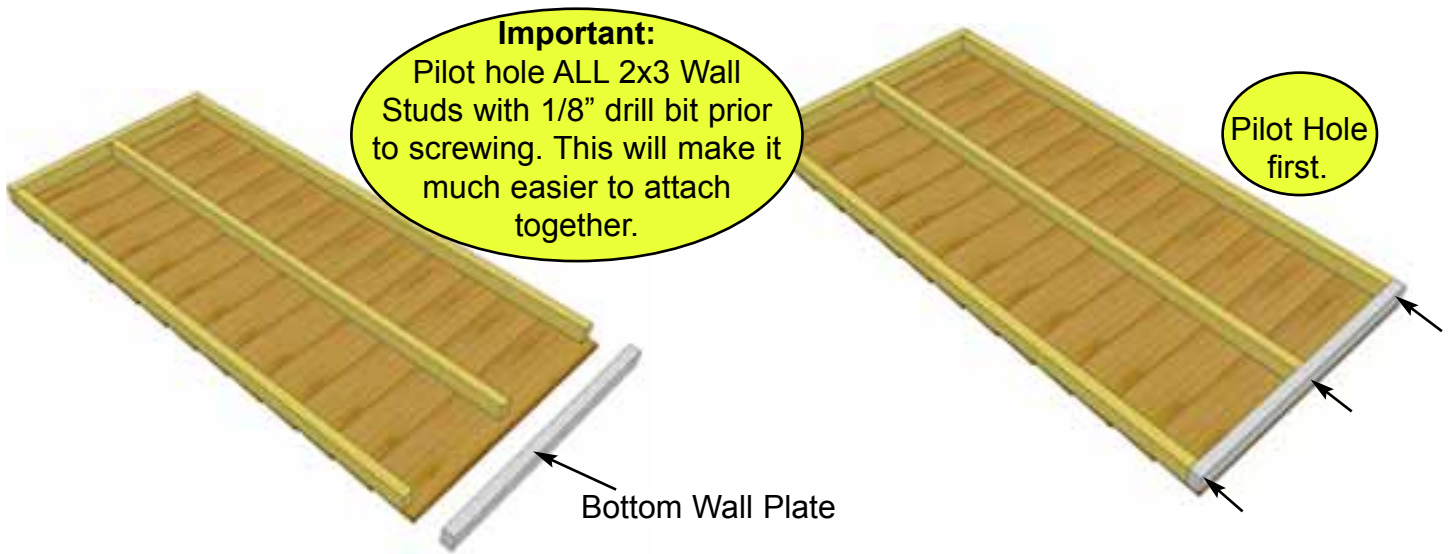

B2. For each Solid Wall Panel , carefully lay panel face down. Position and attach a Bottom Wall Plate to bottom of wall studs of each wall panel with 3 - 2 1/2" Screws. Position so plates are flush with framing.	<u>Parts</u> Solid Wall Panels (45 1/2" x 75") x 7 Bottom Wall Plates (1 1/2" x 2 1/2" x 45 1/2") x 7	<u>Hardware</u> 2 1/2" Screws x 21 total

Important - Make sure all walls are aligned in their upright position. If not, water may leak into your shed. Unsure if panel is facing up or down? Compare solid wall siding to window wall siding and match orientation.

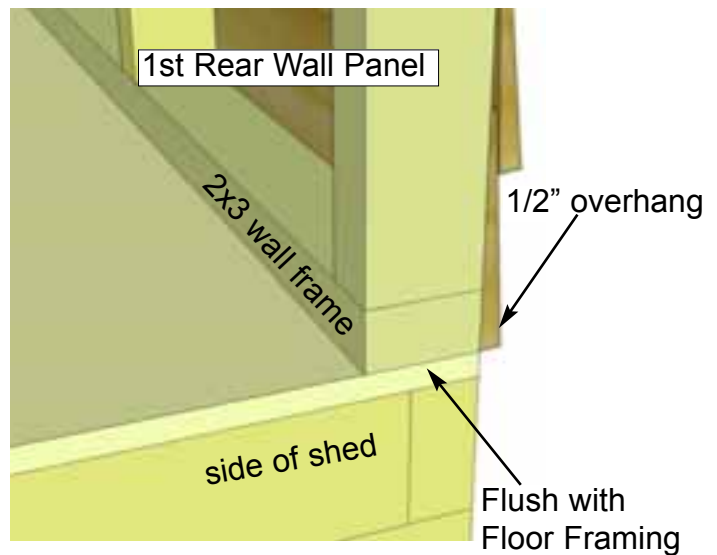
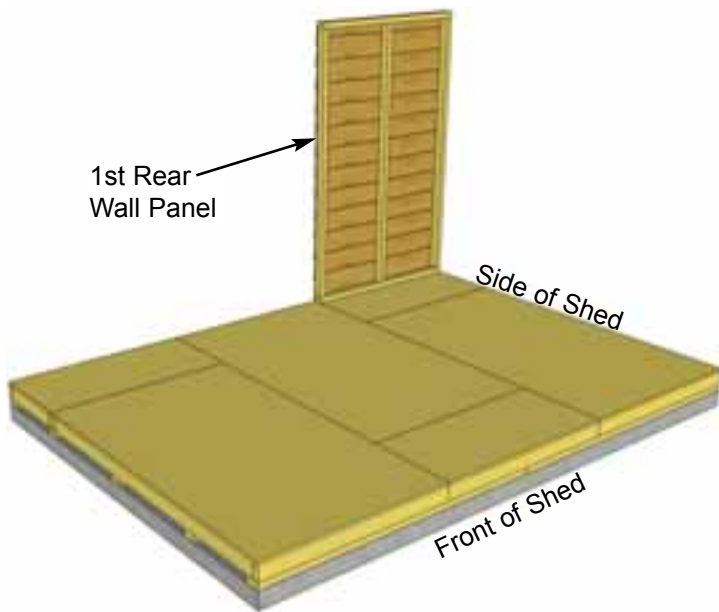

B3. Starting at Rear Corner, position a Solid Wall Panel on top of plywood floor. The Wall Panel bottom framing will sit flush with plywood. Wall siding will overhang the floor. The Rear Wall panels will sit flush at the end of the plywood floor with the side wall panels sandwiched between them **Note:** Siding will overhang the floor by approximately 1/2".

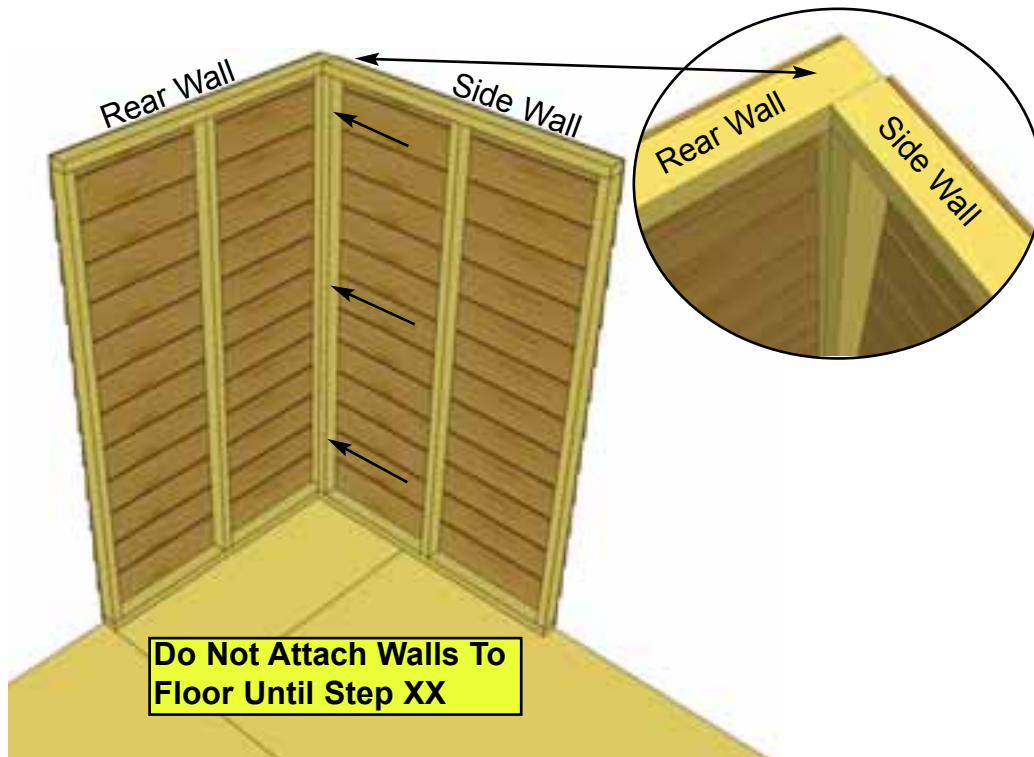

B4. Position side solid wall into place on plywood floor. Butt both vertical wall studs of side and rear walls together and attach with 3 - 2 1/2" Screws. Screw at the bottom, middle and top of stud to secure properly.

Hardware (Steps B4 - B6)
 2 1/2" Screws
 x 18 total

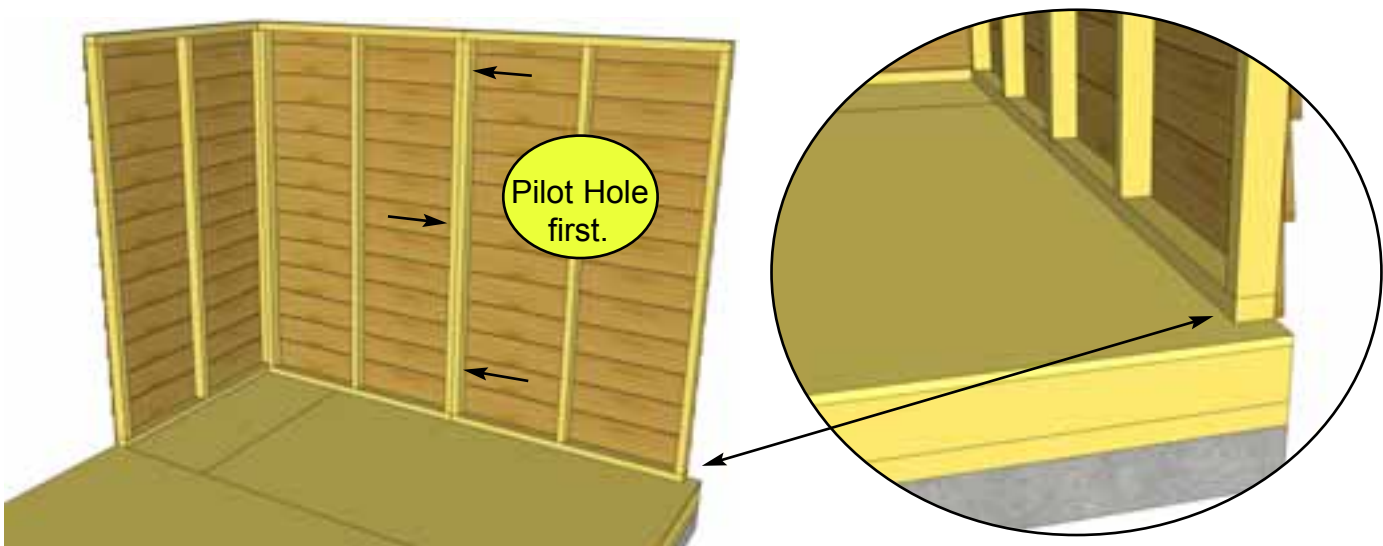

B5. With the corner wall attachment complete, position a second Side Wall panel in place so bottom 2x3 wall framing is sitting flush with outside floor joists and plywood floor. Wall siding should overhang floor by approximately 1/2". When positioned correctly, attach both Side Wall panel studs together as shown.

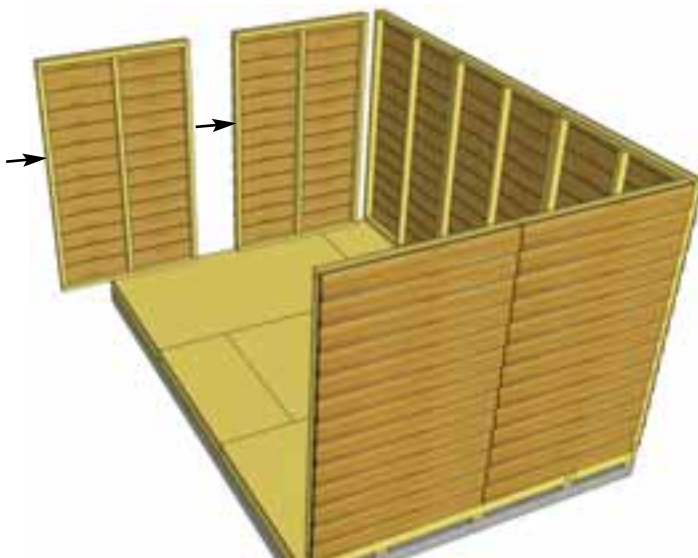
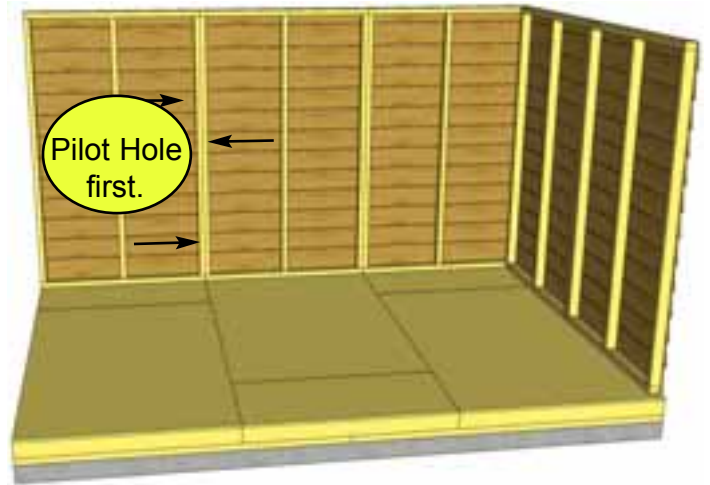
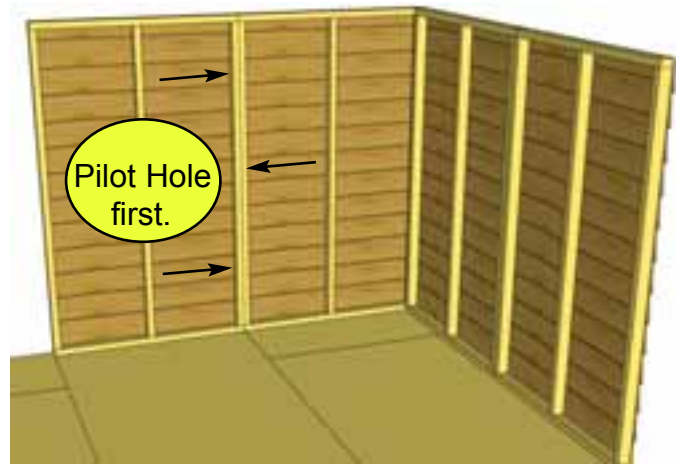

B6. Complete all Side and Rear Wall attachments as per Steps B4 - B5.

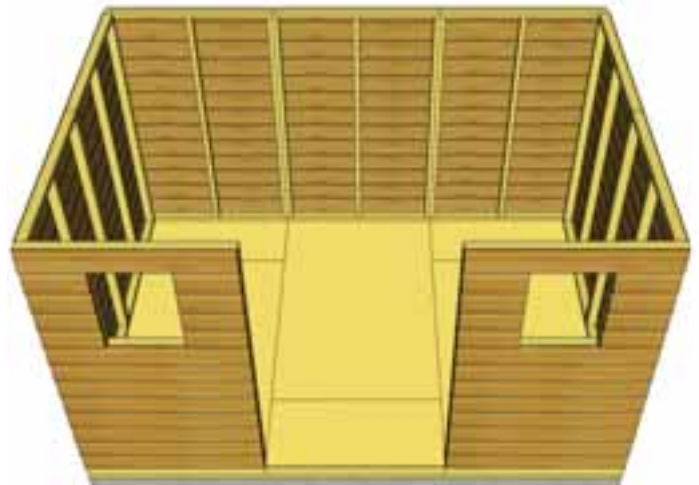
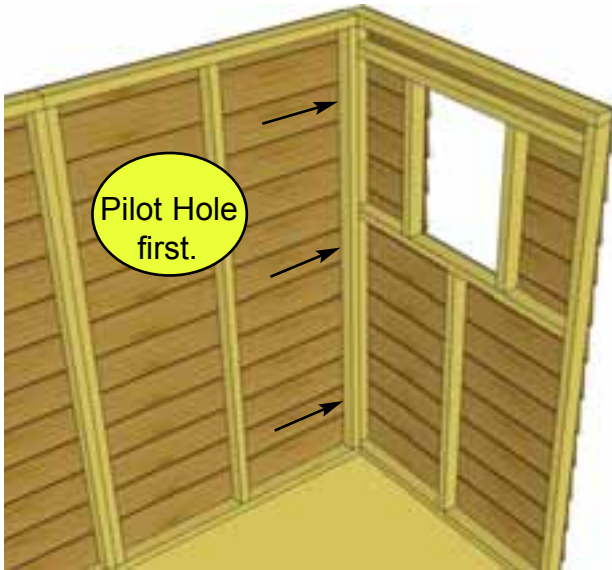
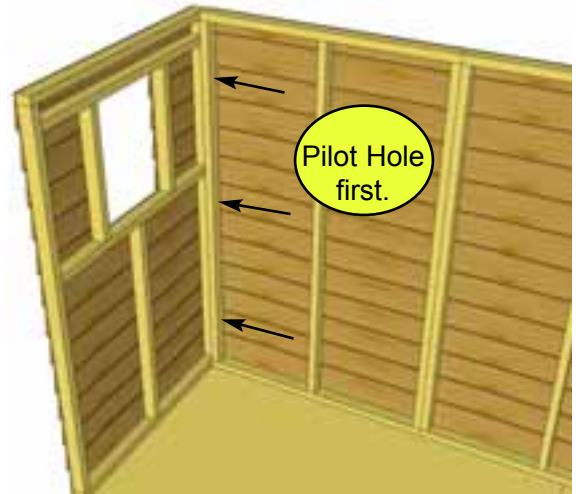
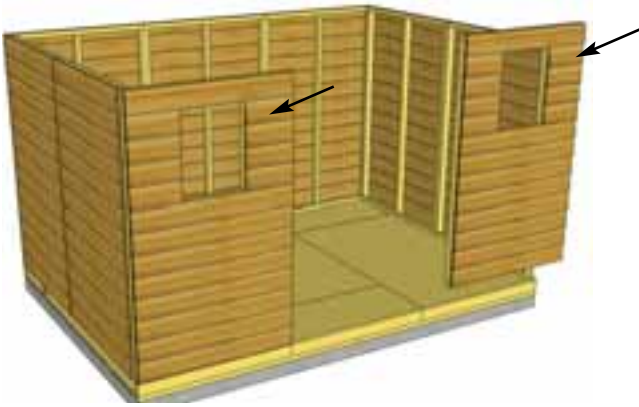

B7. Position and attach both **Window Walls** as per **Steps B4 - B6.**

Parts
Window Walls
 (45 1/2" x 75") x 2

Hardware
2 1/2" Screws
 x 6 total

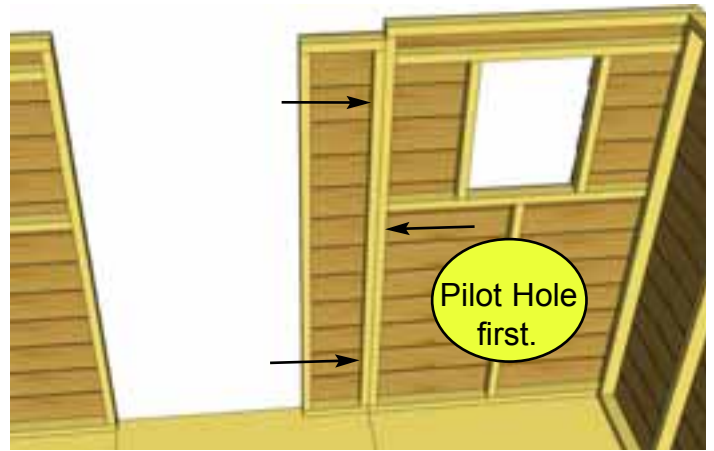
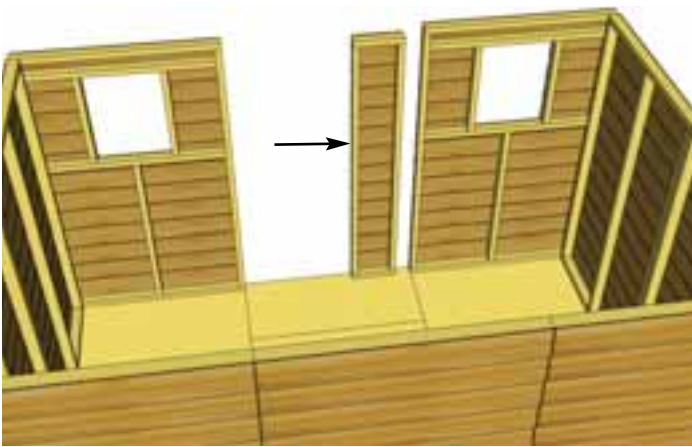

B8. Position and attach **Narrow Wall** as per **Steps B4 - B6.**

Parts
Narrow Wall
 (12" x 73") x 1

Hardware
2 1/2" Screws
 x 3 total

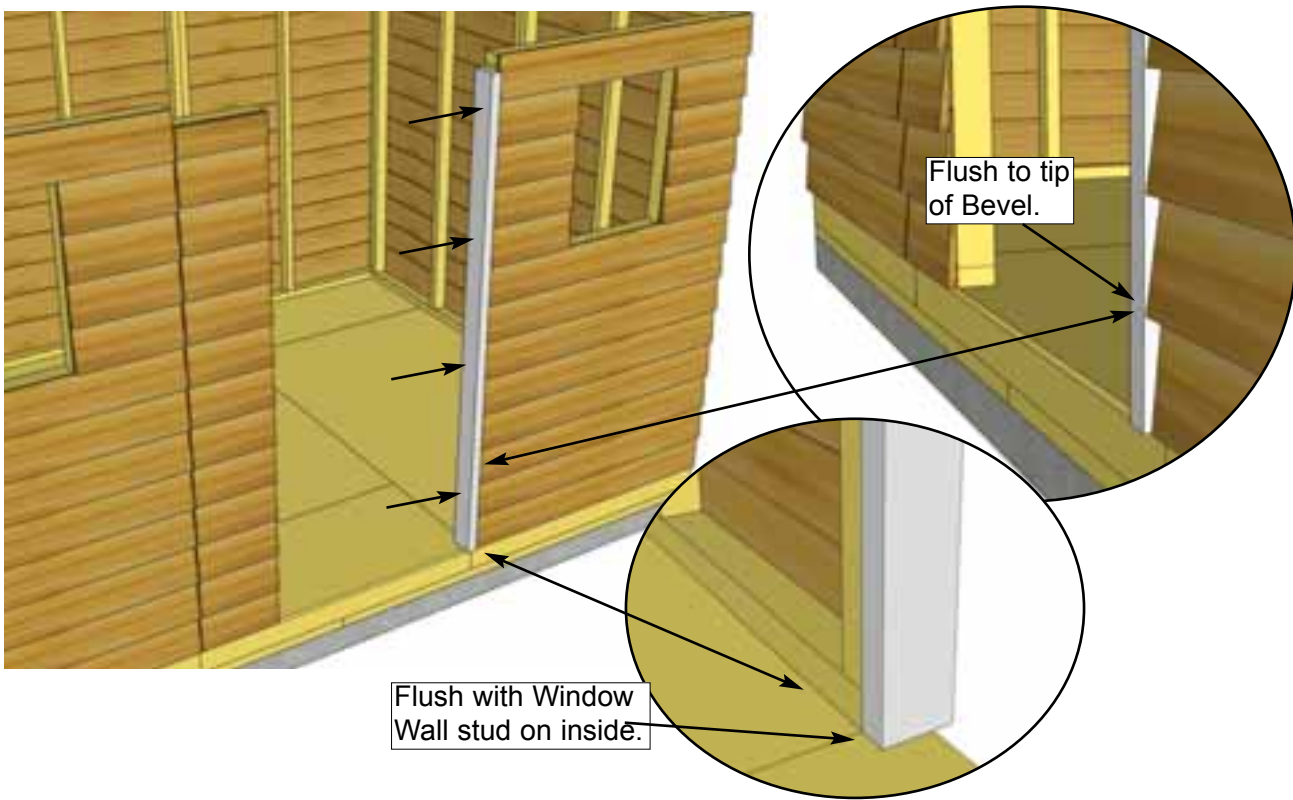

B9. Attach **Vertical Door Jamb** to Window Wall stud in door opening with 4 - 2 1/2" Screws. Position so Jamb is flush with tip of bevel siding on front Window Walls.

<u>Parts</u> Vertical Door Jamb (1 1/2" x 3 1/2" x 73") x 1	<u>Hardware</u> 2 1/2" Screws x 4 total
--	--

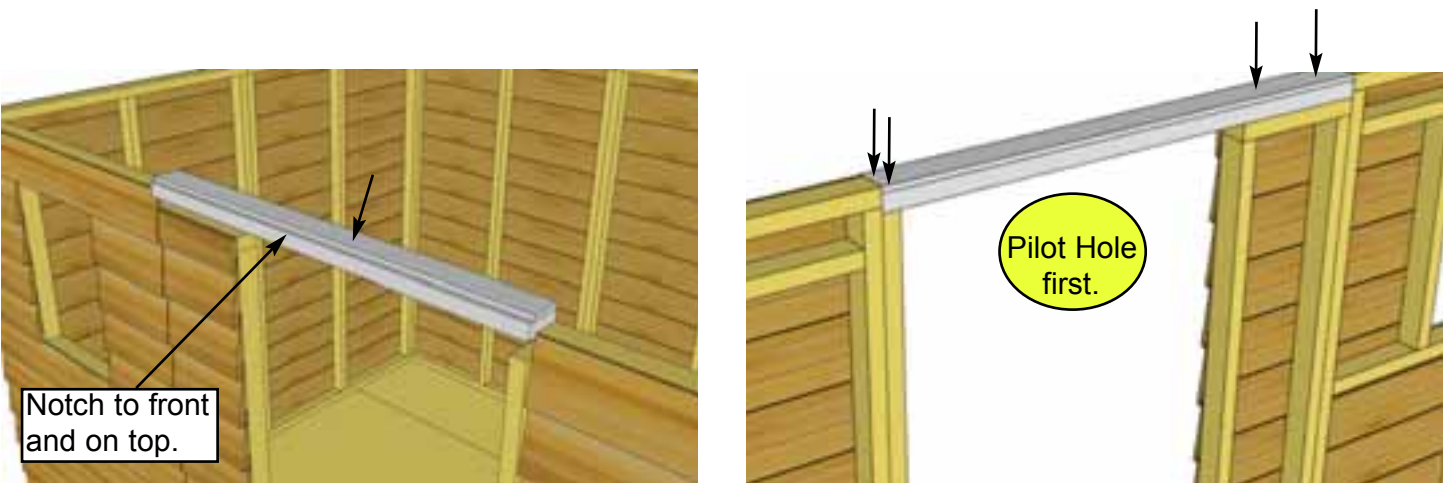

B10. Attach **Door Header** to Vertical Door Jamb and Narrow Wall with 2 - 2 1/2" Screws per side. Header is 3 1/2" wide at bottom and has a 1/2" thick x 3" wide strip of wood stapled to the top creating a notch or dado effect. This notch needs to be positioned on the top facing the front. The notch is necessary as the roof panel may hang up on the Header and must sit flush on the rafter tops when attached. **Pre-drill to prevent splitting!**

<u>Parts</u> Door Header (2" x 3 1/2" x 45 1/2") x 1	<u>Hardware</u> 2 1/2" Screws x 4 total
---	--

Advice: Prior to fastening walls and installing rafters, take time to confirm your walls are level, square and plumb.

Measure diagonal at top and bottom of walls corner-to-corner. This should be approximately 159 7/8". More importantly, if measurements are not within 1/4", your walls are not square. Adjusting now will make it easier to install roof section.

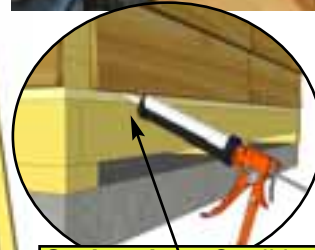
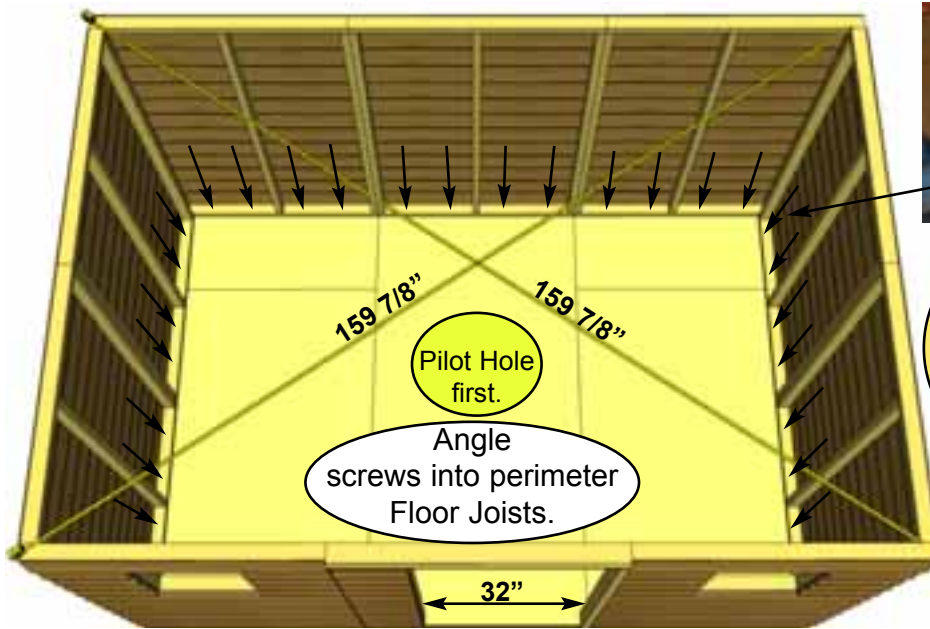

Optional Caulking seams will help prevent moisture from entering your shed. **Caulking not included in kit.**

B11. When all walls are attached together, check alignment with the floor. Bottom of wall frames should sit flush with outside of floor framing, with siding overhanging by approximately 1/2". Confirm 32" wide door opening at bottom. When positioned correctly, fasten Bottom Wall Plates to floor using 4 - 2 1/2" Screws per wall panel and 2 - 2 1/2" per Narrow wall panel

Hardware
2 1/2" Screws
x 38 total

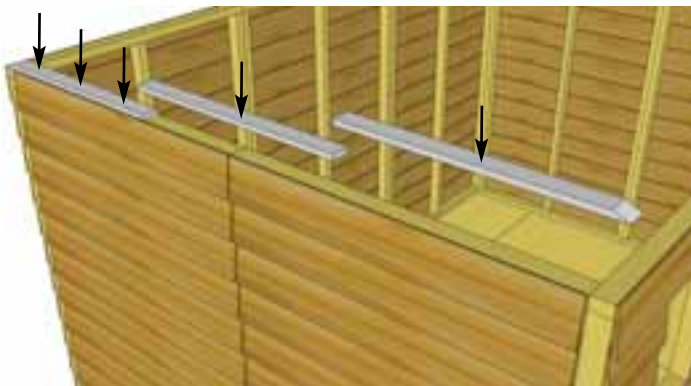

B12. Position **Side Top Plates** (one side only) on top of wall studs so they are flush on the inside. There are 3 Side Top Plate pieces per side (2 angle cut on one end and one straight cut - both ends). Together, the plates should be centered evenly on the wall left to right. Attach by screwing down into top wall framing with 3 - 2" Screws per plate.

Parts (Steps B12 - B13)

Side Wall Top Plates - 4 Angle Cut End, 2 Straight Cut
(3/4" x 2 1/2" x 32") x 6

Front & Rear Wall Top Plates - Angle Cut Edge
(3/4" x 2 1/2" x 65 3/4") x 4

Hardware (Steps B12 - B13)

2" Screws
x 34 total

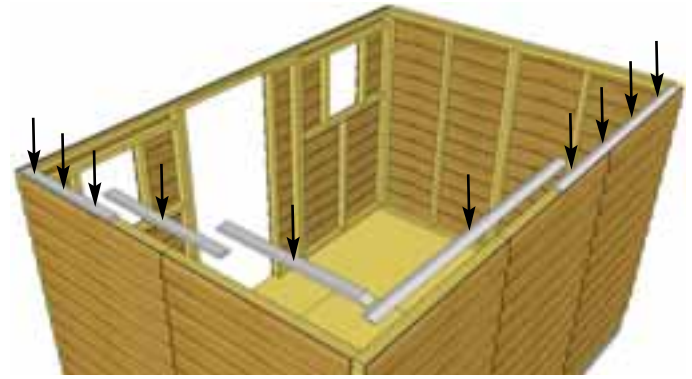
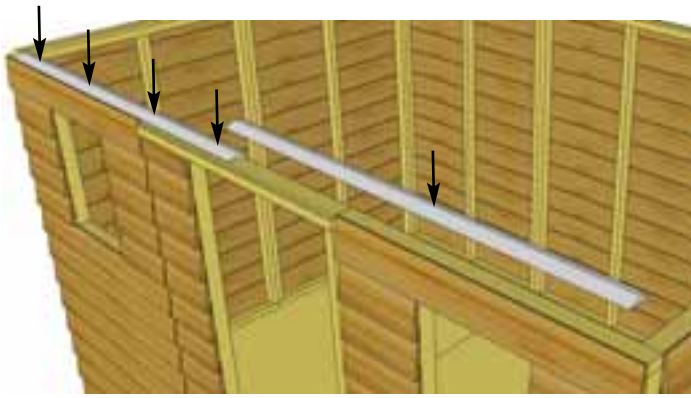

B13. Next, attach the **Front Top Plates**. The Front and Rear Top Plates are angle cut down the length. Once again, position Top Plates on wall frame so they are flush. Front and Rear Top Plates will fit between Side Top Plates. Attach with **4 - 2" Screws** per plate. Complete all other **Side & Rear Top Plate** attachments the same.

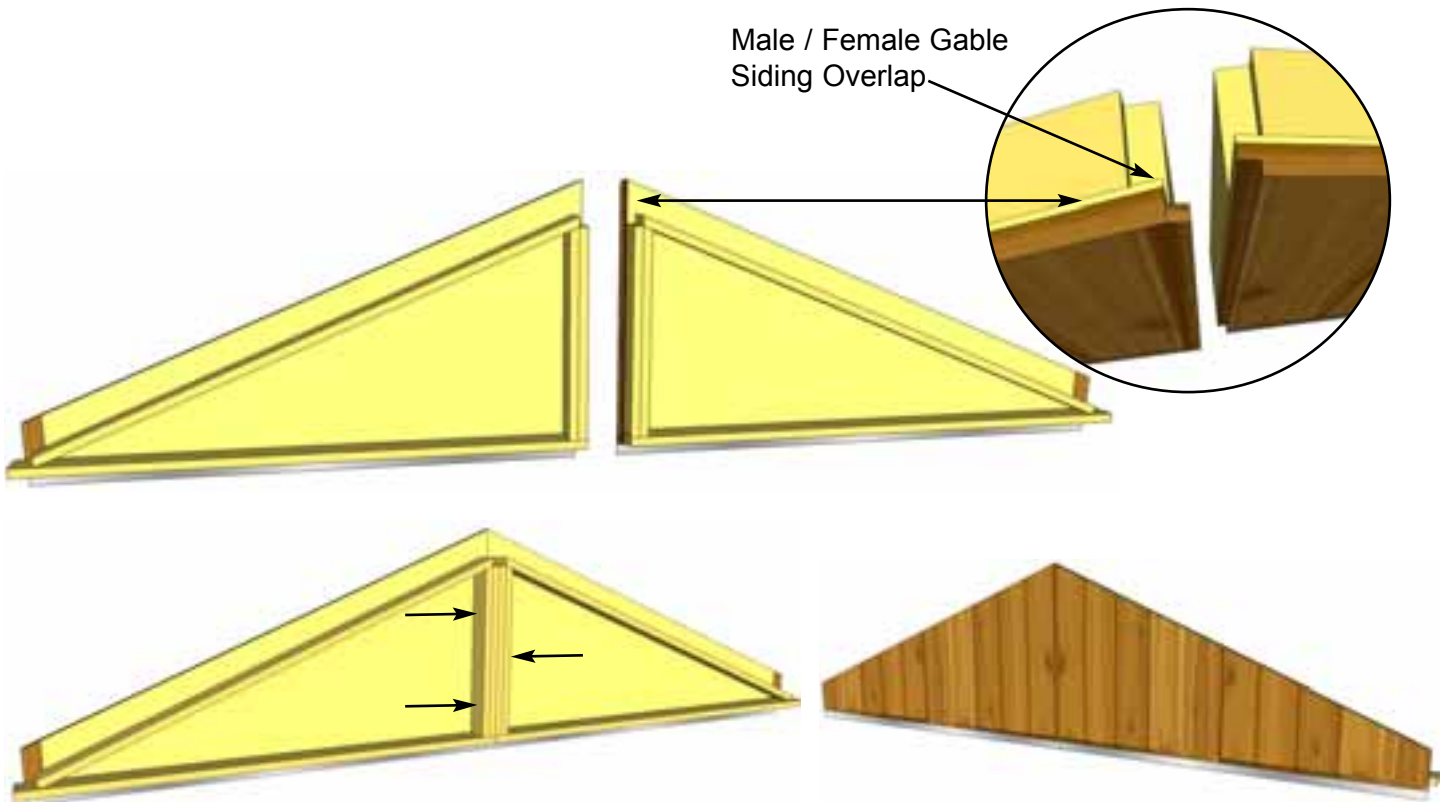

B14. Locate **Triangular Gable Half Walls** for both sides of the shed. Align framing and wall siding lap together. Screw center wall framing of each piece together with **3 - 2 1/2" Screws**.
Note: Prior to attaching, try each combination of Gables for best fit.

<u>Parts</u> Triangular Gable Half Walls x 4	<u>Hardware</u> 2 1/2" Screws x 6 total
---	--

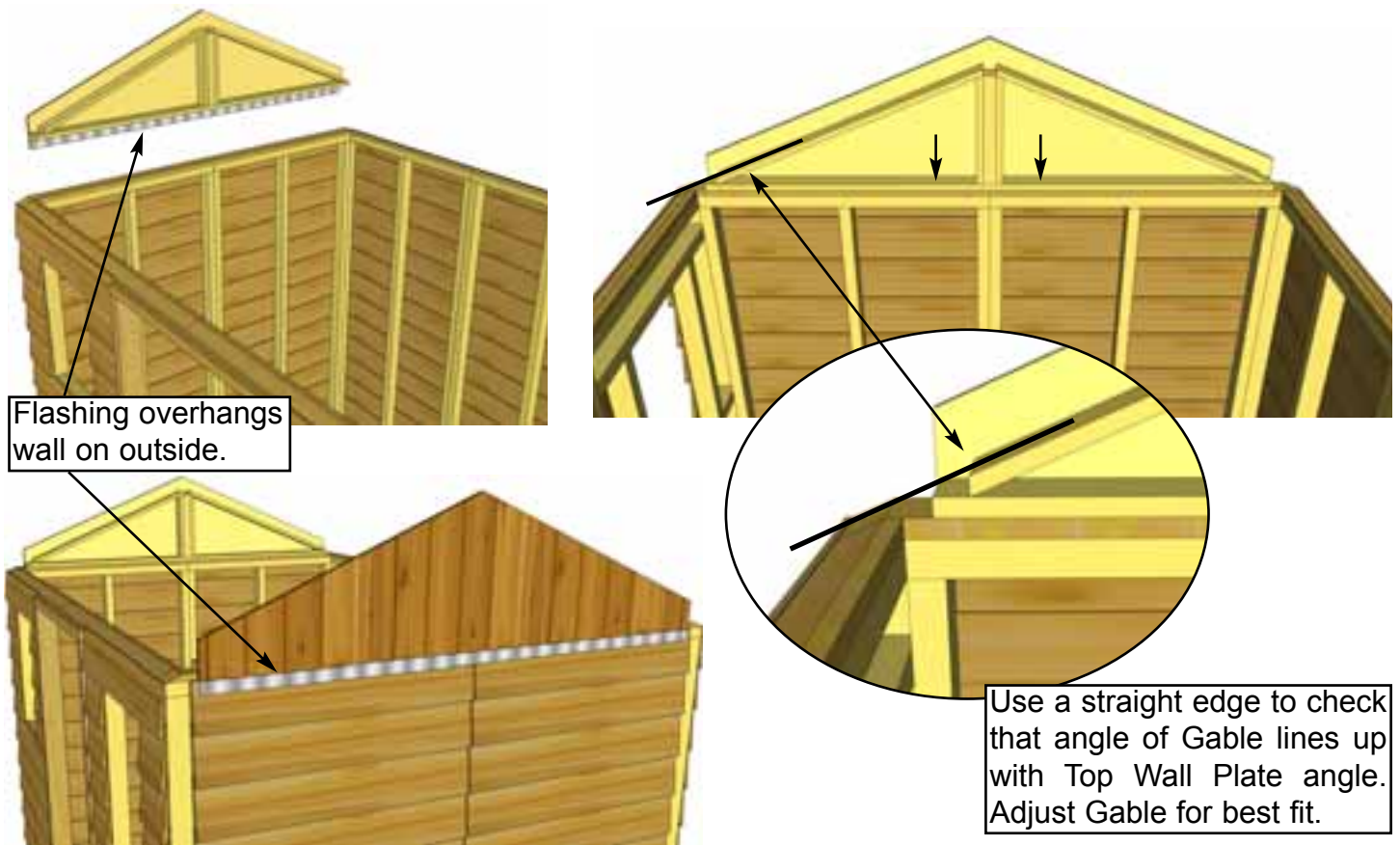

B15. Place completed Gable section so framing sits flush with the inside of the Top Wall Plate. It should also be centered side-to-side on the Top Wall Plate. Gable Flashing overhangs wall on the outside. Temporarily attach to Gables and Top Wall Plate with 2 - 2" Screws. Gables may need slight adjustment in **Step C10** when attachment will be completed with an additional 6 Screws. Screw from the bottom of Gable framing down into Top Wall Plate and Wall Framing. Complete Gable positioning and attachment on the other side.
Hint: Use a straight edge to check the angle of the Gable framing and Top Plate. Both angles should line up (see diagram above).

Hardware
 2" Screws x 4 total

C. Rafter Section

**Exploded view of all parts necessary to complete the Roof Section.
Identify all parts prior to starting.**

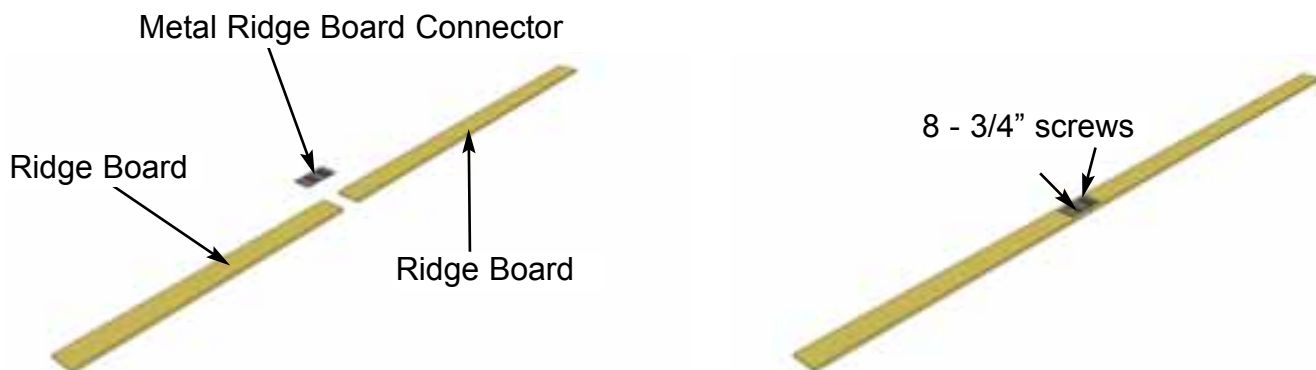
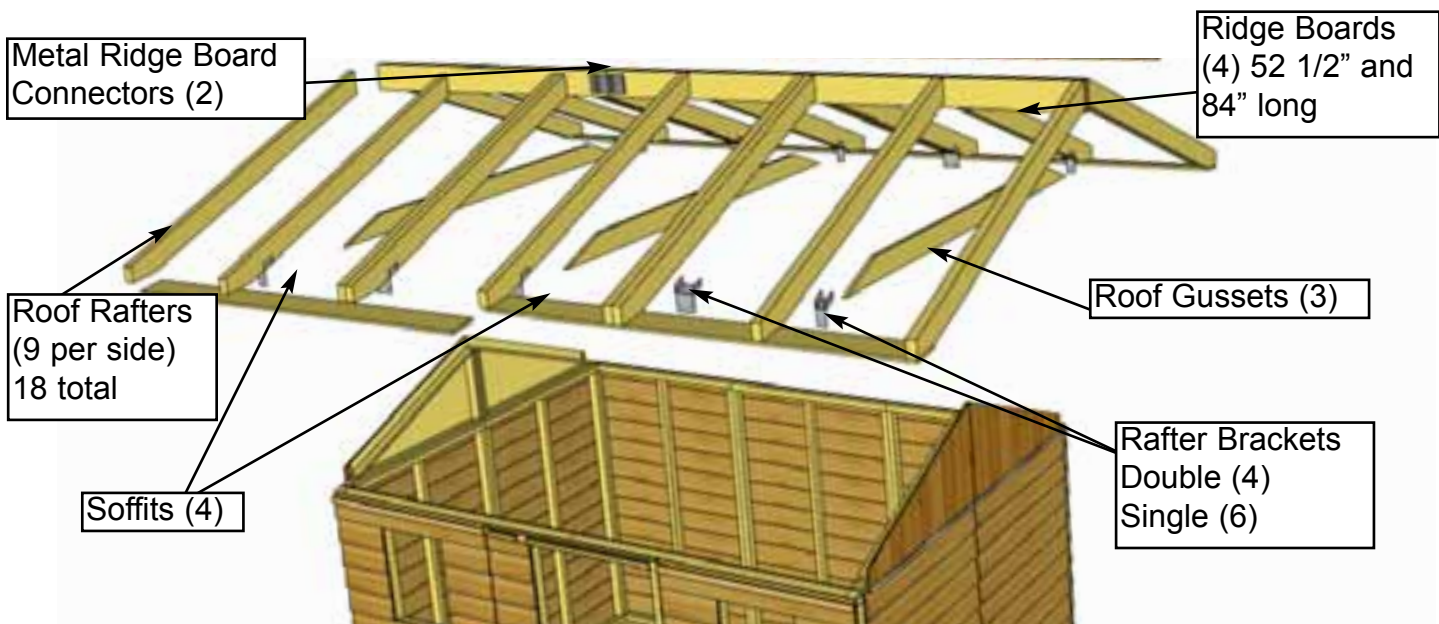

C1. Locate (1 each) Long & Short Ridge Boards and attach together with a metal Ridge Board Connector using 8 - 3/4" Screws. Total Length when connected is 136 1/2". Connect other set of Ridge Boards the same. Position metal Ridge Board Connector evenly on Ridge Boards.

Parts	Hardware
Ridge Boards - Long (3/4" x 4 1/2" x 84") x 2	3/4" Screws x 16 total
Ridge Boards - Short (3/4" x 4 1/2" x 52 1/2") x 2	Ridge Board Connector x 2 total

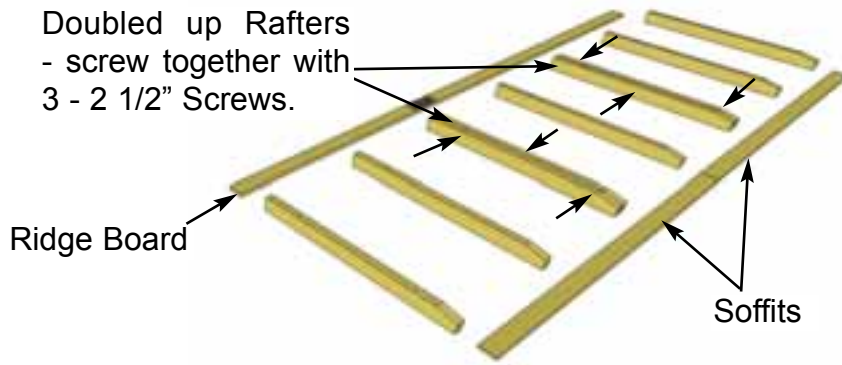

C2. Locate 9 Rafters, 2 Soffits and a completed Ridge Board. Lay out on level ground as shown. Double up Rafters as illustrated. Screw doubled up Rafters together with 3 - 2 1/2" Screws per piece.

Parts (Steps C2 - C4)	Hardware (Steps C2 - C4)
Rafters (1 1/2" x 3 1/2" x 56 1/2") x 18	2 1/2" Screws x 12 total
Soffits (1/2" x 4 1/2" x 68 1/4") x 4	1 1/4" Screws x 36 total
	2" Screws x 36 total

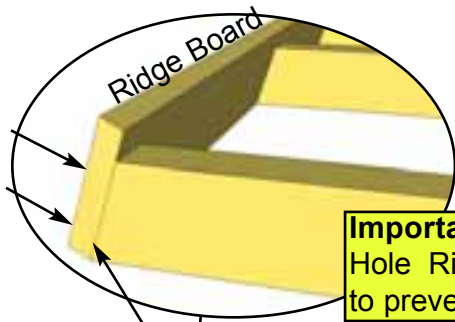

C3. Attach completed Ridge Board to ends of both outside Rafters with 2 - 2" Screws per end. Measure and position interior Rafters as illustrated below. When positioned correctly, attach Ridge Board to remaining Rafters with 2 - 2" Screws / Rafter end.

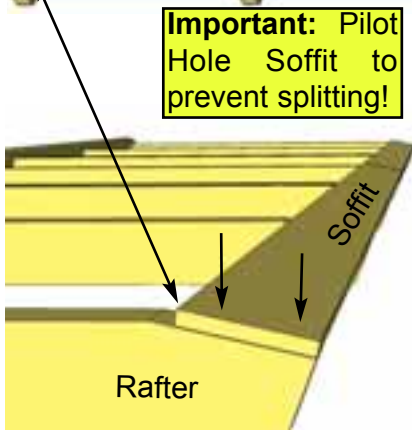
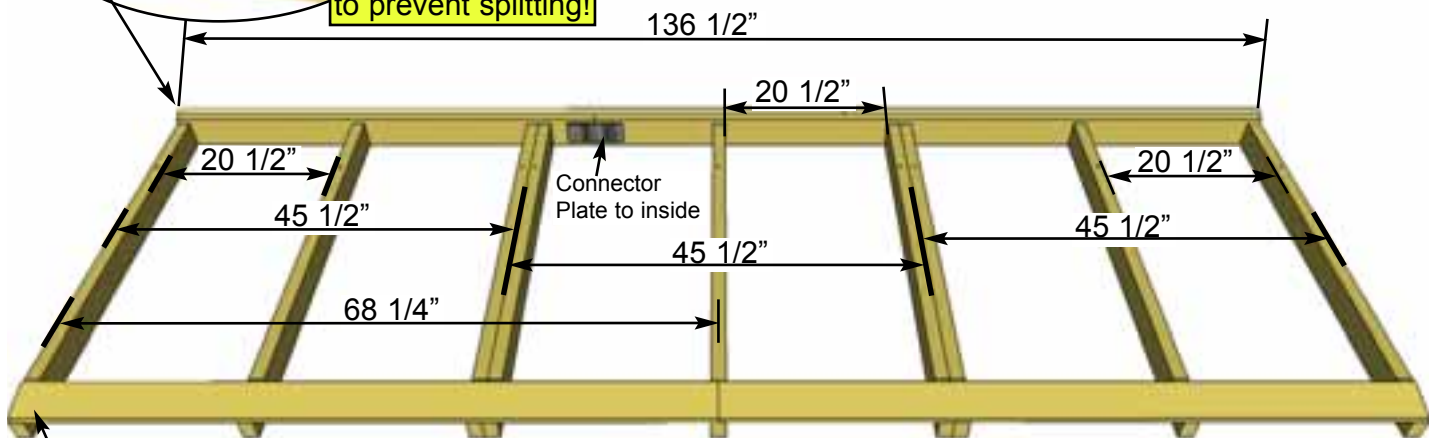

C4. Attach end of a Soffit flush to ends of outside rafters with 2 - 1 1/4" Screws per Rafter end. Drill pilot holes in Soffit to prevent splitting. Complete both outside Rafter / Soffit connections first. Measure and position interior Rafters as illustrated above. When positioned correctly, attach Soffit to remaining Rafters with 2 - 1 1/4" Screws per Rafter. Flip completed rafter section over. Complete 2nd Rafter section now as per the , but with the following exception - **When attaching Ridge Board to Rafter ends, make sure Metal Ridge Board Connector is positioned so offset to first Rafter Section. See Step C8 for illustration.**



C5. Flip Rafter Section over so Soffit is facing down. Starting with the rear Section, lift completed rafters up and place on gable framing.



C6. Slide Rafter Section up on gable framing until bottom of Ridge Board slips into gable notch.

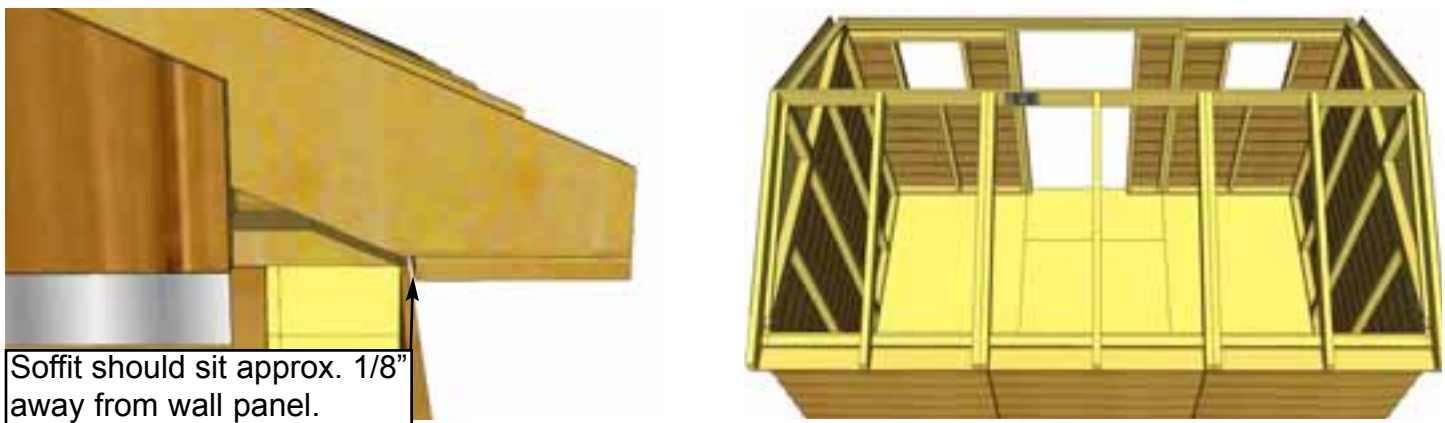

Soffit should sit approx. 1/8" away from wall panel.

C7. When Rafter Section is correctly positioned, outside rafters will sit equally on gable framing and Soffit will sit approximately 1/8" away from wall panels.

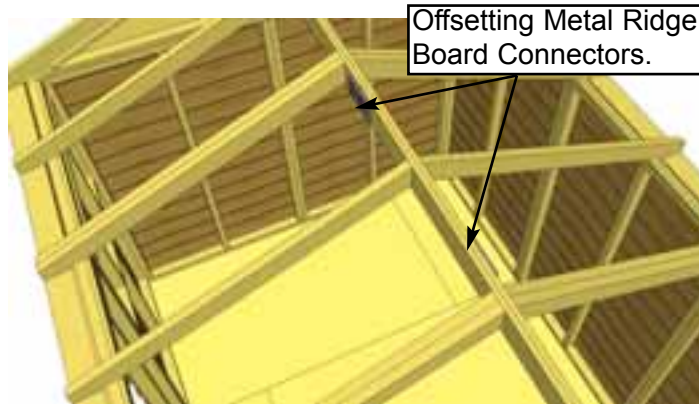
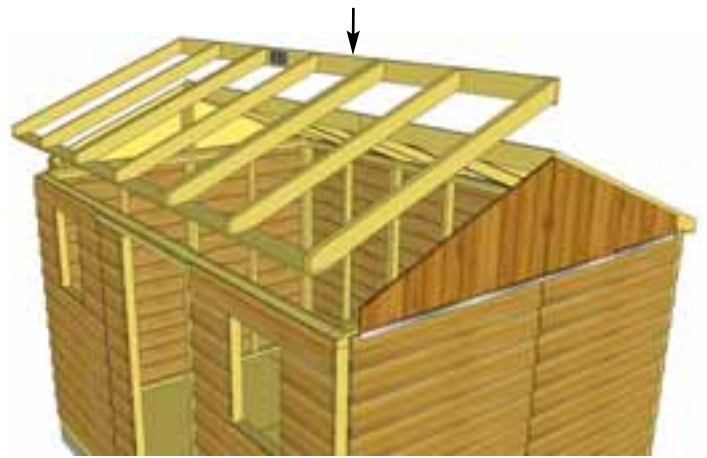
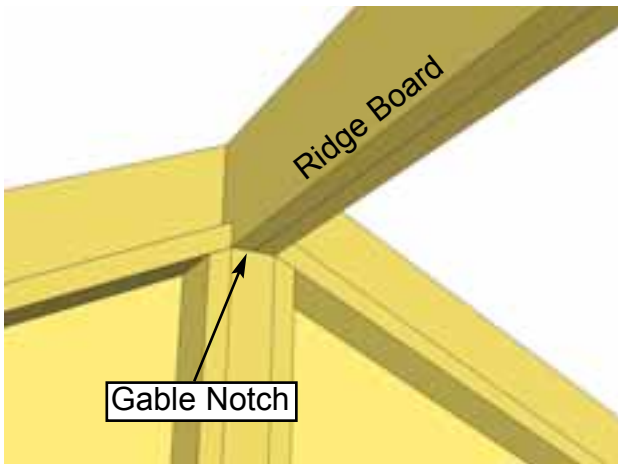

C8. Place front completed Rafter Section on gable walls as per Steps C5 - C7.

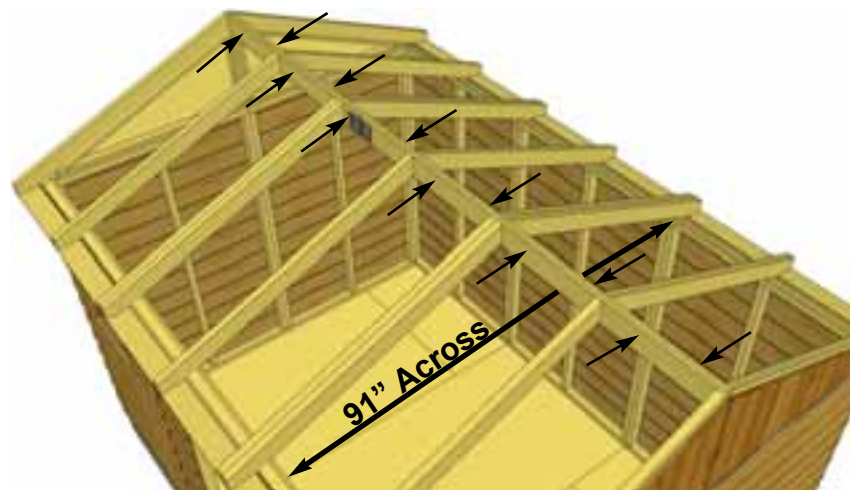
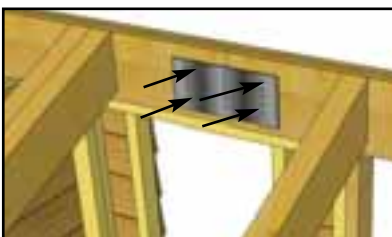

C9. At the peak, align Ridge Boards so they are flush together and secure them with 12 - 1 1/4" Screws.

Important: If there is a gap between Ridge Boards, have a helper push the front and rear walls closer together from outside. Walls should be 91" apart at top from inside of wall plate to opposite wall plate. To completely secure Ridge Boards, place 1 1/4" Screws into any of the remaining metal Ridge Board Connector holes. Complete both sides.

Hardware
1 1/4" Screws x 20 total (approx.)

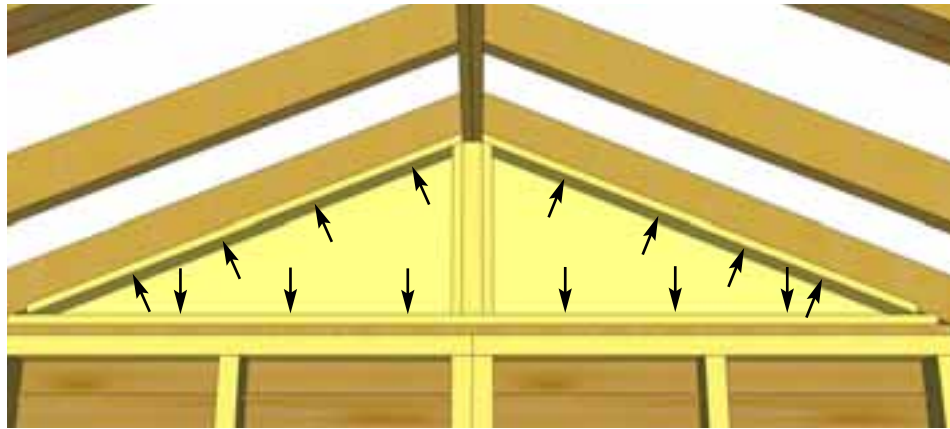

C10. With both Ridge Boards connected, completely secure Gable framing to walls and rafters. Use 4 - 2" Screws per Rafter. Use an additional 6 - 2" Screws to secure Gable to wall. **Note:** you may have to remove the 2 temporary screws in Gable from Step B15 and reposition Gable for best fit prior to completing Gable attachment.

<p><u>Hardware</u> 2" Screws x 28 total</p>

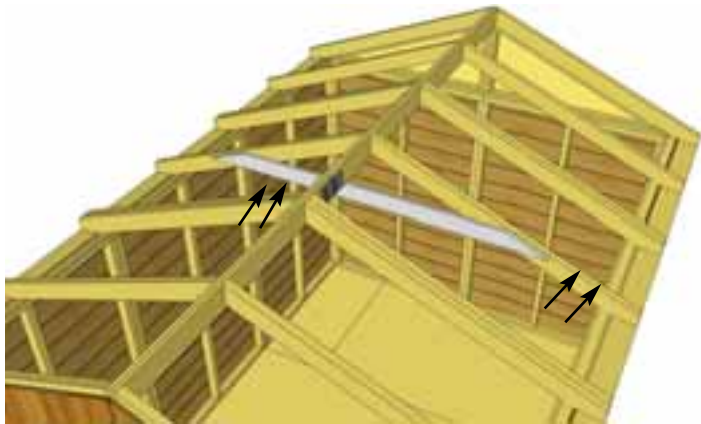
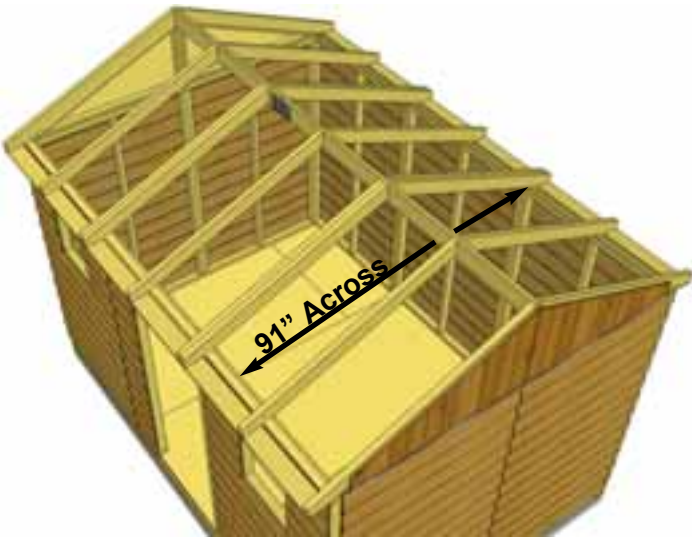

C11. Roof Gussets are positioned on mid rafters. Have two helpers push the Front and Rear Walls at the top from the outside of shed until inside to inside measurement between the Top Plates is 91". Slide Gusset up on side of Rafters. Gusset must be below top edge of Rafter. Use level to square Gusset and attach to Rafters with 4 - 2" Screws. Pilot hole each Gusset end with 1/8" drill bit.

<p><u>Parts (Steps C11 - C12)</u> Roof Gussets (3/4" x 3 1/2" x 72") x 3</p>	<p><u>Hardware (Steps C11 - C12)</u> 2" Screws x 12 total</p>
---	--

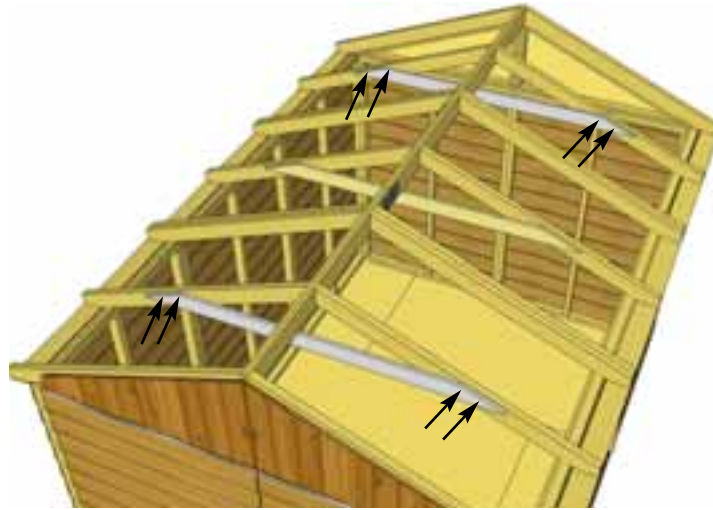

C12. Complete remaining 2 Gussets as per Step C11.

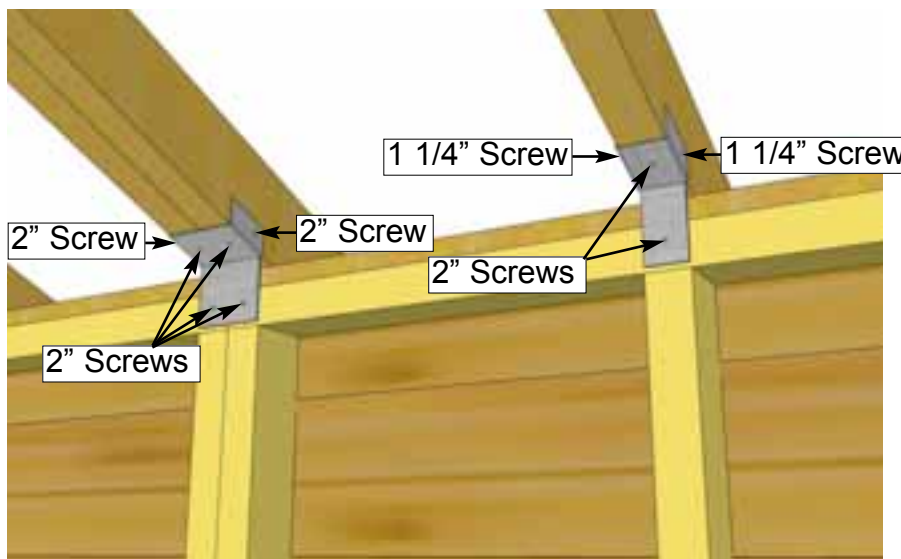

C13. Attach all Single and Double Rafter Brackets where rafters meet Top Wall Plates inside of shed. Attach with 2 - 1 1/4" Screws and 2 - 2" Screws per **Single Rafter Bracket** and 6 - 2" Screws per **Double Rafter Bracket**. Have two helpers hold the Front and Rear Walls at the top from the outside of shed to keep the inside-to-inside measurement between the Top Plates at 91".

Hardware

- Single Rafter Brackets x 6 total
- Double Rafter Brackets x 4 total
- 1 1/4" Screws x 12 total
- 2" Screws x 36 total

D. Roof Section - Cedar

**Exploded view of all parts necessary to complete the Roof Section.
Identify all parts prior to starting.**

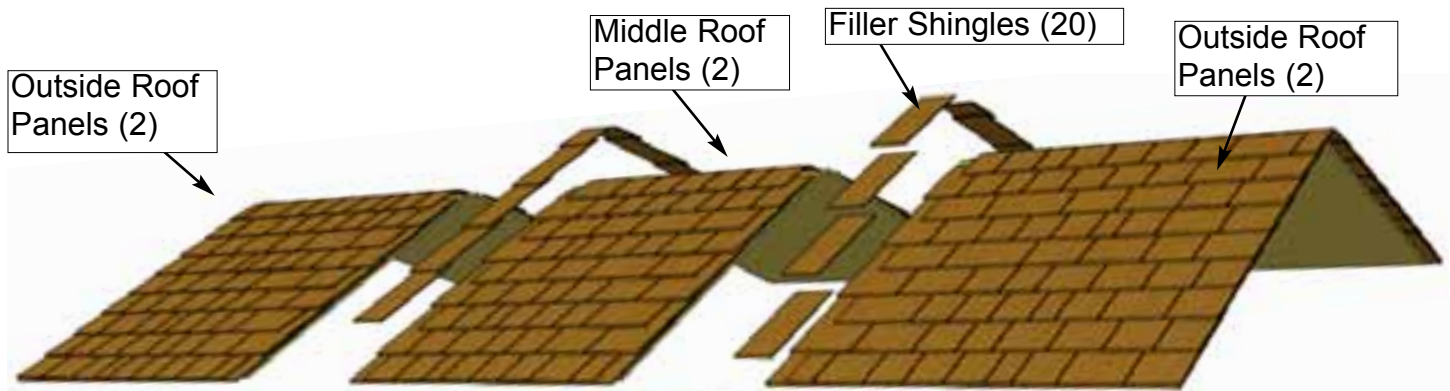

Exploded view of upside down roof panels.

Shingles overhang plywood on outside panels.

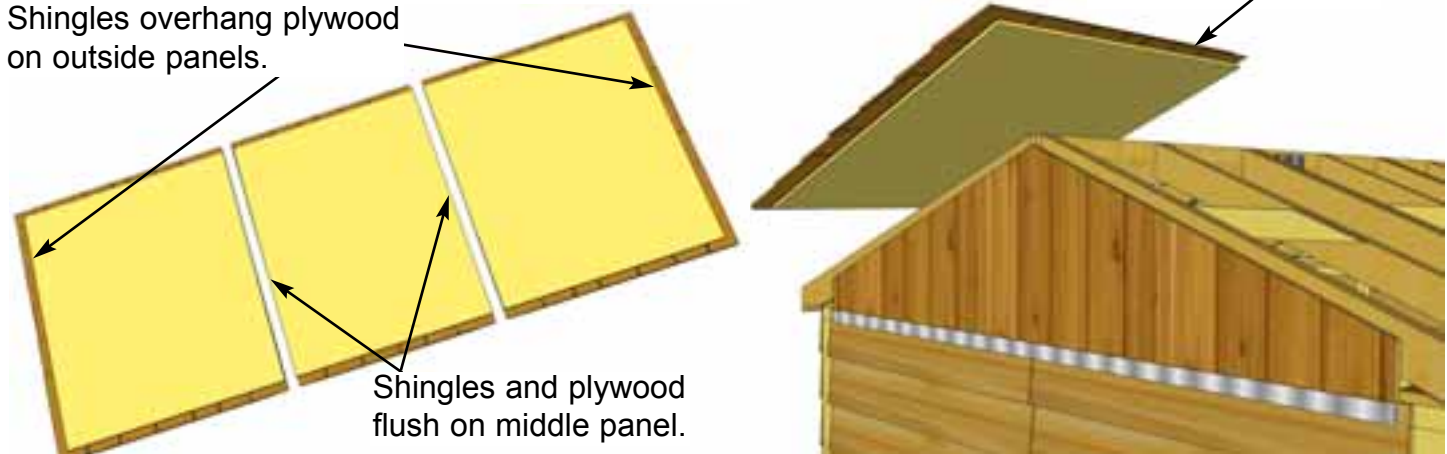

D1. Identify all Roof Panels. There are 4 Outside and 2 Middle Roof Panels. Outside Panels will have shingles overhanging the plywood on one side. Lift up and place an Outside Roof Panel on Rear Rafters.

<p><u>Parts (Steps D1 - D5)</u> Outside Roof Panels (51" wide) x 4 Middle Roof Panels (45 1/2" wide) x 2</p>	<p><u>Hardware (Steps D1 - D5)</u> 2 1/2" Screws x 8 total</p>
--	---

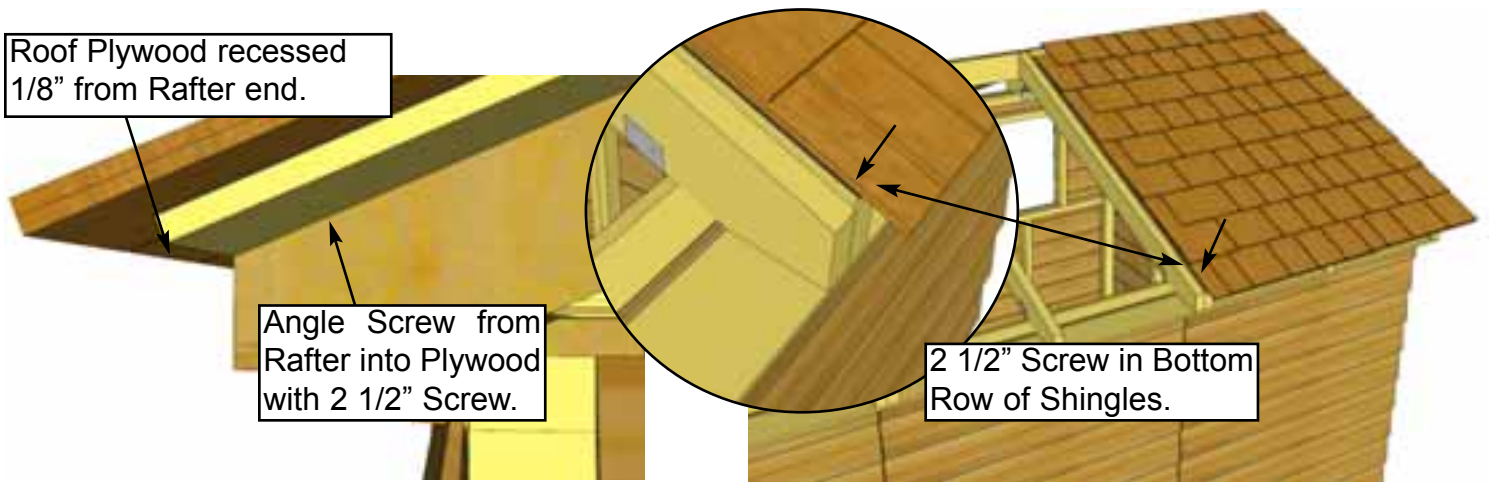

D2. Place **Outside Roof Panel** so it sits flush on 3rd Rafter from the outside (doubled up Rafter). Plywood on roof should be flush with end of Rafter at bottom, and with seam of doubled up Rafters. From the outside, screw down through bottom row of shingles into Rafter with 1 - 2 1/2" Screw. Angle 1 - 2 1/2" Screw from outside Rafter into roof plywood.

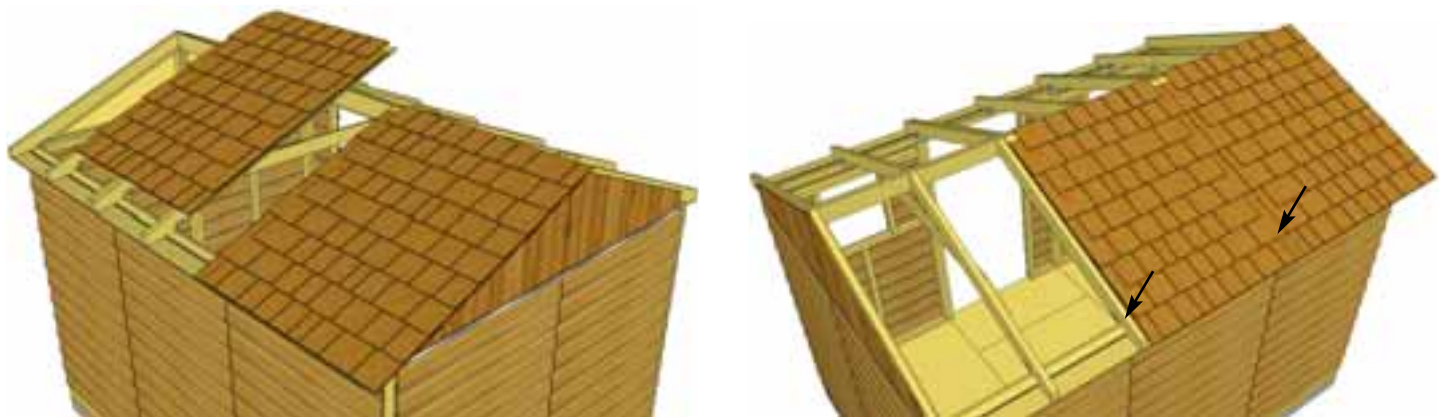

D3. Locate a **Middle Roof Panel** (roof plywood flush with outside of shingles), and place on middle Rafters. Align panel as per **Step D2** and screw panel down to Rafters with 2 - 2 1/2" Screws in the bottom row of shingles.



D4. Lift up, position and attach 2nd **Outside Roof Panel** on Rafters as per **Step D2**.

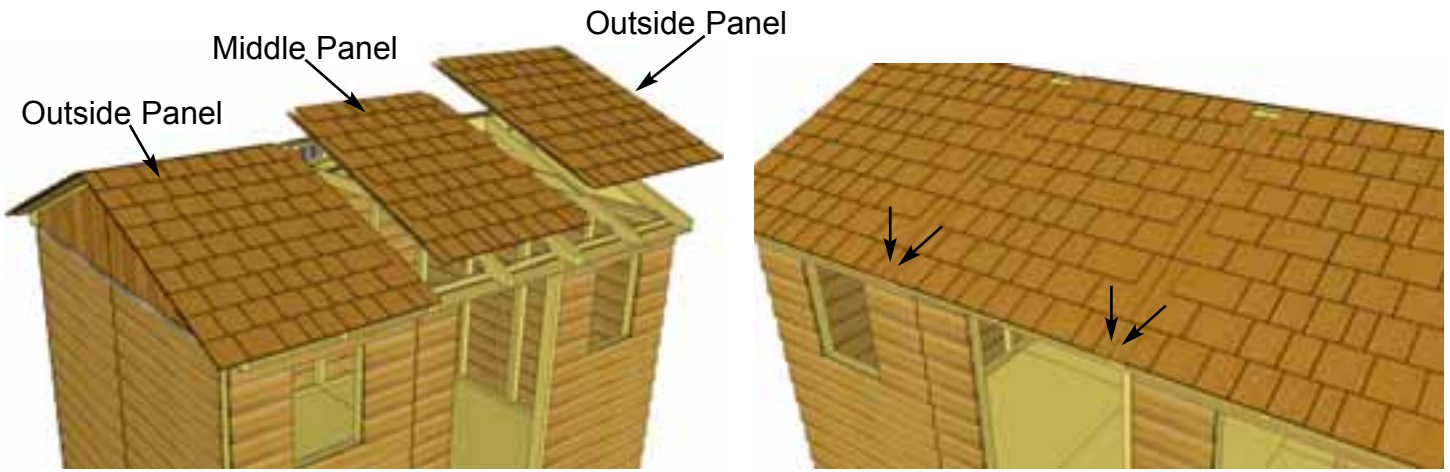

D5. Position and attach Front Roof Panels as per Steps D1 - D4.



D6. Roof Filler Shingles are included to cover roof seams. Starting at the bottom, slide the first Long Shingle in until flush with other bottom shingles.

<p><u>Parts (Steps D6 - D8)</u> Filler Shingles - Long x 16 Filler Shingles - Short x 4</p>	<p><u>Hardware (Steps D6 - D8)</u> 2 1/2" Screws x 32 total 1 1/2" Shingle Nails x 8 total</p>
---	--

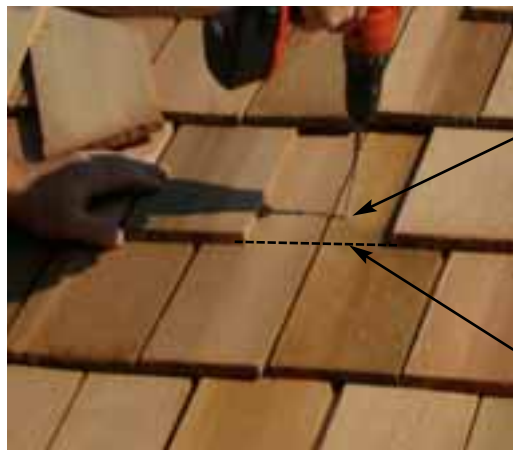

Attach above the exposure line.
 Exposure Line

D7. Screw first filler shingle down to rafters using 1 - 2 1/2" Screw per panel (2 in total). Make sure to screw into both rafters.

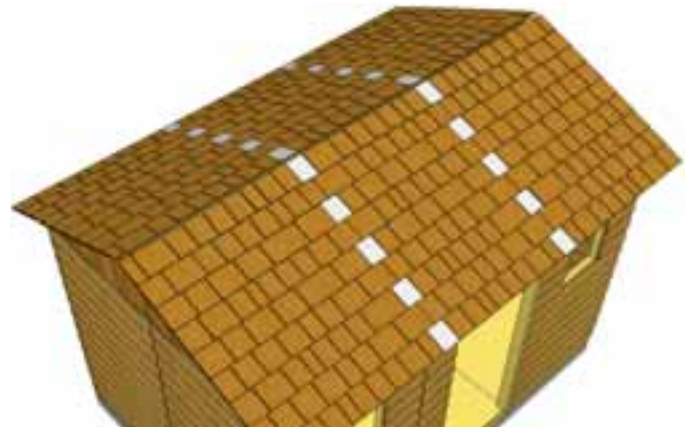

D8. Slide in another filler shingle and attach as per **Step D7**. On your last row of shingles, attach smaller filler shingle with 2 - 1 1/2" Shingle Nails near the top, to be covered by Ridge Caps in **Step D11**. Complete all four rows of filler shingles where roof seams meet in the same way.

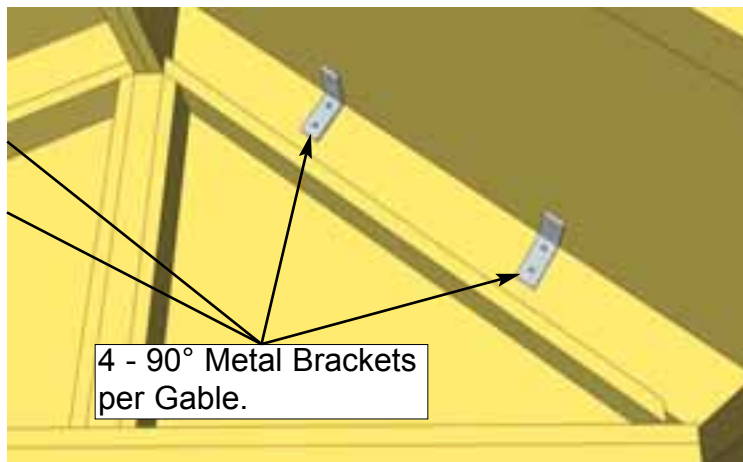

4 - 90° Metal Brackets per Gable.

D9. Inside the shed, position 2 - 90° Metal Brackets onto the roof plywood and outside rafter and secure with 4 - 1 1/4" Screws each. Complete for both Gables - there are 4 Brackets per Gable.

Hardware
 90° Metal Bracket x 8 total
 1 1/4" Screws x 32 total

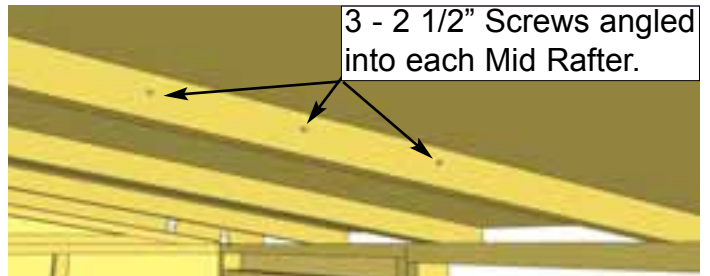
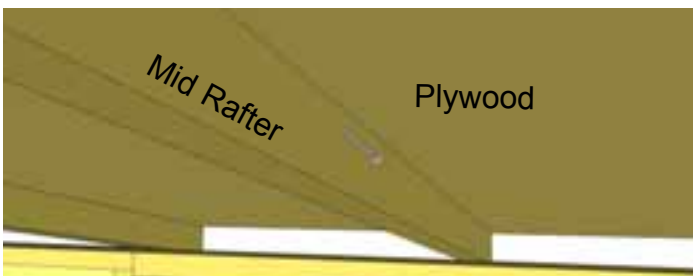

D10. To further secure roof panels, from the inside, drill pilot holes in each Mid Rafter (3 per Rafter) on an angle. Using 3 - 2 1/2" Screws, secure rafters to roof plywood. **Note:** from outside, have a helper push roof panel down so plywood sits flush against rafter when securing.

Hardware
 2 1/2" Screws x 18 total

Alternate Ridge Cap seams
(Offsetting angle cut at peak)

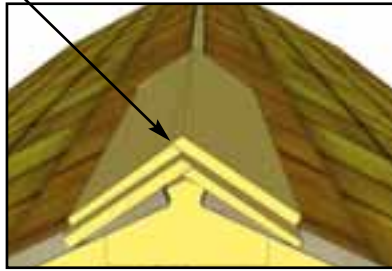
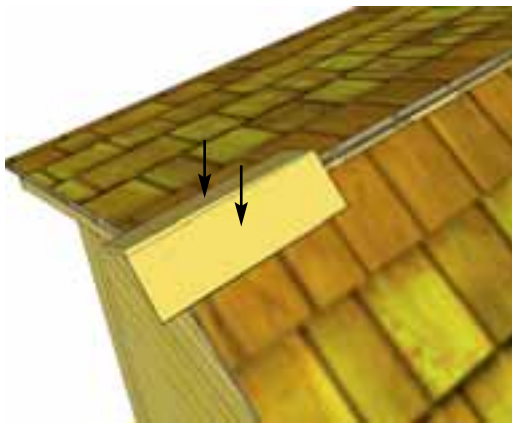

Important: Butt (thick) end of Ridge Cap will be facing towards the outside of shed.

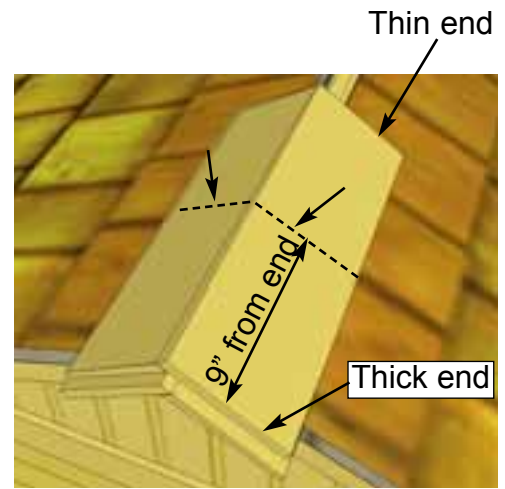

D11. Place 1st **Roof Ridge Cap** on roof peak overhanging shingles by approximately 1". Attach with 2 - 1 1/2" **Shingle Nails** 9" from end. Place 2nd Ridge Cap 1" back from 1st cap. Attach with 2 - 1 1/2" **Shingle Nails** 9" from end. Alternate each Ridge Cap seam as you proceed.

Parts (Steps D11- D12)
Roof Ridge Caps x 22

Hardware (Steps D11 - D12)
1 1/2" Shingle Nails
x 46 total

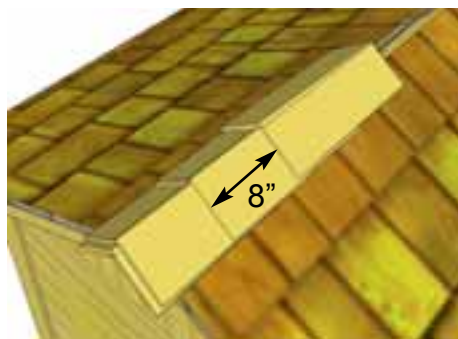
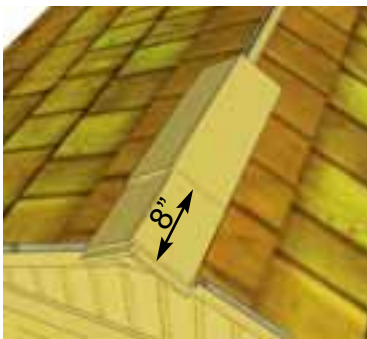

D12. Place 3rd Ridge Cap 8" back from 2nd (enough to cover shingle nails). Attach 3rd Ridge Cap as per **Step D11**. Continue to position and attach Ridge Caps until half the roof is complete. From opposite side, position and attach Ridge Caps as described above. One Ridge Cap is cut shorter to fit in the center of the roof. Attach center cap with 4 - 1 1/2" **Shingle Nails**.

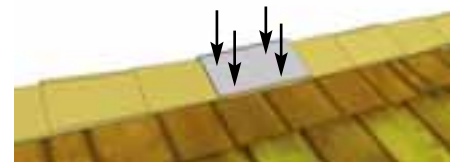

D. Roof Section - Metal

Exploded view of all parts necessary to complete the Roof Section. Identify all parts prior to starting.

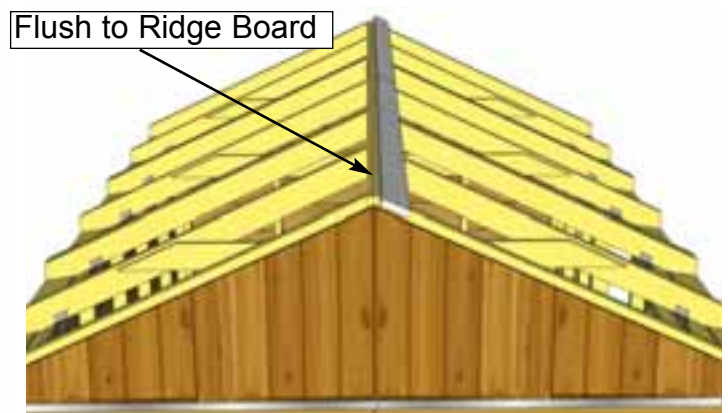
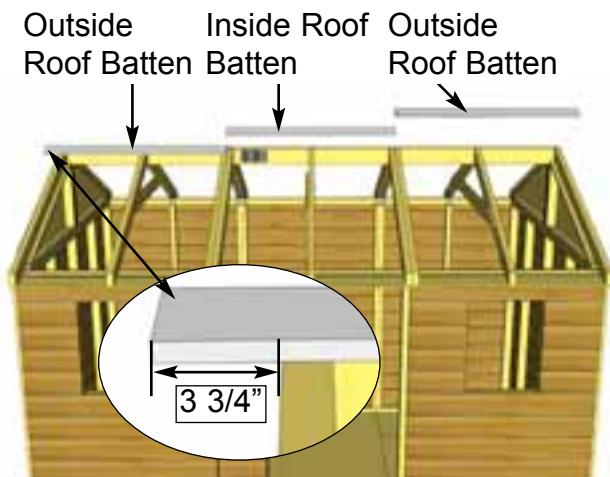
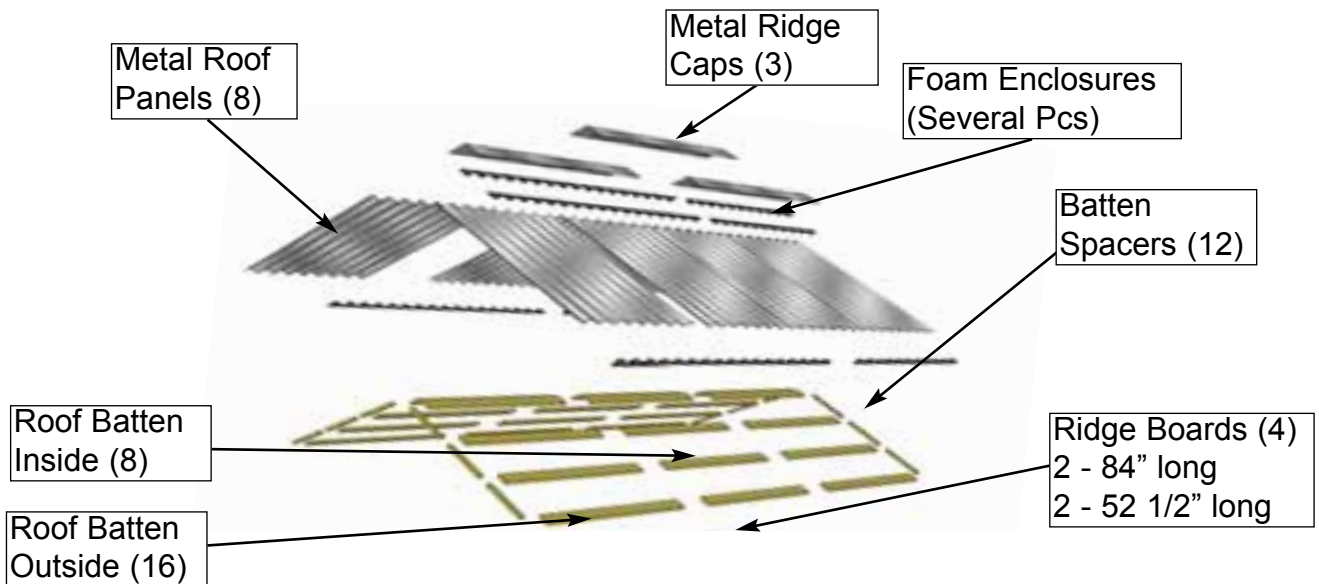

D1. Locate 2 **Outside Roof Battens** and 1 **Inside Roof Batten**, place on Roof Rafters. Place at top of Rafter section where Rafters and Ridge boards meet. Battens should be positioned evenly on 3rd and 6th Rafters. Battens will overhang outside Rafter by 3 3/4".

Hardware (Steps D1 - D7)

1 1/4" Screws
92 x total

Parts (Step D1 - D7)
Roof Battens Outside
(3/4" x 3 1/2" x 49 1/4") x 16
Roof Battens Inside
(3/4" x 3 1/2" x 45 1/2") x 8
Batten Spacer
(3/4" x 1 1/2" x 14 1/8") x 12

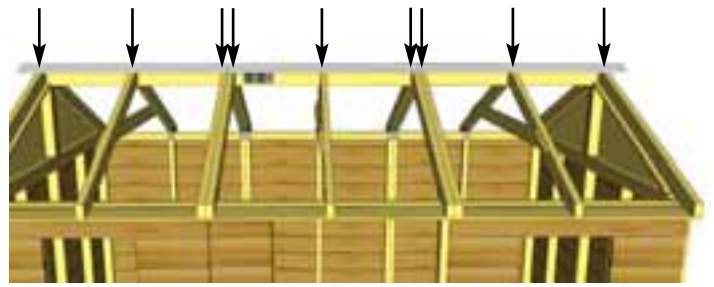
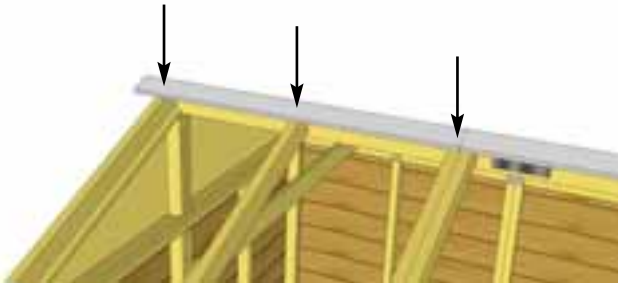

D2. Attach each **Batten** to Rafters with **3 - 1 1/4" Screws** per Batten. **Important:** pre-drill pilot holes with 1/8" drill bit first to prevent splitting.

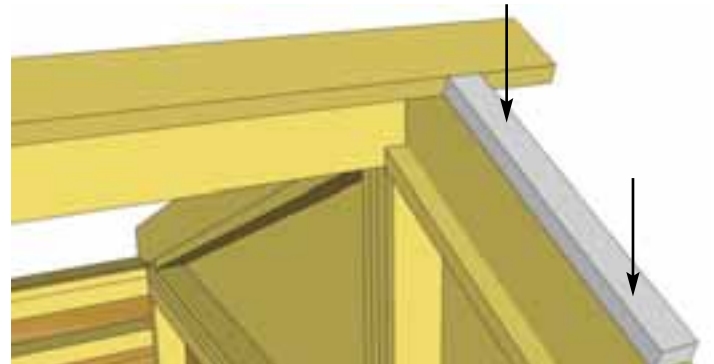
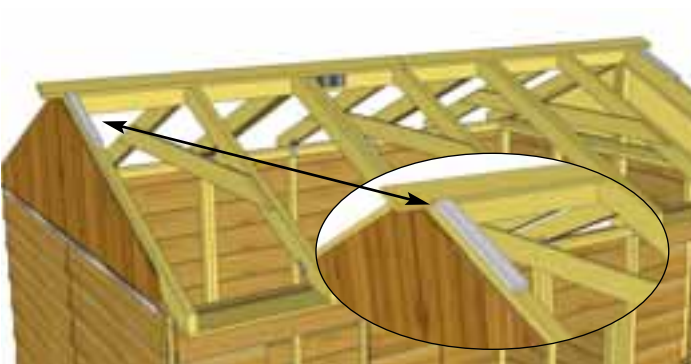

D3. Place **Batten Spacer** flush with first set of Battens on outside Rafter. Batten Spacer allows you to line up next row of Battens. Attach each with **Batten Spacer** with **2 - 1 1/4" Screws**.

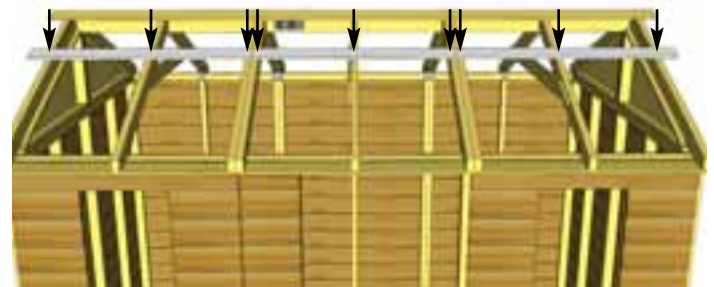
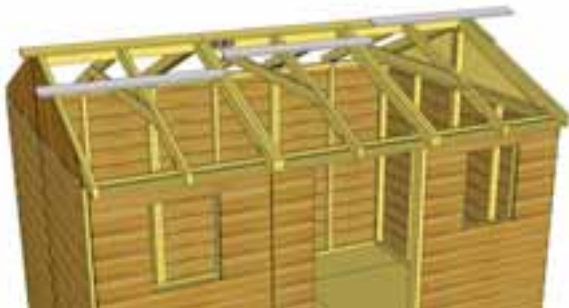

D4. Locate **2 Outside Roof Battens** and **1 Inside Roof Batten**. Place outside Battens flush with Batten Spacers and overhanging outside Rafter by 3 3/4". Secure row of Battens to Rafters with **9 - 1 1/4" Screws** (3 screws per Batten).

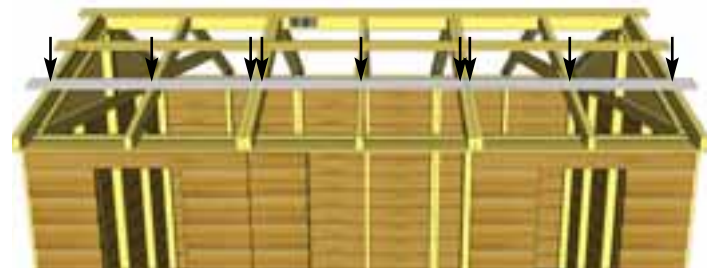
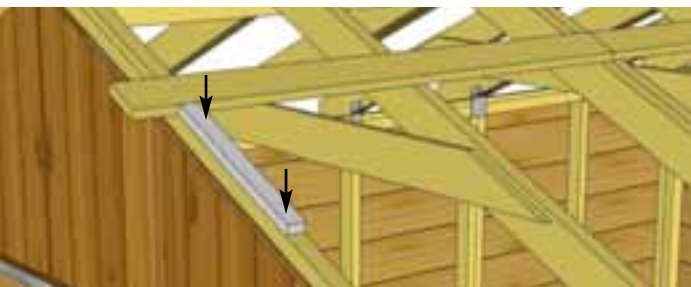

D5. Locate another pair of **Batten Spacers** and position flush with second row of Battens. Attach Batten Spacers to outside Rafter with **2 - 1 1/4" Screws** per **Spacer**. Locate **2 more Outside Roof Battens** and **1 Inside Roof Batten**, position Battens flush to **Batten Spacers**. Attach each **Batten** to Rafters with **3 - 1 1/4" Screws** (9 total).

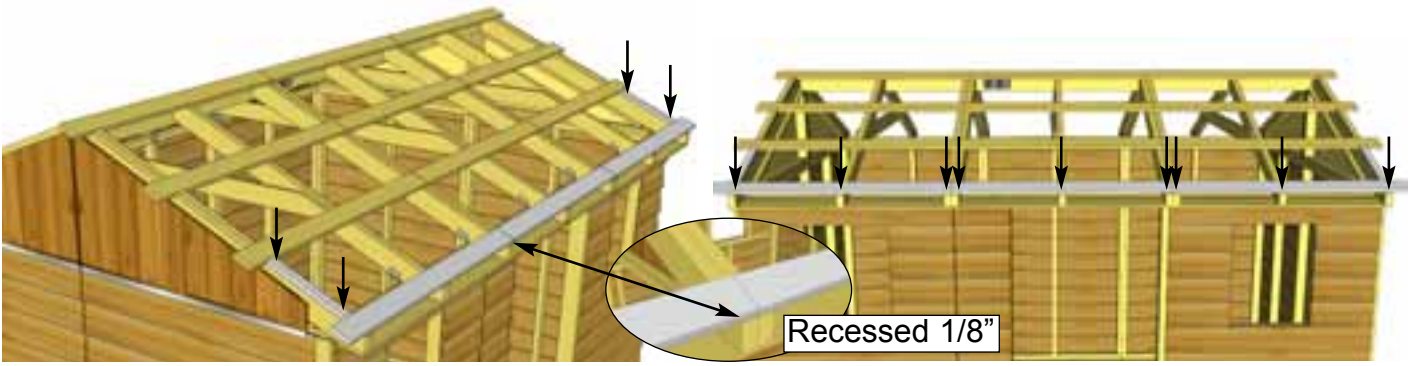

D6. Locate another pair of **Batten Spacers** and position flush with third row of Battens. Attach Batten Spacers to outside Rafter with 2 - 1 1/4" Screws per **Spacer**. Locate 2 more **Outside Roof Battens** and 1 more **Inside Roof Batten**. Position Battens flush to **Batten Spacers**, **Battens** should be recessed 1/8" from end of Rafters. Attach each **Battens** to Rafters with 3 - 1 1/4" Screws (9 total).



D7. Repeat Steps D1 - D6 to complete Batten Section on opposite side of roof with remaining **Battens** and **Batten Spacers**.

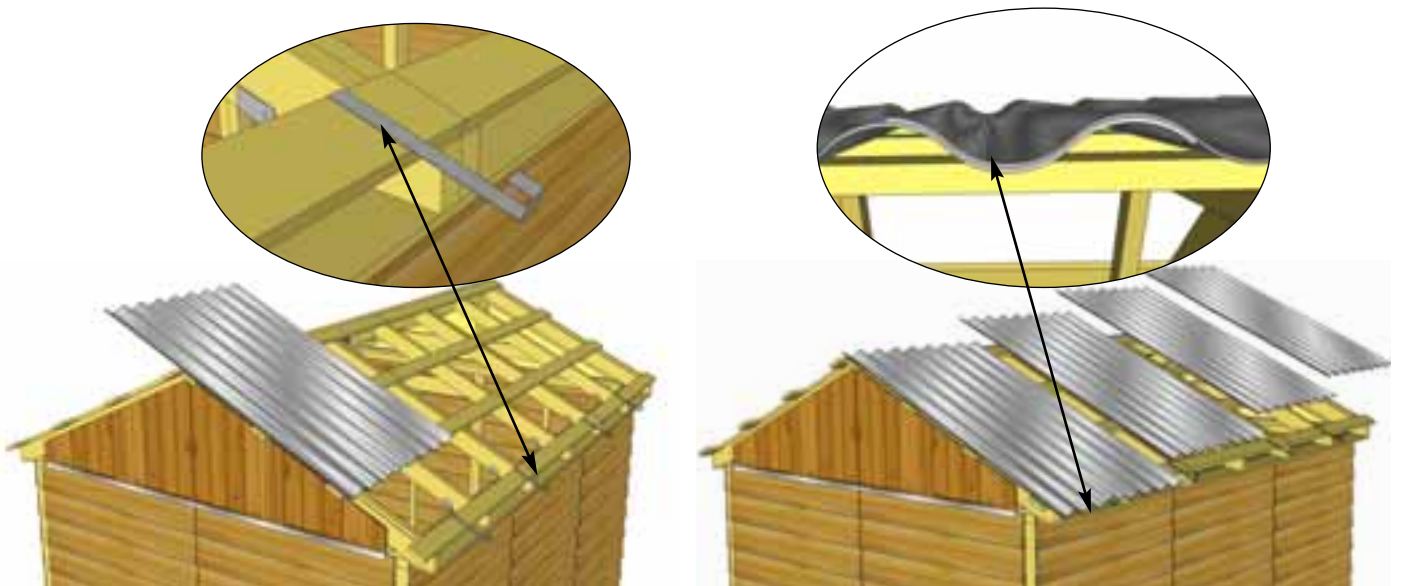

D8. Locate 4 **Metal Roof Panels** and 4 **Metal Roof Hangers**. To temporarily hold the **Metal Roof Panels** in place, hook a **Metal Roof Hanger** onto the lowest Batten, approximately where the center of the panels will be. Place first **Metal Roof Panel** on Battens and into Hanger. Do not fasten panels down until **Step D13**. Place remaining 3 panels and hangers on the same way. Metal Roof Panels will overlap each other.

<p><u>Parts (Step D8)</u> Metal Roof Panels (39" wide x 61" long) x 4</p>
<p><u>Hardware (Step D8)</u> Metal Roof Hangers x 4</p>



D9. Overhang the **Metal Roof Panels** past the **Battens** on front and rear of shed by approximately 1". Adjust panels side-to-side to achieve desired width. Overall width past the **Battens** can vary from 1" - 3" depending on your preference. The overhang over the side of the shed will be set by the **Metal Roof Hangers**, but should be approximately 4" on side of shed.

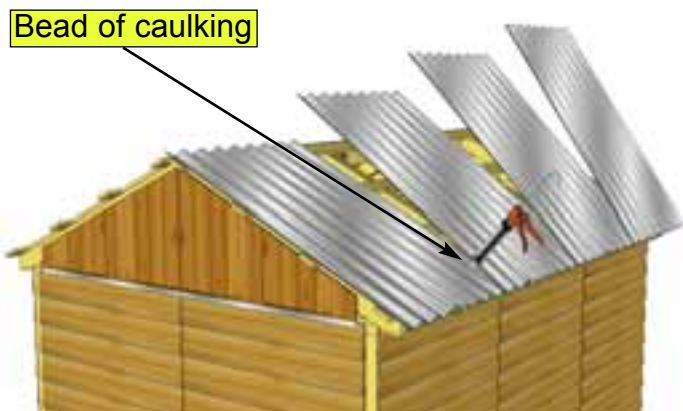

D10. Once the Metal Roof Panels are spaced correctly from side-to-side and top-to-bottom, lift 3 panels up and run a bead of caulking down the overlapping seams of each panel to seal the joints. Place panels down one by one once seam is caulked. You will likely need assistance from a helper for this step. Caulk each seam.

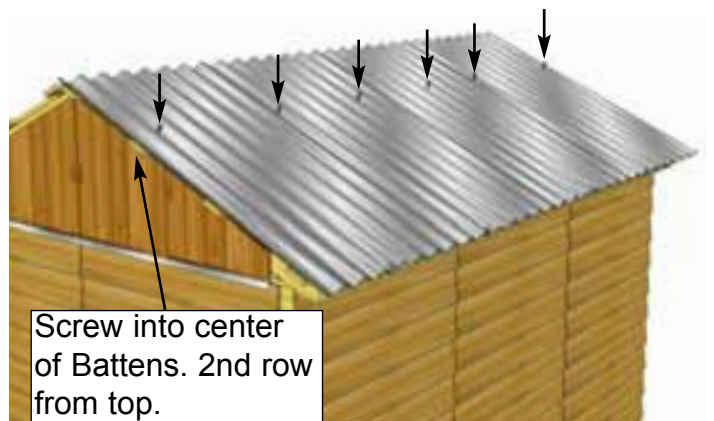
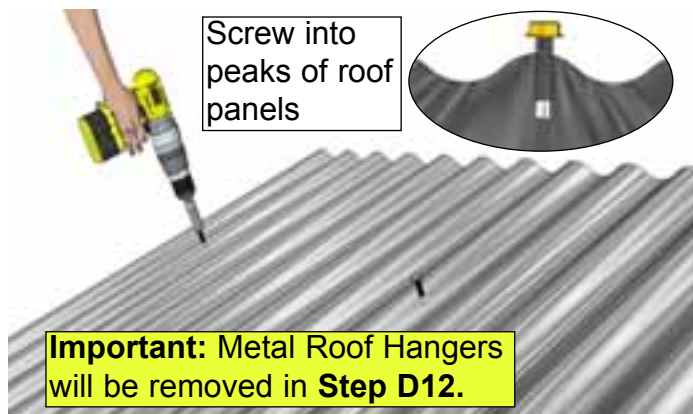

D11. Using 6 - 1 1/2" Metal Screws and 1/4" Nut Driver (included), partially secure **Metal Roof Panels** to 2nd row of **Battens** from top. Only fasten screws halfway so that **Metal Roof Hangers** can be removed in **Step D12**. Metal screw is self-tapping, screw into center of Battens

Hardware (Step D11)
 1 1/2"- Metal Roof Screws
 x 6 total

Important: Remove Metal Roof Hangers

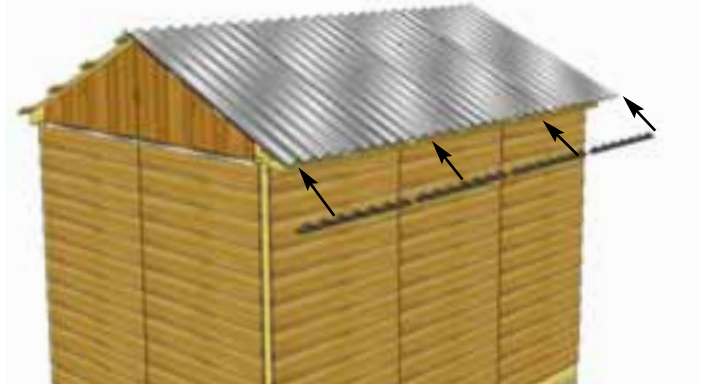
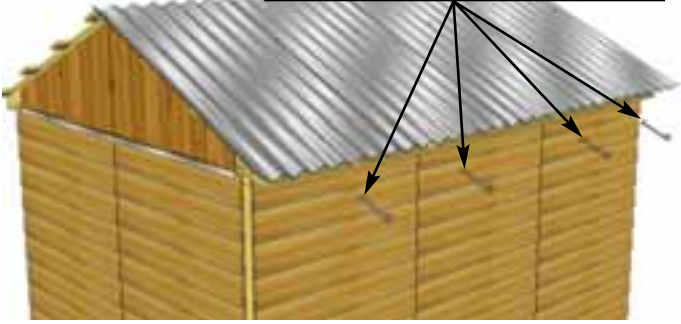

D12. Before fully fastening **Metal Roof Panels** down, remove the **Metal Roof Hangers** and insert **Foam Enclosures** between **Metal Roof Panels** and **Battens** at the bottom of the roof. Enclosures will prevent moisture and unwanted bugs, etc from entering your shed through here.

Parts (Step D12)
Foam Enclosures
 (Several Pcs)

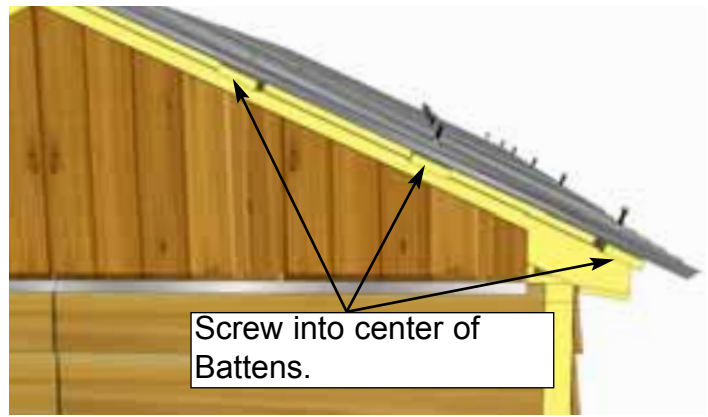
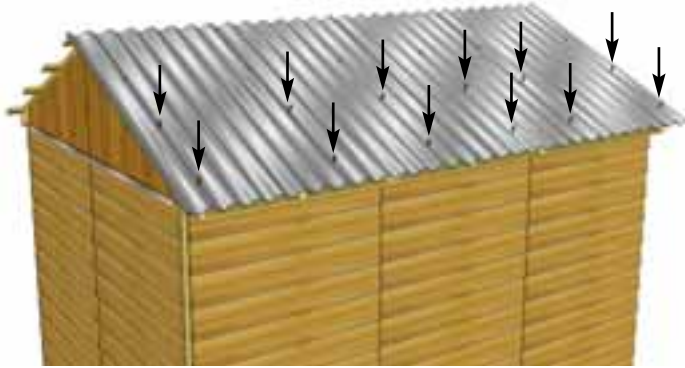

Screw into center of Battens.

D13. Using 12 - 1 1/2" **Metal Screws** and 1/4" Nut Driver, secure **Metal Roof Panels** down to lower 2 rows of **Battens**. Leave the top row unsecured for now to secure **Ridge Cap** later in **Step D16**. Tighten screws in middle row that were partially secured in **Step D16**. Do not overtighten!

Hardware (Step D13)
1 1/2"- Metal Roof Screws
 x 12 total



D14. Repeat **Steps D8 - D13** to complete opposite side of **Metal Roof**.

Hardware (Step D14)
1 1/2"- Metal Roof Screws
 x 18 total



D15. Locate remaining **Foam Enclosures**. Place **Foam Enclosures** at the top of roof panels. **Foam Enclosures** prevent moisture from coming in through the top of your shed.

Parts (Step D15)
Foam Enclosures
 (Several Pcs)



D16. Place 3 **Metal Ridge Caps** onto apex of roof. Evenly space from front to back of your shed, Metal Ridge Caps will overlap each other. Overhang the cap approximately 1" - 2" past each end. When **Metal Ridge Caps** are correctly positioned, secure with 12 - 1 1/2" **Metal Ridge Screws** (6 per side). Screw into center of final **Batten**. Do not overtighten!

Parts (Step D16)
Metal Ridge Caps
 (60" long) x 3

Hardware (Step D16)
 1 1/2" - **Metal Ridge Screws**
 x 12 total

D. Roof Section - Plywood

Exploded view of all parts necessary to complete the Roof Section. Identify all parts prior to starting.

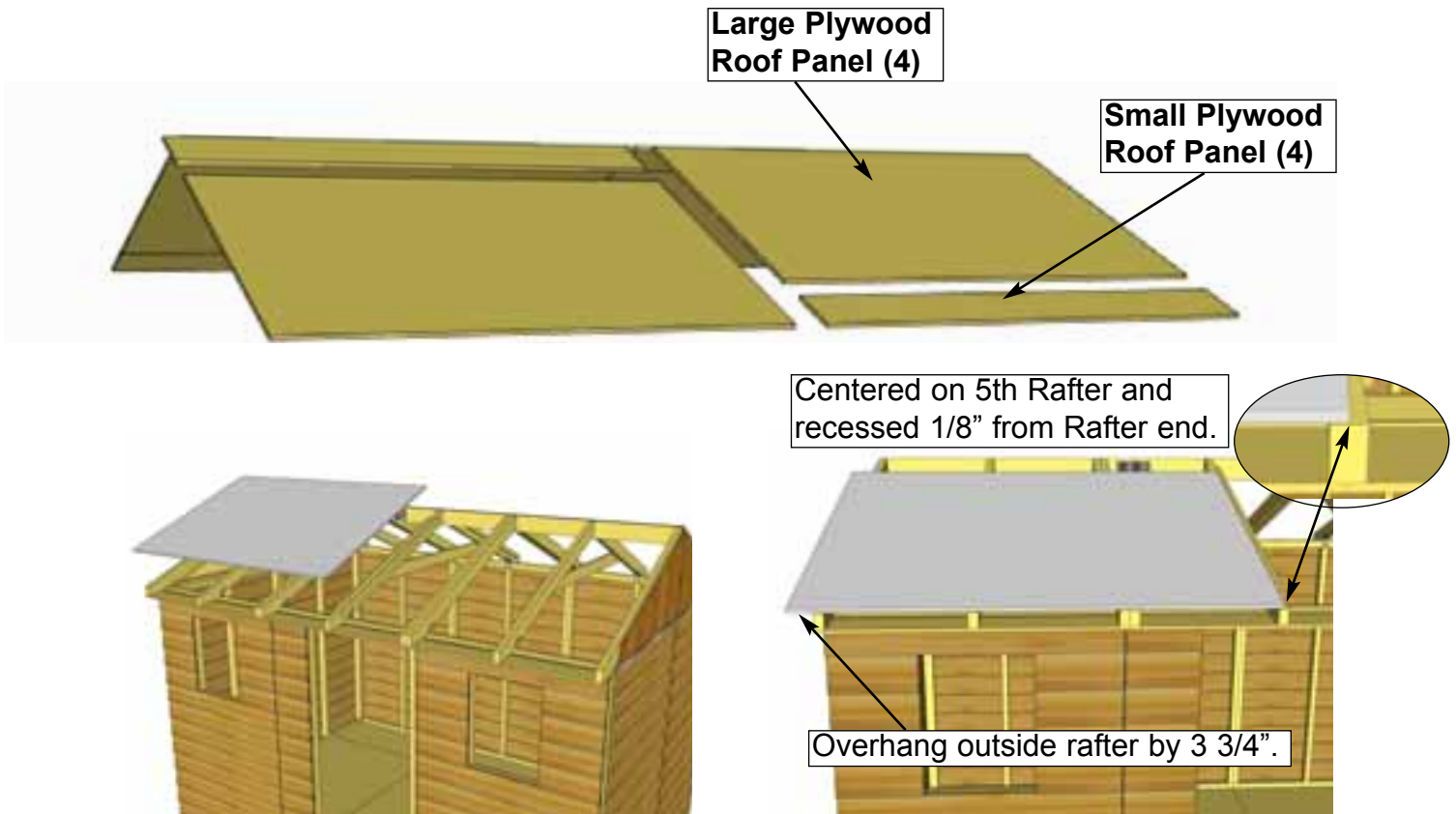

D1. Locate one sheet of **Roof Plywood Large**. Position on right side of shed. Recess plywood back approximately 1/8" from end of Rafter. Plywood will overhang outside Rafter by 3 3/4" and on opposite side, plywood will be centered on 5th rafter, being supported by **Rafter Nailing Cleat**.

<p><u>Parts (Steps D1 - D2)</u> Roof Plywood Large (5/8" x 48" x 72") x 1</p>
<p><u>Hardware (Steps D1 - D2)</u> 1 1/4" Screws x 12 total</p>

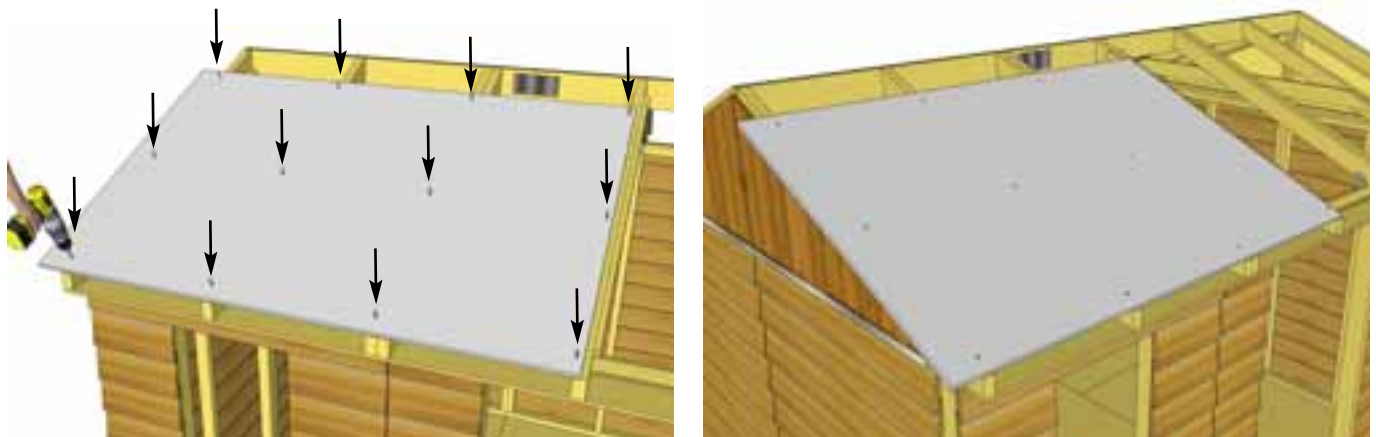

D2. With **Roof Plywood Large** correctly positioned on rafters, attach plywood to rafters with 12 - 1 1/4" screws. On 5th rafter, be sure to angle screw to hit the meat of the rafter.

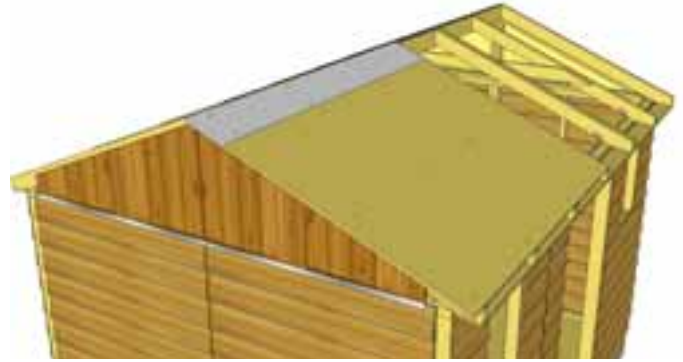
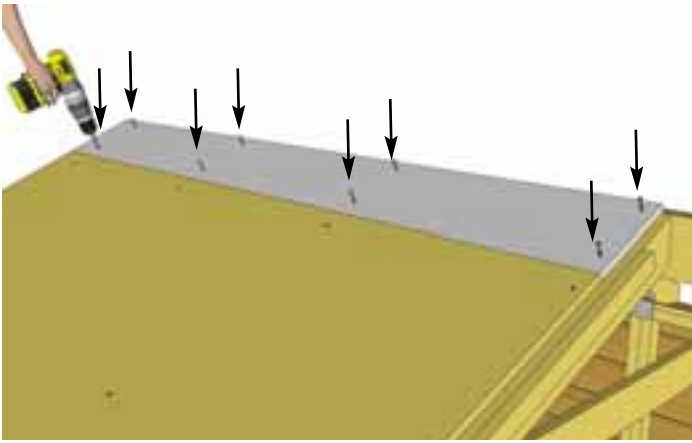

D3. Locate one sheet of **Roof Plywood Small**. Position above previous piece and attach with **8 - 1 1/4" Screws**.

Parts (Step D3)
Roof Plywood Small
 (5/8" x 8 5/8" x 72") x 1

Hardware (Step D3)
1 1/4" Screws
 x 8 total

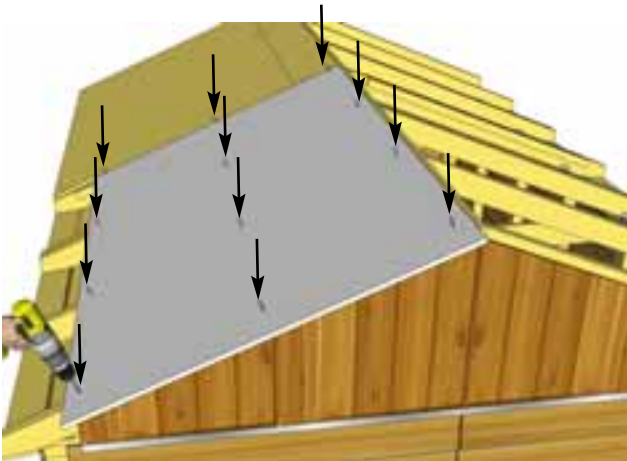

D4. Locate second sheet of **Roof Plywood Large**. Position next to first two panels near **Ridge Board** and attach with **12 - 1 1/4" Screws**.

Parts (Step D4)
Roof Plywood Large
 (5/8" x 48" x 72") x 1

Hardware (Step D4)
1 1/4" Screws
 x 12 total

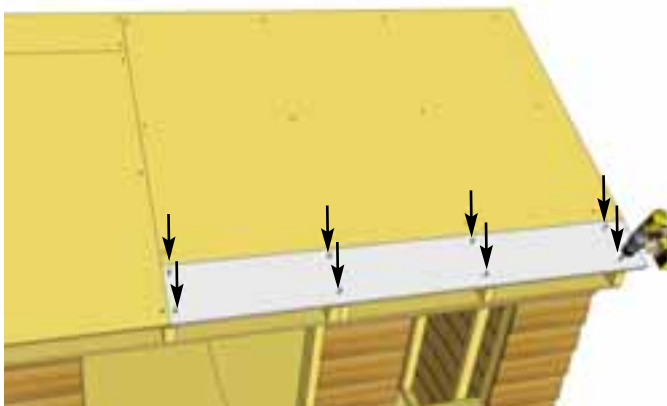

D5 Locate second sheet of **Roof Plywood Small**. Position below previous panel and attach with **8 - 1 1/4" Screws**.

Parts (Step D5)
Roof Plywood Small
 (5/8" x 8 5/8" x 72") x 1

Hardware (Step D5)
1 1/4" Screws
 x 8 total

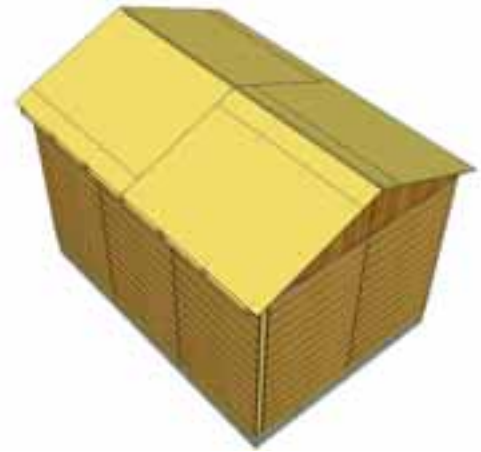

<p>D6 Repeat Steps D1 - D5 to complete opposite side of plywood roof.</p>	<p><u>Parts (Step D6)</u> Roof Plywood Small (5/8" x 8 5/8" x 72") x 2 Roof Plywood Large (5/8" x 48" x 72") x 2</p>	<p><u>Hardware (Step D6)</u> 1 1/4" Screws x 40 total</p>
--	--	--

Small gap at apex of roof

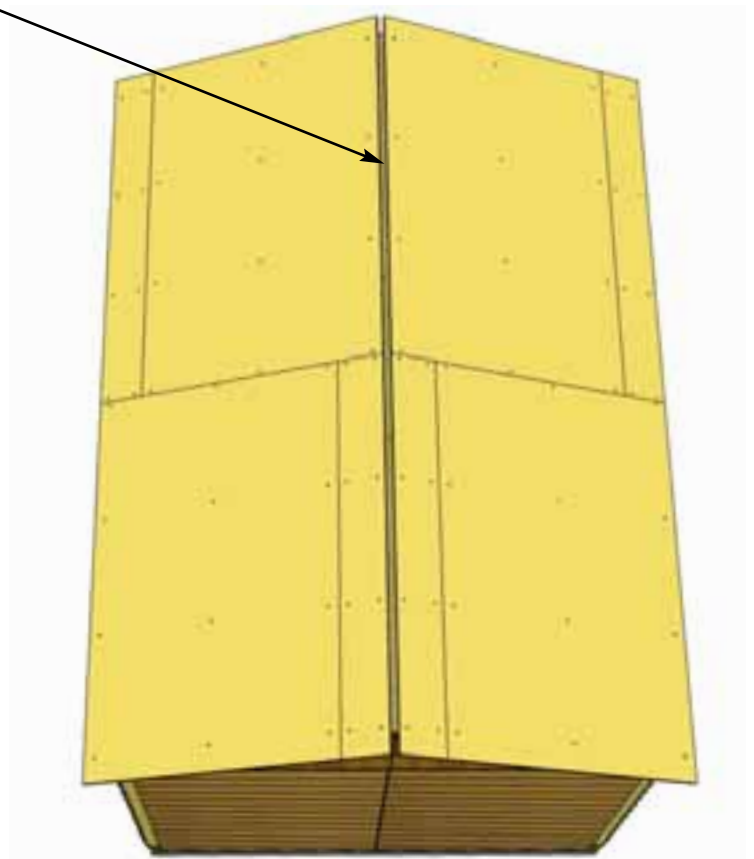

Important: Plywood roof panels must be covered with water proof roofing paper or equivalent material now. Roofing paper and roofing material is not supplied in this kit. Leaving plywood roof panels unprotected will result in water damage to the shed as well as delamination of the plywood.

E. Miscellaneous Section

Exploded view of all parts necessary to complete the Miscellaneous Section. Identify all parts prior to starting. Note: Not shown: Interior Door Stops, 1 Interior Barrel Bolt

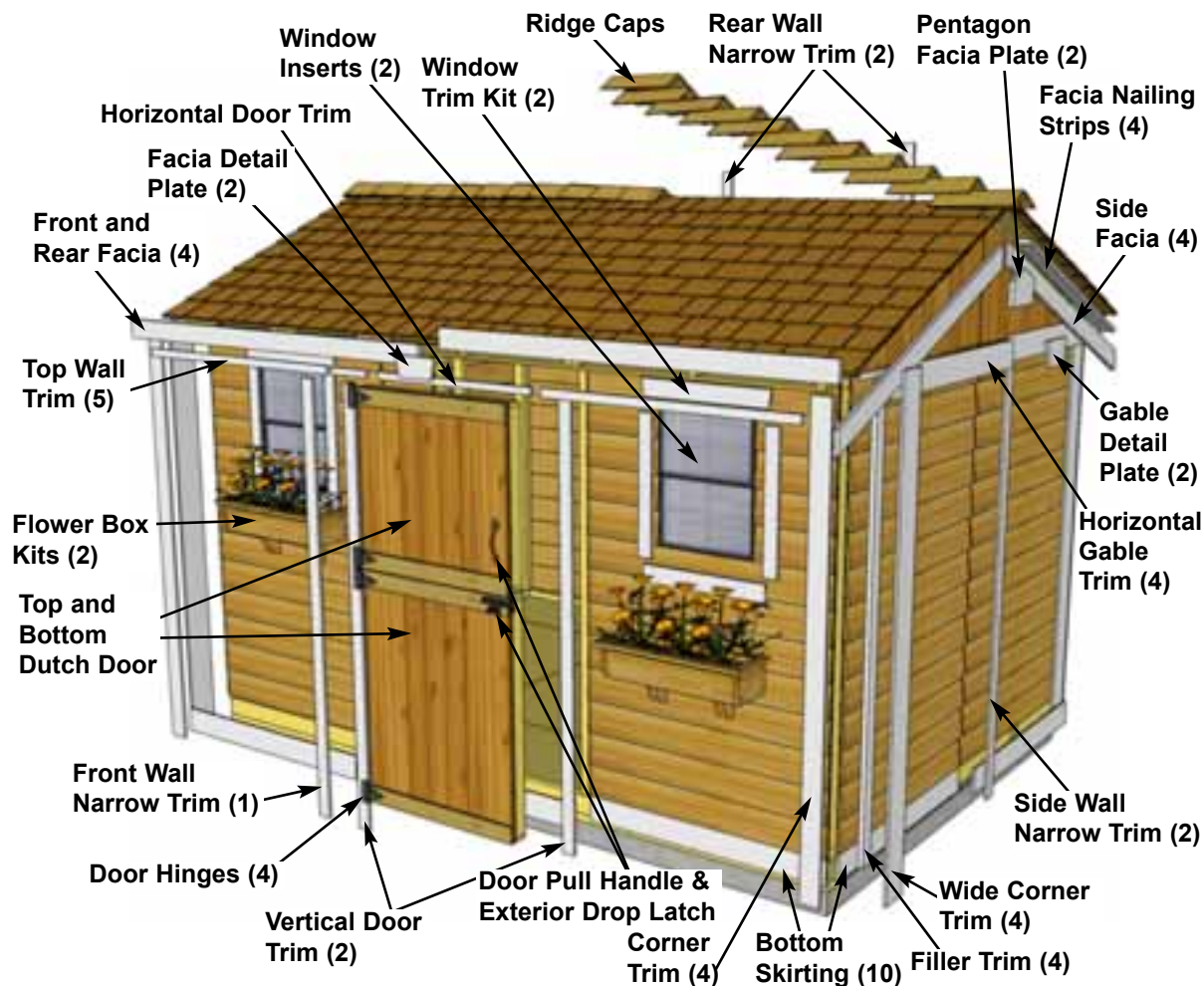

Expert Advice: When installing trim, sort pieces according to color and pieces that are most pleasing to the eye. Start with least visible side of shed and use the least desirable pieces first. Install trim to most visible side of shed as your skill installing trim improves.

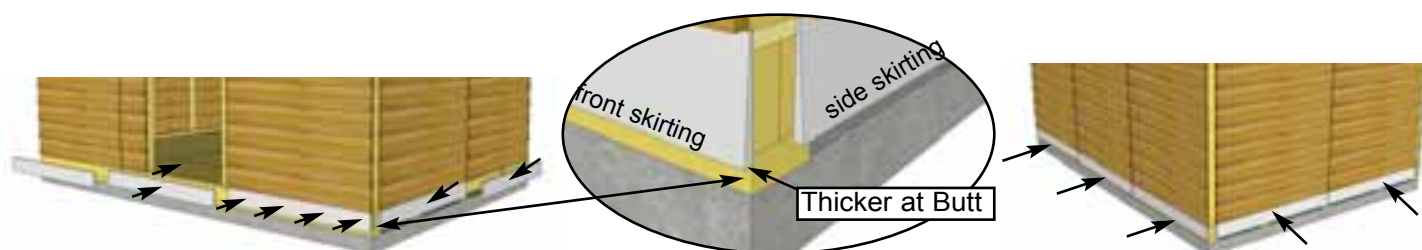

E1. Attach **Bottom Skirting - Bevel** around the base of the shed. Bevel is thicker at butt and thinner at top of board. Skirting will hide floor framing. Gaps on side will be covered by Wide Trim pieces later. Start with Front and Rear Skirting pieces first and attach with 4 - 1 1/2" Finishing Nails per piece.

Parts
Bottom Skirting - Bevel
 (3/4" x 4 1/2" x 45 1/4") x 10

Hardware
1 1/2" Finishing Nails
 x 40 total



E2. Check the wall seams for visible gaps prior to attaching filler trim and apply caulk where needed. Caulking gaps will help prevent moisture from entering and will help the longevity of your shed. **Caulking not included in kit.**

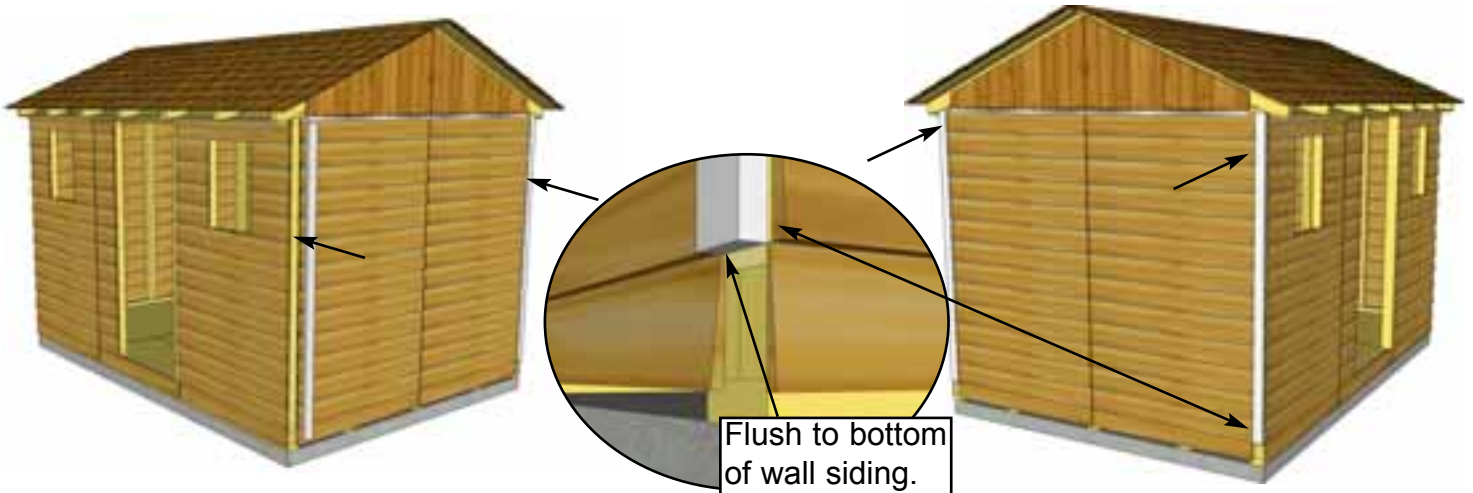

E3. Attach **Filler Trim** to each corner side wall. Align Filler Trim so it sits flush with the bottom of the last piece of Wall siding. Attach with **8 - 1 1/2" Finishing Nails** per piece.

Parts
Filler Trim
 (7/8" x 2 1/2" x 75")
 x 4

Hardware
1 1/2" Finishing Nails
 x 32 total



E4. Trim out Front Window Walls and Rear Solid Walls by attaching **Top Wall Trim**. Position with thick end of Bevel downward at top of wall, tight against Soffits. Attach with **4 - 1 1/2" Finishing Nails** per piece.

Parts
Top Wall Trim (Bevel)
 (3/4" x 1 1/2" x 45 1/4") x 5

Hardware
1 1/2" Finishing Nails x 20 total



E5. Attach **Horizontal Gable Trims** to both sides of shed (2 per side). Position over gable and wall seam with thick end of Bevel downward. Use **4 - 1 1/2" Finishing Nails** to secure each piece.

<u>Parts</u> Horizontal Gable Trims - Bevel (3/4" x 4 1/2" x 45 1/4") x 4	<u>Hardware</u> 1 1/2" Finishing Nails x 16 total
--	---

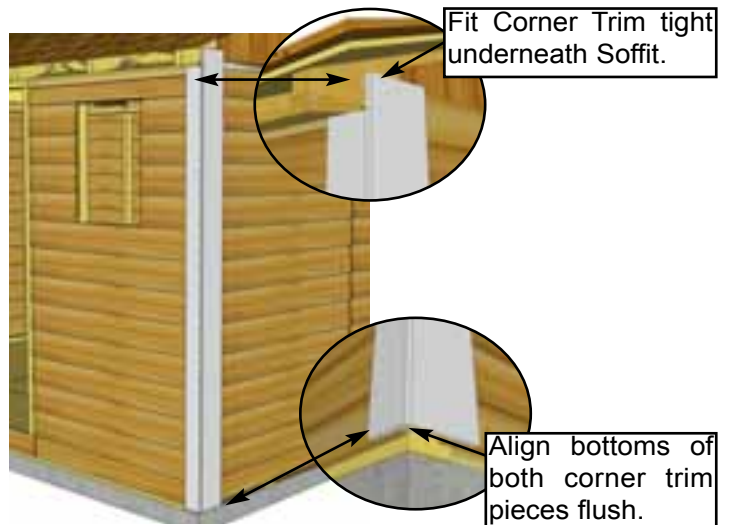
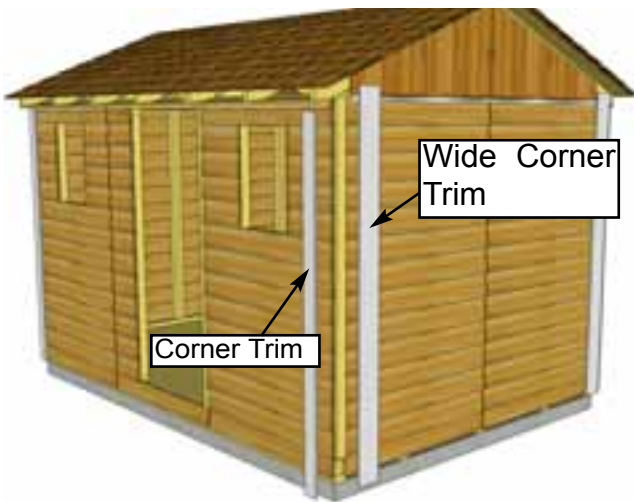

E6. To trim out corners, start with a **Corner Trim**, align tight underneath Soffit and Rafter. Align **Wide Corner Trim** with bottom of Corner Trim. Corner Trim will cap the Wide Corner Trim. Do a dry run in each corner before attaching to confirm positioning. Use **8 - 1 1/2" Finishing Nails** per piece to secure. Complete other front corner the same.

<u>Parts (Steps E6 - E7)</u> Corner Trim (1/2" x 3 1/2" x 79") x 4 Wide Corner Trim (1/2" x 5 1/2" x 82") x 4	<u>Hardware (Steps E6 - E7)</u> 1 1/2" Finishing Nails x 64 total
---	--



E7. Trim out rear corners with remaining pieces of **Corner Trim** and **Wide Corner Trim**. Align and attach with **8 - 1 1/2" Finishing Nails** per piece as per **Step E6**.

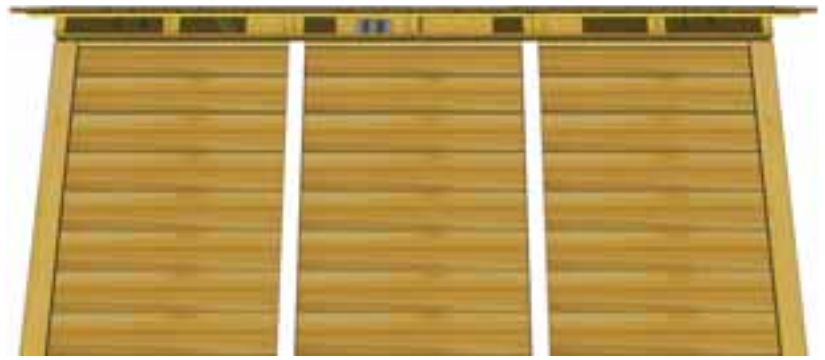

E8. Attach **Rear Wall Narrow Trim** where wall panels come together and leave a seam. Position trim equally on wall seam and tight underneath Soffit and Rafter. Use **8 - 1 1/2" Finishing Nails** per piece to secure.

<u>Parts</u> Rear Wall Narrow Trim (1/2" x 2 1/2" x 79") x 2	<u>Hardware</u> 1 1/2" Finishing Nails x 16 total
---	---

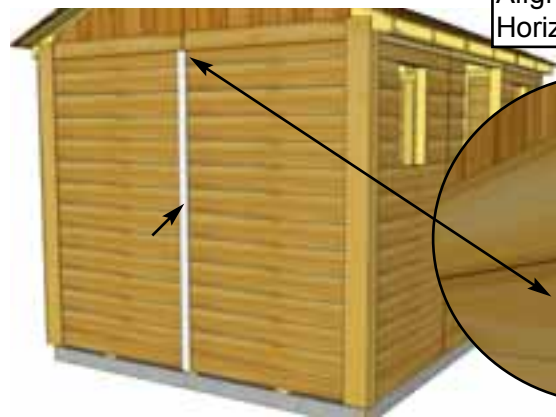

Align with bottom of Horizontal Gable Trim.

E9. Attach both **Side Wall Narrow Trims** where wall seams come together on sides. Position trim equally on wall seam and flush with the bottom of the Horizontal Gable Trim. Use **8 - 1 1/2" Finishing Nails** per piece to secure.

<u>Parts</u> Side Wall Narrow Trim (1/2" x 2 1/2" x 77 1/2") x 2	<u>Hardware</u> 1 1/2" Finishing Nails x 16 total
---	--



E10. Attach **Facia Nailing Strips** to the underside edge of the plywood roof. Align corner of Nailing Strip with edge of roof plywood. Secure each Strip with **3 - 1 1/4" Screws**. Complete all four pieces, two on each side of the shed.

<u>Parts</u> Facia Nailing Strips (3/4" x 2 1/2" x 51") x 4	<u>Hardware</u> 1 1/4" Screws x 12 total
--	---



E11. Attach **Side Fascia** to end of roof panel plywood and Nailing Strip. Line Fascia up to form a peak and attach to Nailing Strip/plywood with **6 - 1 1/2" Finishing Nails** per piece. End of Fascia should be aligned flush with end of Rafter. See **Step E12** for detail. Gap where Fascia boards come together at peak will be covered in **Step E12**.

<u>Parts</u> Side Fascia - Angle Cut Ends (3/4" x 3 1/2" x 58") x 4	<u>Hardware</u> 1 1/2" Finishing Nails x 24 total
--	--

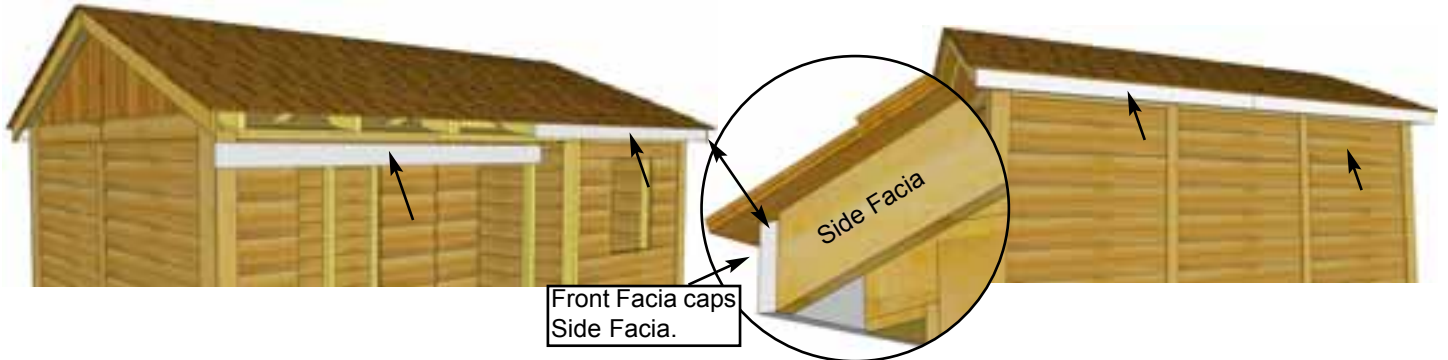

E12. Attach **Front and Rear Fascia** to rafter ends. There are 2 Fascia pieces per side. Secure with **8 - 1 1/2" Finishing Nails** per piece, ensure nails connect with the ends of the rafters behind Fascia. Gaps between Fascia pieces will be covered by Detail Plates in **Step E13**.

<u>Parts</u> Front & Rear Fascia (3/4" x 3 1/2" x 71 3/4") x 4	<u>Hardware</u> 1 1/2" Finishing Nails x 32 total
---	---

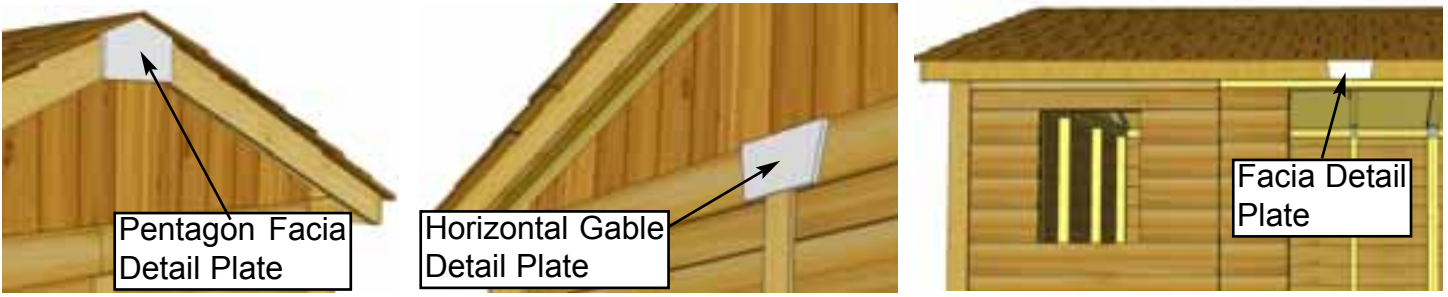

E13. Attach **Pentagon Fascia Plates** where Side Fascias meet at the peak. Secure with **4 - 1 1/2" Finishing Nails** per piece. Attach **Fascia Detail Plates** to cover seams where Front and Rear Fascia pieces meet. Secure with **4 - 1 1/2" Finishing Nails** per piece. Attach **Horizontal Gable Detail Plates** to cover seams where Horizontal Gable Trims meet. Secure with **4 - 1 1/2" Finishing Nails** per piece.

<u>Parts</u> Pentagon Fascia Plates (1/2" x 5 1/2" x 8") x 2 Fascia Detail Plates (1/2" x 3 1/2" x 8") x 2 Horizontal Gable Plates (1/2" x 4 1/2" x 8") x 2	<u>Hardware</u> 1 1/2" Finishing Nails x 24 total
---	--

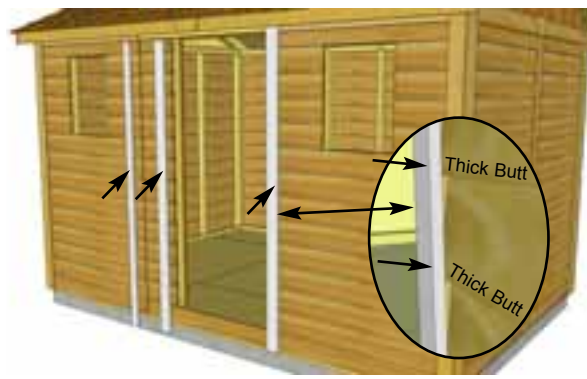
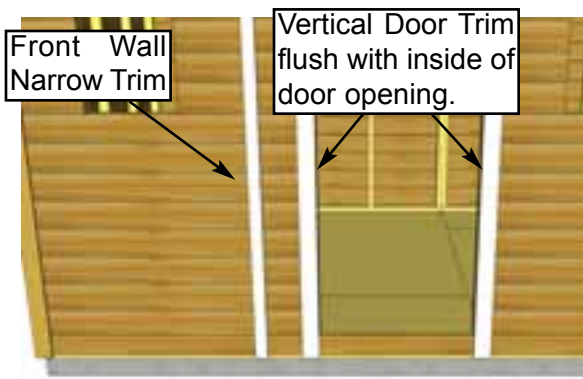

E14. Position **Vertical Door Trim** pieces flush with inside edge of Door opening and tight to soffits on top. Position **Front Wall Narrow Trim** evenly on seam where Narrow Wall and Window Wall come together. Attach with **8 - 1 1/2" Finishing Nails** per piece. Nail into the thick butt of the bevel siding.

<u>Parts</u>	<u>Hardware</u>
Vertical Door Trim (1/2" x 3 1/2" x 79") x 2 Front Wall Narrow Trim (1/2" x 2 1/2" x 79") x 1	1 1/2" Finishing Nails x 24 total



E15. Attach **Horizontal Door Trim** with **4 - 1 1/2" Finishing Nails** and **Horizontal Narrow Wall Trim** with **2 - 1 1/2" Finishing Nails** to cover Door Header.

<u>Parts</u>	<u>Hardware</u>
Horizontal Door Trim (1/2" x 1 1/4" x 32") x 1 Horizontal Narrow Wall Trim (1/2" x 1 1/4" x 7") x 1	1 1/2" Finishing Nails x 6 total

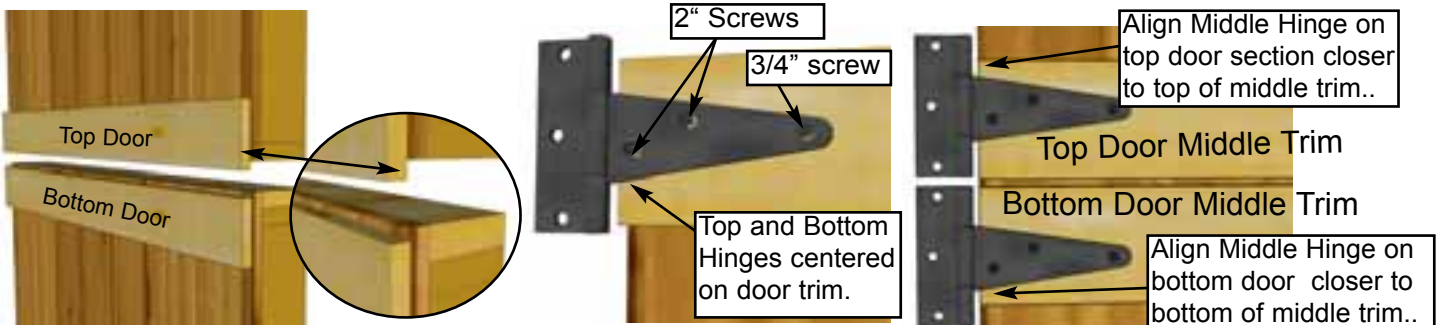

E16. Attach Door Hinges to **Top** and **Bottom Dutch Door** sections. Top Door section has middle trim overhanging door at bottom while bottom door section has middle trim recessed slightly. Top and Bottom Hinges should be centered on door trim. Align the middle hinge for the top door section closer to the top of the middle door trim. Align the middle hinge for the bottom door section closer to the bottom of the middle door trim. Middle hinges should not overlap. Position middle hinges accordingly. Use **2" & 3/4" Black Headed Screws** as shown above.

<u>Parts (Steps E16 - E18)</u>	<u>Hardware (Steps E16 - E18)</u>
Dutch Door - Top (31 1/2" x 30") x 1 Dutch Door - Bottom (31 1/2" x 42") x 1	Tee Hinges x 4 total 3/4" Black Screws x 4 total 2" Black Screws x 20 total

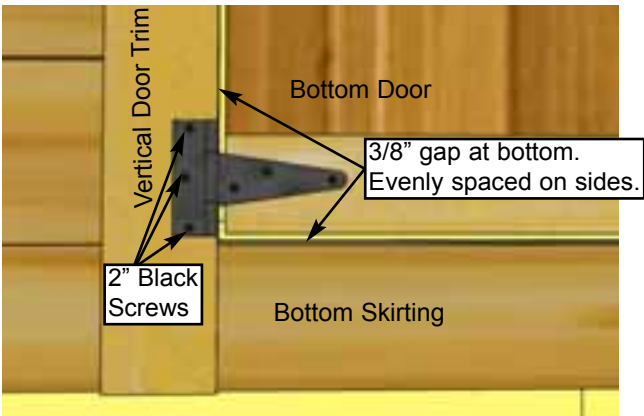

E17. Place Bottom Dutch Door panel into position. Gap 3/8" on bottom, evenly space on sides, and attach hinge to doorway seam trim with **2" Black Headed Screws**. Use shim to help keep the door evenly spaced on bottom. One of the extra roof shingles (see parts list) can be used.

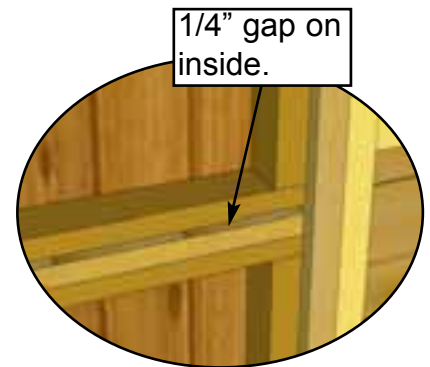
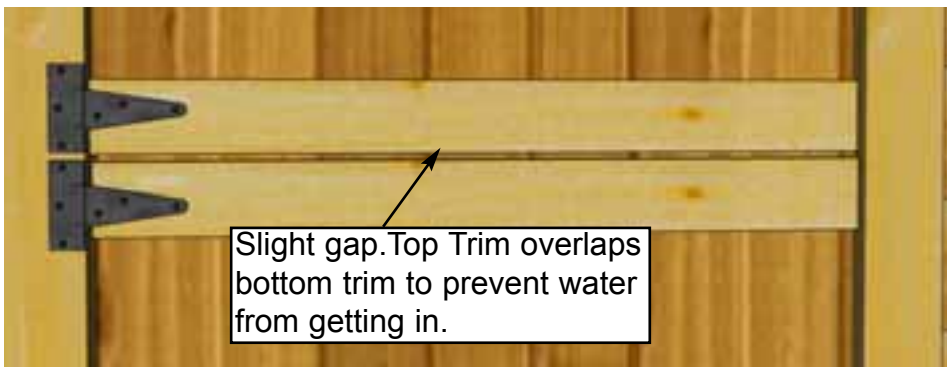

E18. Place the Top Dutch Door Panel into place and gap top and bottom trims on the outside about 1/8" apart. On the inside, horizontal door frames should be about 1/4" apart. Use a shim once again to help you. Attach hinges to trim with **2" Black Headed Screws** provided.

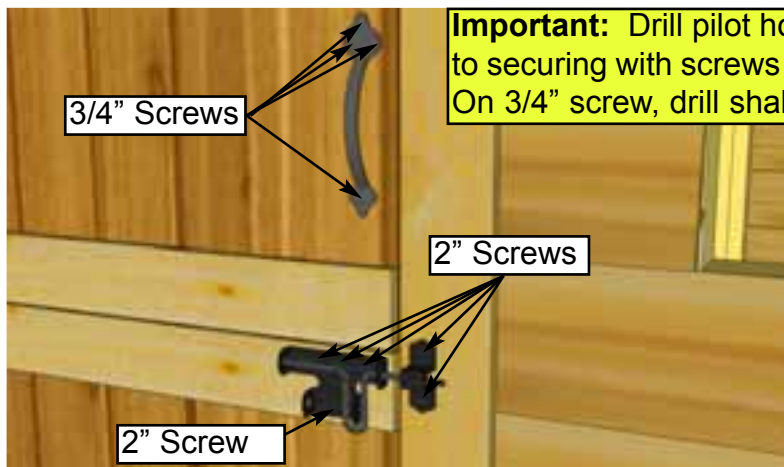

Important: Drill pilot holes with 1/8" drill bit prior to securing with screws to prevent wood splitting. On 3/4" screw, drill shallow pilot hole only.

E19. Attach **Door Handle** and **Exterior Black Drop Latch** to door. Handle is positioned on top door, Drop Latch on bottom door. Attach Black Drop Latch as illustrated above with **2" & 3/4" Black Screws**. **Note** how female part of Drop Latch is positioned higher than male. Do a dry run first to position Drop Latch correctly. Attach Handle with **2" Screws**, ensure screws connect with inner door stud.

Hardware
Door Handle x 1 total
Drop Latch x 1 total
3/4" Black Screws x 4 total
2" Black Screws x 6 total

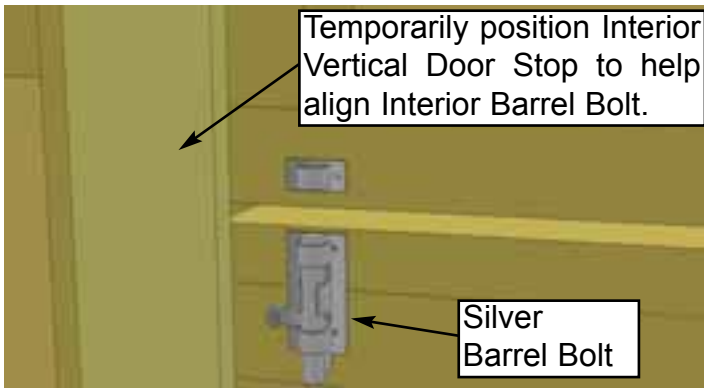

E20. Attach Interior Silver Barrel Bolt to inside of door as illustrated above. Use 3/4" Silver Screws to secure. Refer to Step E21 to allow for adequate clearance.

<u>Hardware</u>
Silver Barrel Bolt x 1 total
3/4" Silver Screws x 6 total

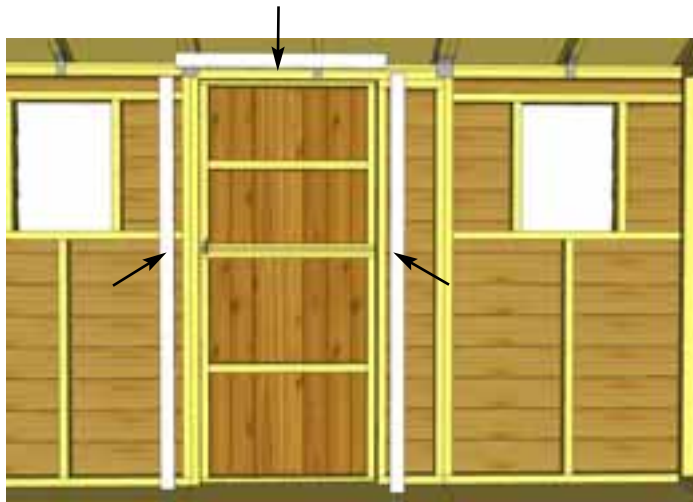

E21. Attach Interior Door Stops to door framing (Jambs and Header). Start with Vertical Door Stops. Stops should overlap doorway by 1/2". Use 4 - 1 1/4" Screws to secure each piece. Attach Horizontal Door Stop next using 3 - 1 1/4" Screws.

<u>Parts</u>	<u>Hardware</u>
Vertical Door Stops (1/2" x 2 1/2" x 72") x 2	1 1/4" Screws x 11 total
Horizontal Door Stop (1/2" x 2 1/2" x 36") x 1	

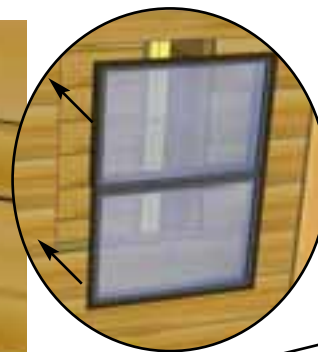
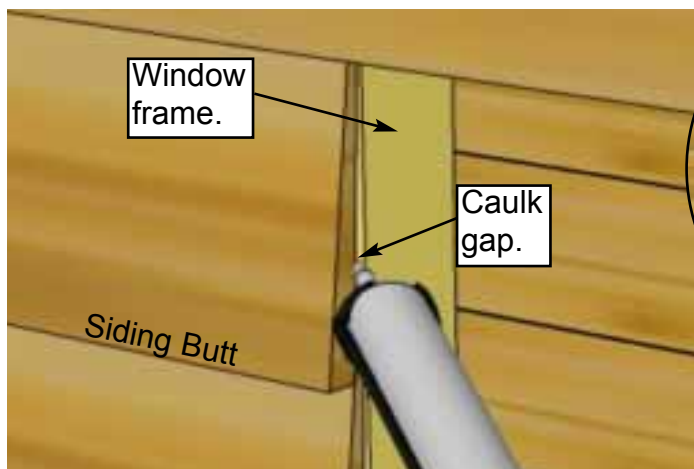

Screw insert into bottom (thick) part of siding.



E22. To reduce possible water from penetrating into the window cavity, caulk gap on both sides of window opening prior to installing Window Insert. Position insert in cavity and screw with 6 - 1 1/4" Screws. On sides, make sure to screw insert into the thick butt of the siding only.

<u>Parts</u>
Window Inserts x 2
<u>Hardware</u>
1 1/4" Screws x 12 total

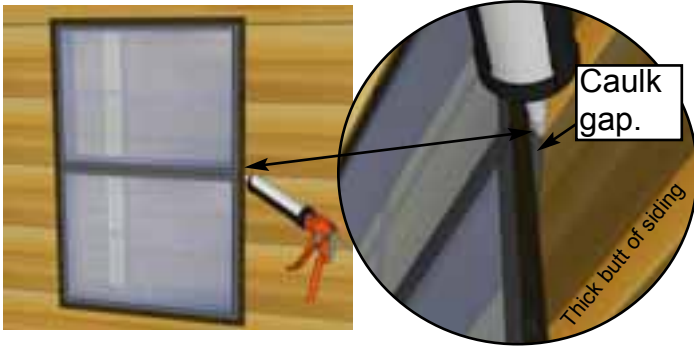

E23. Once Insert is attached, caulk the “triangular gap” between the Insert’s outside flange and the siding. Also put a bead of caulking horizontally at top of window where the flange and siding meet. This additional caulking will also will reduce the chances of moisture entering into your shed.

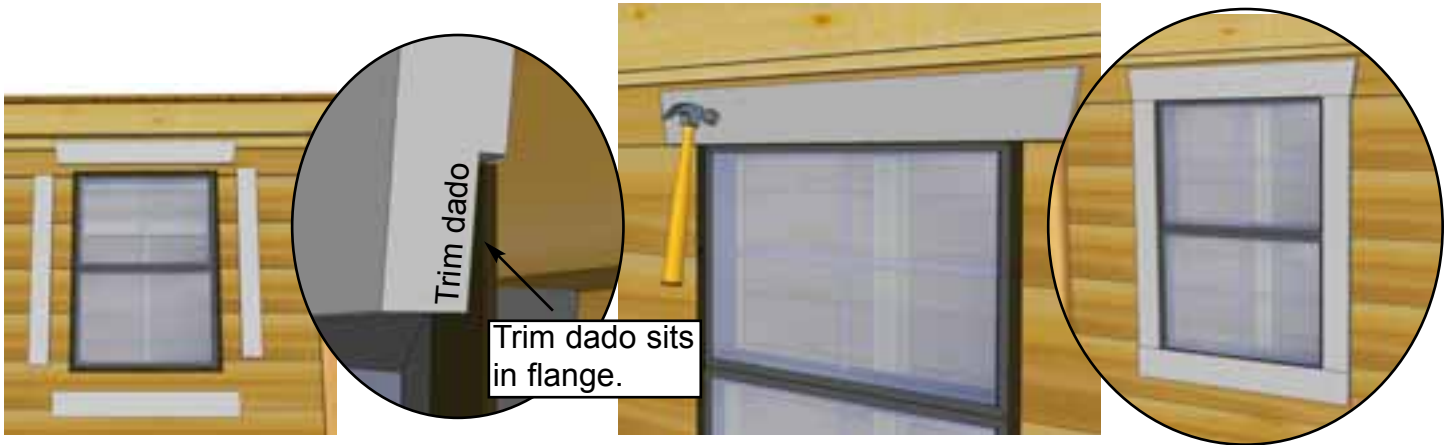

E24. Position **Window Trim** around window doing a dry run first and attach with **4 - 1 1/2” Finishing Nails** per piece. Window trim has a small dado on reverse face. Outside flange of window will roughly sit in the dado to give a better fit.

<u>Parts</u>	<u>Hardware</u>
Window Trim Package x 2 (Top - 24 1/16” Long - Angle Cut Ends) x 1 (Sides & Bottom - 23” Long) x 3	1 1/2” Finishing Nails x 32 total



E25. Assemble **Flower Box** with Assembly Instructions included on Page 42. Position completed Flower Box below bottom of window trim and secure with **2 - 2” Screws** per box. Screw from inside of box into the center Window Wall stud. Attach second screw 2” underneath first screw and once again into the wall stud. Install Flower Box Kits underneath each window.

<u>Parts</u>	<u>Hardware</u>
Flower Box Kits x 2	2” Screws x 4 total



Outdoor Living Today Flower Box Assembly Instructions

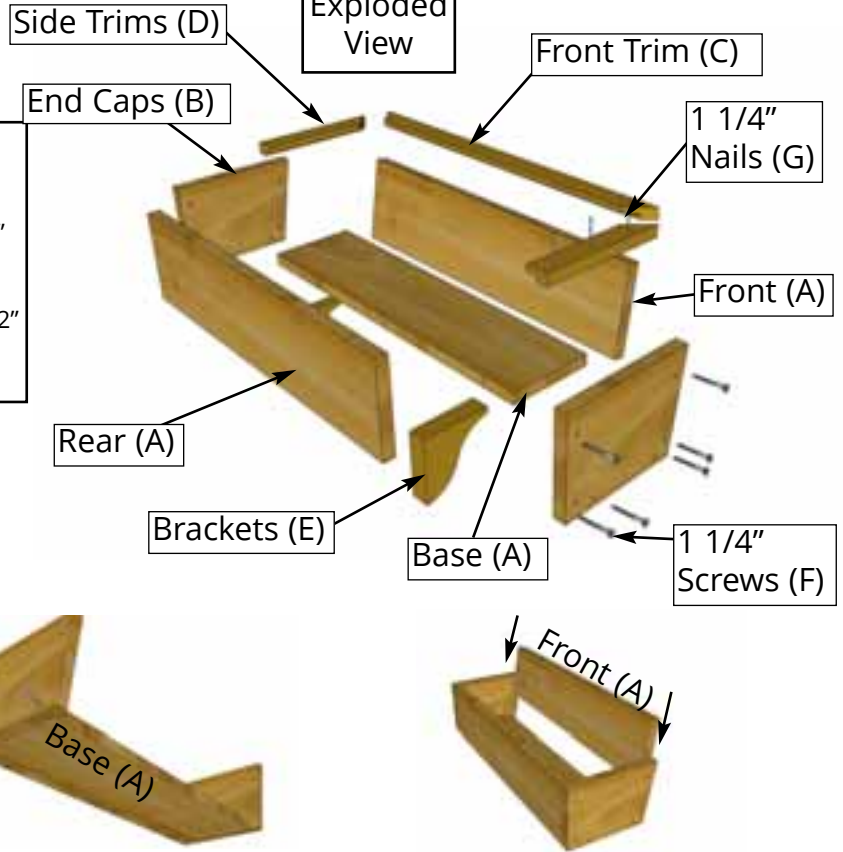

Parts Lists:

A - Base, Rear & Front Box Frames (3pcs)	3/4" x 5 1/2" x 23"
B - End Cap Frames (2pcs)	3/4" x 5 1/2" x 7" / 8"
C - Front Trim (1 pc)	3/4" x 1 1/2" x 26"
D - Side Trims (2 pc)	3/4" x 1 1/2" x 8 3/4"
E - Brackets (2 pc)	1 1/2" x 5 1/2" x 5 1/2"
F - 1 1/4" Screws (15 pc)	
G - 1 1/2" Nails (10 pc)	

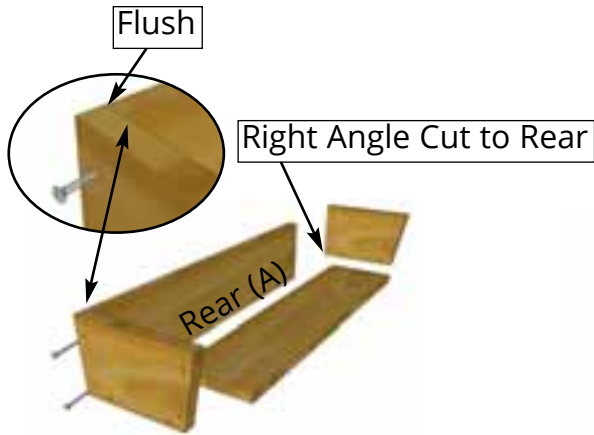

1. On a table position Rear Box and End Cap Frames together so flush at top. Fasten together with 2 - 1 1/4" screws. Place Base Frame tight against Rear and End Cap and flush at bottom. Secure with 2 - 1 1/4" screws. Complete attachment of remaining End Cap Frame. Slide Front Frame between End Caps.

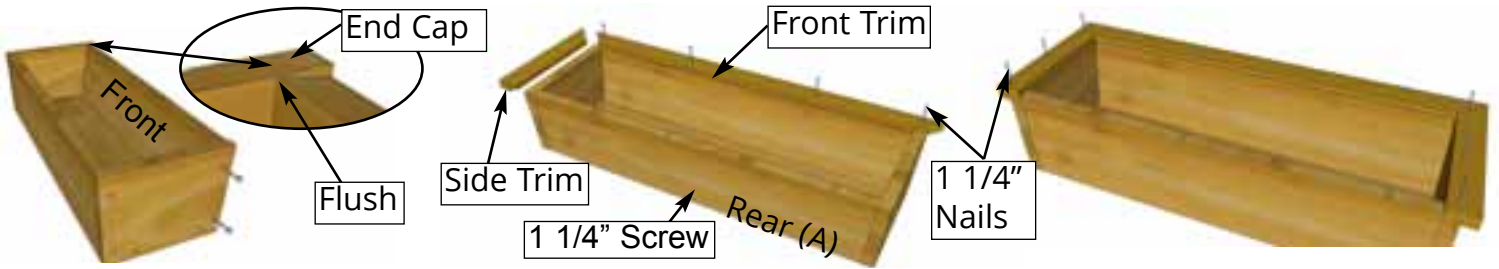

2. Position Front Frame Piece flush with End Cap. Attach both ends with 2 - 1 1/4" screws. Pilot hole Rear Box Frame near bottom center and secure to Base edge with 1 - 1 1/4" screw. Evenly position Front Trim (mitre cut on end and dado cut on inside bottom) tight against front frame and nail down with 4 - 1 1/4" nails. Position Side Trims as per Front and secure with 3 - 1 1/4" nails per side.

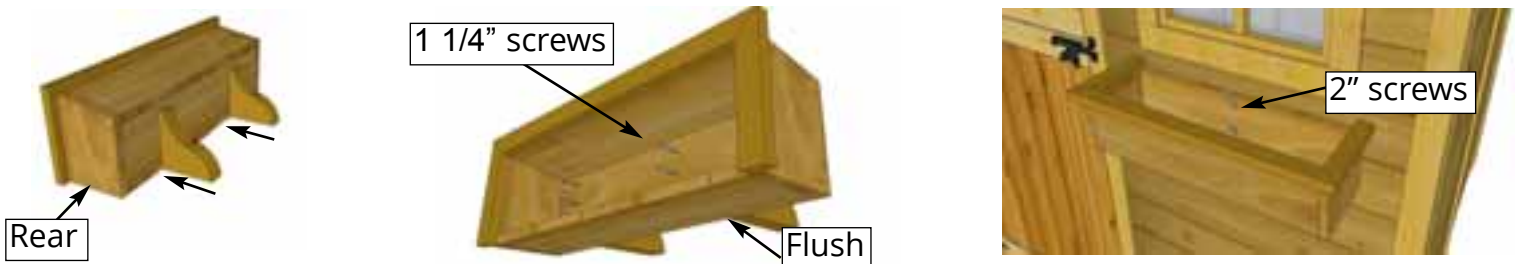

3. On a flat surface, flip Flower Box on it's rear face. Evenly space Brackets and secure through Base Frame and into the Brackets with 2 - 1 1/4" screws per Bracket. Position completed Flower Box beneath window trim and screw from inside of box into the center wall stud with 2 - 2" screws. (2" screws supplied with Base Kit.)



Outdoor Living Today

Congratulations on assembling your 12x8 Cabana!

Note: Our Sheds are shipped as an unfinished product. If exposed to the elements, the lumber will weather to a silvery-gray color. If you prefer to keep the lumber looking closer to the original color, we suggest that you treat the wood with a good oil base wood stain. You may also wish to paint your new shed rather than stain it. In both cases we recommend that you consult with a paint and stain dealer in your area for their recommendations.



We hope your experience constructing our **12x8 Cabana** has been both positive and rewarding. We value your feedback and would like to hear back from you on how well we are doing in the following areas:

- 1. Customer Service**
- 2. On Time Shipping**
- 3. Motor Freight Delivery**
- 4. Quality of Materials**
- 5. Assembly Manual**
- 6. Overall Satisfaction**



The materials contained in this Assembly Manual may be downloaded or copied provided that ALL copies retain the copyright and any other proprietary notices contained on the materials. No material may be modified, edited or taken out of context such that its use creates a false or misleading statement or impression as to the positions, statements or actions.

Please call, write or email us at:

Canadian Address
9393 287th Street
Maple Ridge, British Columbia
Canada V2W 1L1

United States Address
P.O. Box 96
Sumas, Washington
USA 98295

Toll Line: 1.888.658.1658

| Fax: 1.604.462.5333

| sales@outdoorlivingtoday.com

Toll Free 1-888-658-1658

www.outdoorlivingtoday.com

sales@outdoorlivingtoday.com