

INSTALLATION

Product Manual

Description du produit

Version: 020434CA-01-24B-YQ

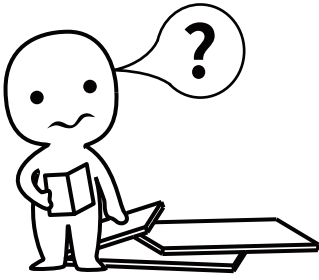

IMPORTANT INFORMATION!

please read the entire manual before starting to assemble and/or using this product. follow the manual thoroughly and keep it for further reference.

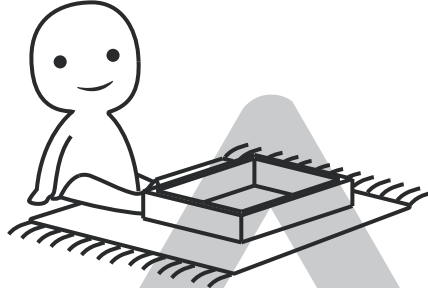
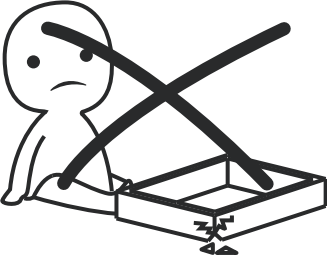

AVOID SCRATCHES!

In order to avoid scratching this furniture should be assembled on a soft layer- could be a rug.

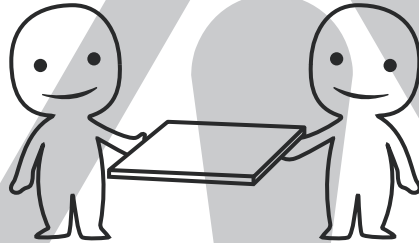

IMPROVE EFFICIENCY !

Try to find a partner to install with you, which can speed up the installation efficiency and shorten the time.

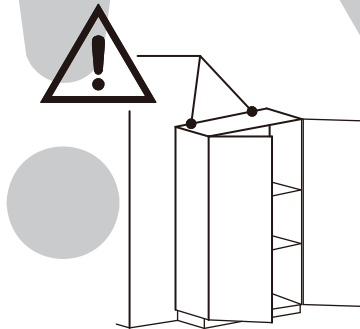
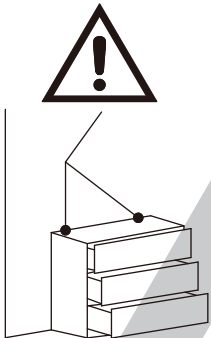

ANTI-TOPPLE WARNING !

Overturnd furniture can cause serious or fatal crush injuries. To prevent tipping over, be sure to use the wall attachment, if not included with this product. Please purchase the wall attachment that fit your wall. If unsure, seek professional advice. Please read and follow each step of the instructions carefully.

IMPORTANT !

It is important that any product which is assembled using any kind of screw is re-tightened 2 weeks after assembly, and once every 3 months - in order to assure stability through-out the lifespan of the product.

For regular maintenance and cleaning of the product, for the frame, please use a rag dipped in neutral detergent to fully wipe it, and then dry it with a clean rag. For glass materials, wipe with a rag dampened with water glass cleaner, and then dry with a dry rag.

Do not use an electric screwdriver, and do not use too much force when installing, because the board is easy to break.

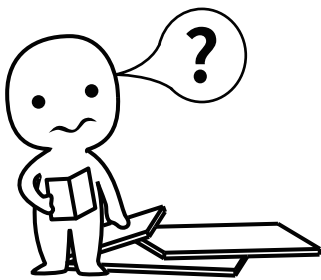

AVERTISSEMENT!

Veillez lire le manuel en entier avant de commencer à assembler et/ou à utiliser ce produit. Suivez attentivement le manuel et conservez-le pour référence ultérieure.

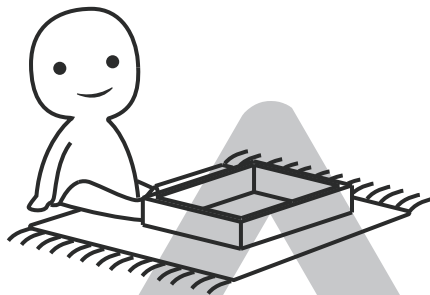
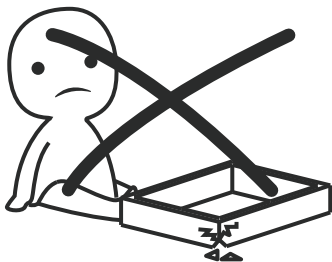

ÉVITEZ LES RAYURES!

Afin d'éviter de rayer ce meuble doit être assemblé sur une couche souple - pourrait être un tapis.

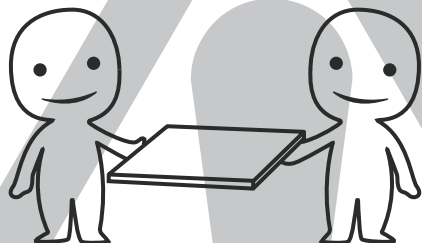

AMÉLIORER L'EFFICACITÉ !

Essayez de trouver un partenaire à installer avec vous, ce qui peut accélérer l'efficacité de l'installation et raccourcir le temps.

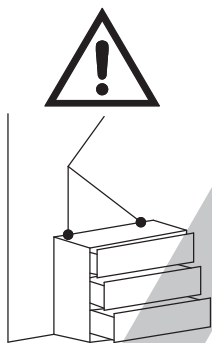

AVERTISSEMENT ANTI-RENVERSEMENT !

Les meubles renversés peuvent causer des blessures graves ou mortelles par écrasement. Pour éviter de basculer, assurez-vous d'utiliser la fixation murale, si elle n'est pas incluse avec le produit. Veillez acheter la fixation murale qui s'adapte à votre mur. En cas de doute, demandez conseil à un professionnel. Veillez lire et suivre attentivement chaque étape des instructions.

IMPORTANT !

Il est important que tout produit assemblé à l'aide de tout type de vis soit resserré 2 semaines après l'assemblage et une fois tous les 3 mois, afin d'assurer la stabilité tout au long de la durée de vie du produit.

Pour l'entretien régulier et le nettoyage du produit, pour le cadre, veuillez utiliser un chiffon trempé dans un détergent neutre pour l'essuyer complètement, puis séchez-le avec un chiffon propre. Pour les matériaux en verre, essuyez avec un chiffon imbibé d'eau nettoyant pour vitres, puis séchez avec un chiffon sec.

N'utilisez pas de tournevis électrique et n'utilisez pas trop de force lors de l'installation, car la carte est facile à casser.

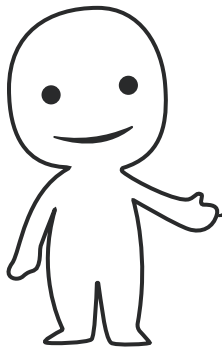

Please prepare the following tools

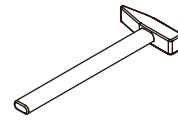
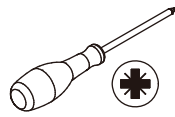

When installing, please carefully confirm whether each screw corresponds to the manual, accessories with similar shapes can be distinguished by size

A x 26

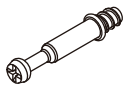

Ø6 x 35 mm

B x 26



Ø15 x 12 mm

C x 14

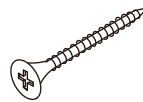

Ø4 x 35 mm

D x 18

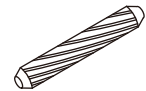

Ø6 x 30 mm

E x 6

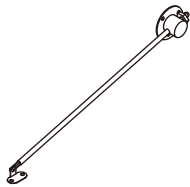

F x 78

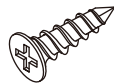

Ø3.5 x 12 mm

G x 8

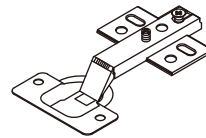

H x 10

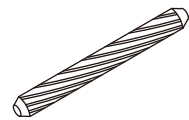

Ø6 x 50 mm

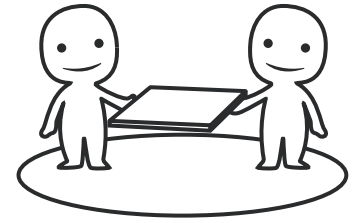

ASSEMBLED BY 2 ADULTS
ASSEMBLÉ PAR 2 ADULTES

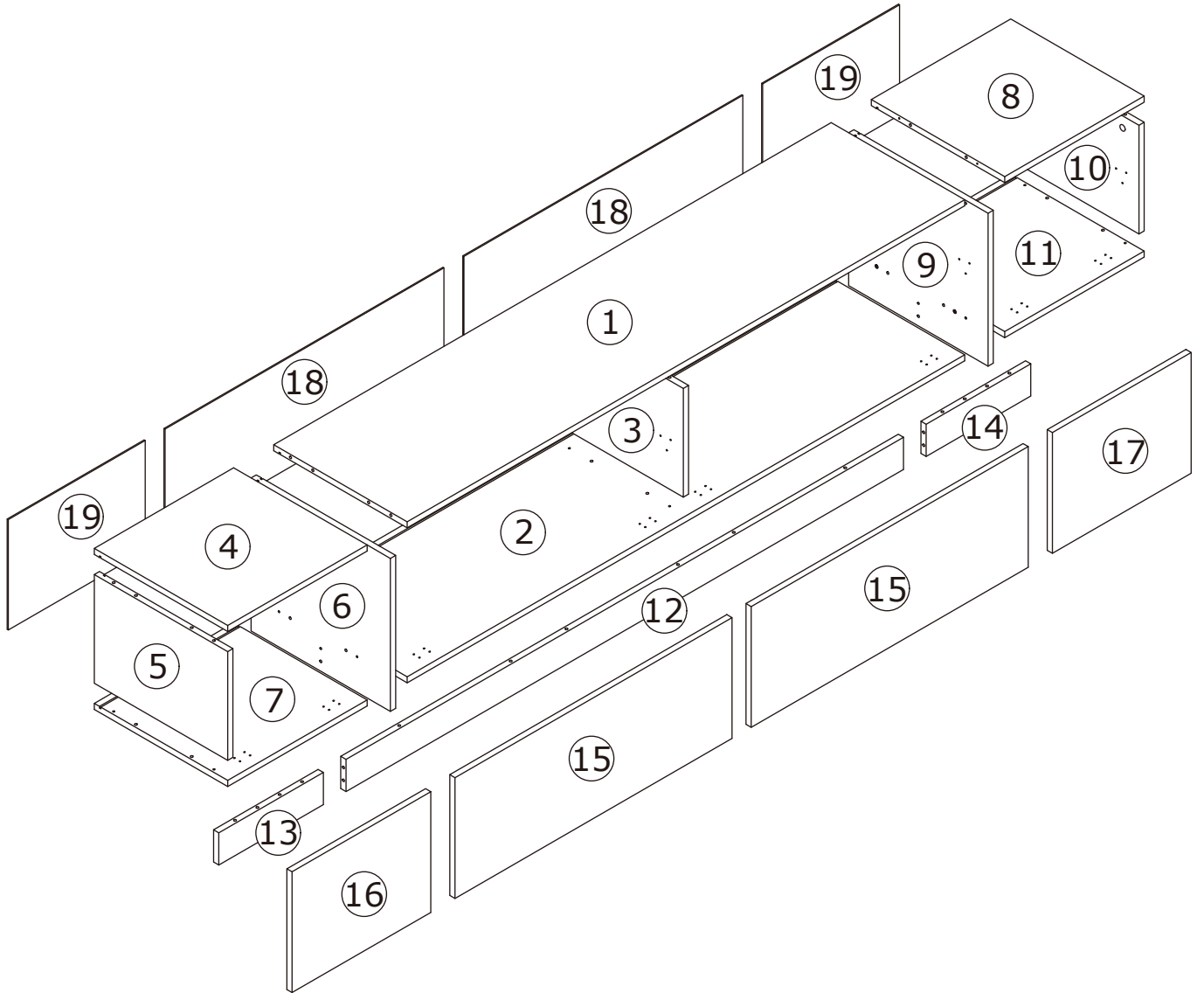

1

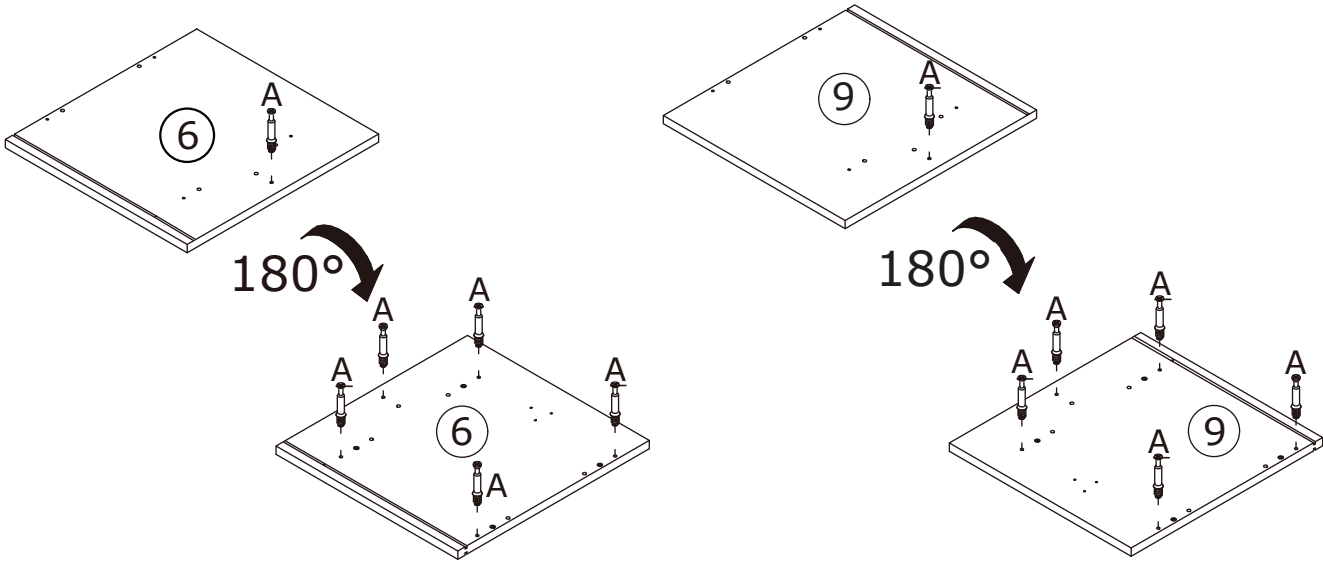
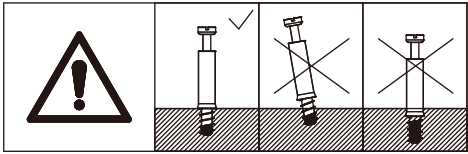
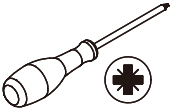

Screw eccentric rod(A) into board 4, 6, 7, 8, 9 and 11 with a screwdriver as shown.

Visser la tige excentrique (A) dans la planche 4, 6, 7, 8, 9 et 11 à l'aide d'un tournevis comme indiqué.

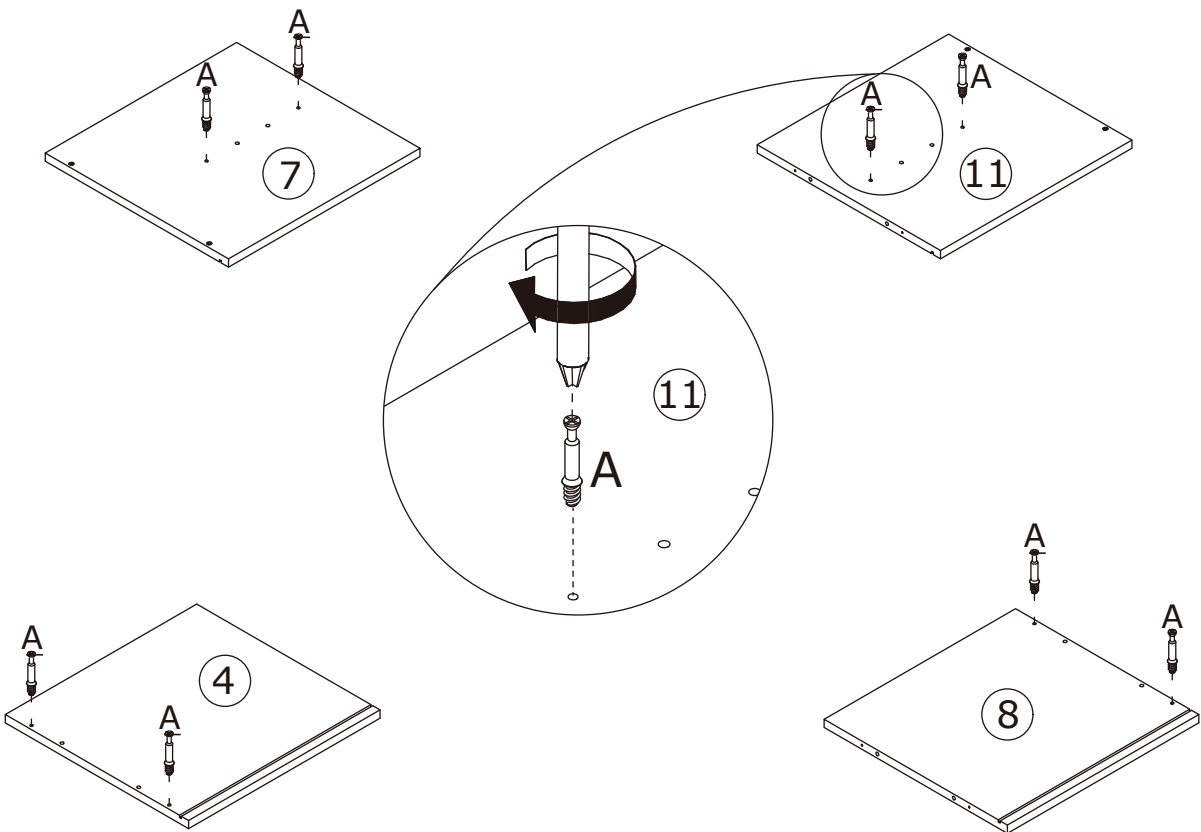

2

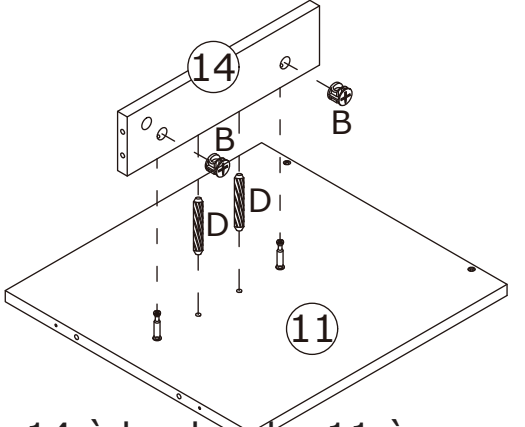
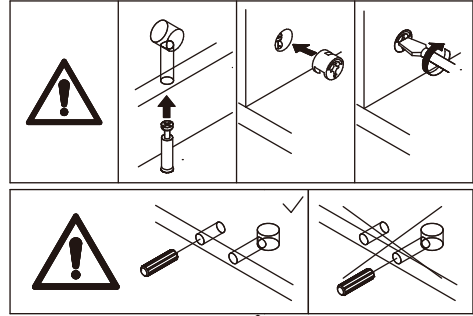
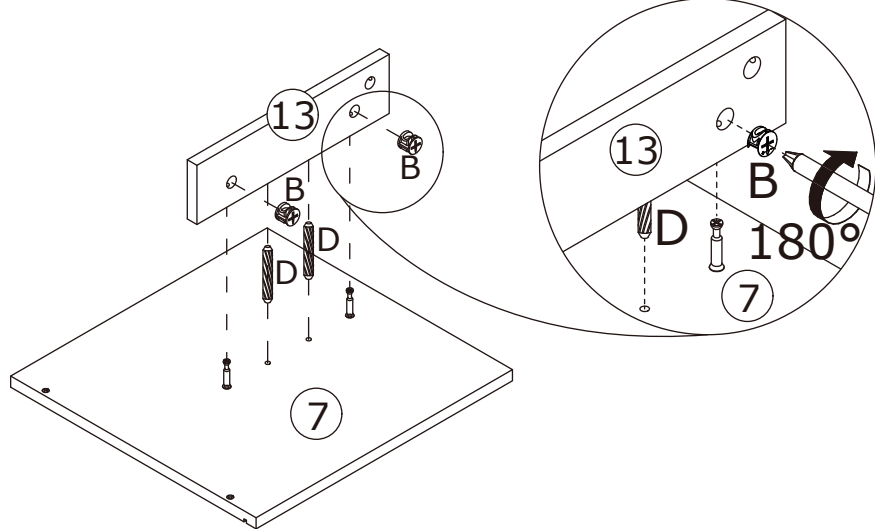
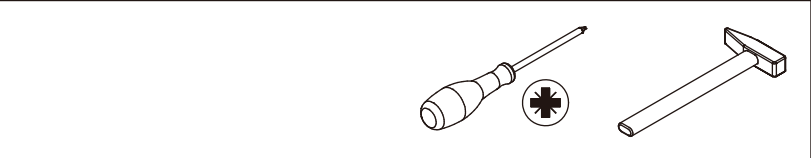
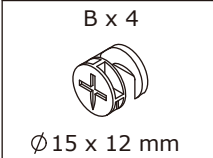

Connect board 13 to board 7; board 14 to board 11 using wooden dowel(D), add cam lock(B) into board 13,14 and turn clockwise to tighten as shown.

Relier la planche 13 à la planche 7 ; la planche 14 à la planche 11 à l'aide d'une cheville en bois (D), ajouter le verrou à came (B) dans la planche 13, 14 et tourner dans le sens des aiguilles d'une montre pour serrer comme indiqué.

3

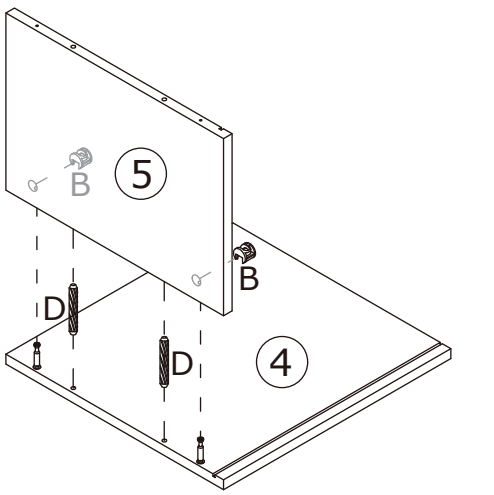
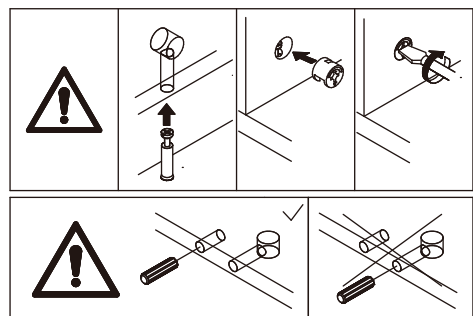
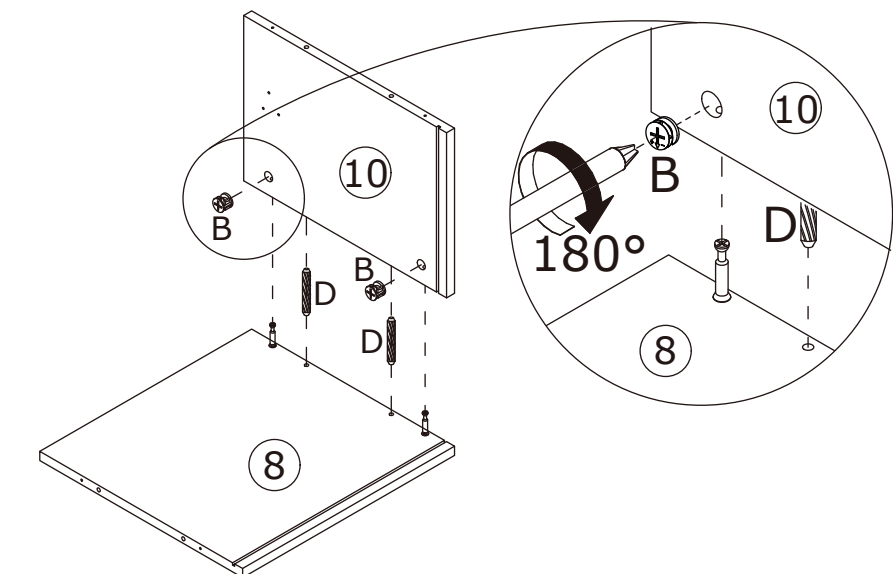
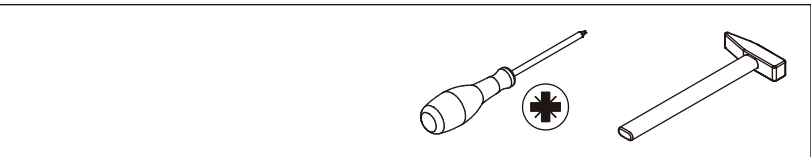
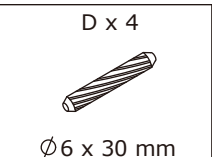
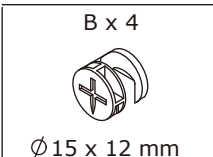

4

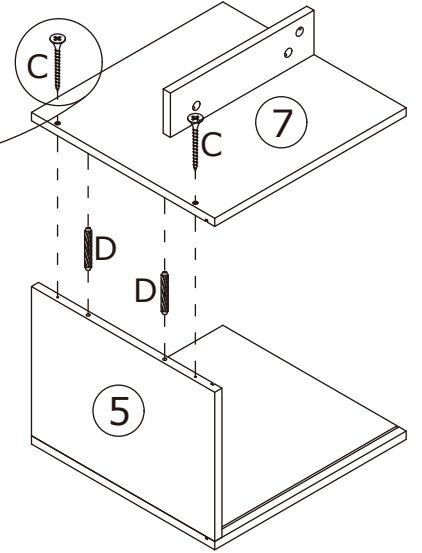
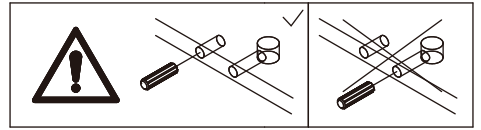
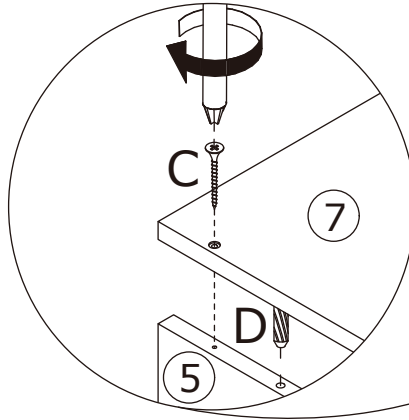
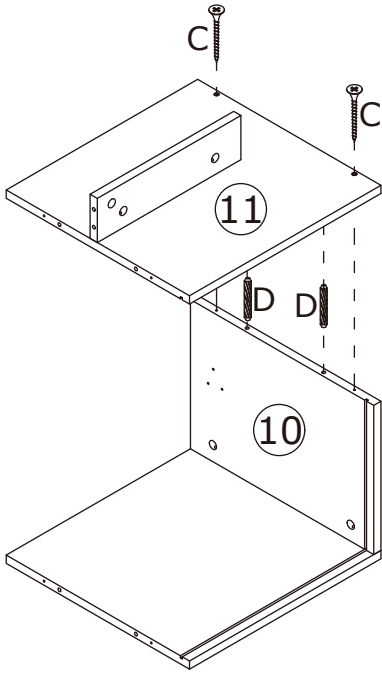
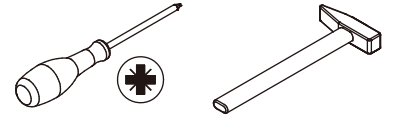

5



Insert back board 19 along grooves as shown.

Insérer le panneau arrière 19 le long des rainures comme indiqué.

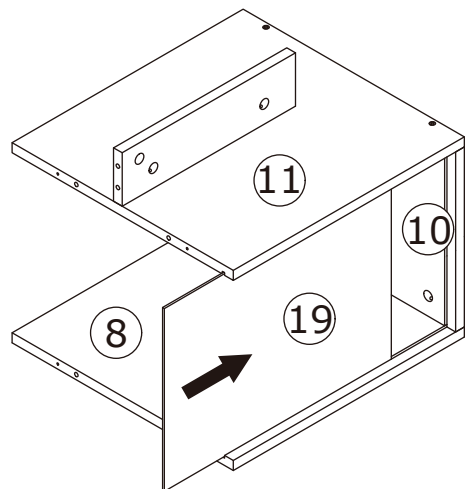
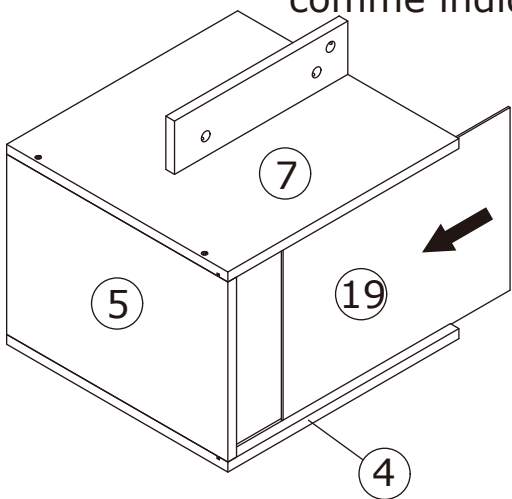

6

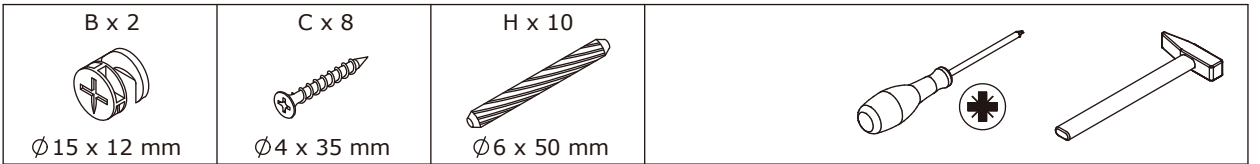

Fixer la planche 6 aux planches 4 et 7 à l'aide d'une **LONGUE** cheville en bois (H), et fixer avec une vis (C) comme indiqué. Ajoutez le verrou à came (B) dans la planche 13 et tournez dans le sens des aiguilles d'une montre pour serrer comme indiqué.

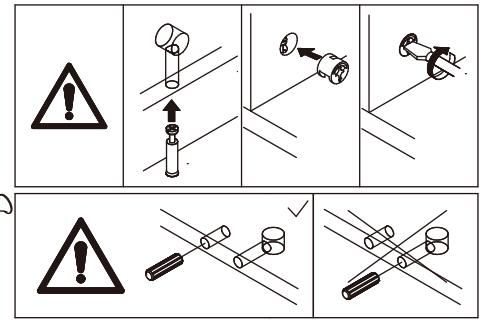
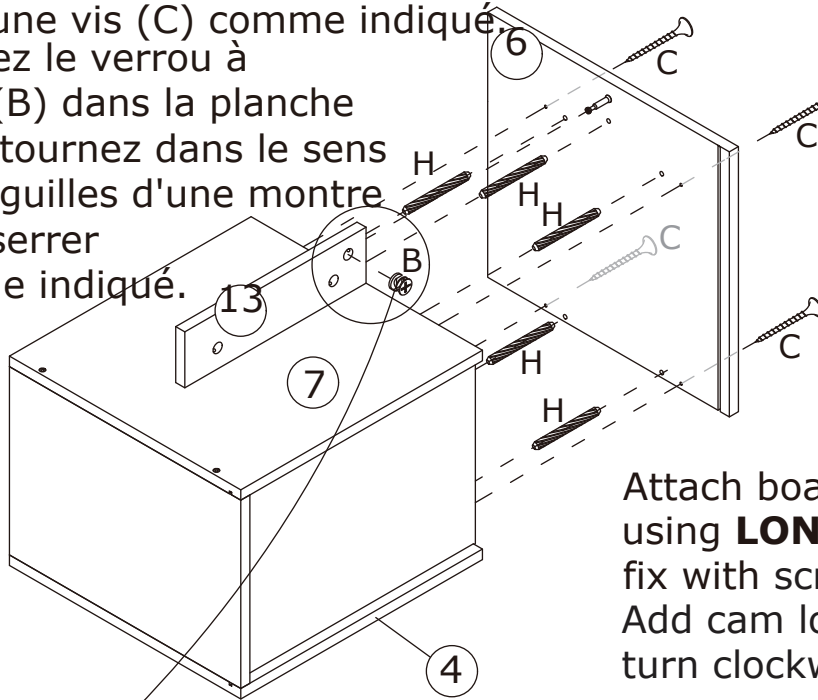

Attach board 6 to board 4 and 7 using **LONG** wooden dowel (H), and fix with screw (C) as shown. Add cam lock (B) into board 13 and turn clockwise to tighten as shown.

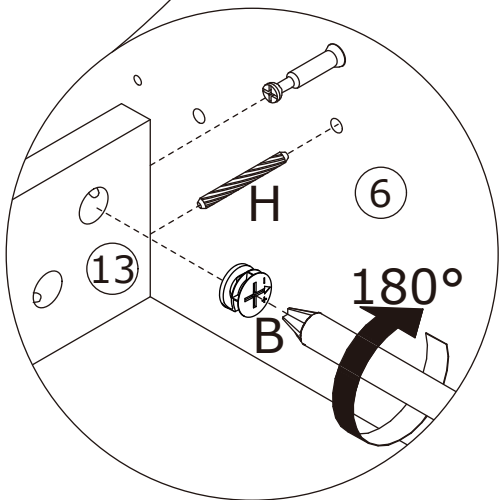

Attach board 9 to board 8 and 11 using **LONG** wooden dowel (H), and fix with screw (C) as shown. Add cam lock (B) into board 14 and turn clockwise to tighten as shown.

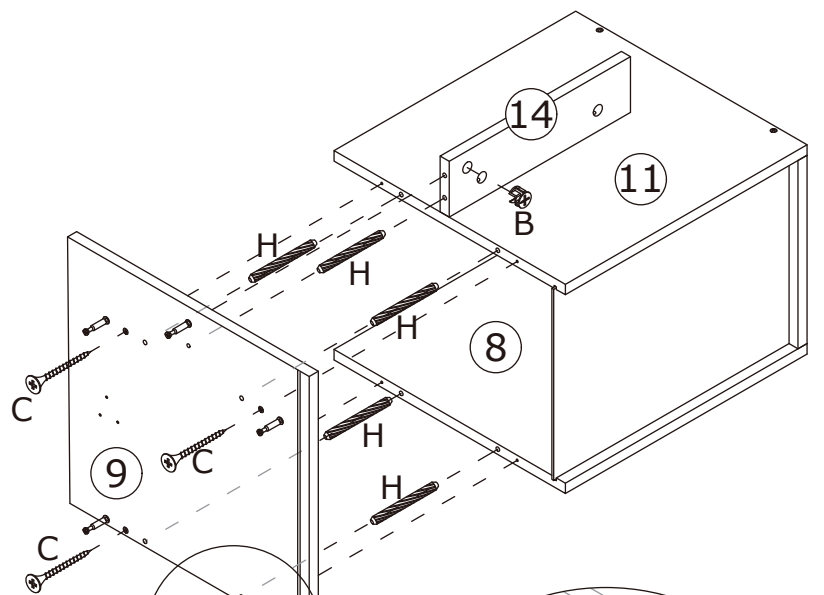

Fixer la planche 9 aux planches 8 et 11 à l'aide d'une **LONGUE** cheville en bois (H), et fixer avec une vis (C) comme indiqué. Ajoutez le verrou à came (B) dans la planche 14 et tournez à l'horloge pour serrer comme indiqué.

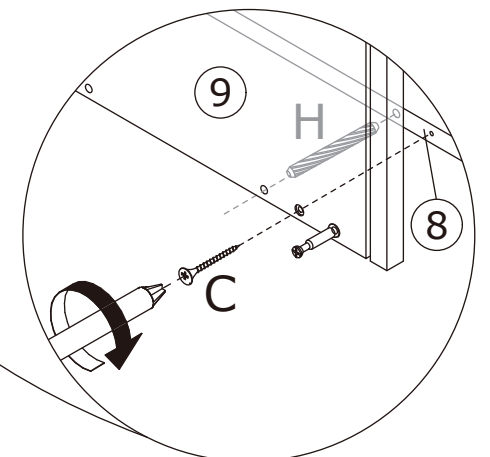

7

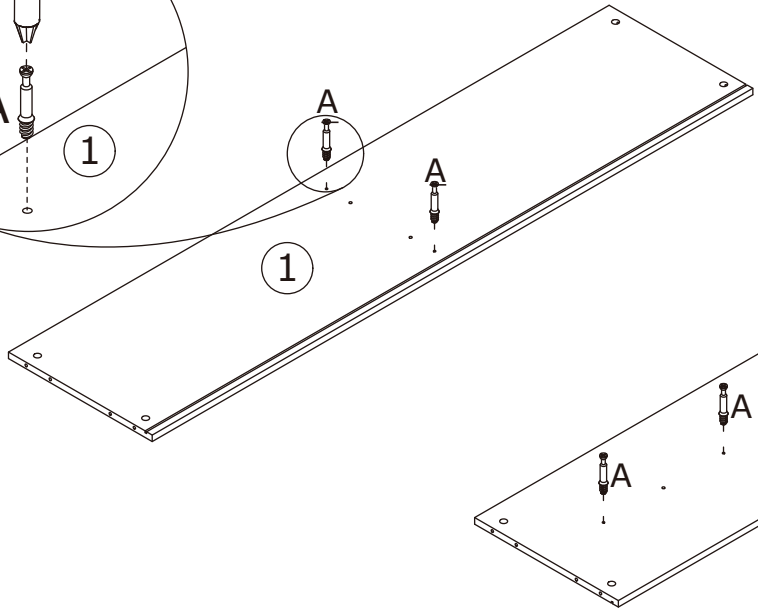
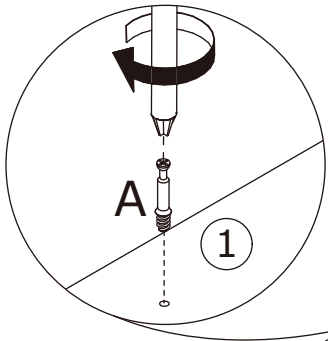
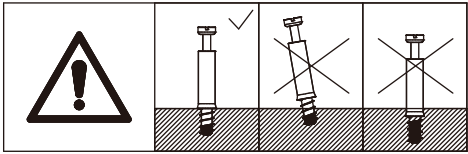
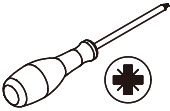

8

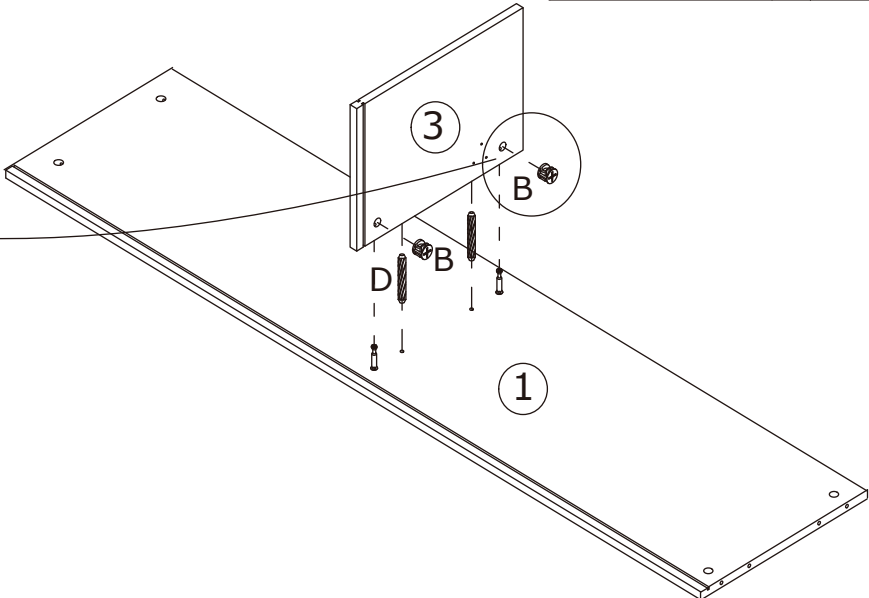
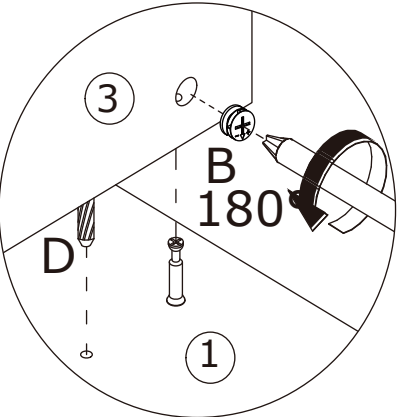
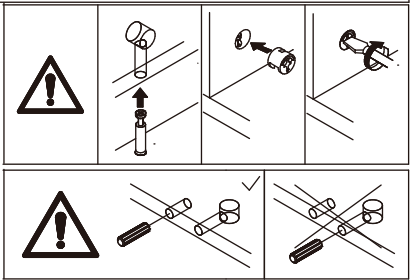
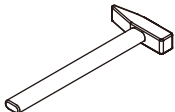
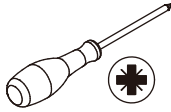
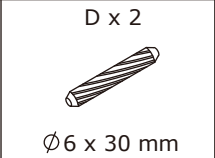
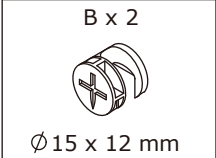

9

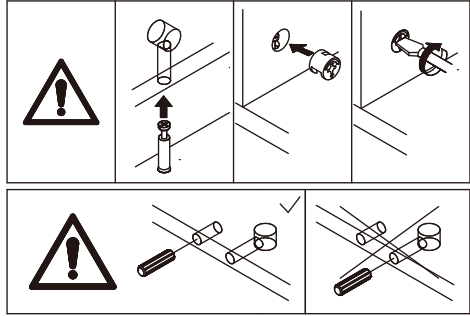
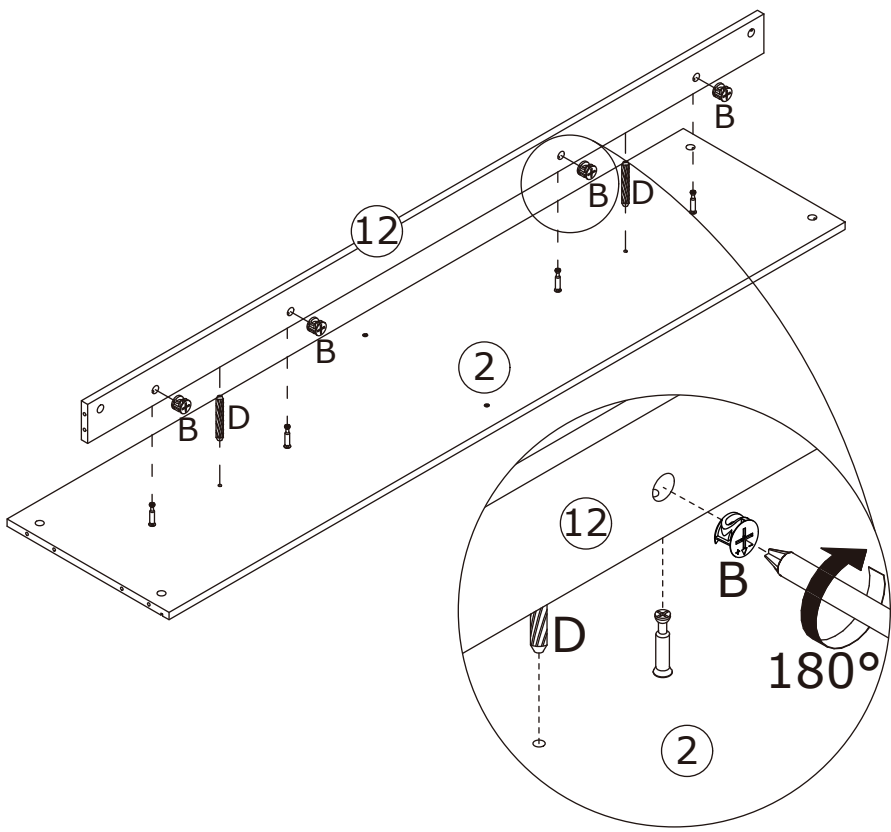
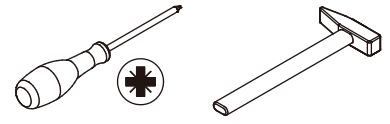
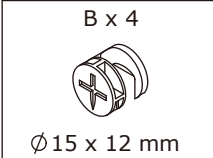

10

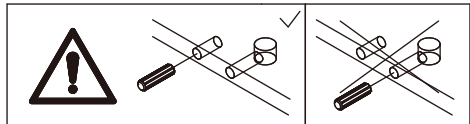
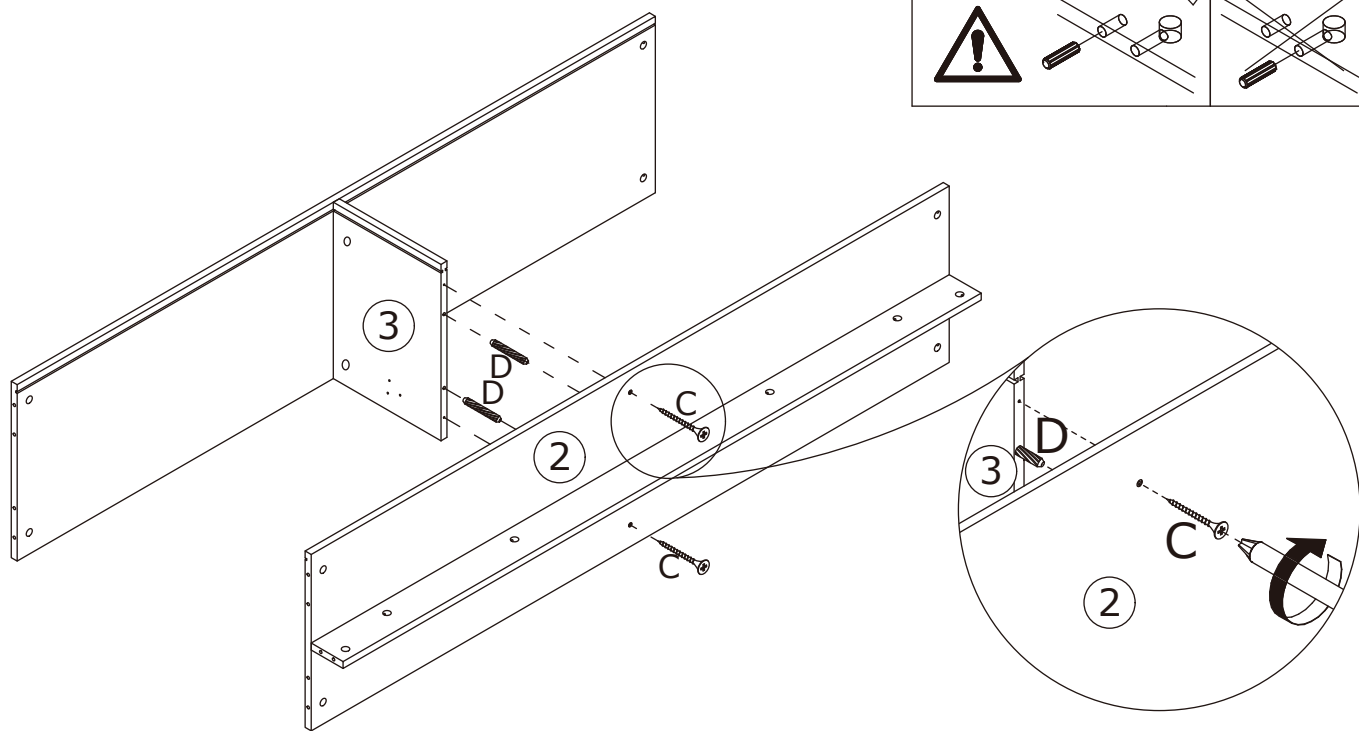
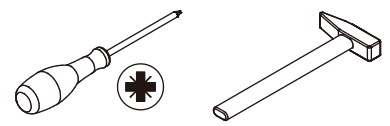
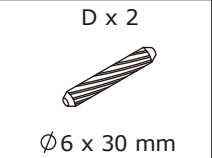
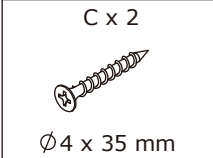

11

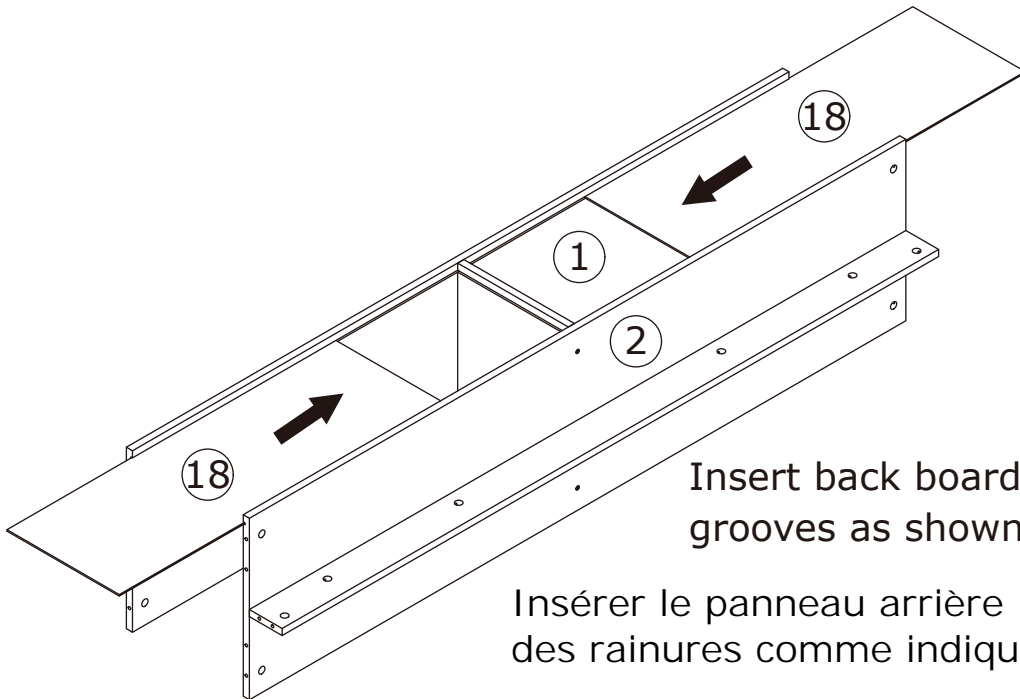

Insert back board 18 along grooves as shown.

Insérer le panneau arrière 18 le long des rainures comme indiqué.

12

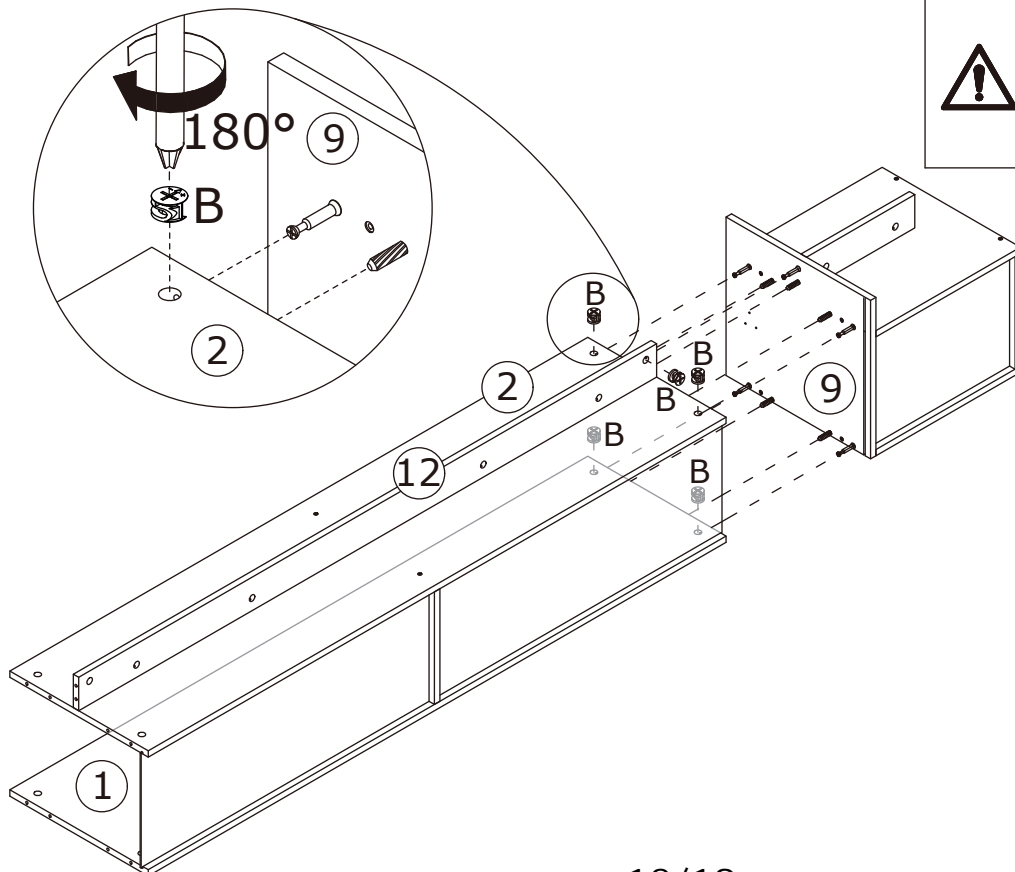
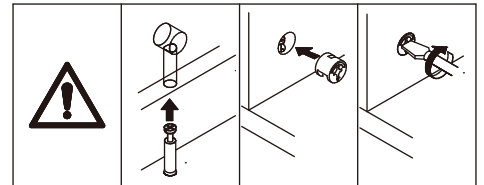
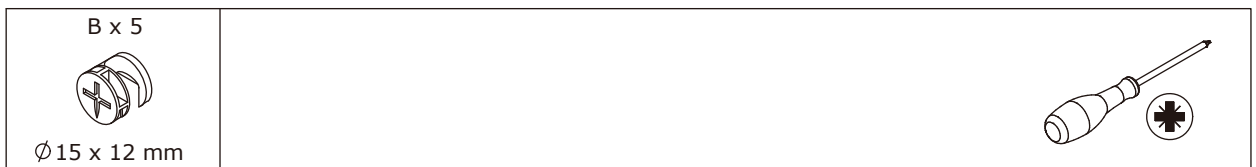

13

B x 5



Ø 15 x 12mm

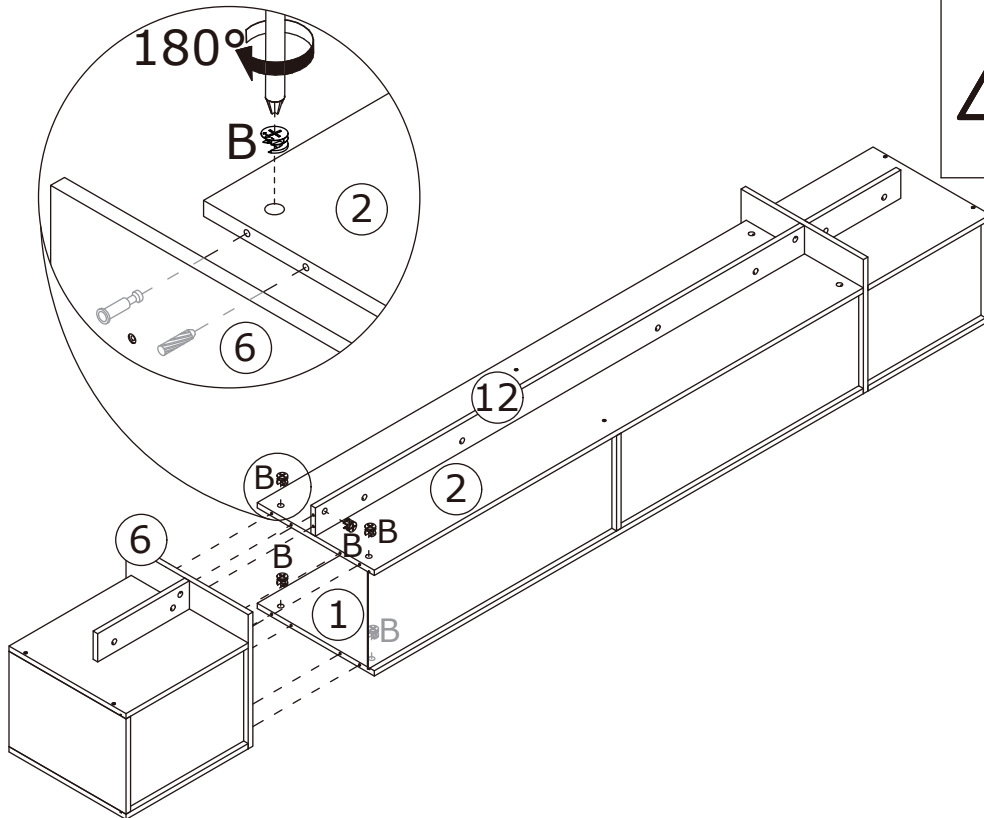
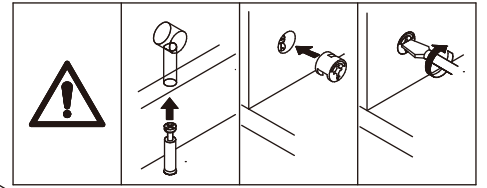
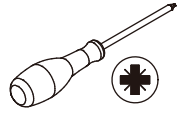

14

F x 16



Ø 3.5 x 12mm

G x 8

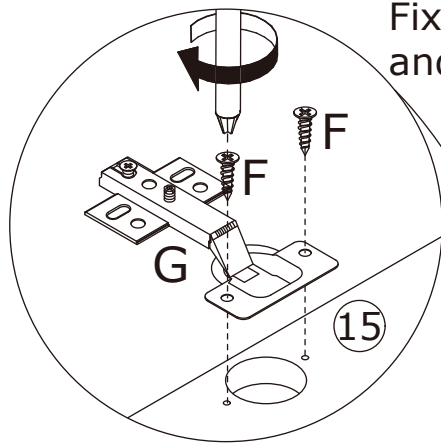
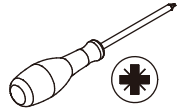
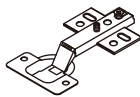

Fix hinge(G) to board 15, 16 and 17 with screw(F) as shown.

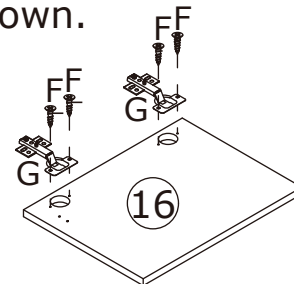

Fixer la charnière (G) aux panneaux 15, 16 et 17 à l'aide de la vis (F) comme indiqué.

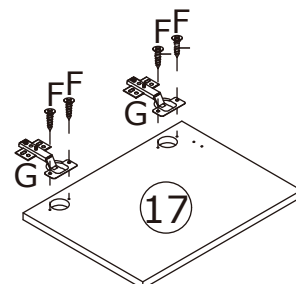
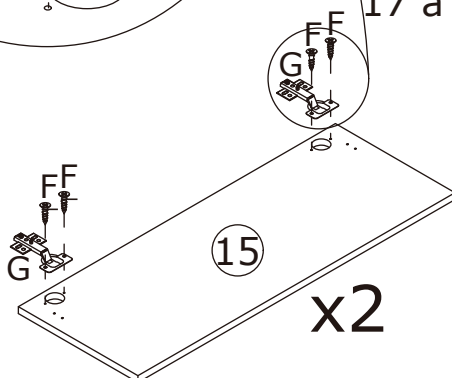

15

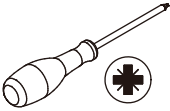
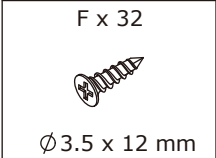

Assemble board 16 to board 7; board 15 to board 2; board 17 to board 11 by fixing hinge with screw(F) as shown.

Assembler la planche 16 à la planche 7 ; la planche 15 à la planche 2 ; la planche 17 à la planche 11 en fixant la charnière avec la vis (F) comme indiqué.

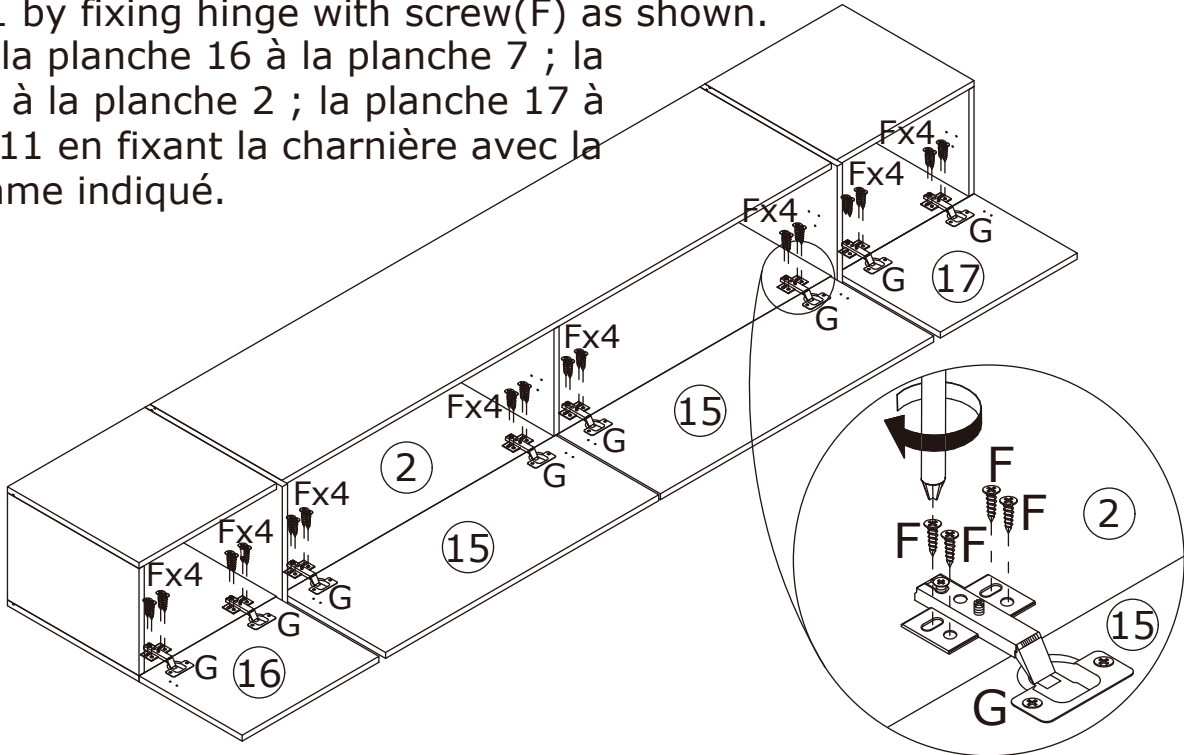

16

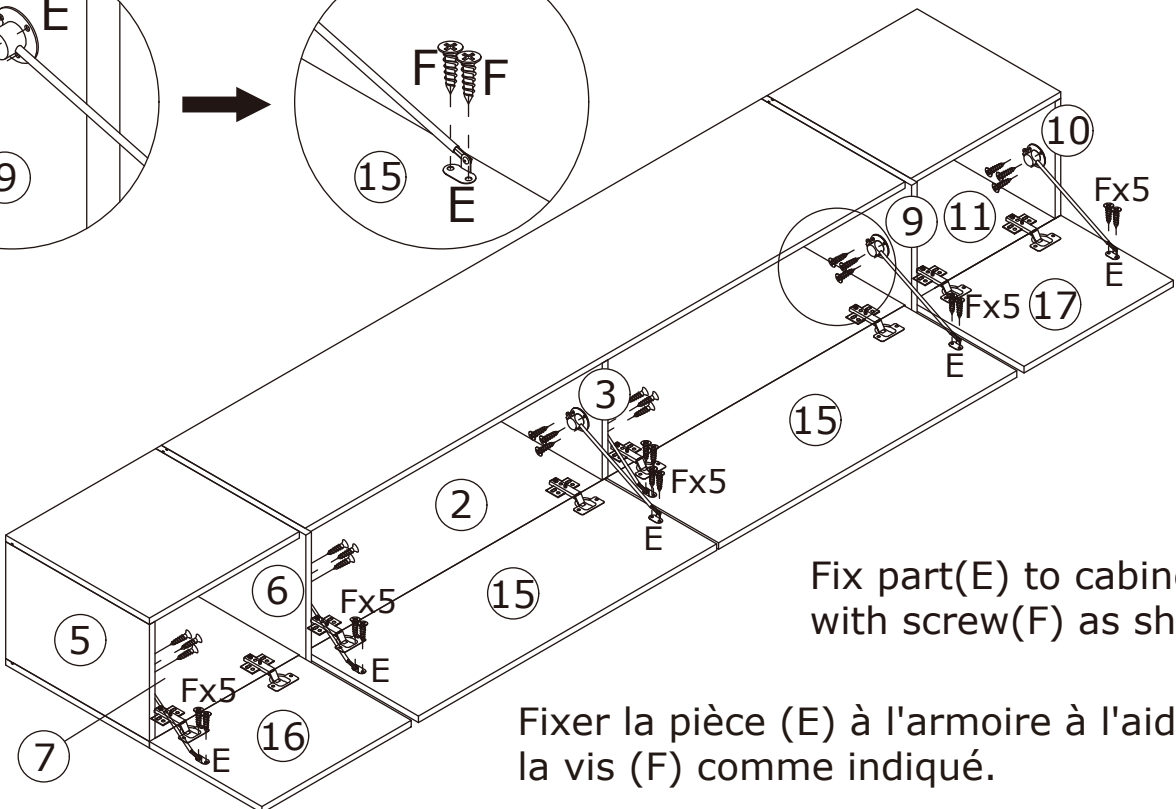
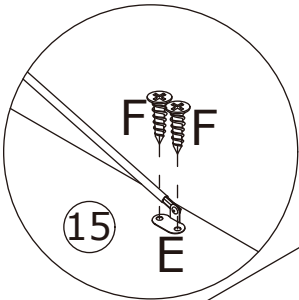
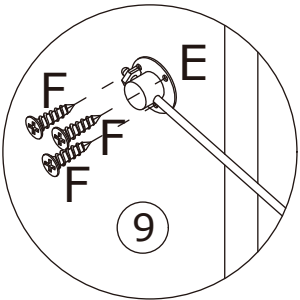
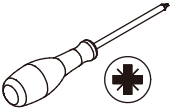
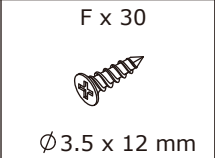
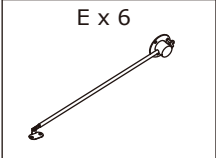

Fix part(E) to cabinet with screw(F) as shown.

Fixer la pièce (E) à l'armoire à l'aide de la vis (F) comme indiqué.

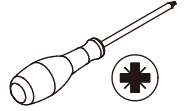

If there is misalignment after you install,
adjust the screw to the best condition
If doors are still not aligned if the hinges
are properly correctly, please watch the
video.

S'il y a un désalignement après l'installation,
ajustez la vis pour obtenir la meilleure
condition Si les portes ne sont toujours pas
alignées et que les charnières sont
correctement réglées, veuillez regarder la
vidéo.

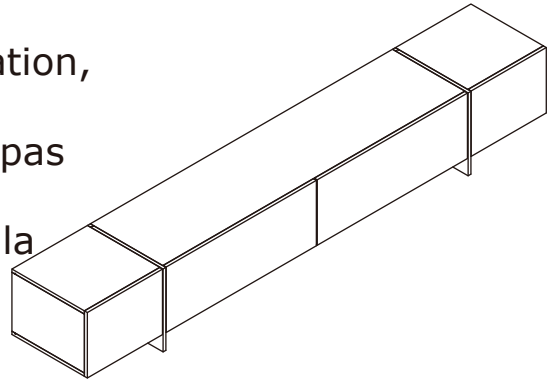

<https://youtu.be/n0Lb36SoODM>

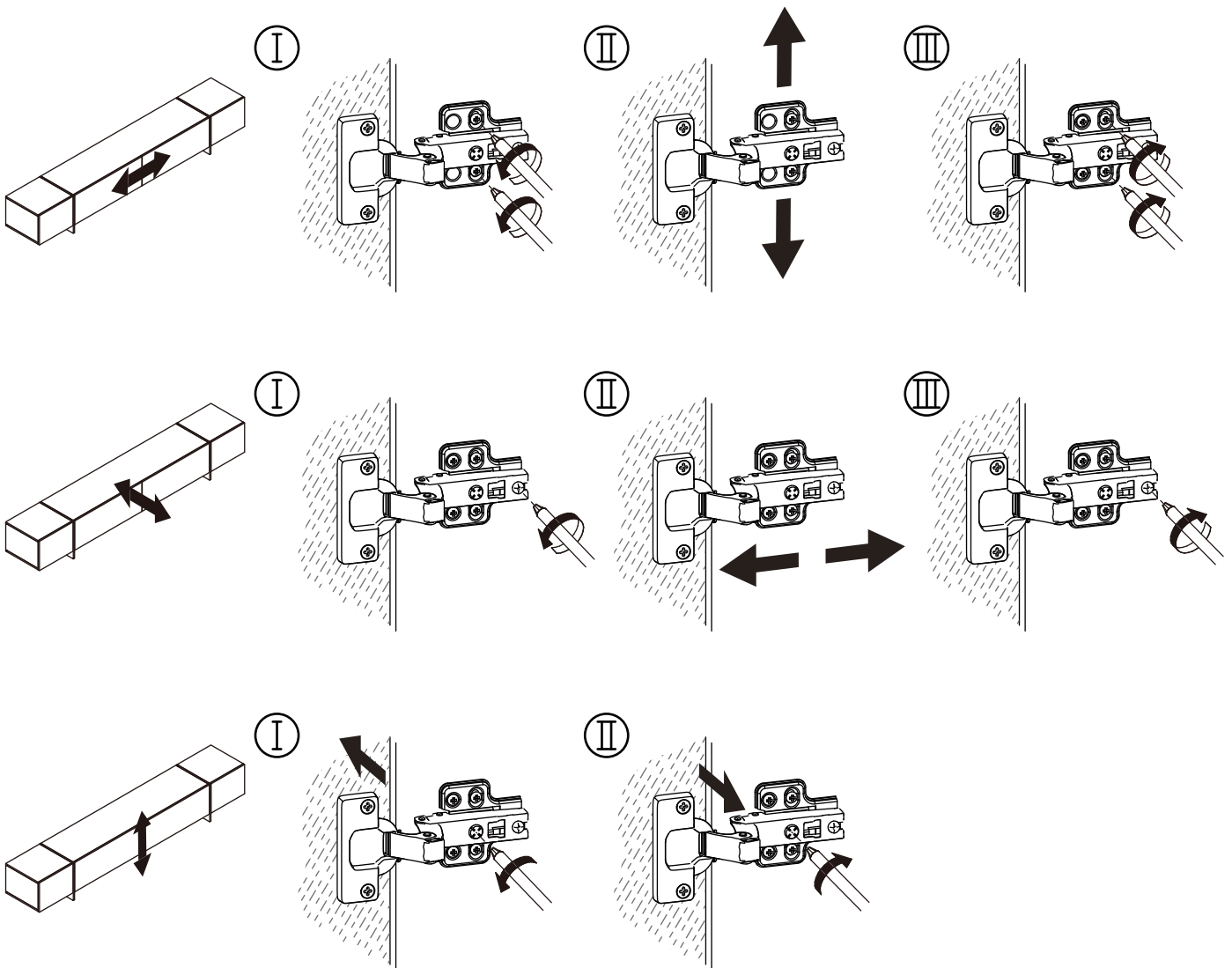

WARRANTY

WARRANTY CLAIMS

- There is a 30-day warranty for broken furniture or any other problems that do not work properly. The warranty will start from the date of purchase which must be verified by proof of purchase.
- Before making a claim, we may be able to answer your query, simply call us. Please leave your purchase order number, along with some details of the problem, if you want a replacement part. We will arrange within 48 hours. If there is out of stock, we will reply with a shipping date.
- The product must be used in accordance with the instructions provided. For health reasons.
- For other reasons, if the furniture needs to be returned, it must be cleaned and dried and operated within 30 days of receipt.

Type of Warranty Claim

- Failure to follow the furniture instructions will invalidate the warranty. Attention please.
- Does not include damage during installation, but includes damage during transportation.

Scope of responsibility

- Shall not bear any responsibility for misuse or user damage and / or loss of parts during the installation of furniture.
- After using, the damage and scratches of the furniture are not covered by the warranty.

The Warranty Relates to All Bought in The Us and Covers The Following Areas

- Sheet parts: 1 month from the date of purchase.
- Electrical parts: 1 month from the date of purchase.

GARANTIE

RÉCLAMATIONS DE GARANTIE

Il existe une garantie de 30 jours pour les meubles cassés ou tout autre problème qui ne fonctionne pas correctement. La garantie commencera à partir de la date d'achat qui doit être vérifiée par une preuve d'achat.

Avant de faire une réclamation, nous pourrions peut-être répondre à votre demande, il vous suffit de nous appeler. Veuillez laisser votre numéro de bon de commande, ainsi que quelques détails sur le problème, si vous voulez une pièce de rechange. Nous organiserons dans les 48 heures. En cas de rupture de stock, nous vous répondrons avec une date d'expédition.

Le produit doit être utilisé conformément aux instructions fournies. Pour des raisons de santé.

Pour d'autres raisons, si les meubles doivent être retournés, ils doivent être nettoyés et séchés et utilisés dans les 30 jours suivant leur réception.

Type de demande de garantie

Le non-respect des instructions du meuble annulera la garantie. Attention, s'il vous plaît.

N'inclut pas les dommages pendant l'installation, mais inclut les dommages pendant le transport.

Portée de la responsabilité

N'assume aucune responsabilité en cas de mauvaise utilisation ou de dommages causés par l'utilisateur et / ou de perte de pièces lors de l'installation du meuble.

Après utilisation, les dommages et rayures du meuble ne sont pas couverts par la garantie.

La garantie s'applique à tous les produits achetés aux États-Unis, dans tous les pays d'Europe et couvre les domaines suivants:

Pièces en tôle: 1 mois à compter de la date d'achat.

Pièces électriques: 1 mois à compter de la date d'achat..

RETURNS

CHANGED YOUR MIND AND NEED TO RETURN YOU ITEM?

PLEASE FOLLOW THE BELOW INSTRUCTIONS:

- If you have purchased and have simply changed your mind, follow the retailer's instructions for returns.

DEFECTIVE ITEMS

- If your item is defective in any way, i.e. it doesn't work but you can't identify why, in the first instance, please call us.

DAMAGED ITEMS

- If you receive an order with obvious shipping damage from the retailer, then we suggest the delivery is refused. If the delivery has been accepted and then shipping damage is found, please follow the specific instructions advised by the retailer.
In all circumstances please save all packaging material and paperwork for the order. Please be aware that if you dispose of packaging material or attempt to return the merchandise without contacting the fulfiller, you jeopardise your chances of making a claim, and you may not receive a credit for the return.

AFTER-SALES CONTACT

 adelahu@fufugaga.com

 208-820-0068

RETOUR

VOUS AVEZ CHANGE D'AVIS ET VOUS AVEZ BESOIN DE RETOURNER VOTRE ARTICLE ?

VEUILLEZ SUIVRE LES INSTRUCTIONS CI-DESSOUS:

Si vous avez acheté et que vous avez simplement changé d'avis, suivez les instructions du détaillant pour les retours.

ARTICLES DÉFECTUEUX

Si votre article est défectueux de quelque manière que ce soit, c'est-à-dire qu'il ne fonctionne pas, mais que vous ne pouvez pas identifier pourquoi, en premier lieu, veuillez nous appeler.

ARTICLES ENDOMMAGÉS

Si vous recevez une commande avec des dommages d'expédition évidents du détaillant, nous suggérons que la livraison soit refusée. Si la livraison a été acceptée et que des dommages d'expédition sont constatés, veuillez suivre les instructions spécifiques conseillées par le détaillant.

Dans tous les cas, veuillez conserver tout le matériel d'emballage et les documents pour la commande.

Veuillez noter que si vous vous débarrassez du matériel d'emballage ou tentez de retourner le

Marchandise Sans contacter le remplisseur, vous compromettez vos chances de faire une réclamation, et vous ne pouvez pas recevoir de crédit pour le retour.

