

**TOOLS REQUIRED  
OUTILS REQUIS**

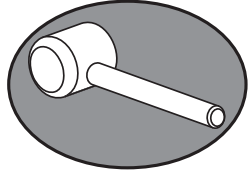

**TWO PEOPLE REQUIRED FOR ASSEMBLY  
DEUX PERSONNES REQUISES POUR L'ASSEMBLÉE**



**Move this piece of furniture gently with 2 persons.  
Déplacer ce meuble doucement avec 2 personnes.**



Read this assembly manual carefully, and verify that you have all the parts listed before you begin. Keep your assembly manual for future reference.

Lisez ce manuel de montage soigneusement. Soyez sûr que vous avez toutes les pièces d'équipement avant de commencer. Gardez ce manuel de montage pour futur référence.



**DO NOT USE POWER TOOLS TO ASSEMBLE THIS PRODUCT!  
N'UTILISEZ PAS D'OUTILS POUR ASSEMBLER CE PRODUIT!**



Do not place very hot/cold objects on top of any surface. Always use a coaster or mat. Never leave liquids on the surface: Clean immediately with a mild soap and a damp cloth. Never use scouring powder based cleanser.

Ne placez pas très chaud/froid d'objets sur une surface. Utilisez toujours un coaster ou de tapis. Ne jamais laisser liquides sur la surface Nettoyer immédiatement avec un savon doux et d'un chiffon humide.



Protect finishes by placing furniture pieces on a soft carpeted surface during assembly. Protégez la finition en plaçant les pièces du meuble sur un tapis doux pendant l'assemblage.

**During assembly, please take care not to OVERTIGHTEN any fittings it may cause damage to the product.**

**Pendant l'assemblage, veuillez prendre soin de ne pas trop serrer les raccords il peut endommager le produit.**



**DO NOT ASSUME CHILD SAFETY WITH ANY PIECE OF FURNITURE!**

Do not allow children to climb on dressers or in drawers. Do not stand or jump on beds. Improper use can cause death and or serious injury. If you are placing a TV on top of dressers use safety straps provided with your TV to prevent the risk of a toppling television. Furniture straps fastened to a wall can also be used to help ensure safety.

Damaged parts or furniture put together incorrectly can lead to serious injuries. Make sure to follow instructions correctly.



**N'assumez pas la sécurité des enfants avec n'importe quel meuble ou pièce.**







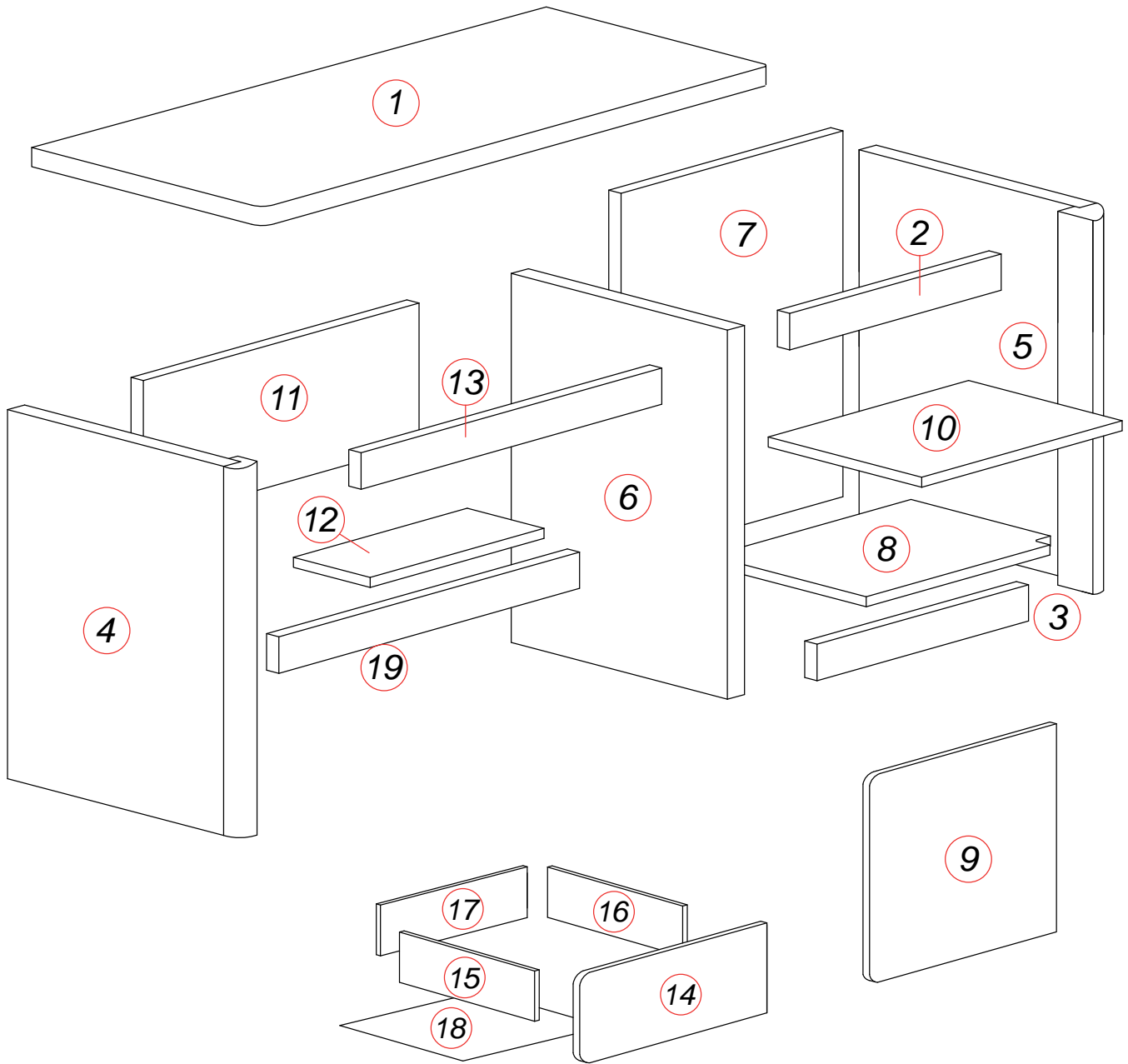

Ne permettez pas aux enfants de grimper sur les meubles ou les tiroirs. Ne pas se tenir debout ou sauter sur le lit.

L'utilisation inexacte peut causer des blessures sévères ou fatales. Si vous placez votre téléviseur au dessus du meuble assurez-vous d'utiliser les lanières de sécurité (inclus avec votre téléviseur) pour prévenir le risque de basculer le téléviseur. Les lanières de sécurité pour meuble fixées au mur peuvent aider à assurer la sécurité.



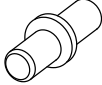

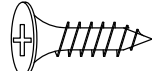
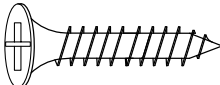
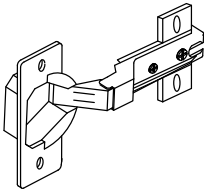
Des pièces endommagées ou un meuble assemblé incorrectement peut mener à des blessures. Assurez-vous de bien suivre les instructions.

# Part List / Liste des pièces

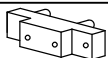

<b>NO</b>	<b>DESCRIPTION</b>		<b>QTY</b>
<b>A</b>	<b>A1</b>	<b>MINIFIX 16MM</b>	 <b>24</b>
	<b>A2</b>	<b>MINICAM 16MM</b>	 <b>24</b>
<b>B</b>	<b>WOOD DOWEL 8X 30</b>		 <b>34</b>
<b>C</b>	<b>ALLEN KEY</b>		 <b>1</b>
<b>D</b>	<b>NAIL LEG 5/8</b>		 <b>6</b>
<b>E</b>	<b>SHELF SUPPORT</b>		 <b>4</b>
<b>F</b>	<b>PLASTIC STOPPER 25MM</b>		 <b>1</b>
<b>G</b>	<b>CSK M4 X 38MM</b>		 <b>4</b>
<b>H</b>	<b>CSK M3.5 X 16MM</b>		 <b>10</b>
<b>I</b>	<b>CSK M3.5 X 12MM</b>		 <b>4</b>
<b>J</b>	<b>CSK M3 X 12MM</b>		 <b>6</b>
<b>K</b>	<b>CSK M3.5 X 25MM</b>		 <b>1</b>
<b>L</b>	<b>HINGES 7/8 (SJ 09V-295)</b>		 <b>2</b>
<b>M</b>	<b>M1</b>		<b>1 SET</b>
	<b>M2</b>		
<b>DRAWER SLIDE L&amp;R= 350MM (1MM)</b>			

# 1

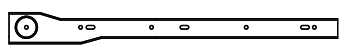
F		x1	H		x2	I		x1
K		x1	M2					

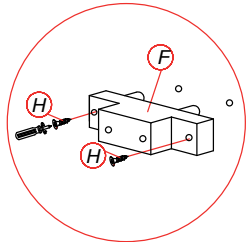

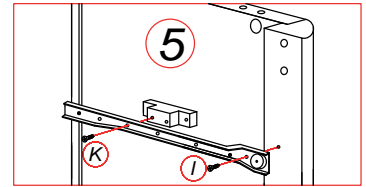
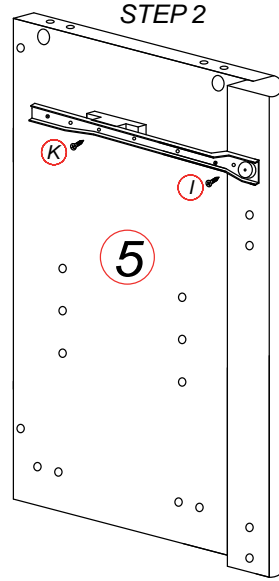
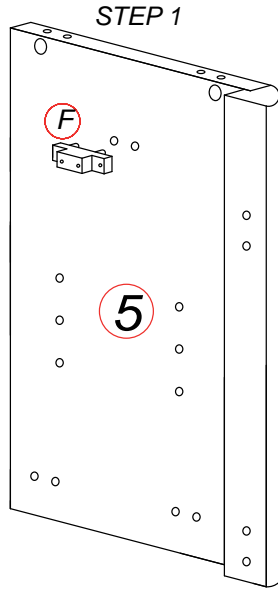

RIGHT SIDE  
PANEL NO 5



RIGHT SIDE  
PANEL NO 5

# 2

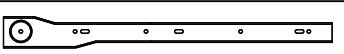
I		x1	J		x2	M2	
---	---	----	---	---	----	----	--

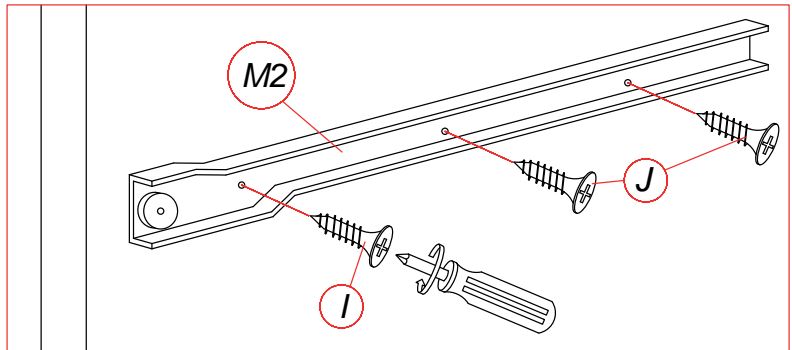
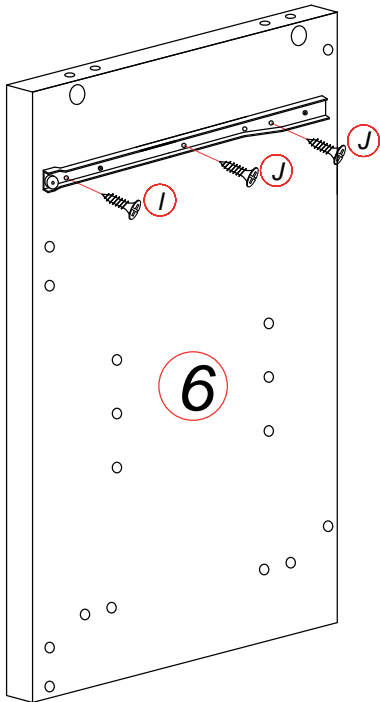

# 3

A1		x3	A2		x2	B		x6	C		x1
----	--	----	----	--	----	---	--	----	---	--	----

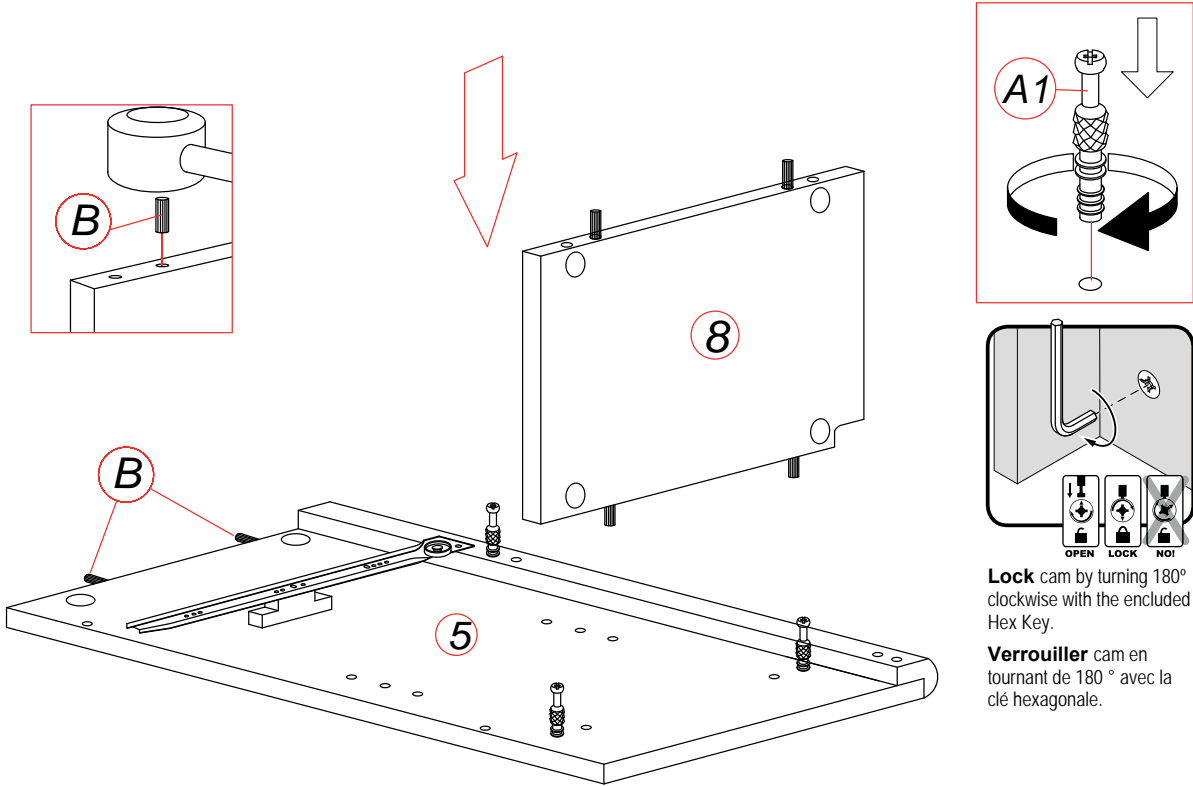

**Lock** cam by turning 180° clockwise with the included Hex Key.

**Verrouiller** cam en tournant de 180 ° avec la clé hexagonale.

# 4

A2		x1	B		x6	C		x1
----	--	----	---	--	----	---	--	----

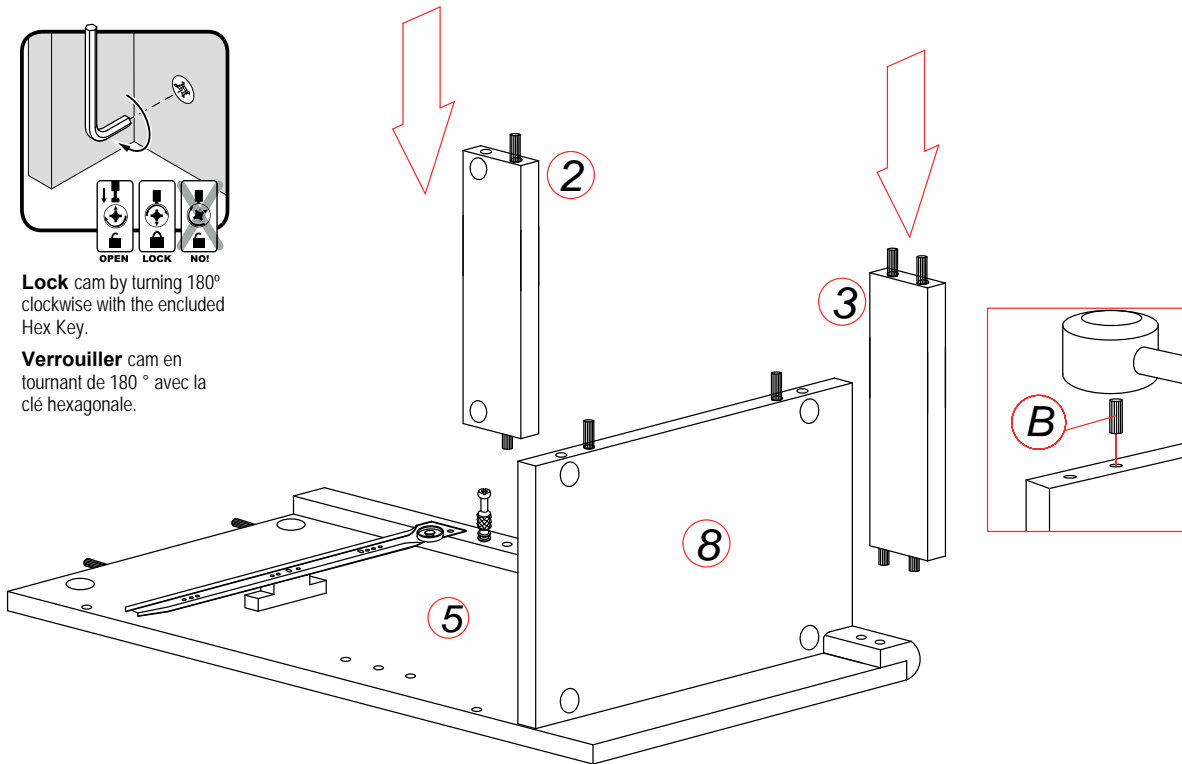

**Lock** cam by turning 180° clockwise with the included Hex Key.



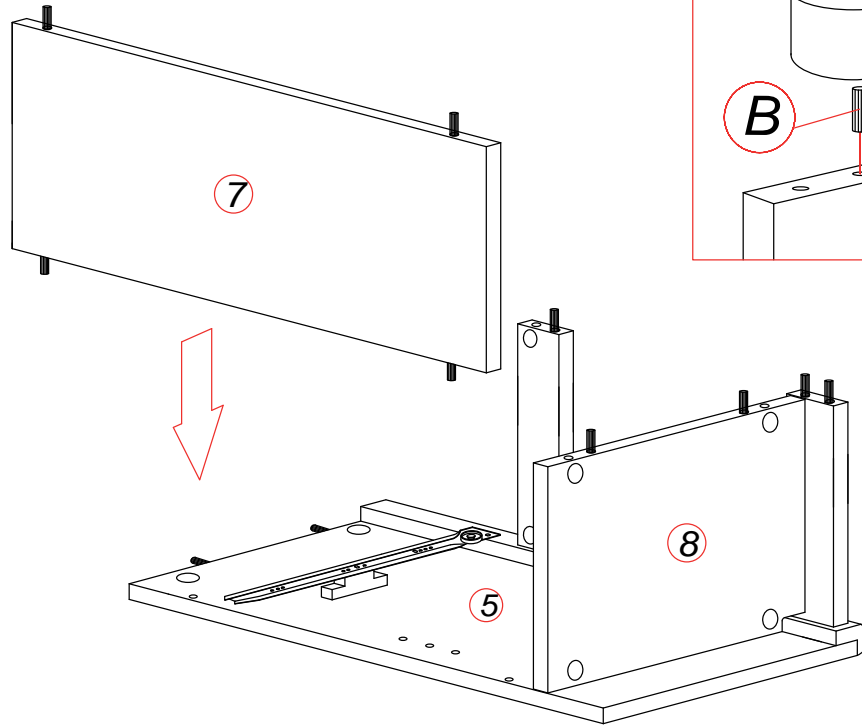

**Verrouiller** cam en tournant de 180 ° avec la clé hexagonale.

# 5

B		x4
---	--	----



# 6

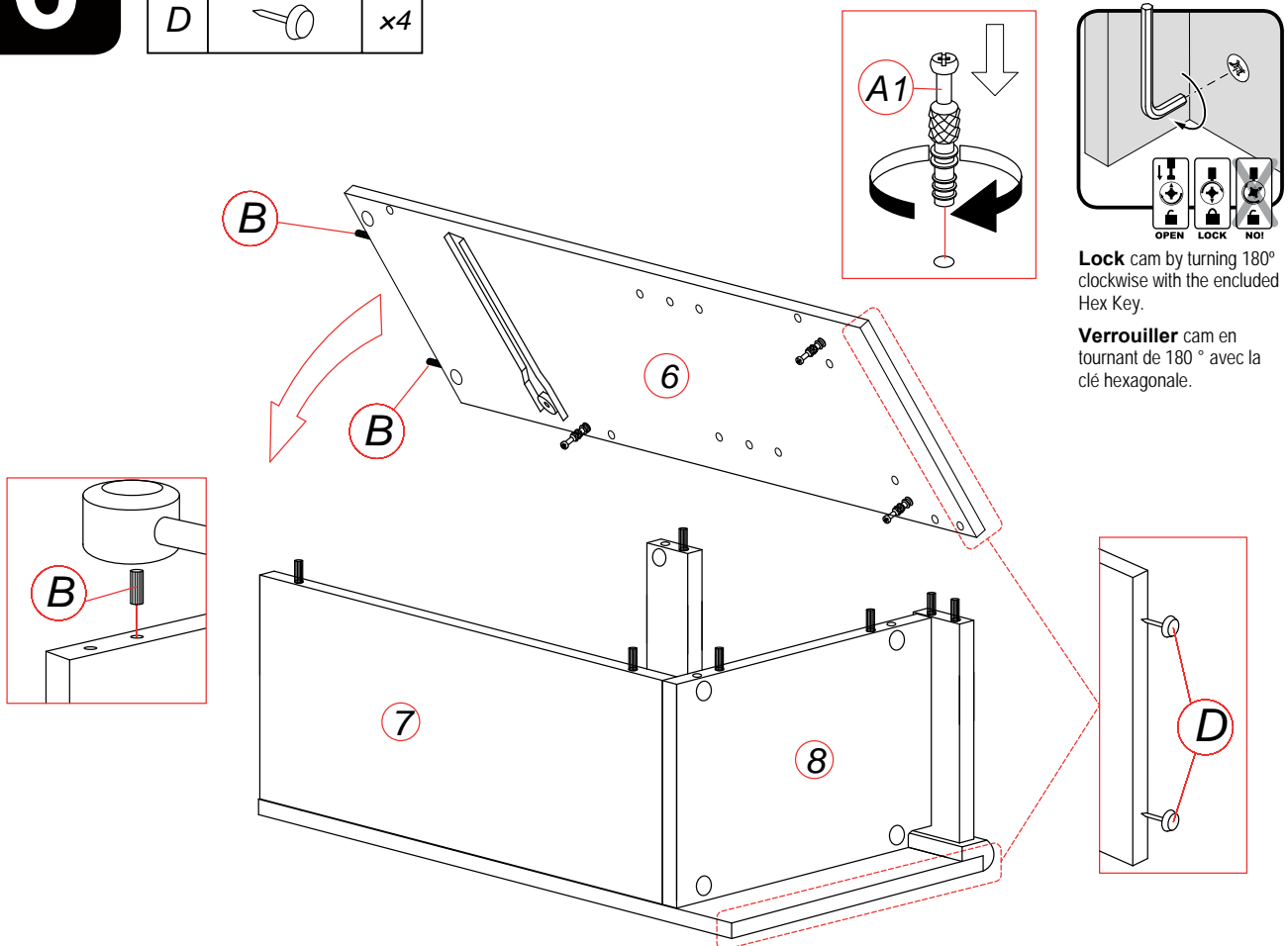

A1		x3	A2		x3	B		x2	C		x1
D		x4									



**Lock** cam by turning 180° clockwise with the included Hex Key.



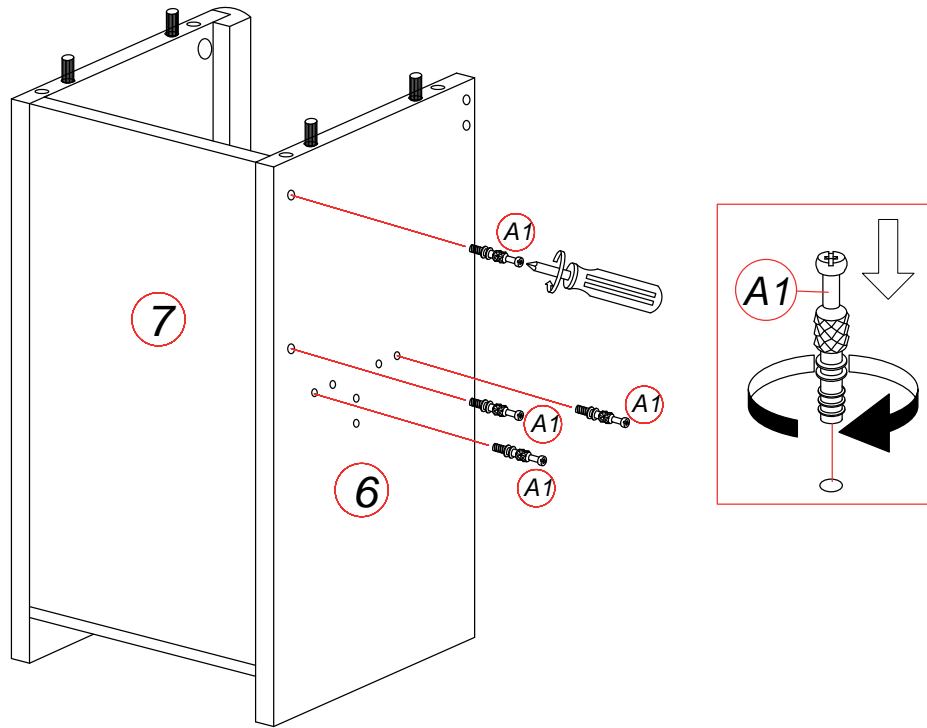

**Verrouiller** cam en tournant de 180° avec la clé hexagonale.

# 7

A1		x4	C		x1
----	--	----	---	--	----



# 8

A1		x4	A2		x4	B		x12	C		x1
D		x2									

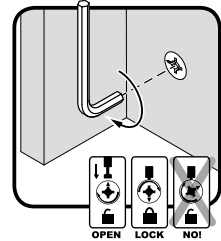
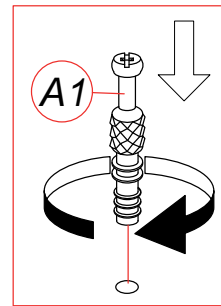
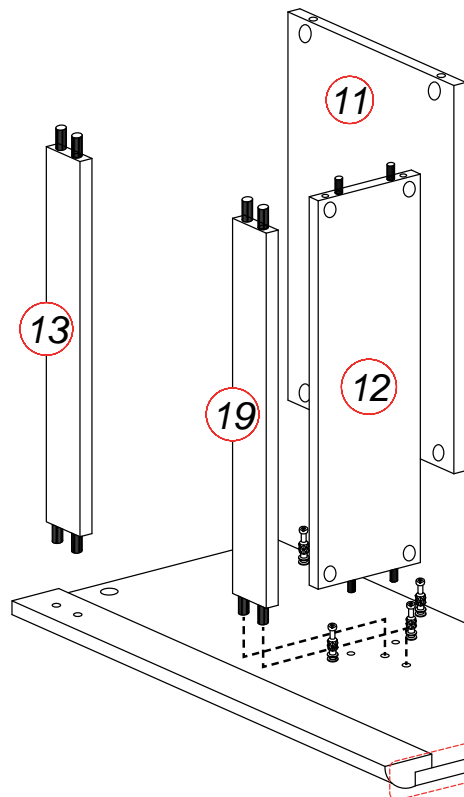
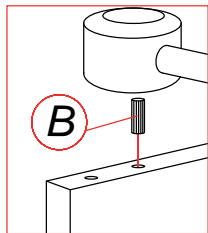

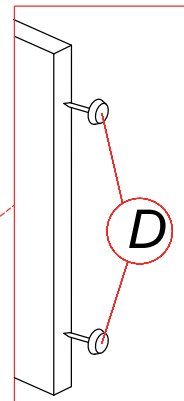

**Lock** cam by turning 180° clockwise with the included Hex Key.

**Verrouiller** cam en tournant de 180° avec la clé hexagonale.



# 9

A2		x4	B		x2	C		x1
----	--	----	---	--	----	---	---	----

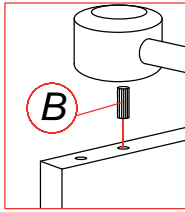

**Lock** cam by turning 180° clockwise with the included Hex Key.

**Verrouiller** cam en tournant de 180° avec la clé hexagonale.

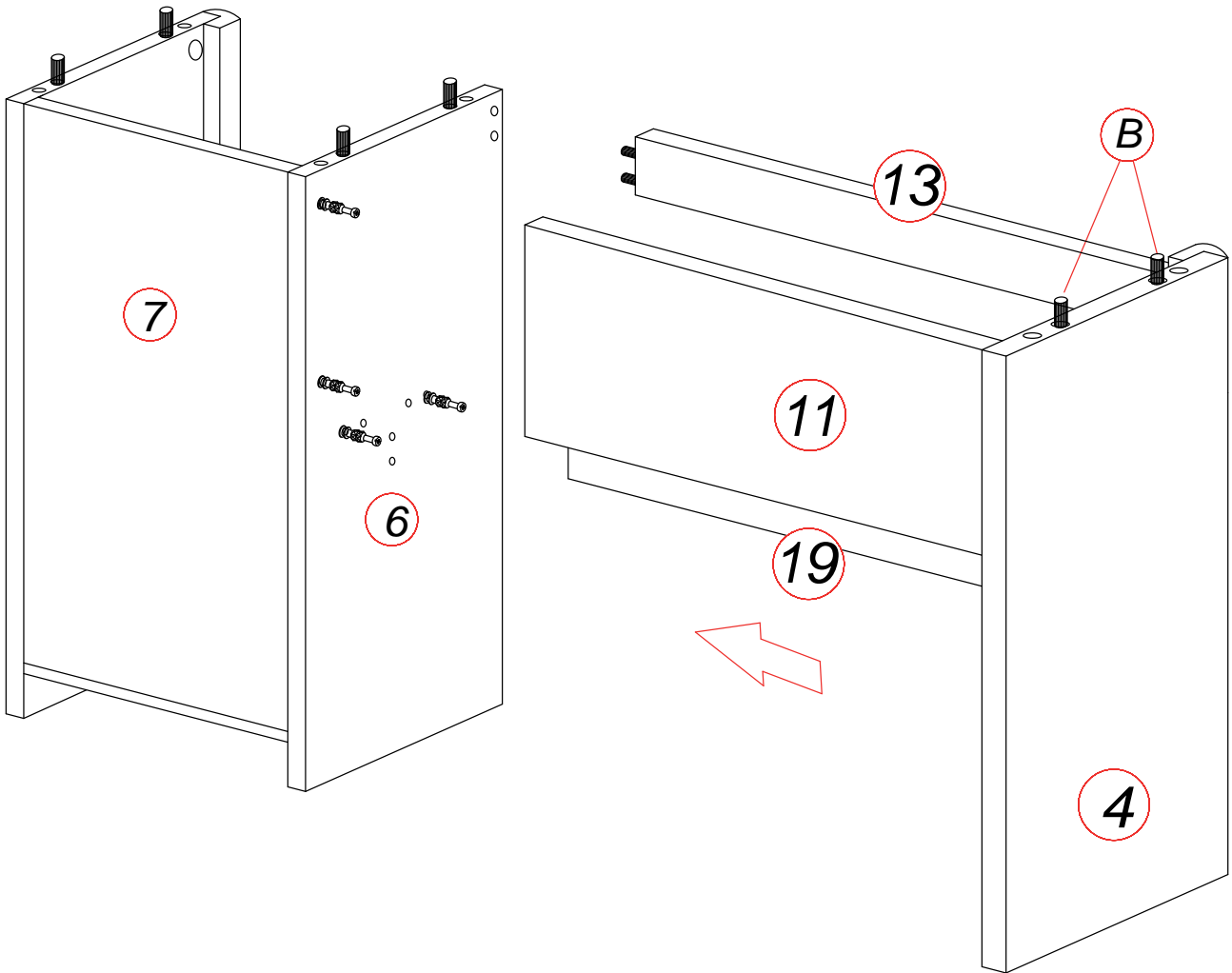
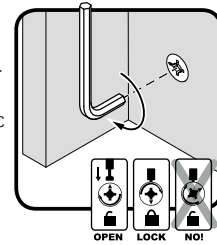

Refer to page 4 for detailed instructions for using the Cam Lock System.  
Référez-vous à la page 4 pour une description détaillée du système de came.

# 10

A1		x6	A2		x6	C		x1
----	--	----	----	--	----	---	---	----

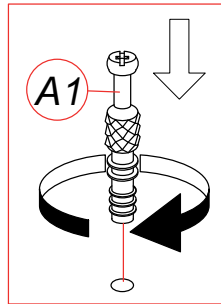

**Lock** cam by turning 180° clockwise with the included Hex Key.

**Verrouiller** cam en tournant de 180° avec la clé hexagonale.

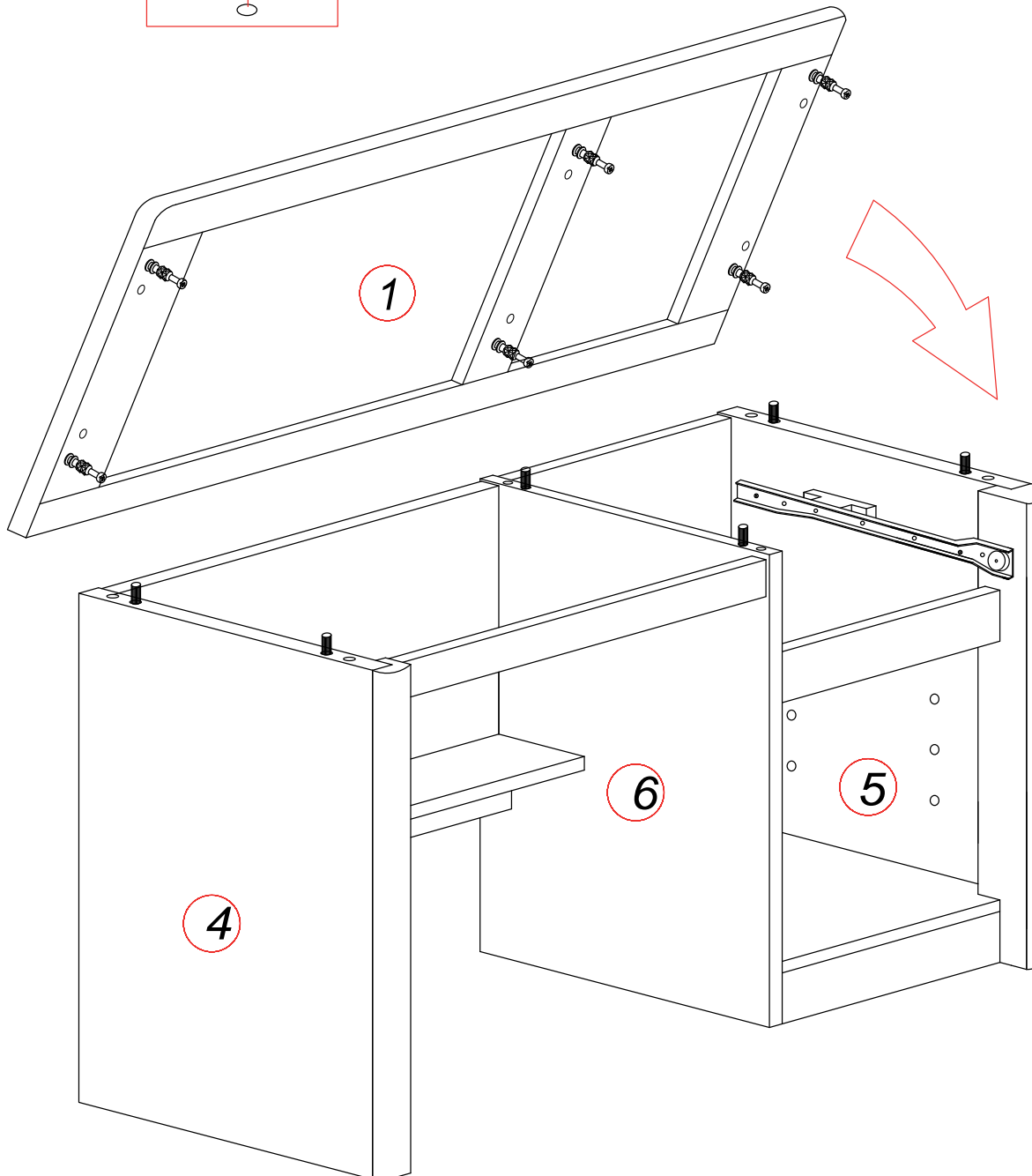
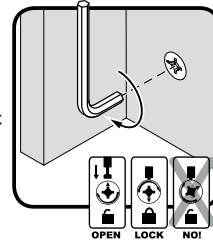

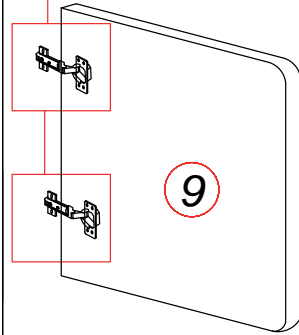
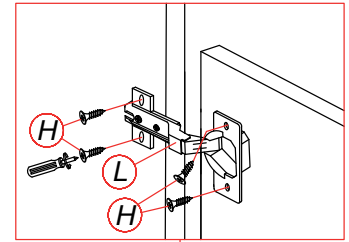
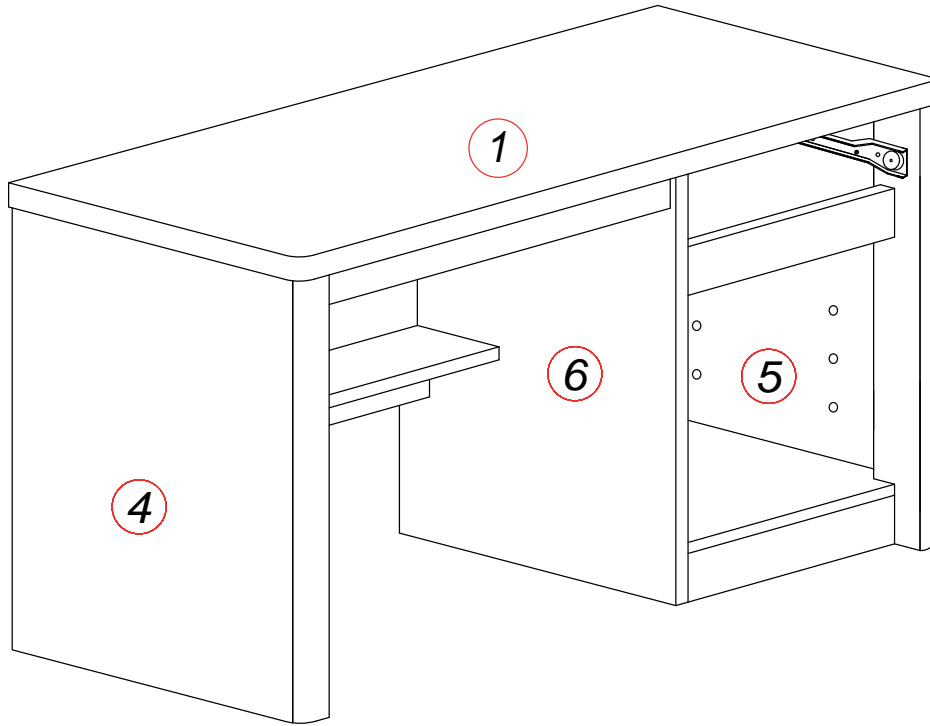
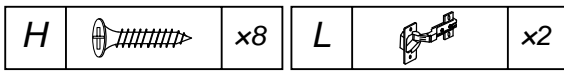

# 11

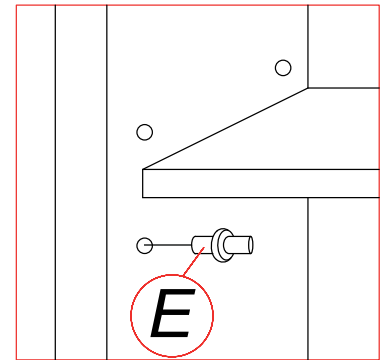
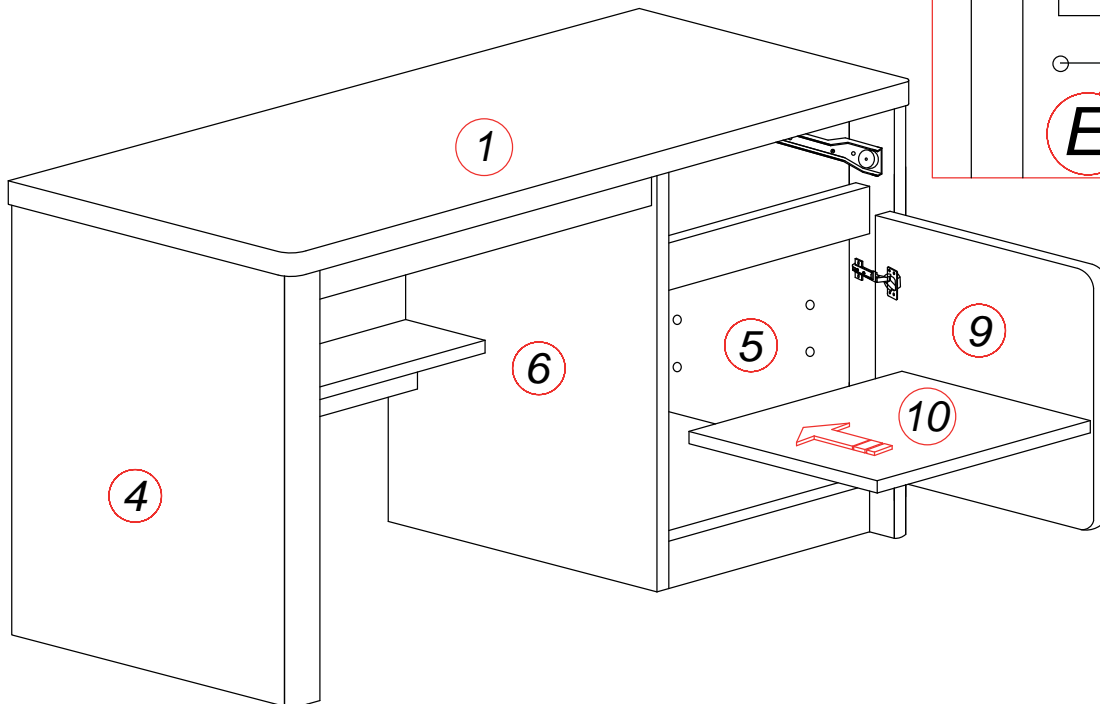
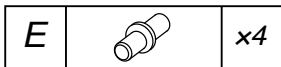

# 12



# 13

A2		x4	B		x2	G		x4
----	--	----	---	--	----	---	---	----

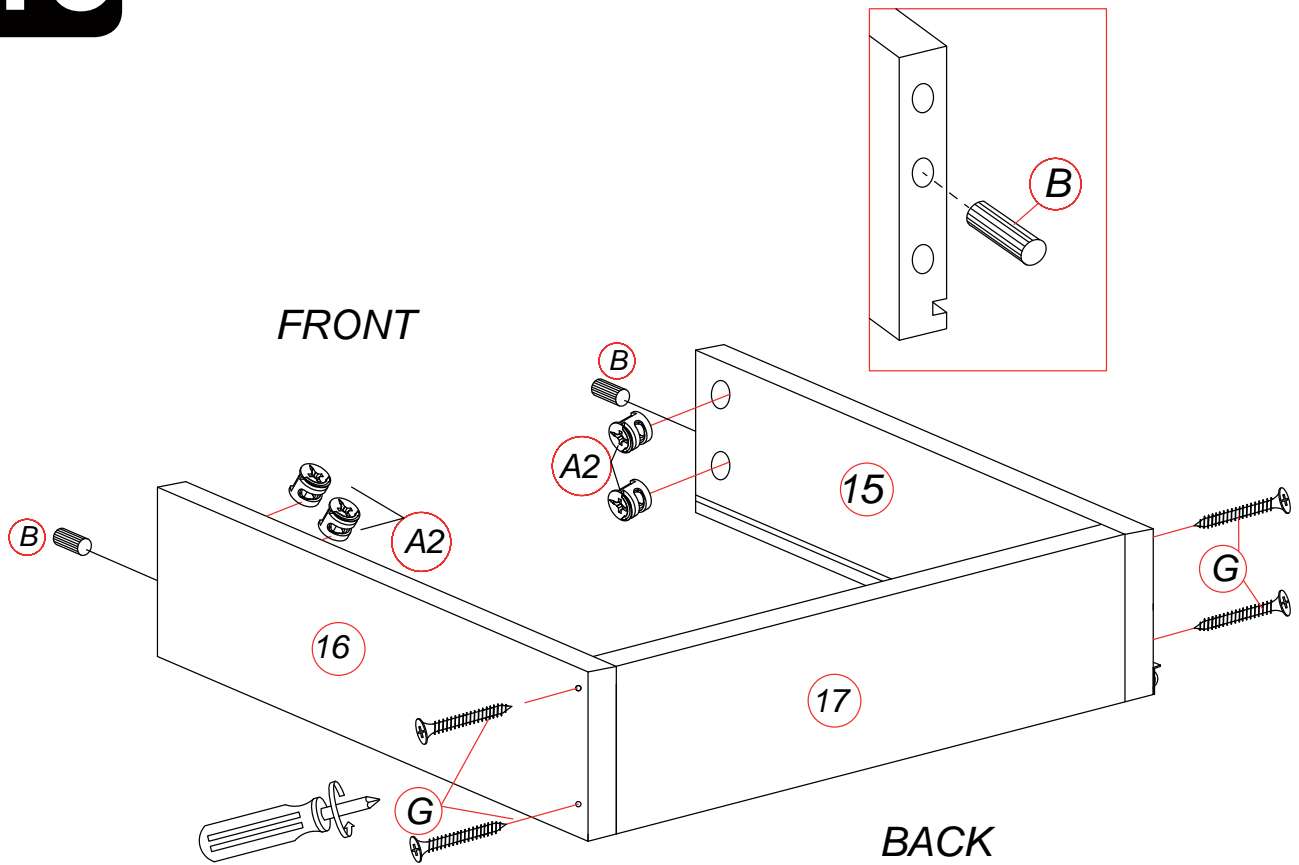

# 14

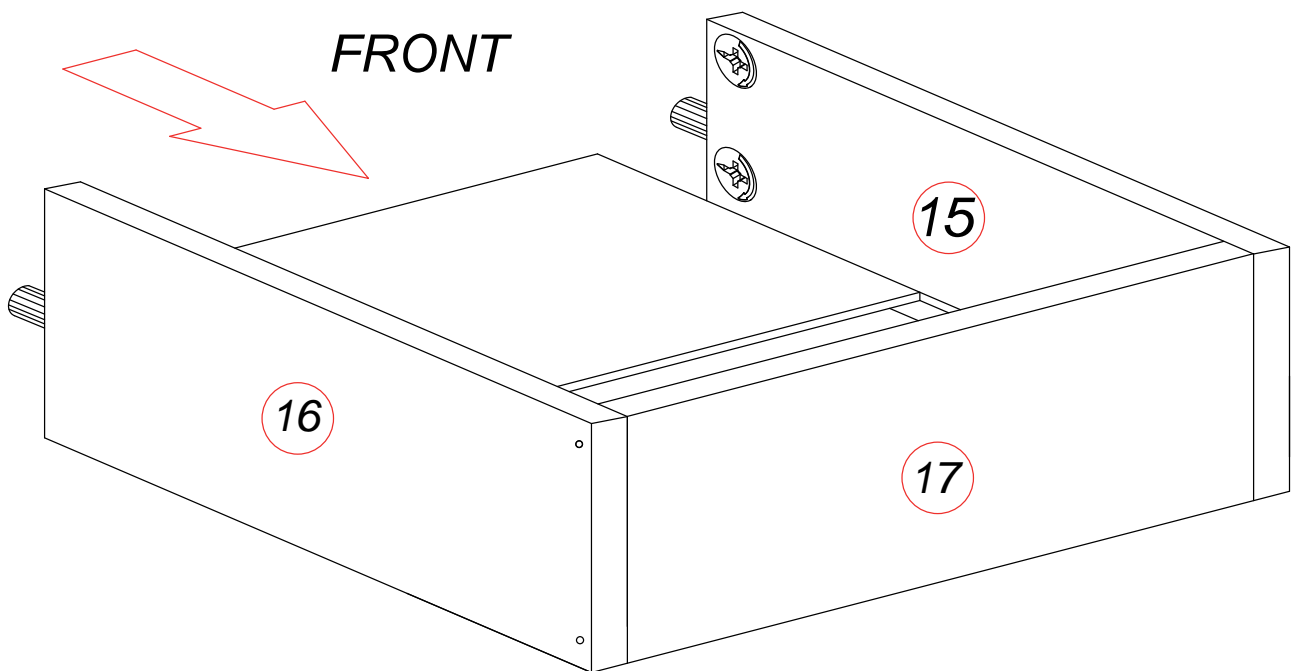

# 15

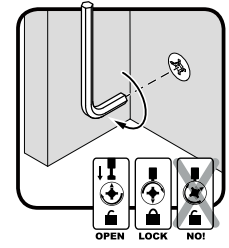
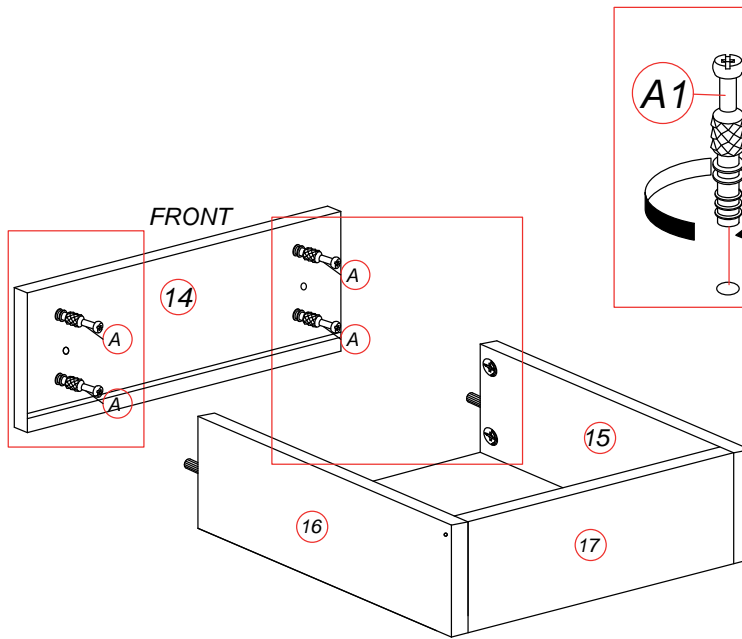
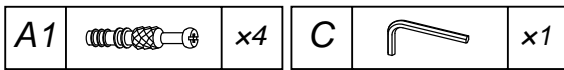

**Lock** cam by turning 180° clockwise with the included Hex Key.

**Verrouiller** cam en tournant de 180° avec la clé hexagonale.



Refer to page 4 for detailed instructions for using the Cam Lock System.  
Référez-vous à la page 4 pour une description détaillée du system de came.

# 16

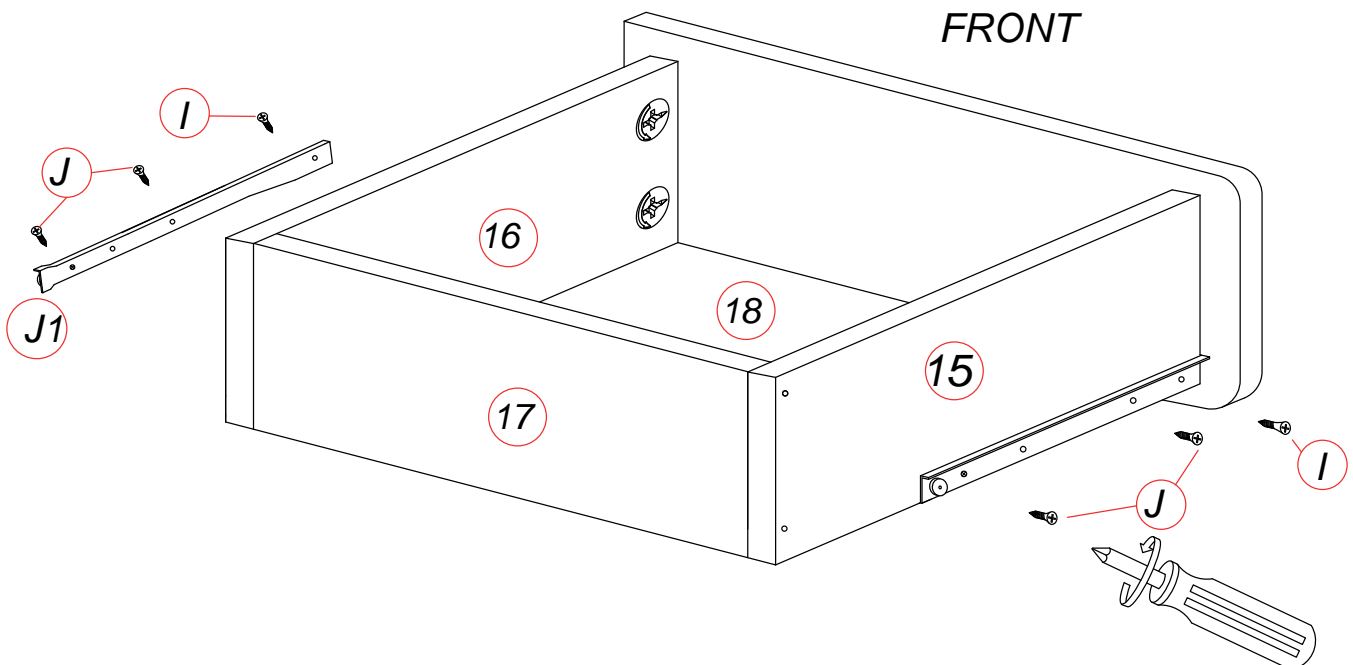
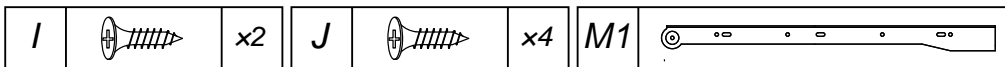

17

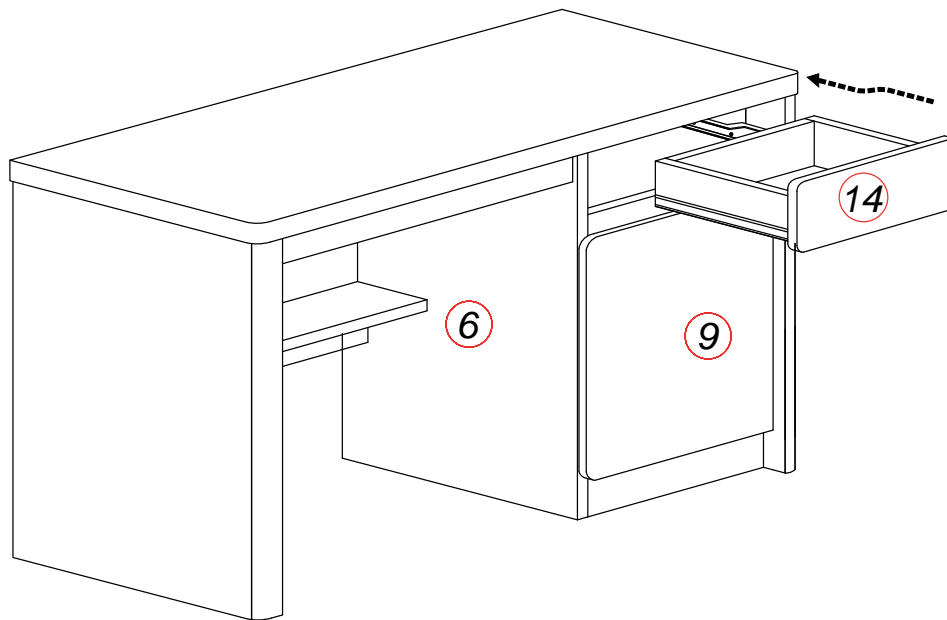

Warranty Information  
Informations sur la garantie