



Manufactured by:  
Backyard Discovery  
3305 Airport Drive, Pittsburg, KS 66762  
800-856-4445

Basepoint Business Centre: Rivermead Drive, Westlea, Swindon SN5 7EX Phone: 0800-118-2476

J.P. Coenstraat 7, The Bridge, The Hague, 2595 WP, Netherlands Phone: 08005678990

# MOUNT TRIUMPH

## SWING SET

MODEL: # 1701014



### WARNING

**Adult Assembly Required.**

The assembly manual must be retained since it contains important information  
Not suitable for children under 36 months due to small parts.

**FOR DOMESTIC USE ONLY. INTENDED FOR OUTDOOR USE.**



Please visit [www.backyarddiscovery.com](http://www.backyarddiscovery.com)

For the most up to date assembly manual, to register your product, or to order replacement parts

*Para obtener instrucciones en español, visite [www.backyarddiscovery.com](http://www.backyarddiscovery.com)*



**EASY STEP-BY-STEP  
3D INTERACTIVE INSTRUCTIONS**  
DOWNLOAD THE FREE APP



Made in China

INS-1701014-A-MOUNT TRIUMPH SWING SET-ENG 8-23-23

# Basic Setup Dimensions

Place the set on level ground, not less than 6'-7" [2 m] from any structure or obstruction such as a fence, garage, house, overhanging branches, laundry lines, or electrical wires.

## **General Information:**

Your set has been designed and engineered for children only and for residential use only. A maximum of 150 lbs. per child is recommended for play activities designed for individual use.

A maximum of 120 lbs. per child is recommended for play activities designed for multiple child use.

A maximum of 9 children is recommended for this swing set.

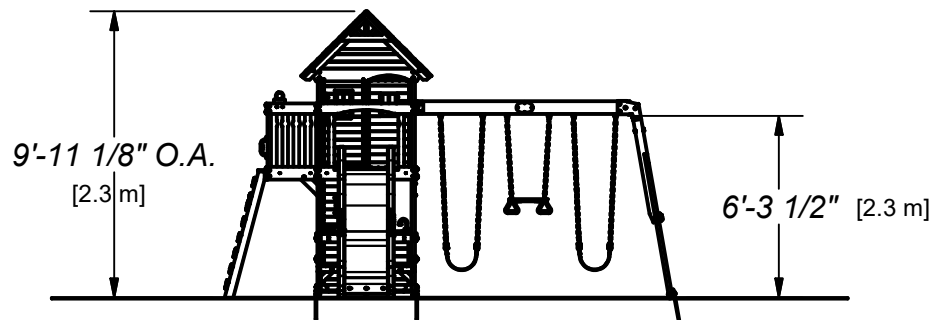
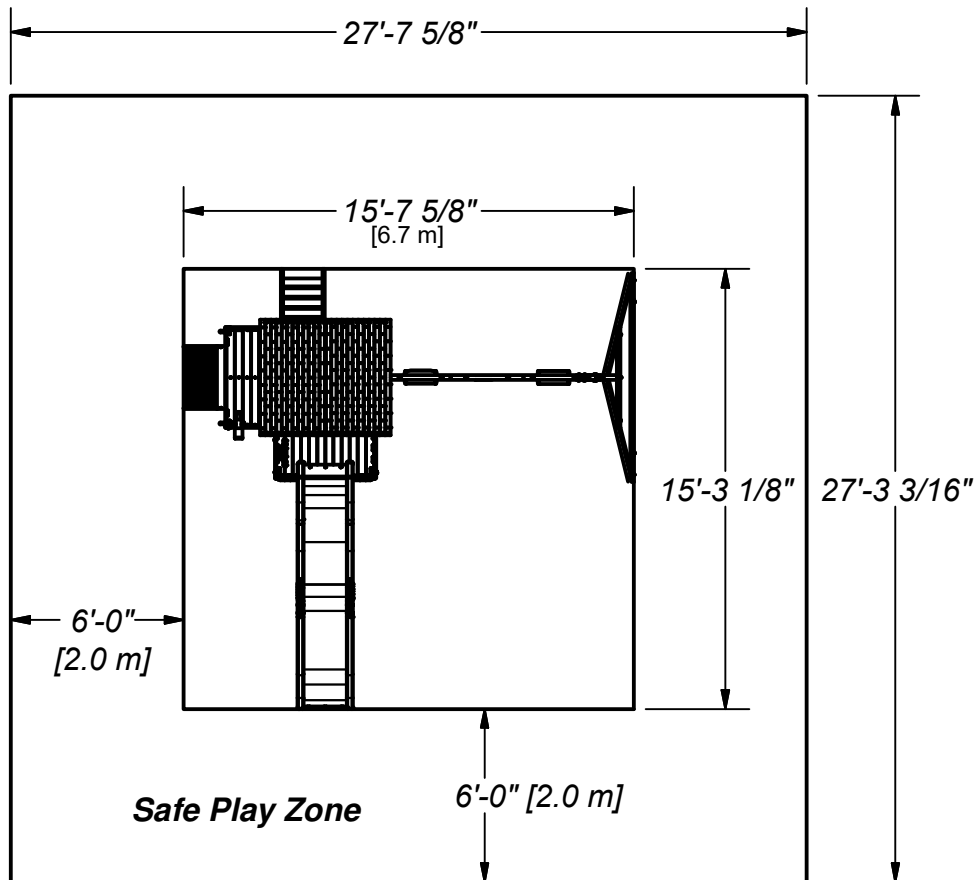

## Important Assembly Notes

Safe play height: 15'-11 1/8" [4.7 m]  
Maximum fall height: 6'-3 1/2" [1.8 m]

- 1) While assembling unit, take time before and after each phase to make sure fort is level. If fort is not level, assembly will be difficult and improper assembly may result. Extra care must be taken to ensure the fort is square.
- 2) Tighten bolts securely, tighten nuts on bolts flush to the tube or member.
- 3) Pay close attention to the ITEMS NEEDED FOR EACH PHASE. They can be a valuable aid when sorting your wood and hardware. Assembly will be made easier if items are sorted by phase.
- 4) Pay close attention to make sure you are using the correct hardware in the correct phases. Using incorrect hardware may result in improper assembly.
- 5) Whenever a T-nut is used, follow these directions. Place T-nut in pre-drilled hole. Tap in with hammer. Place bolt with washers in the opposite side. Hand tighten to make sure the bolt is in the T-nut. DO NOT over tighten.
- 6) Read the steps of each phase thoroughly. The written steps may include important information not shown in the illustrations.

# Parts Identification

## Wood Components

(NOT TO SCALE)



(1) **E1 - RIGHT REAR UPRIGHT - W2A02080**  
1 3/8"x3 3/8"x51 3/4" (36x86x1314)



(1) **E2 - LEFT REAR UPRIGHT - W4L07493**  
1 3/8"x3 3/8"x51 3/4" (36x86x1314)



(1) **E3 - LEFT FRONT UPRIGHT - W4L07494**  
1 3/8"x3 3/8"x51 3/4" (36x86x1314)



(1) **E4 - RIGHT FRONT UPRIGHT - W4L07495**  
1 3/8"x3 3/8"x51 3/4" (36x86x1314)



(1) **E5 - RIGHT FRONT BALCONY UPRIGHT - W4L07502**  
1 3/8"x3 3/8"x80 3/4" (36x86x2052)



(1) **E6 - LEFT REAR UPRIGHT - W4L07509**  
1 3/8"x3 3/8"x43 1/2" (36x86x1104)



(1) **E7 - RIGHT REAR UPRIGHT - W4L07510**  
1 3/8"x3 3/8"x43 1/2" (36x86x1104)



(1) **E8 - LEFT FRONT UPRIGHT - W4L07511**  
1 3/8"x3 3/8"x43 1/2" (36x86x1104)



(1) **E9 - RIGHT FRONT UPRIGHT - W4L07512**  
1 3/8"x3 3/8"x43 1/2" (36x86x1104)



(2) **E10 - MOUNTING BLOCK - W4L07615**  
1 3/8"x3"x4 3/4" (36x76x120)



(1) **E11 - RIGHT FRONT BALCONY UPRIGHT - W4L07673**  
1 3/8"x3 3/8"x80 3/4" (36x86x2052)

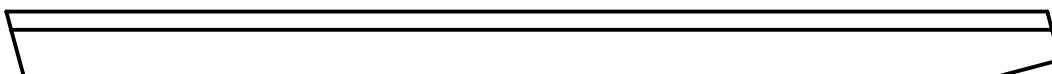

(1) **E72 - LEFT RAIL - W4L07622**  
1 3/8"x3 3/8"x54 7/8" (36x86x1395)

# Parts Identification

## Wood Components

(NOT TO SCALE)

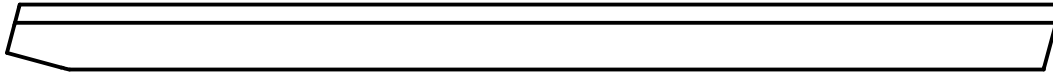

(1) **E73 - RIGHT RAIL - W4L07623**  
1 3/8"x3 3/8"x54 7/8" (36x86x1395)



(2) **E77 - ANGLE BRACE - W4L07631**  
1 3/8"x3 3/8"x74 3/8" (36x86x1890)



(1) **F1 - RIGHT BALCONY UPRIGHT - W4L07506**  
1 3/8"x2 3/8"x31 3/4" (36x60x805)



(1) **F2 - LEFT BALCONY UPRIGHT - W4L07507**  
1 3/8"x2 3/8"x31 3/4" (36x60x805)



(1) **F3 - SUPPORT BLOCK - W4L07604**  
1 3/8"x2 3/8"x5 7/8" (36x60x148)



(1) **F4 - SUPPORT BLOCK - W4L07614**  
1 3/8"x2 3/8"x5 7/8" (36x60x148)

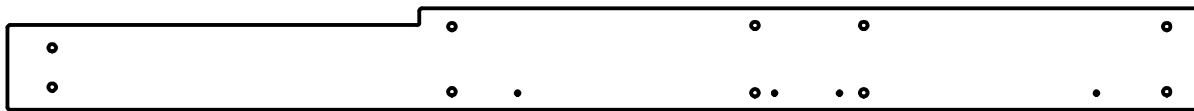

(1) **G1 - SWING BEAM MOUNT - W4L07513**  
1"x5 1/4"x62 1/8" (24x134x1577)



(1) **H1 - TABLE SUPPORT - W4L07583**  
1"x3 3/8"x22 3/8" (24x86x567)

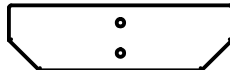

(1) **H2 - TABLE SUPPORT - W4L07584**  
1"x3 3/8"x11 5/8" (24x86x295)



(1) **H3 - TABLE SUPPORT - W4L07585**  
1"x3 3/8"x11 5/8" (24x86x295)



(4) **H4 - DECK BRACE - W4L07616**  
1"x3 3/8"x12 3/4" (24x86x325)

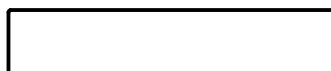

(4) **H76 - LADDER RUNG - W4L07620**  
1"x3 3/8"x17 1/4" (24x86x437)

# Parts Identification

## Wood Components

(NOT TO SCALE)

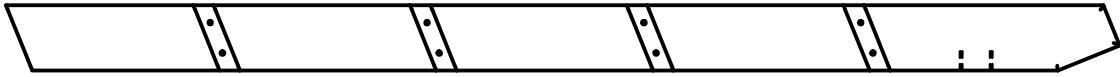

- (1) **H77 - LEFT UPRIGHT - W4L07617**  
1"x3 3/8"x58" (24x86x1474)



- (1) **H78 - RIGHT UPRIGHT - W4L07618**  
1"x3 3/8"x58" (24x86x1474)

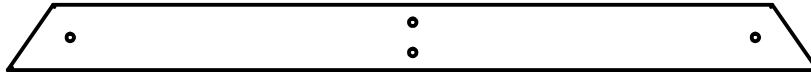

- (1) **H79 - END SUPPORT - W4L07632**  
1"x3 1/2"x42" (24x86x1072)



- (1) **H80 - GROUND BOARD - W4L07630**  
1"x3 3/8"x87 3/8" (24x86x2218)



- (1) **J1 - PORCH GROUND BOARD - W4L07504**  
1"x2 3/8"x40 1/2" (24x60x1030)



- (1) **J2 - PORCH GROUND BOARD - W4L07505**  
1"x2 3/8"x40 5/8" (24x60x1032)



- (2) **J3 - BENCH SUPPORT - W4L07586**  
1"x2 3/8"x9" (24x60x230)



- (2) **J4 - ANGLE BRACE - W4L07587**  
1"x2 3/8"x10" (24x60x254)



- (2) **J5 - SUPPORT BLOCK - W4L07588**  
1"x2 3/8"x2 7/8" (24x60x72)



- (2) **J6 - SUPPORT BLOCK - W4L07589**  
1"x2 3/8"x6 1/4" (24x60x160)



- (1) **J7 - SUPPORT BLOCK - W4L07595**  
1"x2 3/8"x3 3/8" (24x60x86)



- (1) **J8 - FLOOR JOIST - W4L07602**  
1"x2 3/8"x40 1/2" (24x60x1029)

# Parts Identification

## Wood Components

(NOT TO SCALE)



(1) **J9 - FLOOR JOIST - W4L07603**  
1"x2 3/8"x20 1/4" (24x60x513)

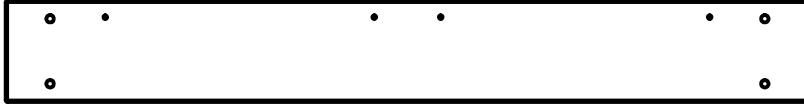

(1) **K1 - GROUND BOARD - W4L07489**  
5/8"x5 1/4"x41 7/8" (16x134x1064)

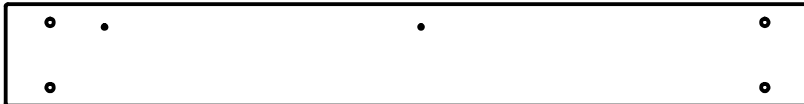

(1) **K2 - GROUND BOARD - W4L07490**  
5/8"x5 1/4"x41 7/8" (16x134x1064)

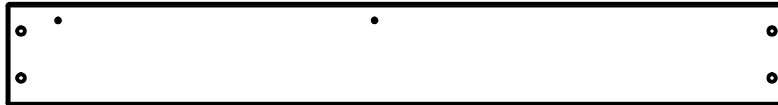

(1) **K3 - GROUND BOARD - W4L07491**  
5/8"x5 1/4"x40 1/2" (16x134x1030)

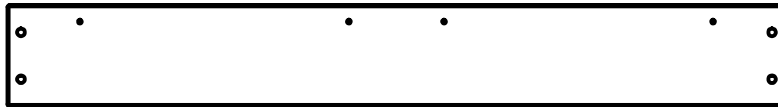

(1) **K4 - GROUND BOARD - W4L07492**  
5/8"x5 1/4"x40 1/2" (16x134x1030)



(1) **K5 - RIGHT CENTER WALL RAIL - W4L07496**  
5/8"x5 1/4"x62 3/4" (16x134x1593)

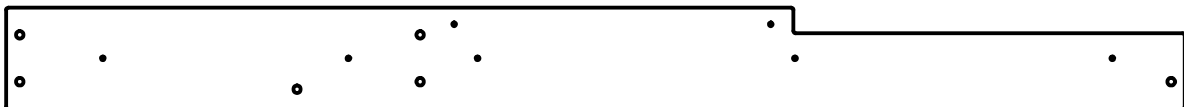

(1) **K6 - FRONT CENTER WALL RAIL - W4L07497**  
5/8"x5 1/4"x61 3/8" (16x134x1560)

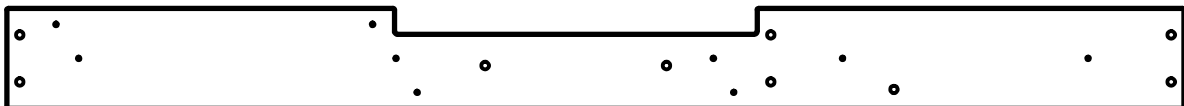

(1) **K7 - REAR CENTER WALL RAIL - W4L07498**  
5/8"x5 1/4"x61 3/8" (16x134x1560)

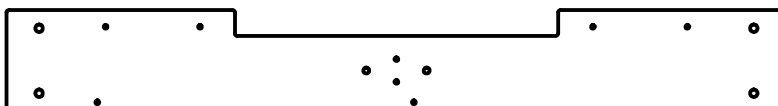

(1) **K8 - LEFT CENTER WALL RAIL - W4L07499**  
5/8"x5 1/4"x40 5/8" (16x134x1032)

# Parts Identification

## Wood Components

(NOT TO SCALE)



(1) **K9 - LEFT BALCONY WALL RAIL - W4L07500**  
5/8"x5 1/4"x20 3/4" (16x134x528)

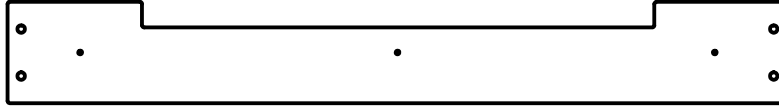

(1) **K10 - FRONT BALCONY WALL RAIL - W4L07501**  
5/8"x5 1/4"x40 5/8" (16x134x1032)

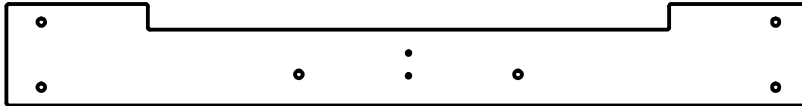

(1) **K11 - LEFT SIDE WALL BOARD - W4L07508**  
5/8"x5 1/4"x41 7/8" (16x134x1064)



(1) **K12 - ARCHED WALL RAIL - W4L07579**  
5/8"x5 1/4"x40 5/8" (16x134x1032)



(1) **K13 - ARCHED WALL RAIL - W4L07580**  
5/8"x5 1/4"x40 5/8" (16x134x1032)

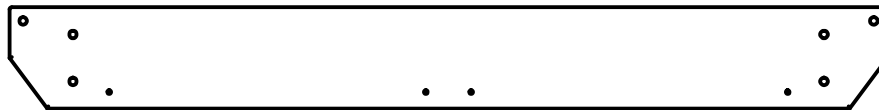

(1) **K14 - ANGLED WALL RAIL - W4L07581**  
5/8"x5 1/4"x45 3/4" (16x134x1162)

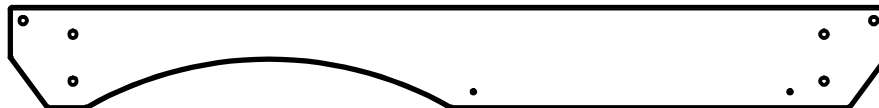

(1) **K15 - ANGLED WALL RAIL - W4L07582**  
5/8"x5 1/4"x45 3/4" (16x134x1162)

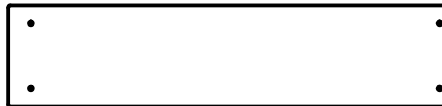

(1) **K16 - TABLE BOARD - W4L07594**  
5/8"x5 1/4"x23" (16x134x583)

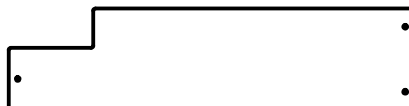

(2) **K17 - FLOOR BOARD - W4L07596**  
5/8"x5 1/4"x21 1/8" (16x134x537)

# Parts Identification

## Wood Components

(NOT TO SCALE)



- (1) **L1 - ARCHED WALL RAIL - W4L07514**  
5/8"x4 3/8"x40 5/8" (16x112x1032)



- (1) **L2 - WALL RAIL - W4L07515**  
5/8"x4 3/8"x22 7/8" (16x112x582)

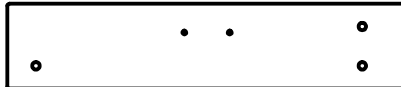

- (1) **L3 - WALL RAIL - W4L07576**  
5/8"x4 3/8"x20 7/8" (16x112x529)

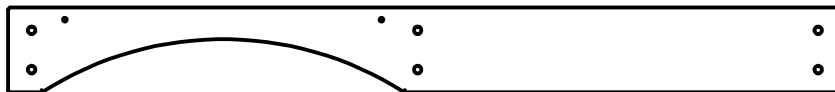

- (1) **L4 - ARCHED WALL RAIL - W4L07577**  
5/8"x4 3/8"x43 1/2" (16x112x1106)



- (1) **L5 - ARCHED WALL RAIL - W4L07578**  
5/8"x4 3/8"x40 5/8" (16x112x1032)

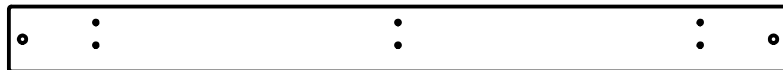

- (1) **M1 - WALL RAIL - W4L07590**  
5/8"x3 3/8"x40 1/2" (16x86x1030)

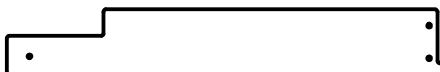

- (2) **M2 - BENCH BOARD - W4L07591**  
5/8"x3 3/8"x23" (16x86x583)



- (4) **M3 - TABLE BOARD - W4L07593**  
5/8"x3 3/8"x23" (16x86x583)



- (8) **M4 - FLOOR BOARD - W4L07597**  
5/8"x3 3/8"x21 1/8" (16x86x537)



- (1) **M5 - FLOOR BOARD - W4L07598**  
5/8"x3 3/8"x19 1/4" (16x86x488)

# Parts Identification

## Wood Components

(NOT TO SCALE)



(1) **M6 - COUNTER TOP - W4L07605**  
5/8"x3 3/8"x37 5/8" (16x86x957)



(1) **M7 - COUNTER TOP - W4L07606**  
5/8"x3 3/8"x38 5/8" (16x86x981)



(1) **M8 - FLOOR BOARD - W4L07607**  
5/8"x3 3/8"x20 1/8" (16x86x512)



(10) **M9 - FLOOR BOARD - W4L07608**  
5/8"x3 3/8"x20 1/8" (16x86x512)



(1) **M10 - FLOOR BOARD - W4L07609**  
5/8"x3 3/8"x40 5/8" (16x86x1031)

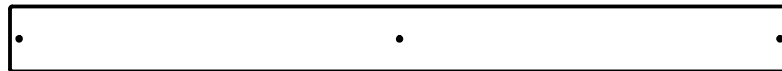

(15) **M11 - FLOOR BOARD - W4L07610**  
5/8"x3 3/8"x40 5/8" (16x86x1031)

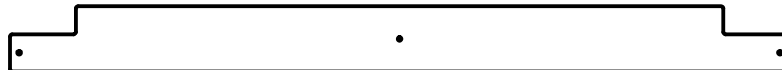

(2) **M12 - FLOOR BOARD - W4L07611**  
5/8"x3 3/8"x40 5/8" (16x86x1031)



(1) **M13 - FLOOR BOARD - W4L07671**  
5/8"x3 3/8"x20 1/8" (16x86x512)



(1) **M70 - SLIDE BED SUPPORT - W100935**  
5/8"x3 3/8"x19 7/8" (16x86x505)



(1) **M73 - REAR SUPPORT - W4L07619**  
5/8"x3 3/8"x18 1/4" (16x86x465)



(8) **M74 - ROCK WALL BOARD - W4L07624**  
5/8"x3 3/8"x25" (16x86x635)



(4) **M75 - ROCK WALL BOARD - W4L07627**  
5/8"x3 3/8"x25" (16x86x635)

# Parts Identification

## Wood Components

(NOT TO SCALE)



- (4) **M76 - ROCK WALL BOARD - W4L07626**  
5/8"x3 3/8"x25" (16x86x635)



- (1) **M102 - ATTACHMENT BOARD - W4L07628**  
5/8"x3 3/8"x26 1/4" (16x86x667)



- (1) **M108 - TOP BOARD - W4L07625**  
5/8"x3 3/8"x26 1/4" (16x86x667)



- (1) **M110 - ATTACHMENT BOARD - W4L07621**  
5/8"x3 3/8"x18 1/4" (16x86x465)



- (2) **N1 - PORCH GROUND BOARD - W4L07503**  
5/8"x2 3/8"x21 1/8" (16x60x537)



- (18) **N2 - PICKET - W4L07612**  
5/8"x2 3/8"x24 3/4" (16x60x628)



- (2) **N3 - BENCH BOARD - W4L07592**  
5/8"x2 3/8"x23" (16x60x583)

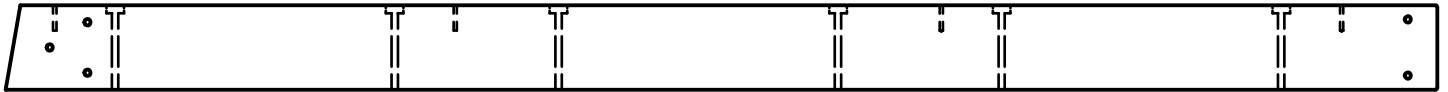

- (1) **SB74 - SWING BEAM EXTENDED - W4L07633**  
2"x5 1/4"x89 1/2" (50x134x2274)



- (3) **T1 - SUPPORT BOARD - W4L07599**  
1"x1 3/8"x37 5/8" (24x34x957)



- (1) **T2 - SUPPORT BOARD - W4L07600**  
1"x1 3/8"x37 3/4" (24x34x959)



- (2) **T3 - SUPPORT BOARD - W4L07601**  
1"x1 3/8"x18 3/4" (24x34x477)



- (1) **T4 - SUPPORT BOARD - W4L07613**  
1"x1 3/8"x37 3/4" (24x34x958)

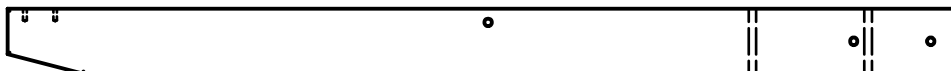

- (1) **W71 - SWING BEAM SUPPORT - W4L07629**  
2"x3 3/8"x49 5/8" (50x86x1260)

# Parts Identification

## Wood Components

(NOT TO SCALE)

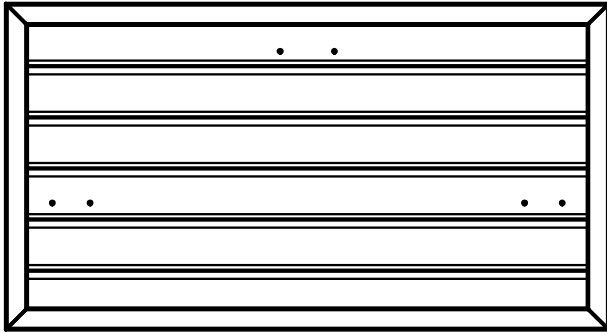

(1) WP1 - FRONT WALL PANEL - W2A02082  
1"x20 3/8"x37 3/4" (24x517x958)

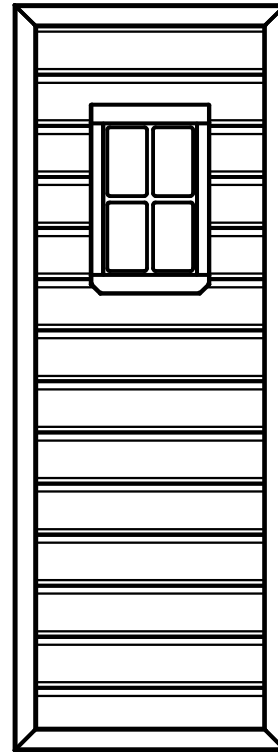

(2) WP2 - RIGHT LOWER WALL PANEL - W2A02083  
1"x16 7/8"x46 1/2" (24x430x1181)

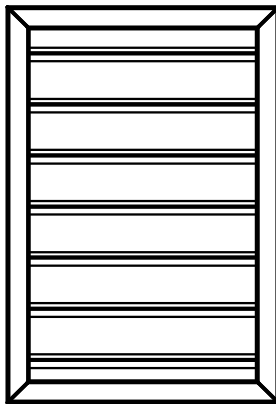

(2) WP3 - TOP RIGHT FRONT WALL PANEL - W2A02084  
1"x16 7/8"x24 5/8" (24x430x627)

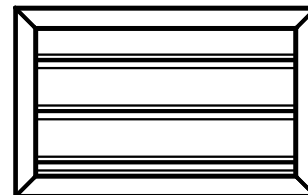

(1) WP6 - TOP REAR WALL PANEL - W2A02087  
1"x18 7/8"x11 3/4" (24x479x300)

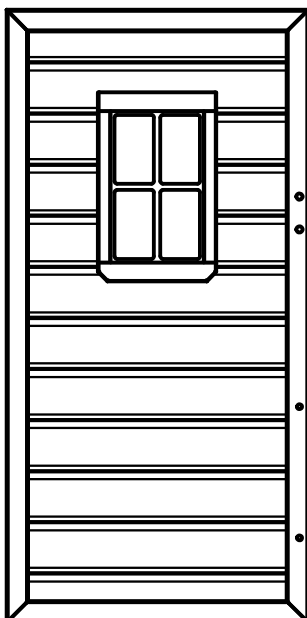

(1) WP5 - TOP LEFT REAR WALL PANEL - W2A02086  
1"x16 7/8"x46 1/2" (24x430x971)

# **Parts Identification**

## *Wood Components*

(NOT TO SCALE)

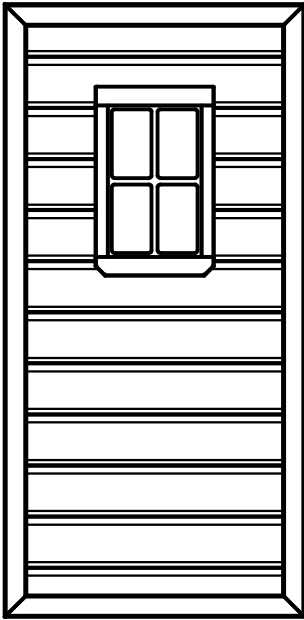

(1) WP7 - TOP FRONT WALL PANEL - W2A02088  
1"x16 7/8"x38 1/4" (24x476x971)

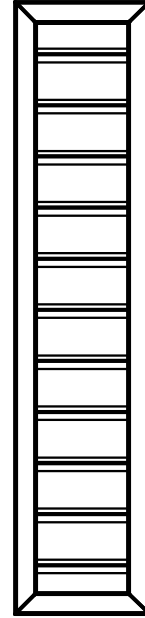

(2) WP8 - TOP LEFT WALL PANEL - W2A02089  
1"x11 3/4"x38 1/4" (24x214x971)

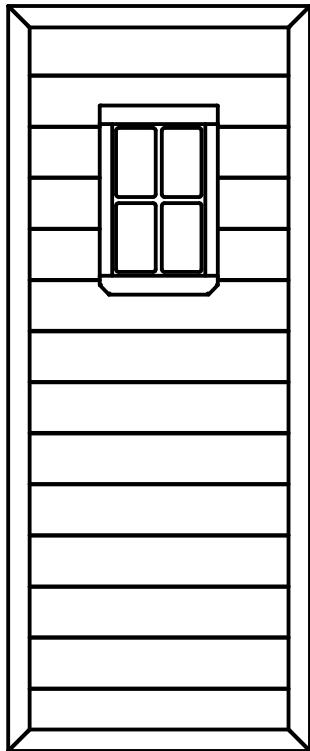

(2) WP9 - LOWER WALL PANEL - W2A02090  
1"x16 7/8"x46 1/2" (24x476x1181)

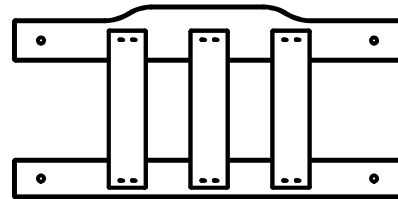

(2) WP10 - BENCH BACK ASSEMBLY - W2A02081  
1 1/8"x11 7/8"x17 5/8" (27x303x615)

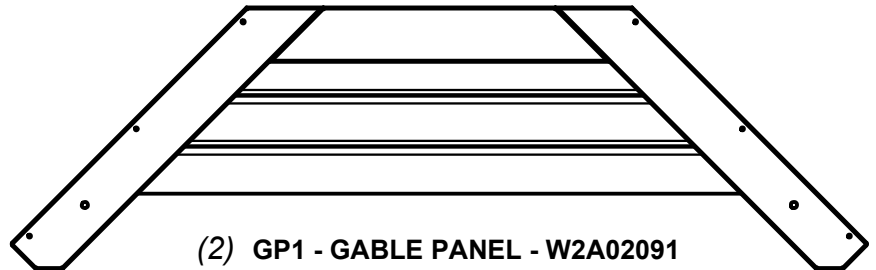

(2) GP1 - GABLE PANEL - W2A02091  
1 1/8"x53 1/2"x16 3/8" (27x1359x414)

# **Parts Identification**

## *Wood Components*

**(NOT TO SCALE)**

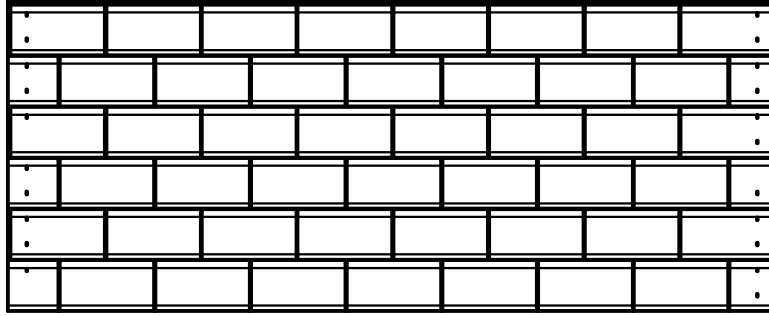

**(2) RP1 - BOTTOM ROOF PANEL - W2A02092**  
**1 3/8"x48"x19 3/8" (35x1220x491)**

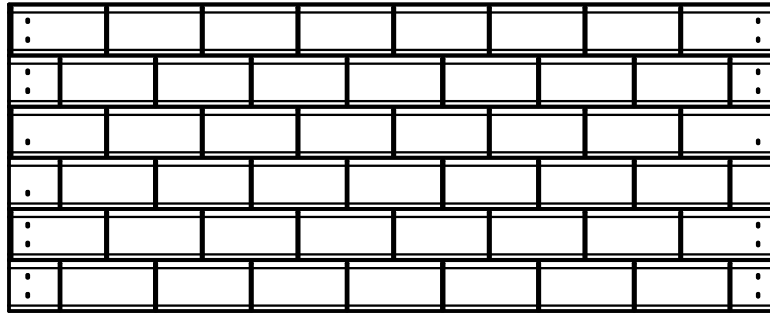

**(2) RP2 - TOP ROOF PANEL - W2A02093**  
**1 3/8"x48"x19 1/8" (35x1220x486)**

# Parts Identification

## Hardware



(4) - SCREW PFH 8x1/2 - H100124

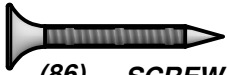

(86) - SCREW PFH 8x1-1/8" - H100088



(2) - SCREW PFH 8x1-1/4" - H100087



(245) - SCREW PFH 8x1-1/2" - H100086



(13) - SCREW PFH 8x1-3/4" - H100089



(41) - SCREW PFH 8x 2 1/2 - H100090



(4) - SCREW PFH 8x1/2 BLK - H100203



(71) - SCREW PFH 8x1-1/4 BLK - H100387



(17) - SCREW PFH 8x1-1/2 BLK - H100200



(4) - SCREW PFH 8x1 3/4 BLK - H100382



(24) - SCREW PFH 8x2 BLK - H100391



(22) - SCREW PWH 8x5/8 - H100128



(1) - BOLT WH 5/16x4 1/2 BLK - H100534



(3) - BOLT WH 5/16x2-3/4 BLK - H100195



(2) - BOLT WH 5/16x2-1/2 BLK - H100194



(7) - BOLT WH 5/16x2-1/4 BLK - H100205



(52) - BOLT WH 5/16x2 BLK - H100457



(10) - BOLT WH 5/16x1 3/4 BLK - H100378



(7) - BOLT WH 5/16x1 1/2 BLK - H100407



(9) - BOLT WH 5/16x1 1/4 BLK - H100459



(9) - BOLT WH 5/16x1/2 BLK - H100396



(28) - T-NUT 1/4 - H100072



(2) - T-NUT 1/4 BLK - H100398

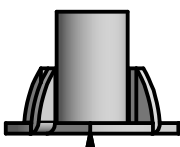

(7) - T-NUT 5/16 - H100074

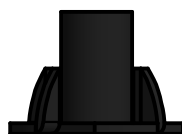

(79) - T-NUT 5/16 BLK - H100379

# Parts Identification

## Hardware

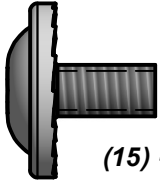

(15) - BOLT WH 5/16x1/2 - H100115

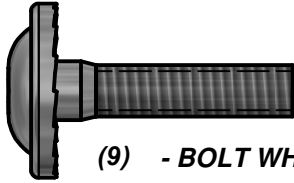

(9) - BOLT WH 5/16x1 1/4 - H100009

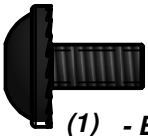

(1) - BOLT WH 1/4x1/2 BLK - H100401

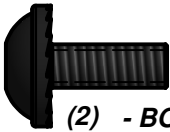

(2) - BOLT WH 1/4x5/8 BLK - H100486

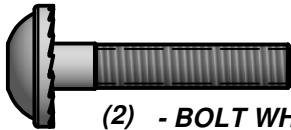

(2) - BOLT WH 1/4x1-1/4 - H100142



(43) - LAG SCREW WH 5/16x1-1/2 BLK - H100471



(9) - LAG SCREW WH 5/16x2 BLK - H100458



(2) - LAG SCREW WH 5/16x3 BLK - H100206

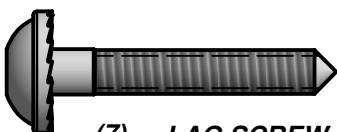

(7) - LAG SCREW WH 1/4x1-1/2 - H100145



(4) - LAG SCREW WH 1/4x1-1/2 BLK - H100403



(2) - LAG SCREW WH 1/4x2 BLK - H100487



(4) - BOLT HEX 5/16x1 - H100040



(2) - BOLT HEX 5/16x2-3/4 - H100047

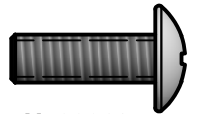

(26) - BOLT PTH 1/4x3/4 - H100063

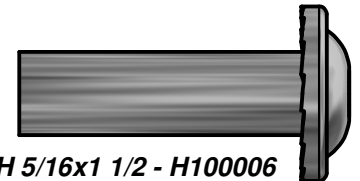

(9) - NUT BARREL WH 5/16x1 1/2 - H100006

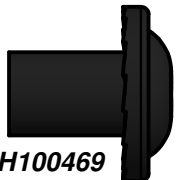

(7) - NUT BARREL WH 5/16x5/8 BLK - H100469

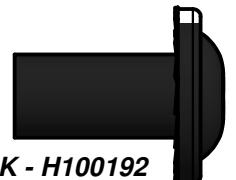

(13) - NUT BARREL WH 5/16x7/8 BLK - H100192

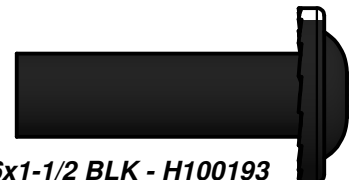

(2) - NUT BARREL WH 5/16x1-1/2 BLK - H100193



(1) - NUT BARREL WH 1/4x7/8 BLK - H100399

# Parts Identification

## Hardware



(9) - NUT LOCK 5/16 - H100110

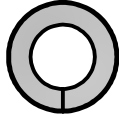

(4) - WASHER SPLIT 5/16 - H100095

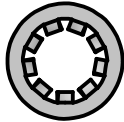

(26) - WASHER LOCK INT 8x15 - H100108

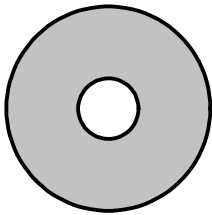

(16) - WASHER FLAT 8x27 - H100105

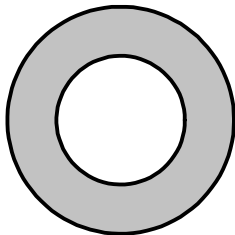

(7) - WASHER SAFETY 17x30 - H100103



(7) - WASHER LOCK EXT 6x15 BLK - H100405

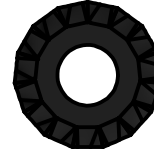

(133) - WASHER LOCK EXT 8x19 BLK - H100198

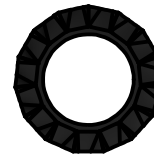

(16) - WASHER LOCK EXT 12x19 BLK - H100199

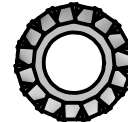

(9) - WASHER LOCK EXT 6x15 - H100138

# Parts Identification

Hardware

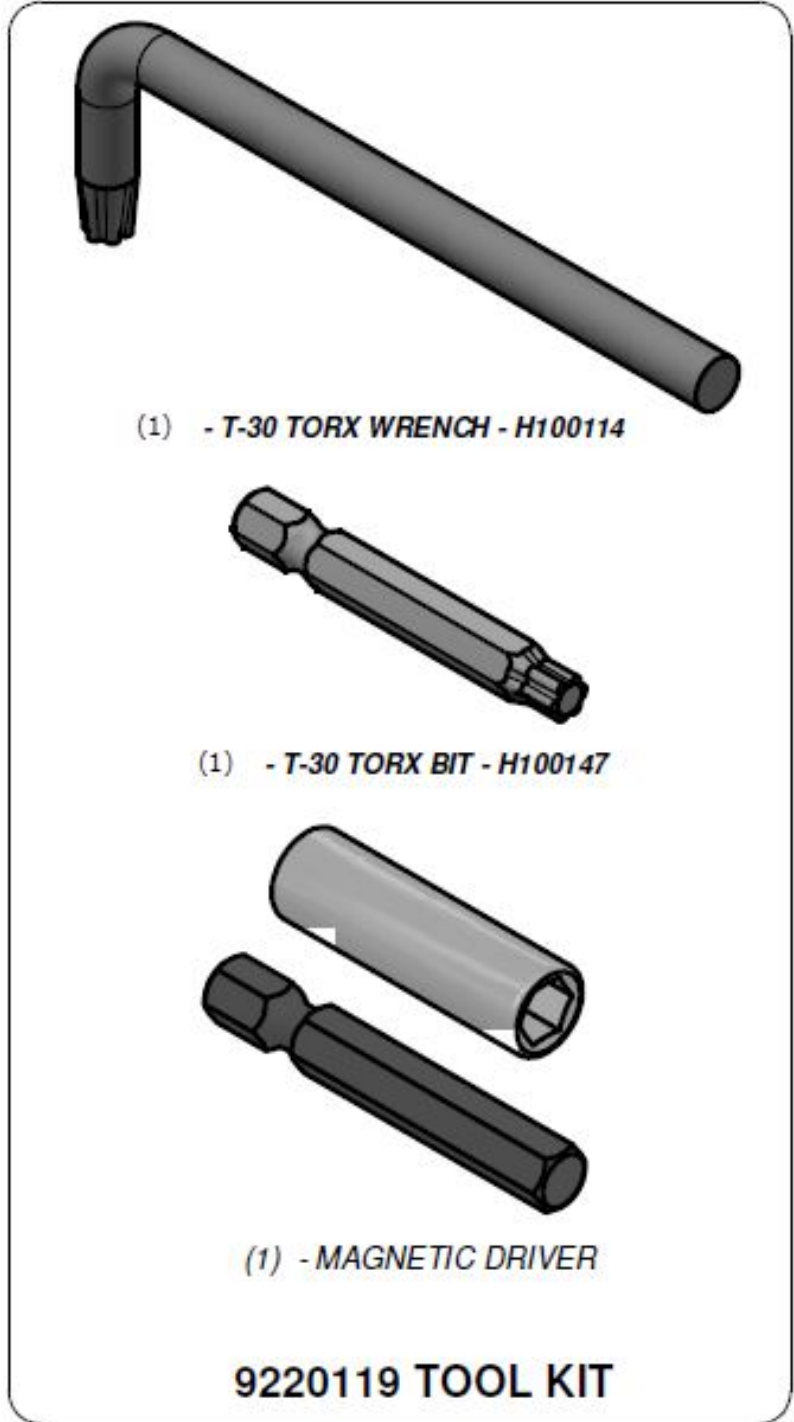
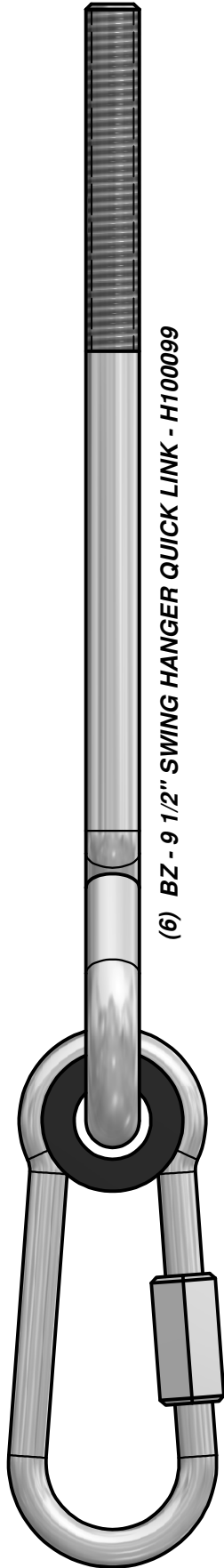

# Parts Identification

Accessories  
(NOT TO SCALE)

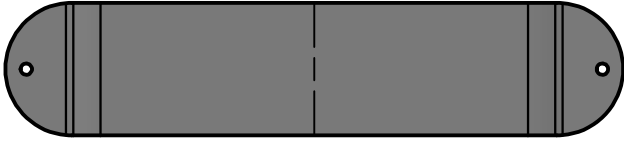

(2) DP - SWING SEAT GREEN - A100027

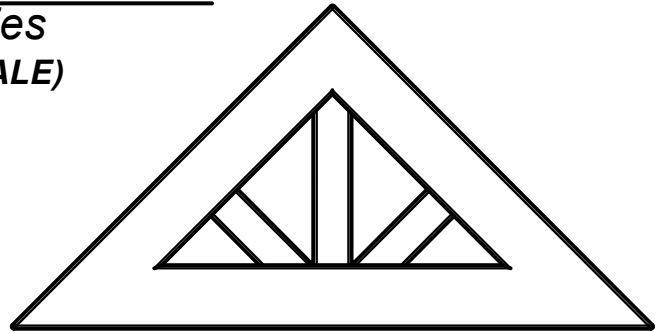

(2) SY - PLASTIC SUNBURST - A100322

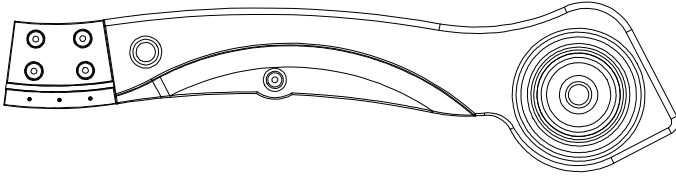

(1) DR - SLIDE RAIL 10' BOTTOM LEFT GREEN - A6P00483

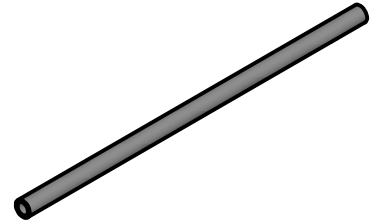

(4) DW - SLIDE SUPPORT TUBE - A6P00487

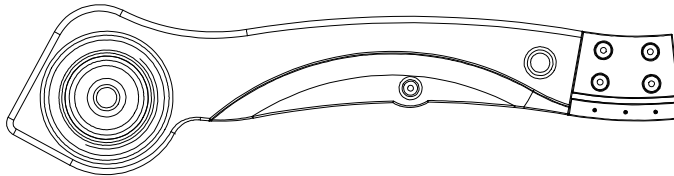

(1) DS - SLIDE RAIL 10' BOTTOM RIGHT GREEN - A6P00484

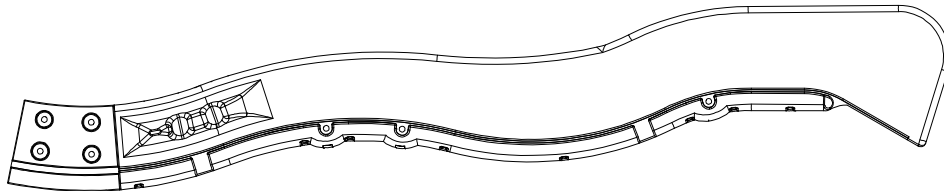

(1) DT - SLIDE RAIL 10' TOP LEFT GREEN - A6P00485

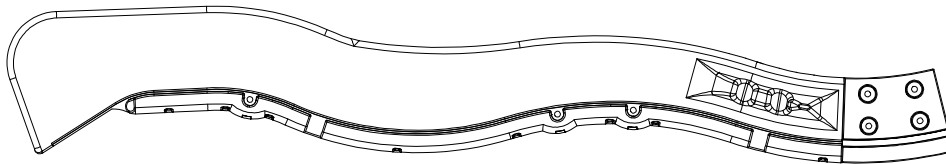

(1) TR - SLIDE RAIL 10' TOP RIGHT GREEN - A6P00486



(1) DX - SLIDE BED 10' LIGHT GREEN - A100035

# Parts Identification

## Accessories (NOT TO SCALE)

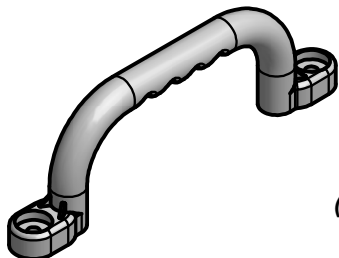

(4) EA - HAND GRIP YELLOW PLASTIC - A100043



(1) SQ - "A" REVISION TAG - A100314

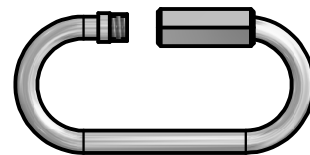

(6) FA - QUICK LINK - A100069

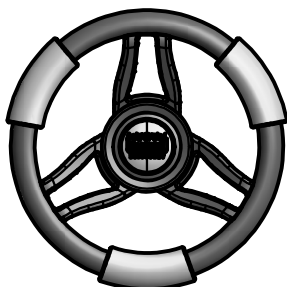

(1) LP - STEERING WHEEL - A100105

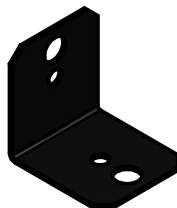

(2) - 90° L-BRACKET - BLK - A4M00555

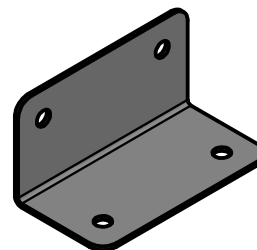

(2) GD - L BRACKET 66x66x127 - A100140

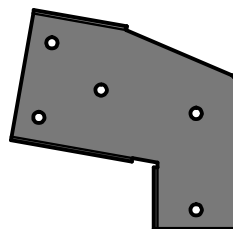

(1) TB - SWING BEAM EXTENSION BRACKET-LEFT - A100325

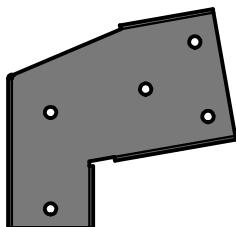

(1) TC - SWING BEAM EXTENSION BRACKET-RIGHT - A100326



(1) HC - BYD ID TAG (LARGE) WITHOUT AGES - A100242

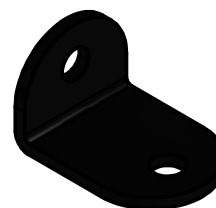

(2) - L BRACKET BLACK 32x51 - A4M00710



(6) - GROUND STAKE REBAR - A4M00527



(2) KN - CHAIN GREEN 31" - A100177



(4) EZ - CHAIN GREEN 51.25" - A100068

# Parts Identification

Accessories  
(NOT TO SCALE)

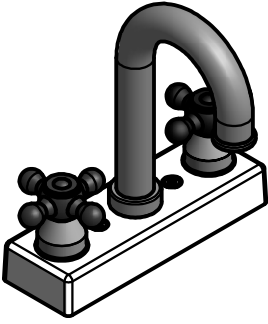

(1) - FAUCET KIT - A6P00024

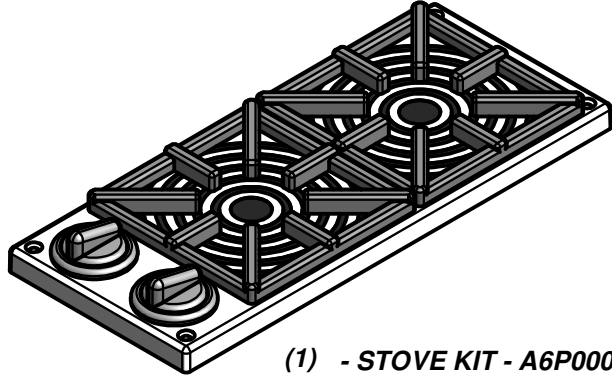

(1) - STOVE KIT - A6P00025

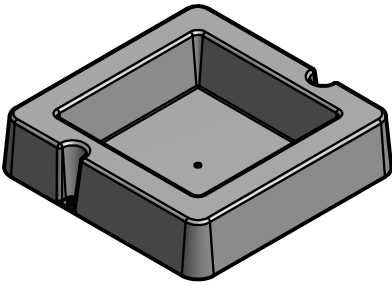

(1) - SURFACE MOUNT BASIN - A6P00032

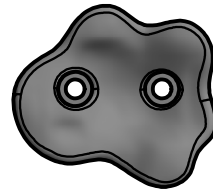

(3) - GREEN HC ROCK #1 - A6P00036

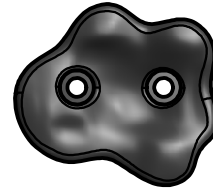

(3) - RED HC ROCK #1 - A6P00038



(1) - TRAPEZE - A6P00034

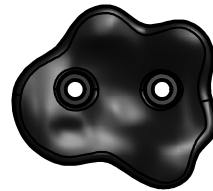

(3) - BLUE HC ROCK #2 - A6P00040

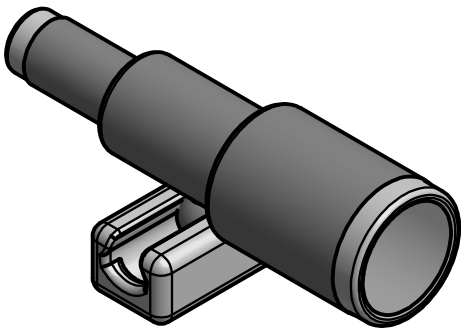

(1) LN - Telescope - A6P00096

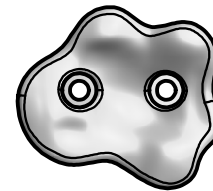

(3) - YELLOW HC ROCK #1 - A6P00042

# Parts Identification

Accessories  
(NOT TO SCALE)



APPLE



ORANGE



WATERMELON



STRAWBERRY

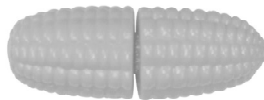

CORN



CARROT



PLASTIC KNIFE



CUTTING BOARD

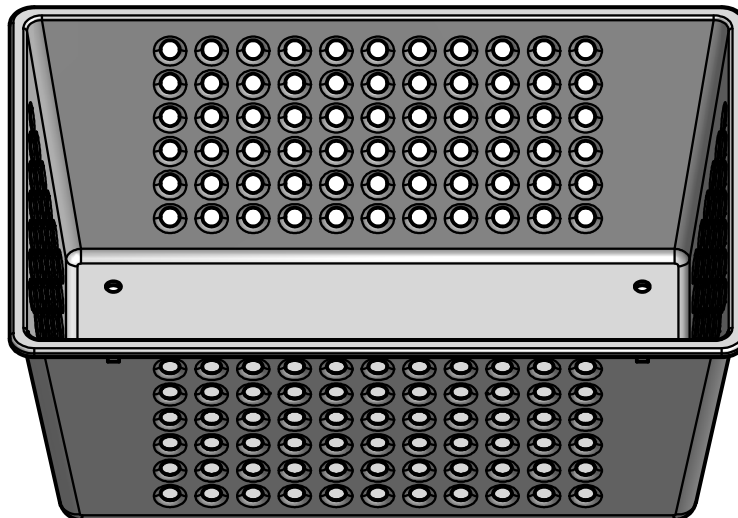

(1) FRUIT BASKET KIT - A6P00069

# PRE-ASSEMBLY STEP 1 - SORTING PARTS

It is critical for ease of assembly that you take the time to sort and organize the wood and hardware.

---

## WOOD PARTS:

- Organize wood parts by the three-digit, alpha-numeric number stamped on each board (ex. P01).
- If there are multiple boards with the same stamped number, stack those pieces together.
- Stamps can be found on the flat surface of the boards or on the end of the boards.
- Allow yourself plenty of room - the wood pieces can take up a significant amount of space.

**NOTE: CARTONS ARE NOT ORGANIZED BY BOARD NUMBER.**

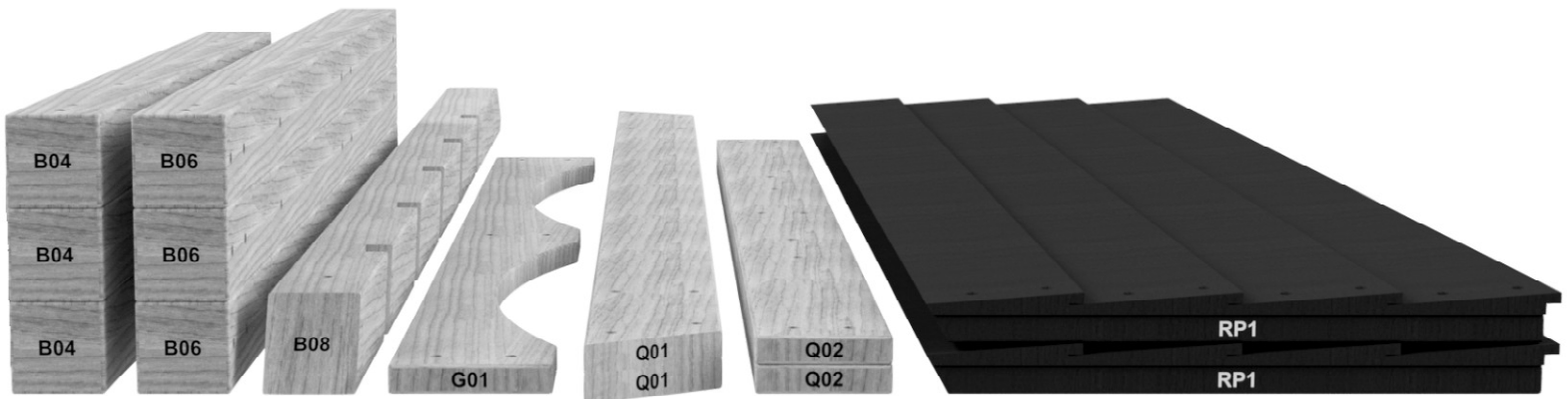

---

## HARDWARE PARTS:

- We recommend that you have a separate table to organize the hardware.
- Hardware bags are printed with a seven-digit, alpha-numeric part number.
- You can organize your hardware by part number or group by hardware type (i.e. bolts, nuts, etc.).
- During assembly you only need to reference the last four digits of the number.

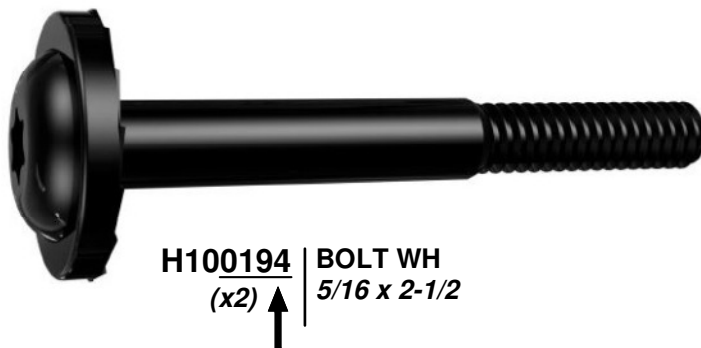

# PRE-ASSEMBLY STEP 2 - TOOLS REQUIRED



**Cordless Drill or  
Electric Drill**



**Drill Attachments:  
Phillips Head**



**1/8", 3/16", 3/8" & 7/16"  
Drill Bits**



**Phillips Screw Driver**



**Open End Wrenches 1/2" & 9/16"**



**3/8" Drive Ratchet, 1/2" &  
9/16" STD Sockets 1/2" & 9/16" Deep  
Sockets**



**Claw Hammer**



**Rubber Mallet - Optional**



**Tape Measure**

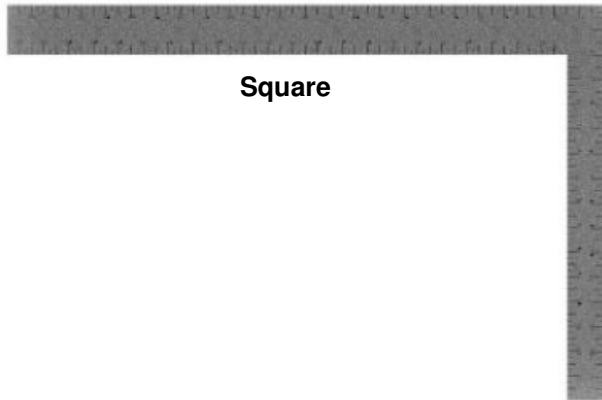

**Square**



**Level 24"**

# PRE-ASSEMBLY STEP 3 - CHOOSE YOUR ASSEMBLY METHOD

There are several types of assembly instructions available to you.

1. **Printed Assembly Manual** included with your set
2. **BILT APP** - 3D interactive instructions
3. **Combination of the Printed Manual and BILT APP** (Note: Step numbers can differ between the two methods)

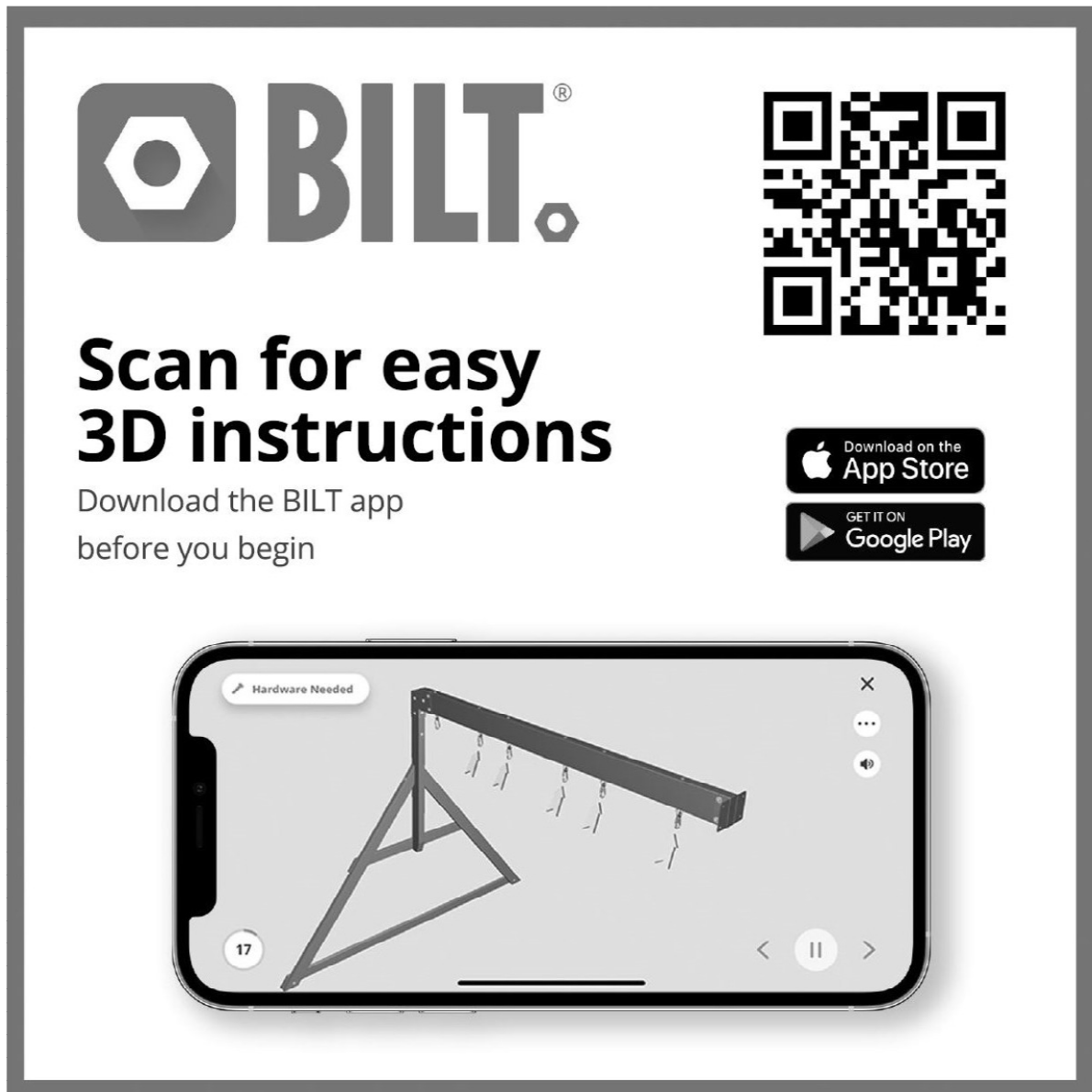

The advertisement features the BILT logo (a hexagon with a dot) and the word "BILT." in a large, bold, sans-serif font. To the right is a large QR code. Below the logo, the text "Scan for easy 3D instructions" is written in a large, bold font, followed by "Download the BILT app before you begin" in a smaller font. To the right of this text are two buttons: "Download on the App Store" and "GET IT ON Google Play". At the bottom, a smartphone screen displays a 3D assembly instruction for step 17, showing a metal frame with a horizontal bar and several hanging components. The screen includes a "Hardware Needed" label, a close button (X), a menu button (three dots), a volume icon, and navigation arrows.

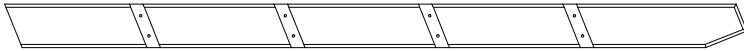

(1) H77 - LEFT UPRIGHT - W4L07617  
1"x3 3/8"x58" (24x86x1474)



(4) H76 - LADDER RUNG - W4L07620  
1"x3 3/8"x17 1/4" (24x86x437)

# 4 FT LADDER WITH ATTACHMENT BOARD

## STEP 1

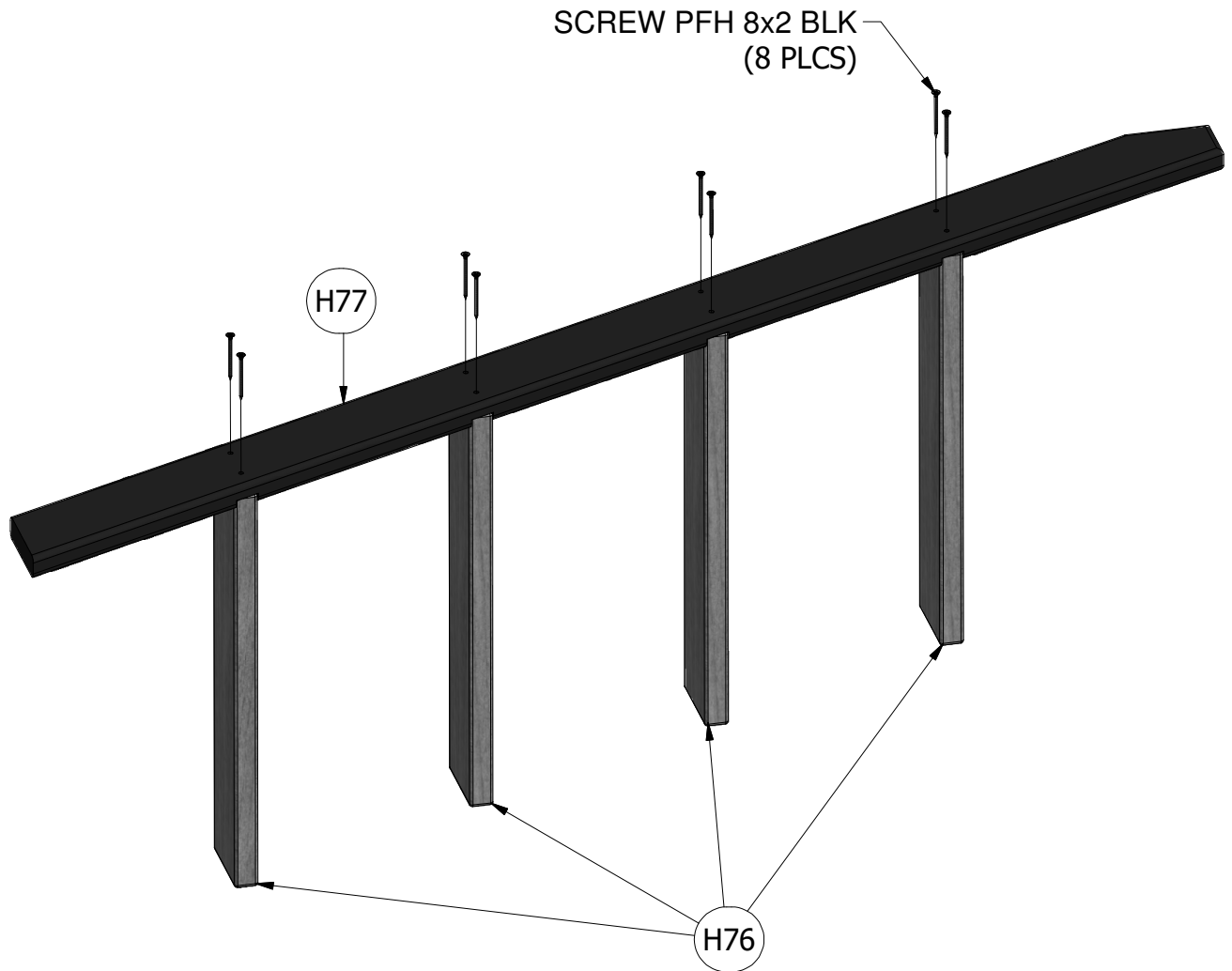
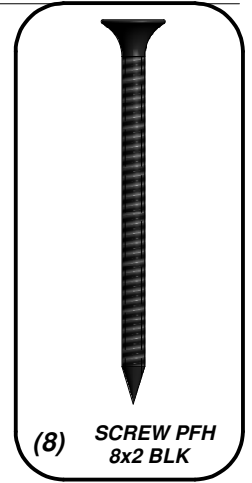



(1) **H78 - RIGHT UPRIGHT - W4L07618**  
1"x3 3/8"x64 3/8" (24x86x1634)

**STEP 2**

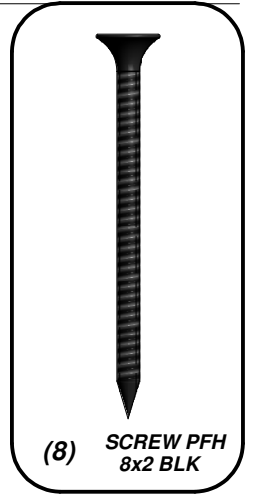

SCREW PFH 8x2 BLK  
(8 PLCS)

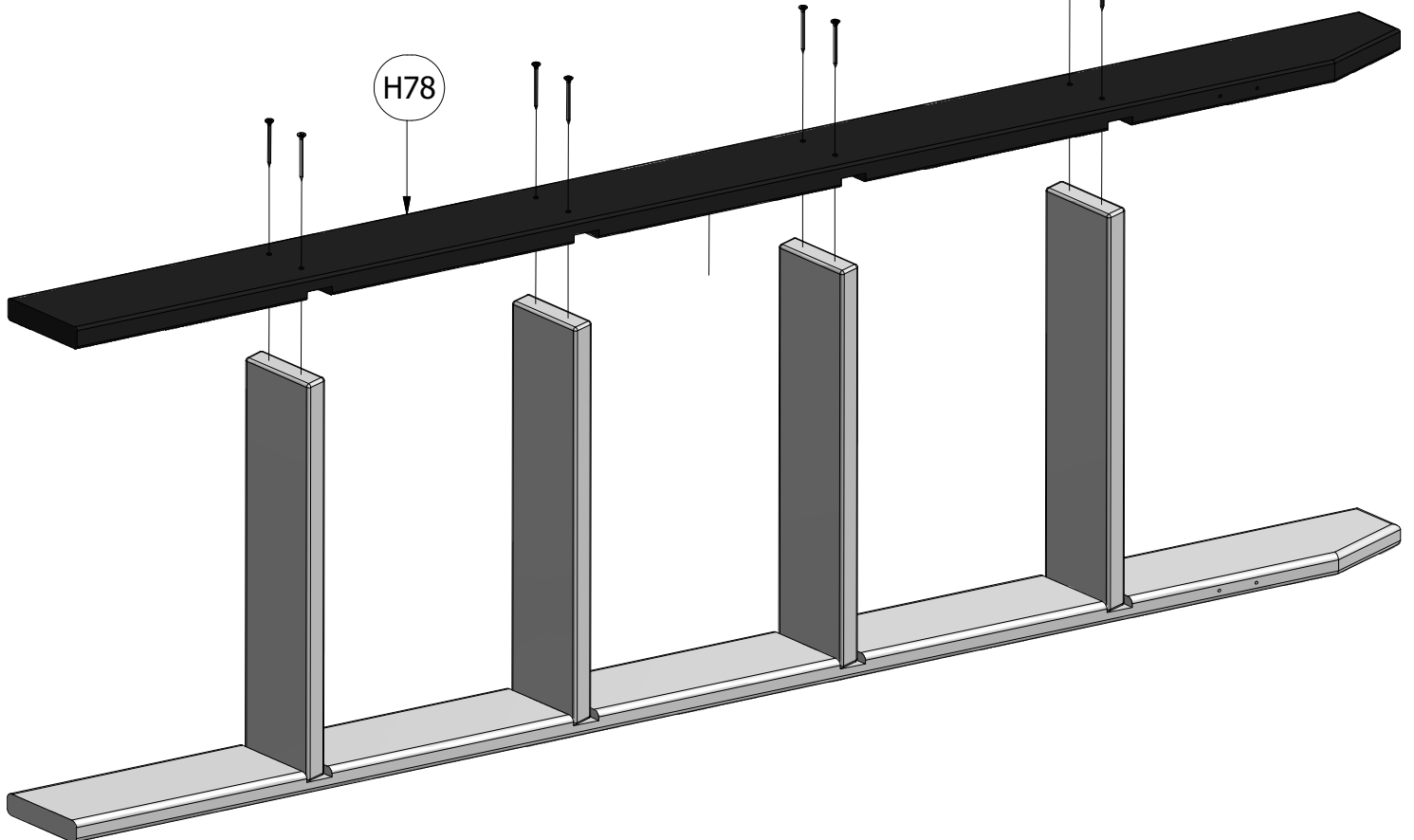



(1) **M110 - ATTACHMENT BOARD - W4L07621**  
5/8"x3 3/8"x18 1/4" (16x86x465)



(1) **M73 - REAR SUPPORT - W4L07619**  
5/8"x3 3/8"x18 1/4" (16x86x465)

**STEP 3**

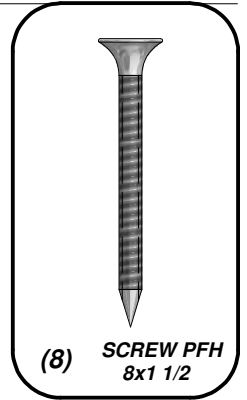

SCREW PFH 8x1 1/2  
(8 PLCS)

63 mm [2 1/2 in]

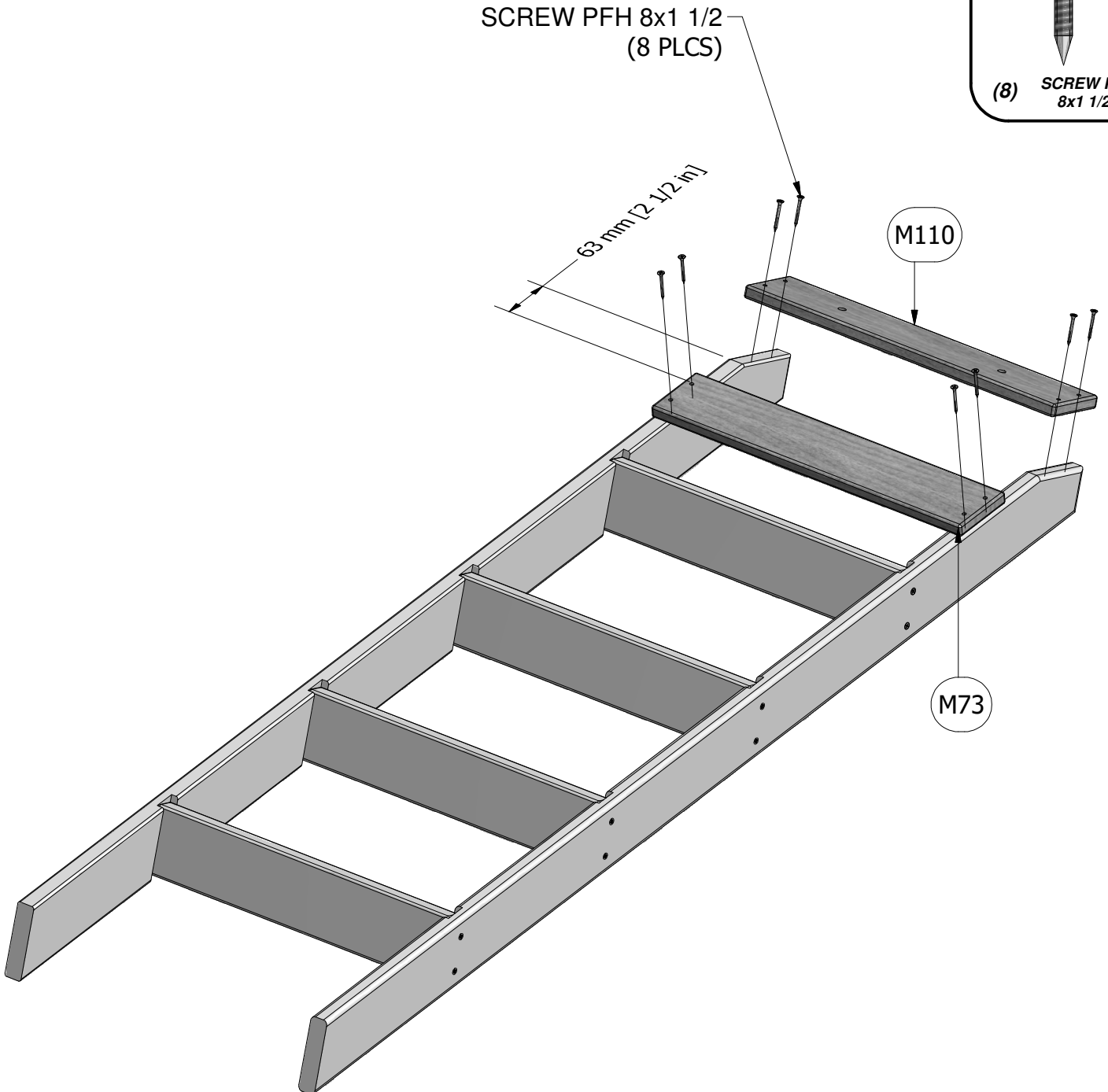

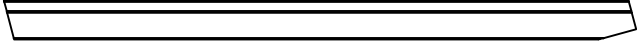

(1) E72 - LEFT RAIL - W4L07622  
1 3/8"x3 3/8"x54 7/8" (36x86x1395)

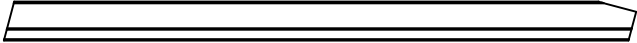

(1) E73 - RIGHT RAIL - W4L07623  
1 3/8"x3 3/8"x54 7/8" (36x86x1395)



(1) M108 - TOP BOARD - W4L07625  
5/8"x3 3/8"x26 1/4" (16x86x667)



(8) M74 - ROCK WALL BOARD - W4L07624  
5/8"x3 3/8"x25" (16x86x635)



(4) M75 - ROCK WALL BOARD - W4L07627  
5/8"x3 3/8"x25" (16x86x635)



(4) M76 - ROCK WALL BOARD - W4L07626  
5/8"x3 3/8"x25" (16x86x635)

# ROCKWALL STEP 1

SCREW PFH 8x1 1/2  
(64 PLCS)

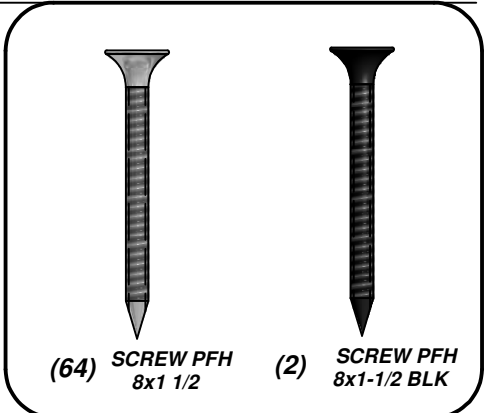
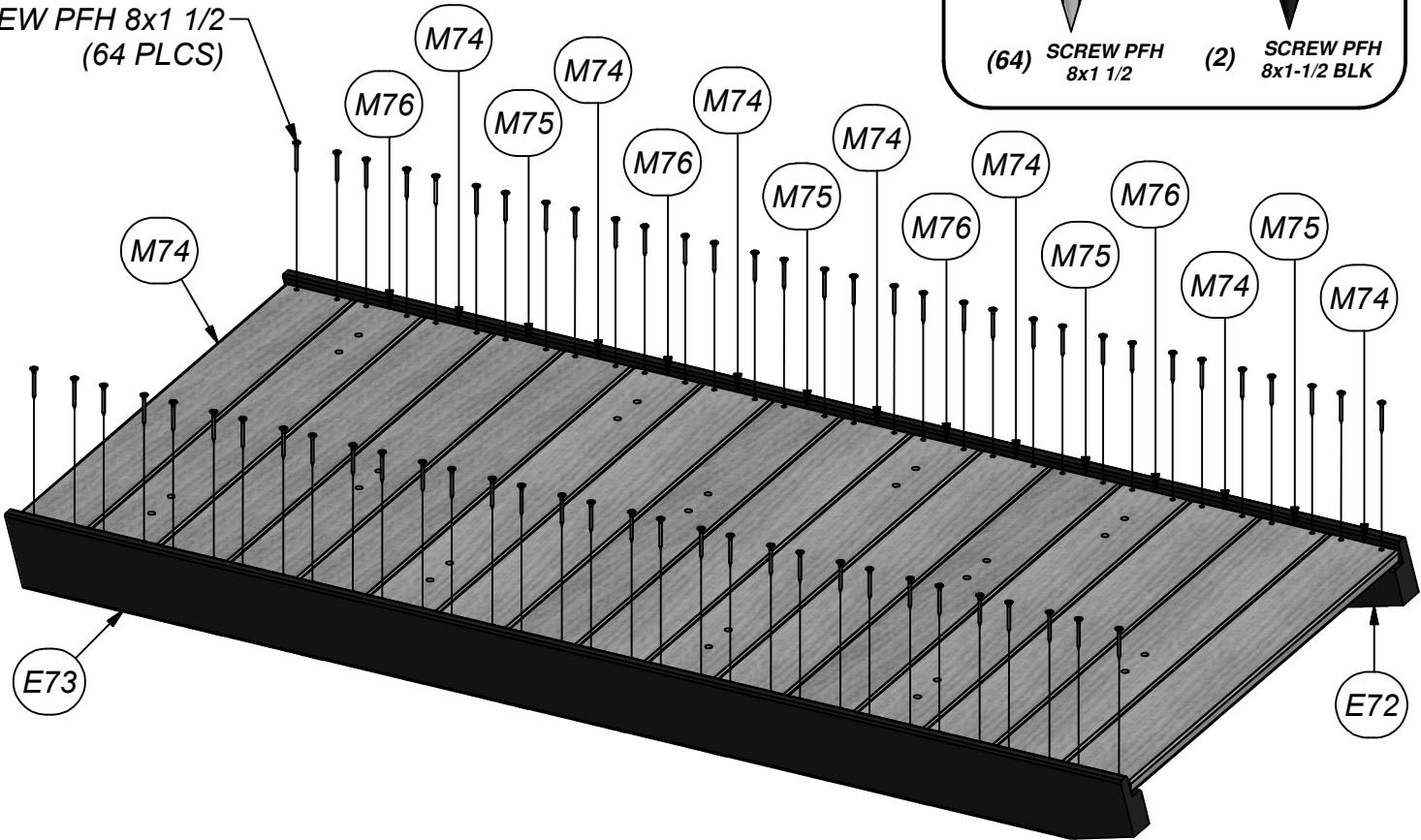

SCREW PFH 8x1-1/2 BLK  
(2 PLCS)

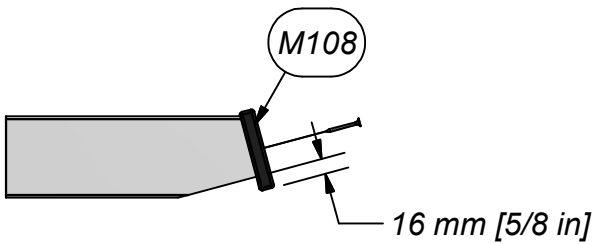
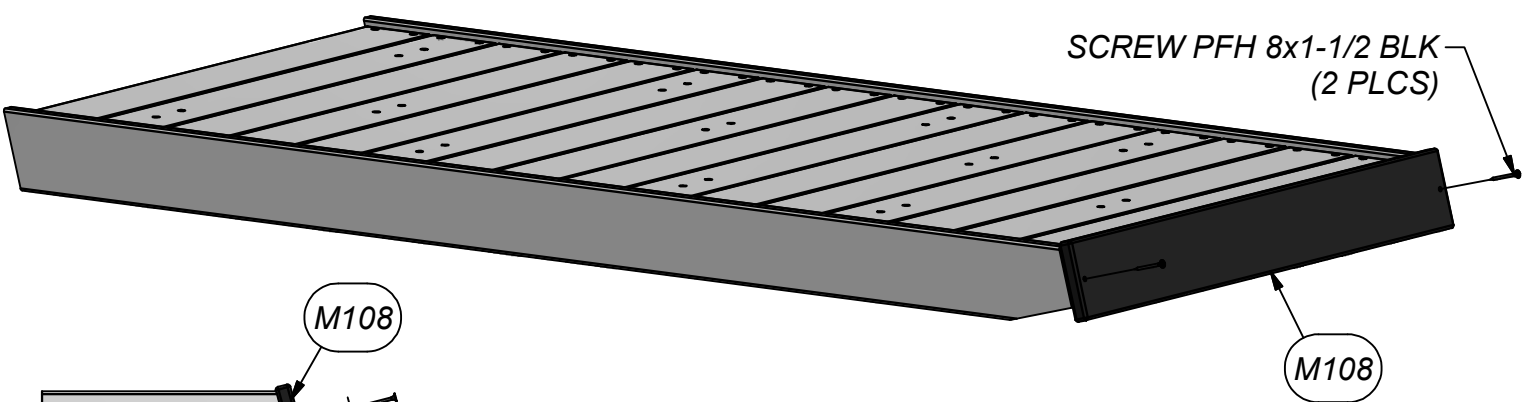

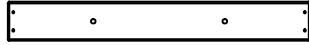

- (1) **M102 - ATTACHMENT BOARD - W4L07628**  
5/8"x3 3/8"x26 1/4" (16x86x667)

**ROCKWALL**  
**STEP 2**

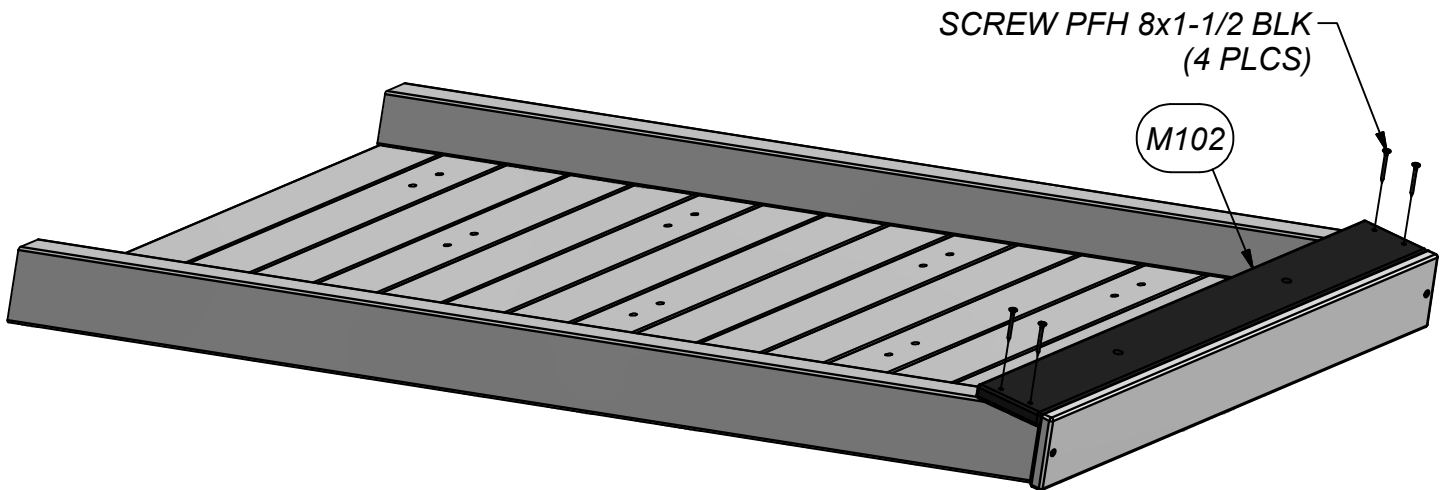
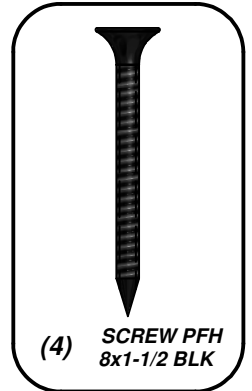



(3) - GREEN HC ROCK #1 - A6P00036



(3) - RED HC ROCK #1 - A6P00038



(3) - BLUE HC ROCK #2 - A6P00040

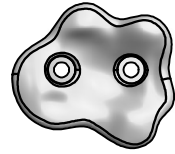

(3) - YELLOW HC ROCK #1 - A6P00042

### ROCKWALL STEP 3

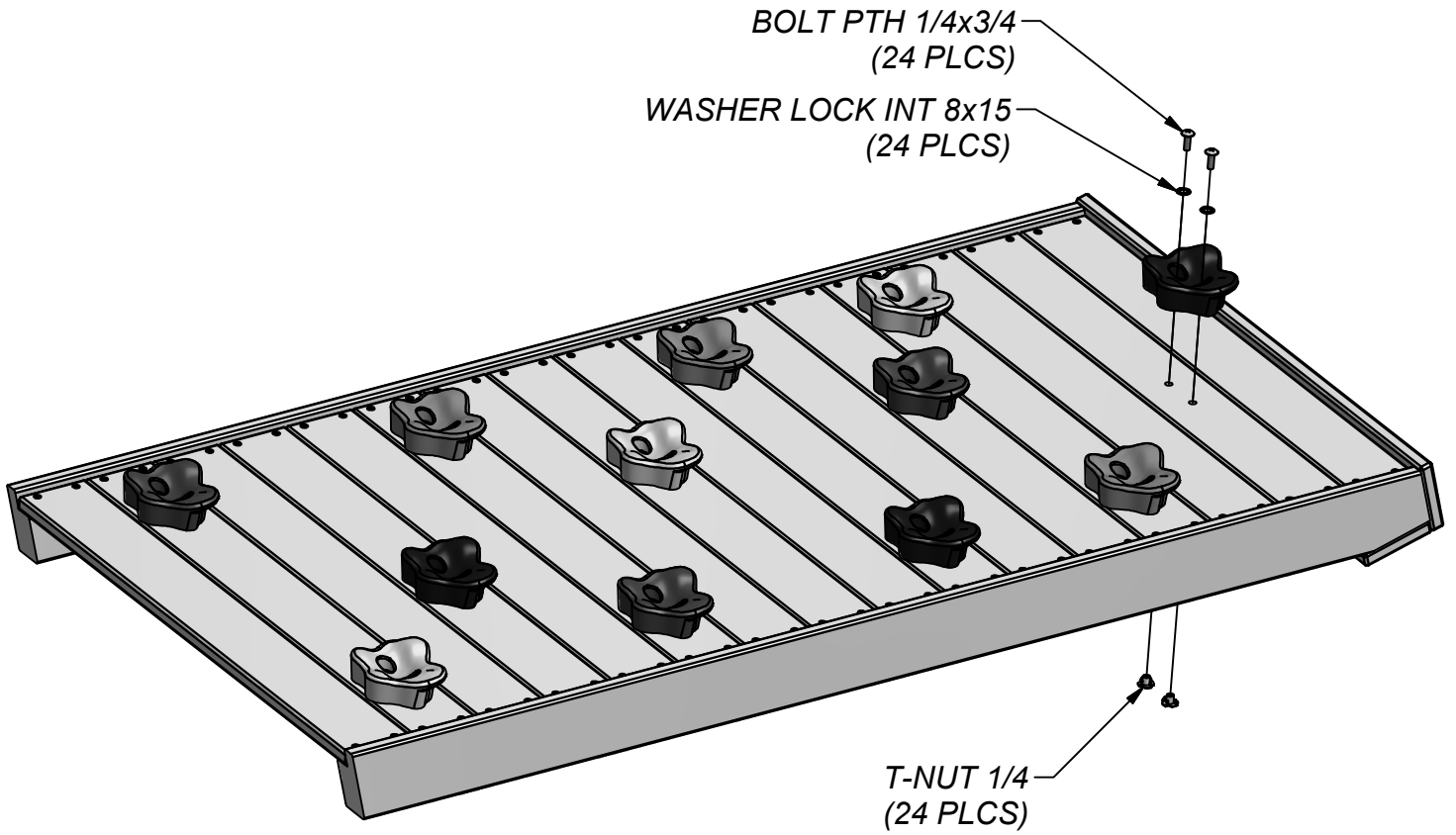
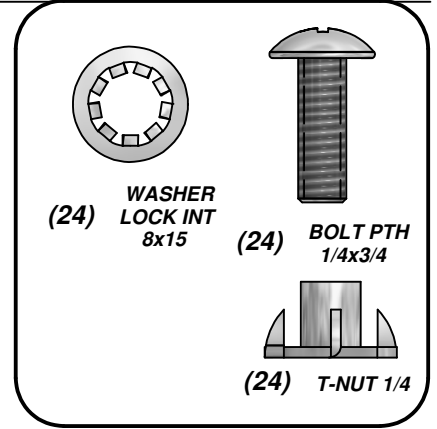

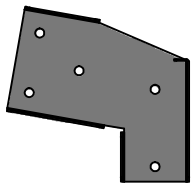

(1) **SB74 - SWING BEAM EXTENDED - W4L07633**  
 2"x5 1/4"x89 1/2" (50x134x2274)

(1) **TC - SWING BEAM EXTENSION BRACKET-RIGHT - A100326**

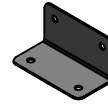
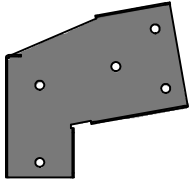

(2) **GD - L BRACKET 66x66x127 - A100140**

(1) **TB - SWING BEAM EXTENSION BRACKET-LEFT - A100325**

**SWING BEAM ASSEMBLY  
 STEP 1**

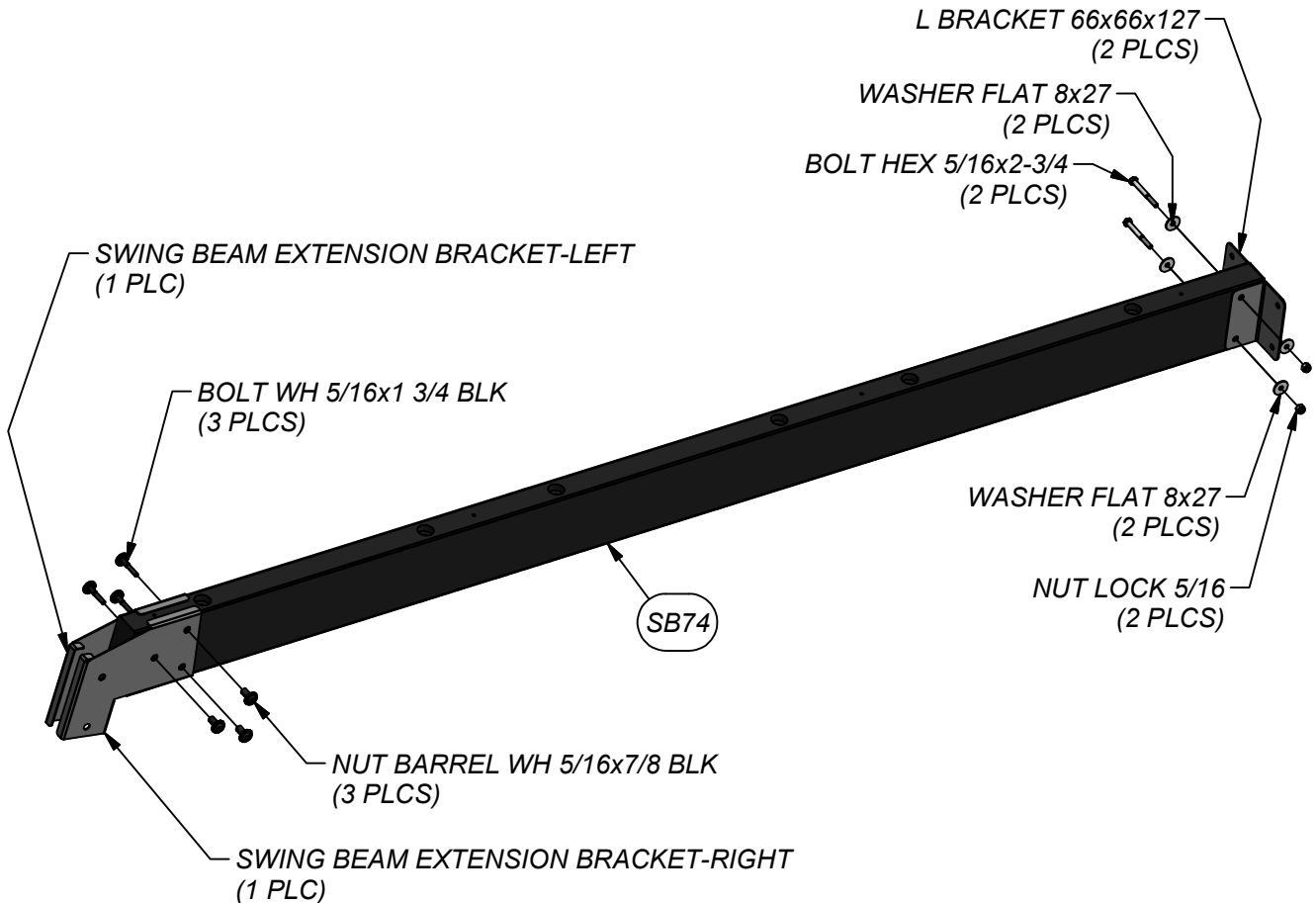
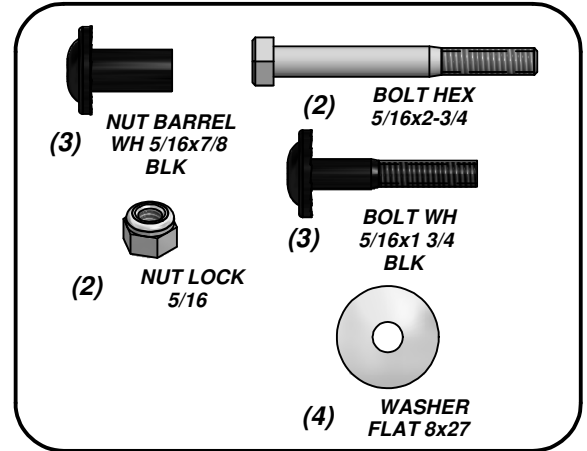



(1) H80 - GROUND BOARD - W4L07630  
1"x3 3/8"x87 3/8" (24x86x2218)

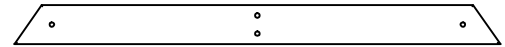

(1) H79 - END SUPPORT - W4L07632  
1"x3 1/2"x42" (24x86x1072)

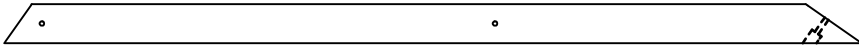

(2) E77 - ANGLE BRACE - W4L07631  
1 3/8"x3 3/8"x74 3/8" (36x86x1890)

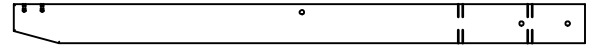

(1) W71 - SWING BEAM SUPPORT - W4L07629  
2"x3 3/8"x49 5/8" (50x86x1260)

## SWING BEAM ASSEMBLY STEP 2

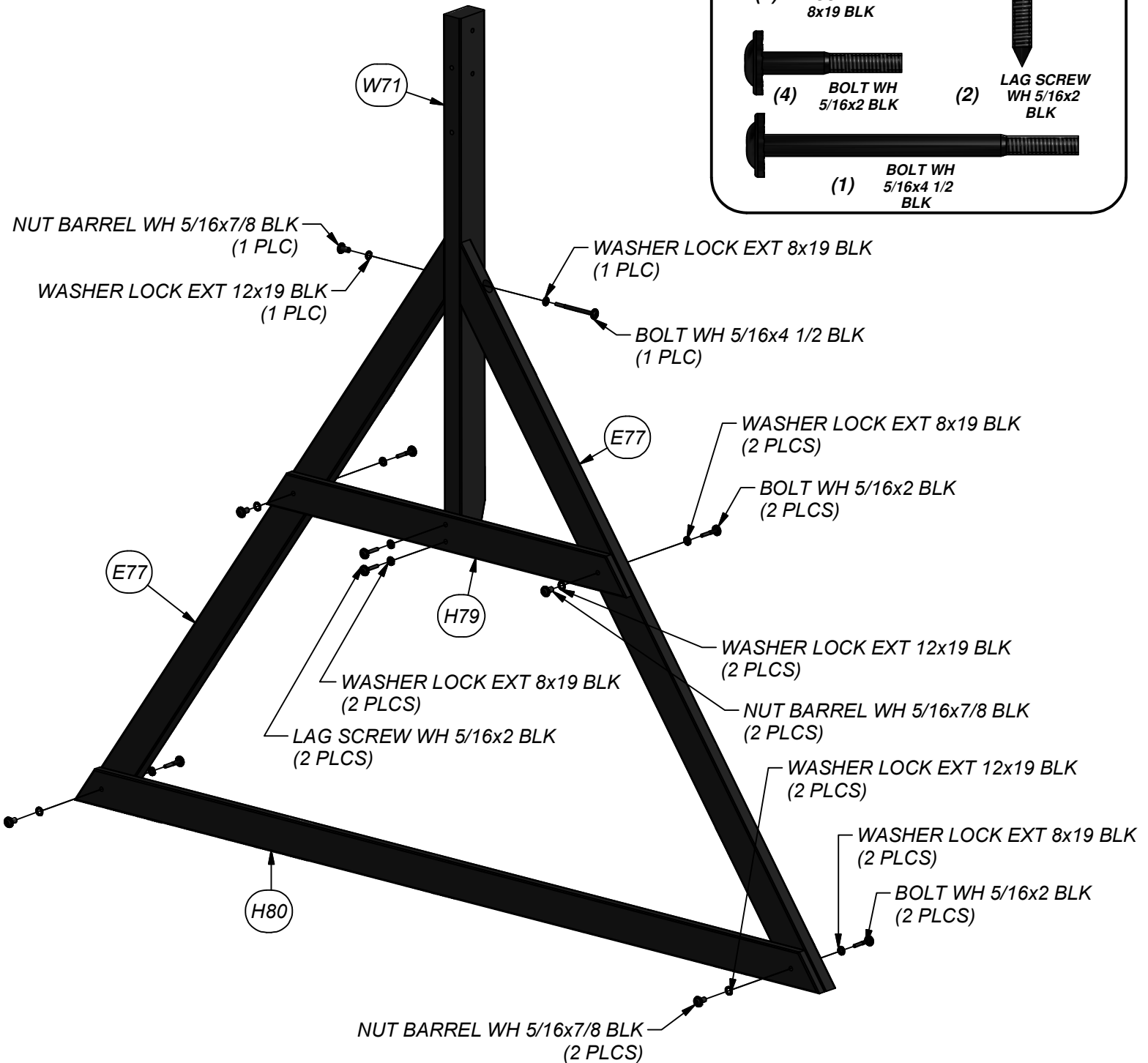
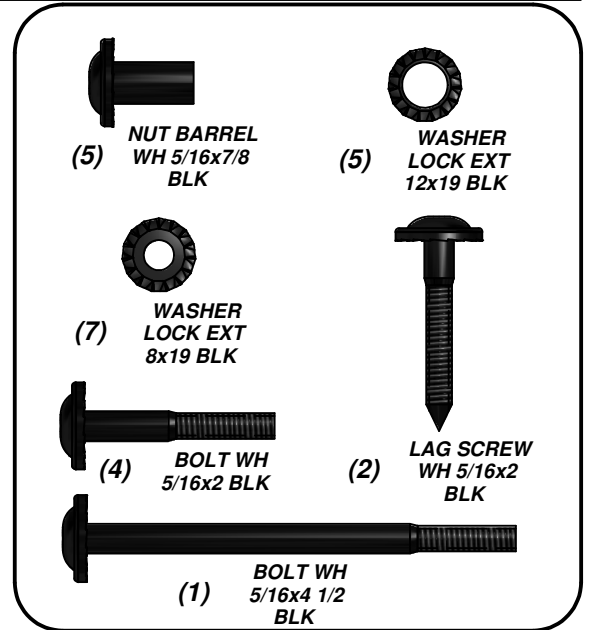

**SWING BEAM ASSEMBLY  
STEP 3**

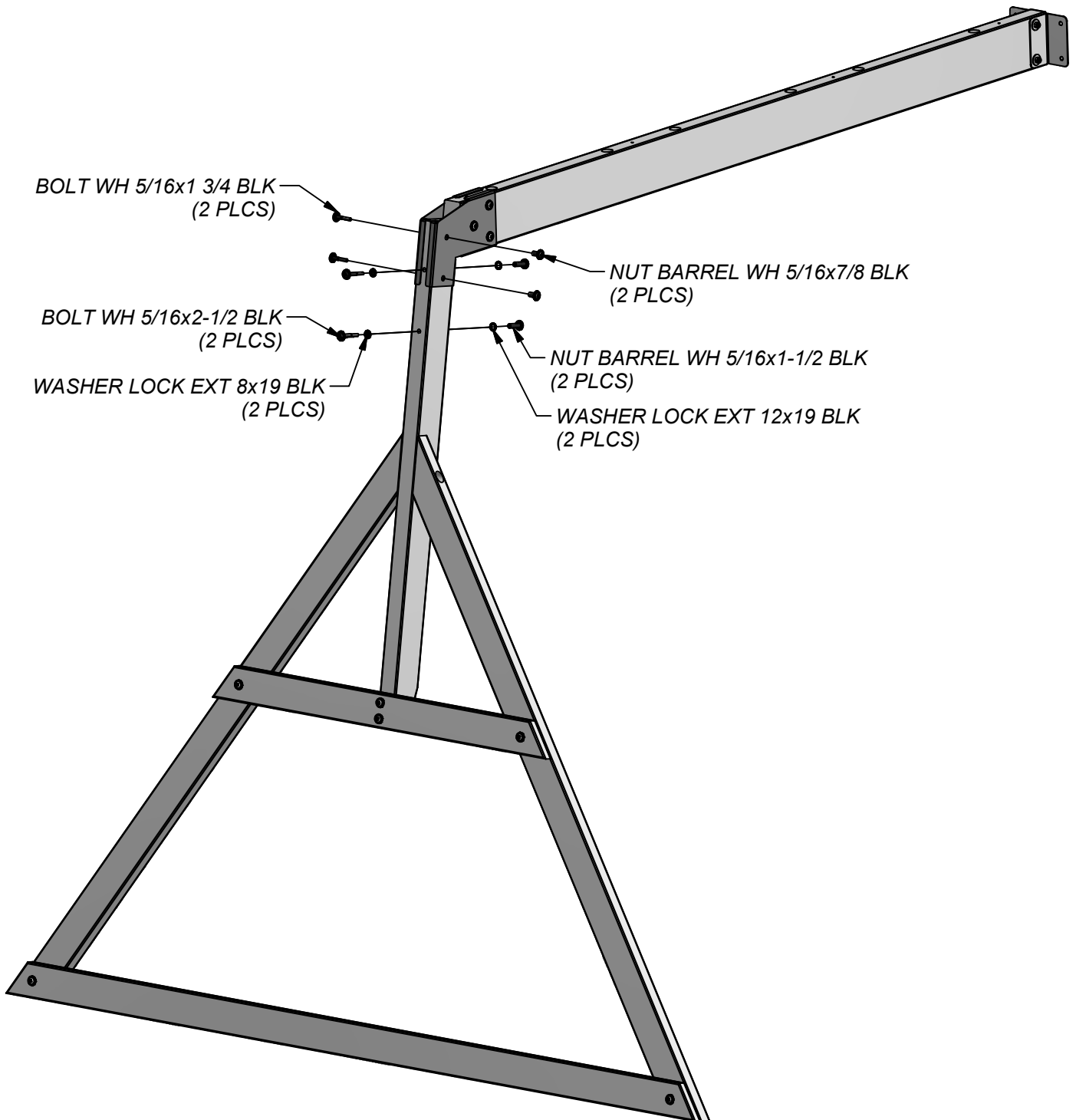
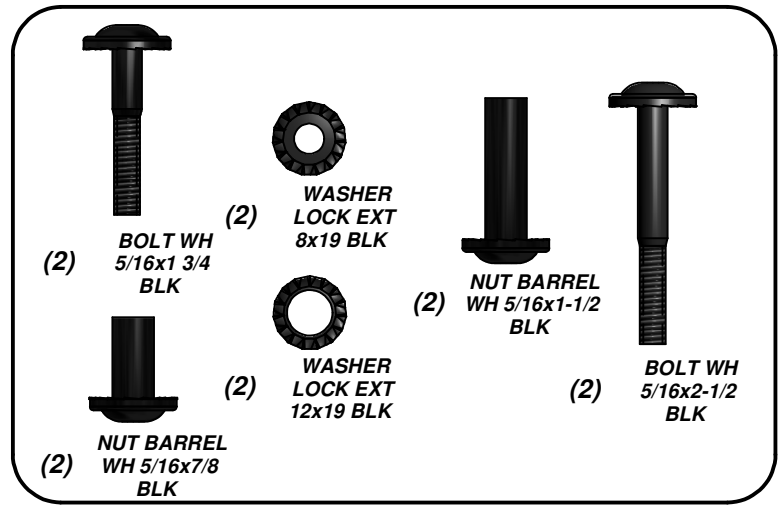

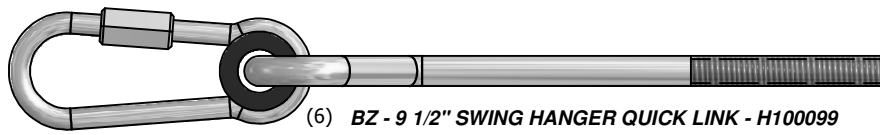

(6) BZ - 9 1/2" SWING HANGER QUICK LINK - H100099

### SWING BEAM ASSEMBLY STEP 4

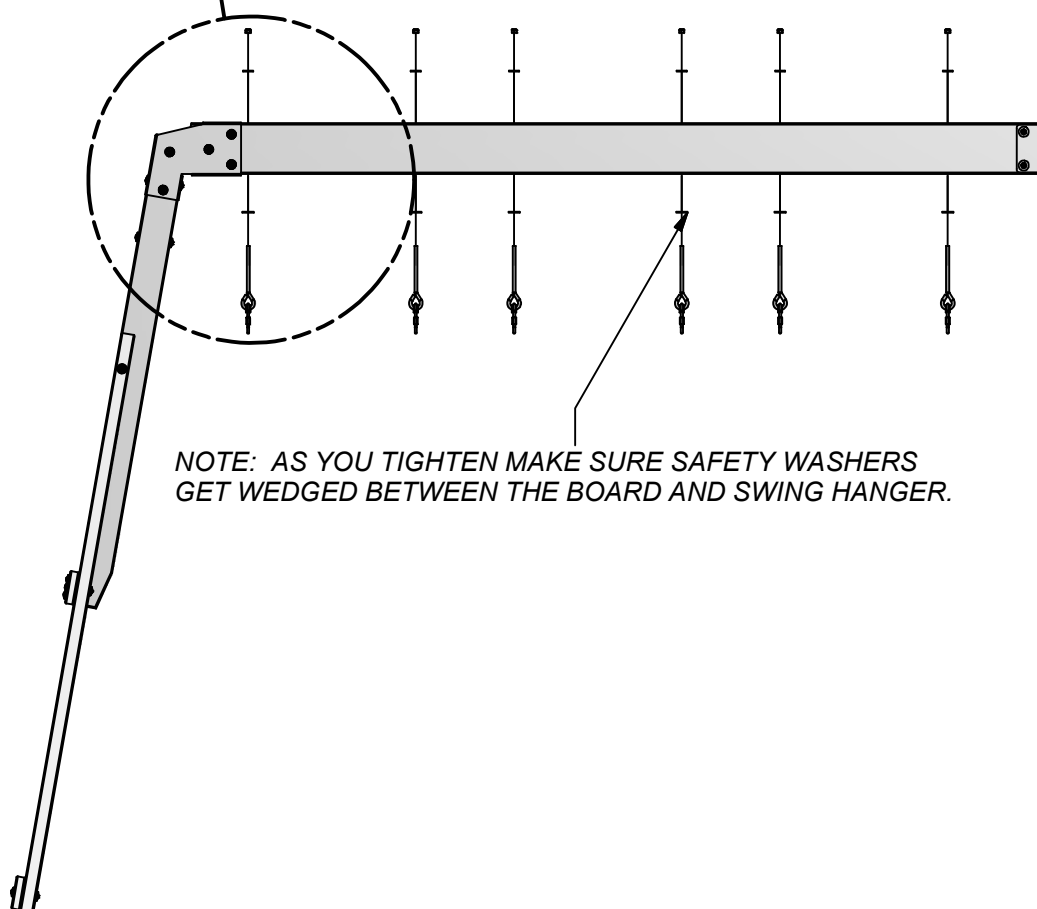
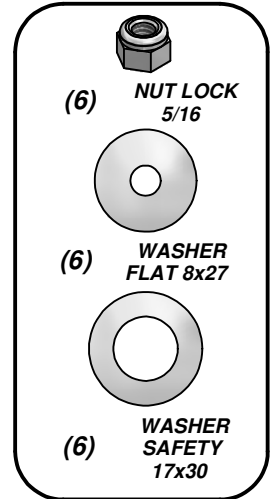
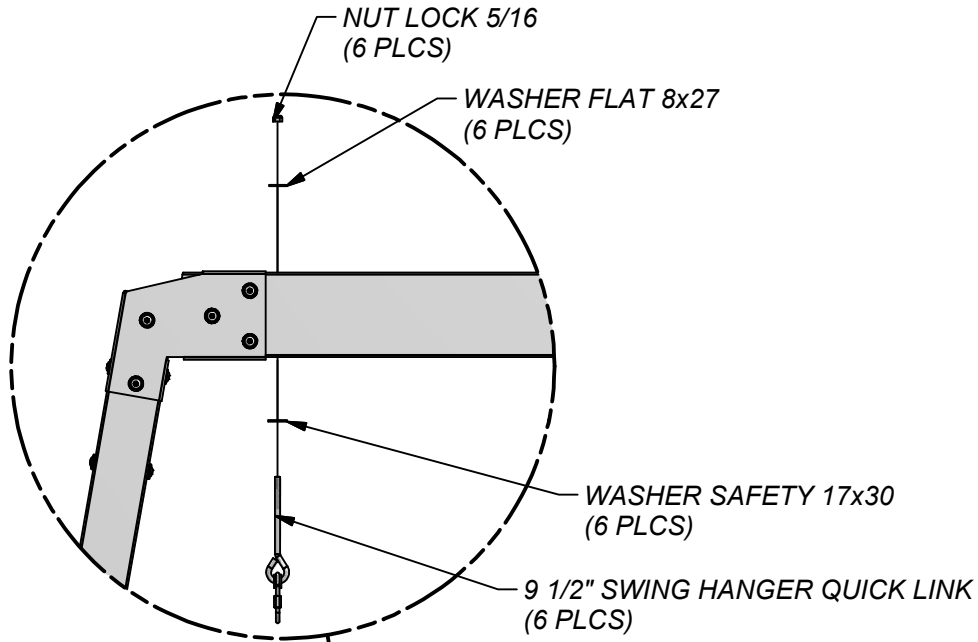

NOTE: AS YOU TIGHTEN MAKE SURE SAFETY WASHERS GET WEDGED BETWEEN THE BOARD AND SWING HANGER.



**A100035** | SLIDE BED 10' LIGHT GREEN  
(x1)

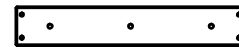

**M70** | SLIDE SUPPORT BOARD - W100935  
(x1) 5/8"x3 3/8"x19 7/8" (16x86x505)



**H100074** | T-NUT  
(x3) 5/16"



**H100115** | BOLT WH  
(x3) 5/16x1/2"



**NOTE:**

TAKE NOTE OF SLIDE BED SURFACE FINISH, THE DULL SIDE WILL BE TOWARDS THE GROUND. PLACE SLIDE BRACE CENTERED ON THE BOTTOM (DULL SIDE) AND 1/2" FROM THE EDGE. USE **M70** BOARD AS A TEMPLATE FOR DRILLING BOTTOM HOLE PATTERN IN SLIDE BED. USE A 5/16" DRILL BIT.



**TIP:**

PRE-BENDING THE ENDS WILL EASE ASSEMBLY. PLACING THE SLIDE BED OUT IN THE SUN MAKES IT EASIER TO BEND.

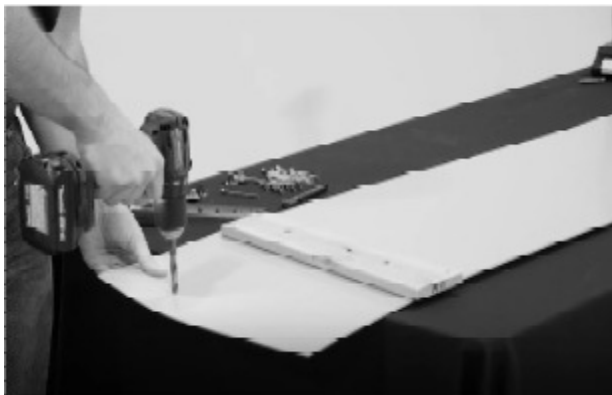
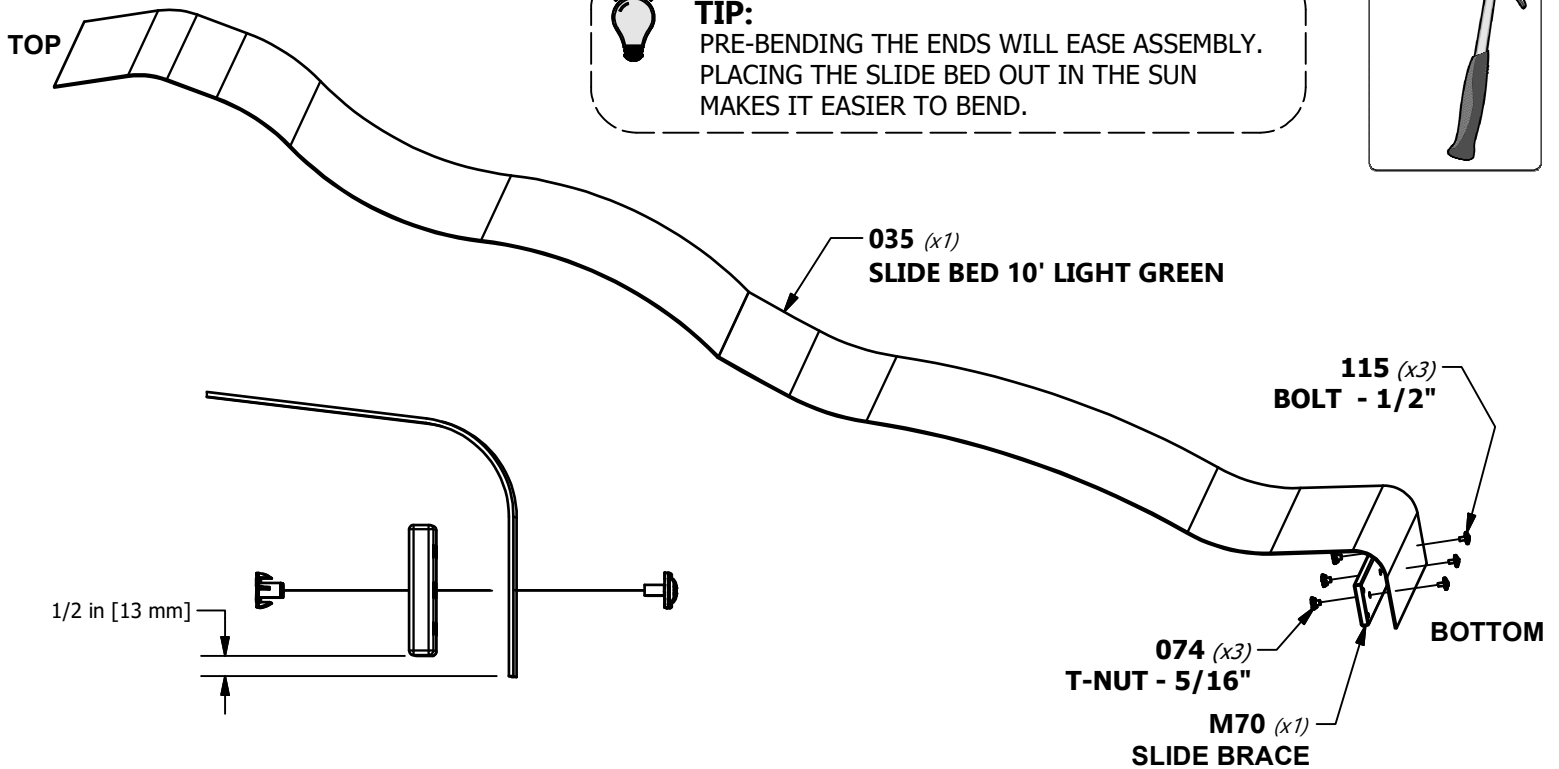
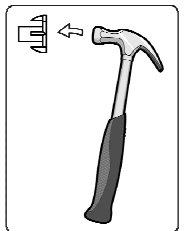



# SLIDE ASSEMBLY

## STEP 2



A6P00484 | SLIDE RAIL 10' BOTTOM RIGHT GREEN  
(x1)



A6P00486 | SLIDE RAIL 10' TOP RIGHT GREEN  
(x1)



A6P00483 | SLIDE RAIL 10' BOTTOM LEFT GREEN  
(x1)



A6P00485 | SLIDE RAIL 10' TOP LEFT GREEN  
(x1)



H100115 | BOLT WH  
(x8) | 5/16x1/2

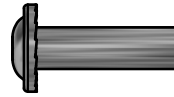

H100006 | NUT BARREL WH  
(x8) | 5/16x1 1/2



**NOTE:**  
REPEAT ON OTHER SIDE, MAKING  
A LEFT AND RIGHT ASSEMBLY.

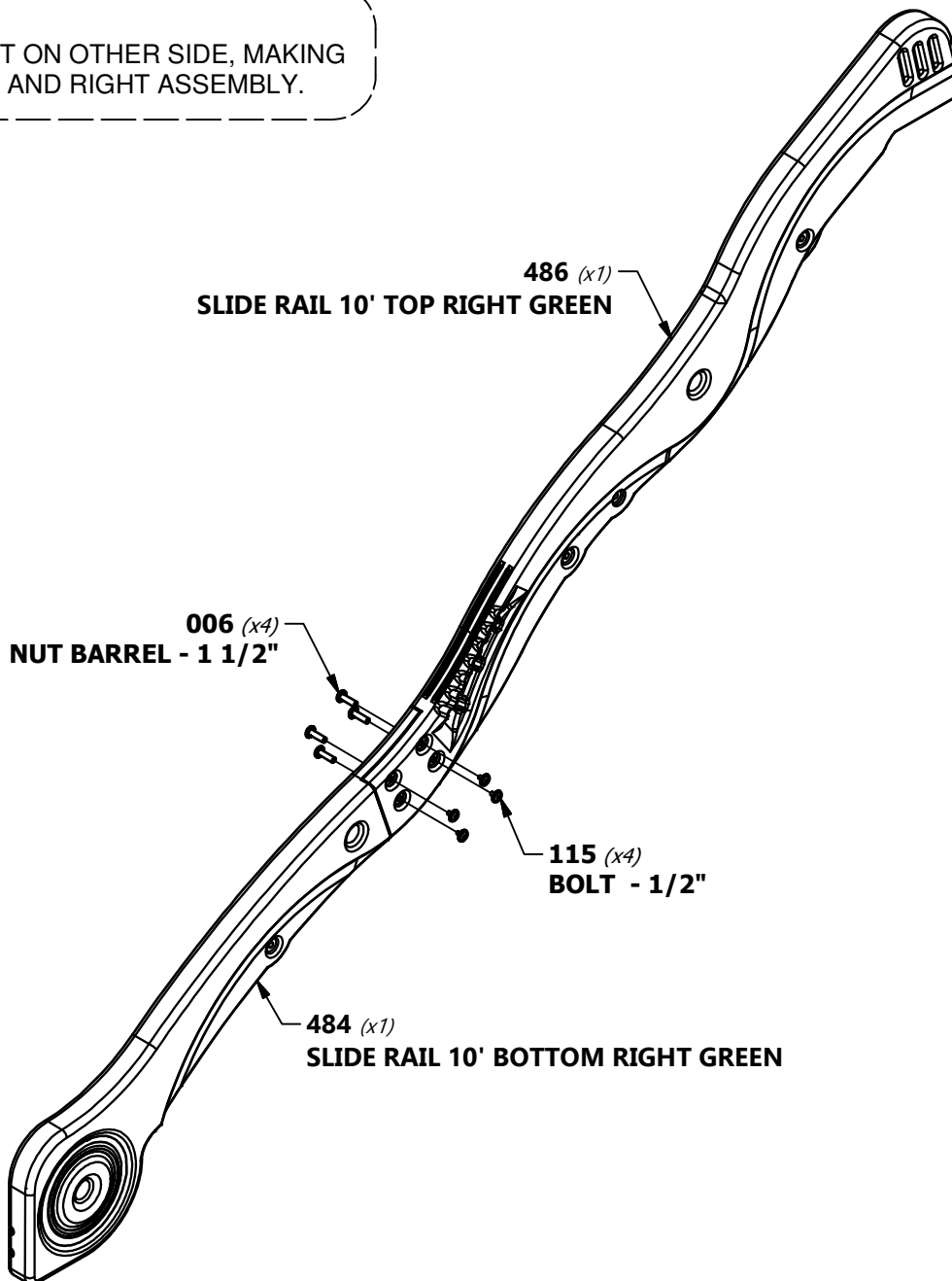

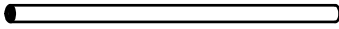

  
**A6P00487** | SLIDE TUBE SUPPORT  
 (x4)

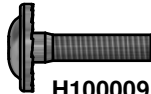
  
**H100009** | BOLT WH  
 (x4) | 5/16x1 1/4

**NOTE:**

INSERT THE (4) SLIDE SUPPORT TUBES INTO THEIR RESPECTIVE PILOT LOCATIONS (FIGURE 1).

PLACE (1) SLIDE RAIL ASSEMBLY ON A FLAT SURFACE AND BEGIN INSERTING SLIDE BED AT THE BOTTOM OF THE SLIDE RAIL (FIGURE 2). HAVE A HELPER BEND THE SLIDE BED TOWARDS THE TOP OF THE SLIDE AND INSERT THE BED INTO THE SLIDE CAVITY. MAKE SURE SLIDE BED IS INSERTED WITHIN 1/8" (3mm) OF GROOVE BOTTOM.

**TIP:**

A HELPER IS RECOMMENDED FOR THESE FOLLOWING STEPS.

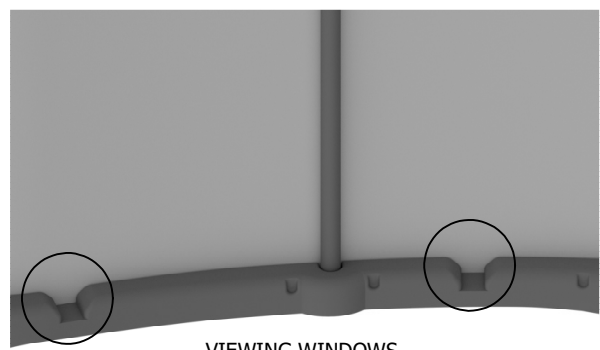
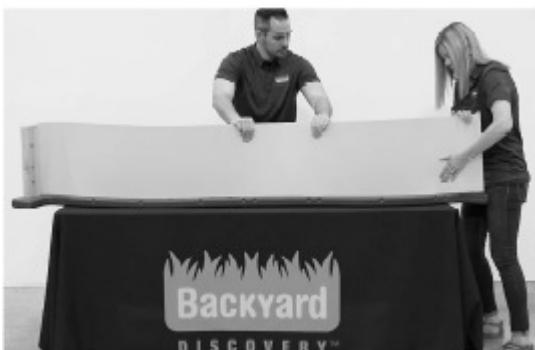
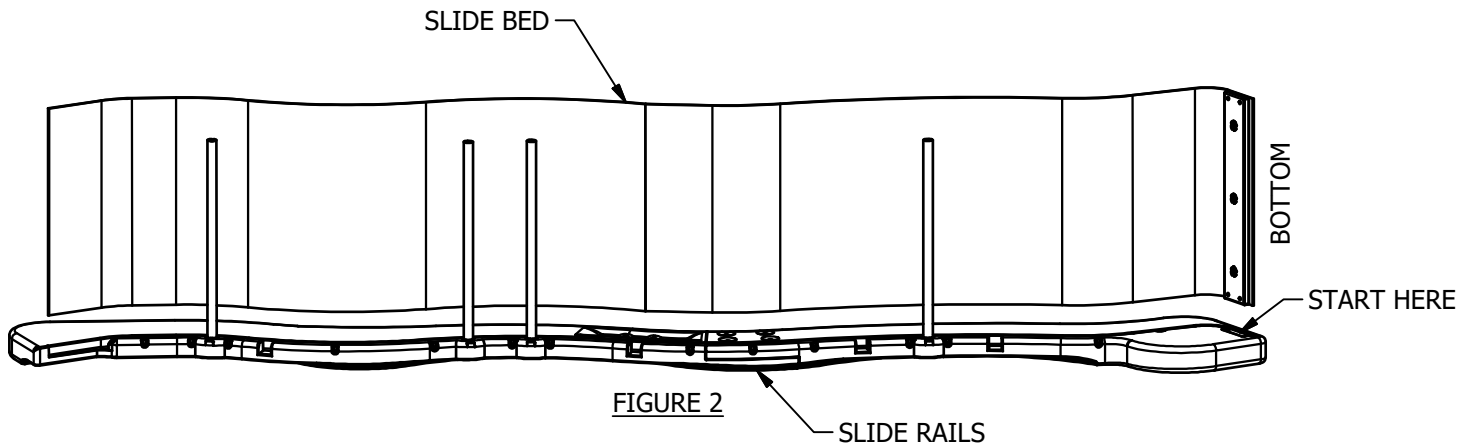
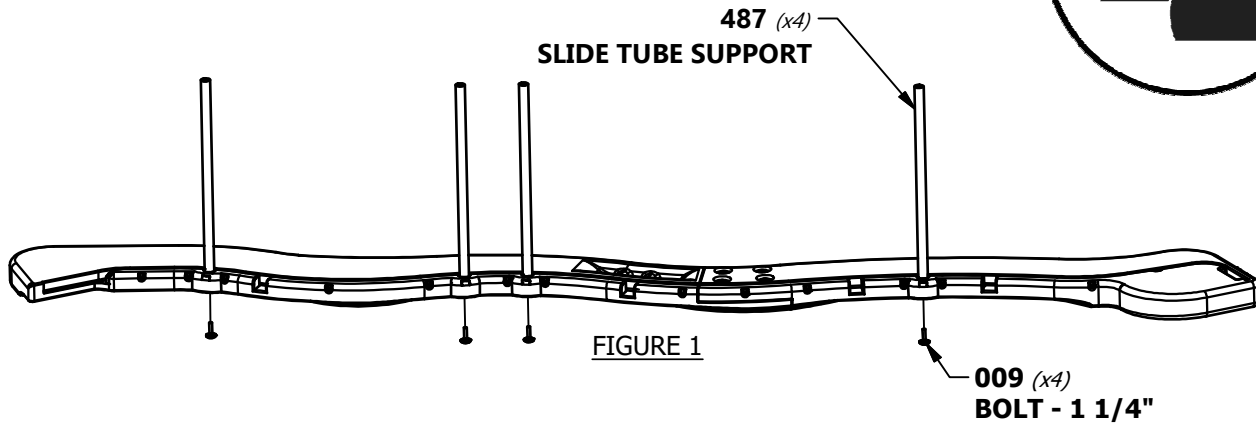



**NOTE:**

PLACE SECOND SLIDE RAIL ASSEMBLY OVER THE TOP OF THE SLIDE BED AND SLIDE SUPPORT TUBES. INSERT THE SLIDE BED AND SLIDE SUPPORT TUBES INTO THE SLIDE CAVITY. MAKE SURE SLIDE BED IS INSERTED WITHIN 1/8" (3mm) OF GROOVE BOTTOM.



**FAILURE TO INSERT SLIDE BED PROPERLY MAY RESULT IN INJURY OR AMPUTATION. EXPOSED SLIDE EDGES CAN BE SHARP AND BECOME A LACERATION HAZARD IF THE SLIDE IS NOT PROPERLY ASSEMBLED.**

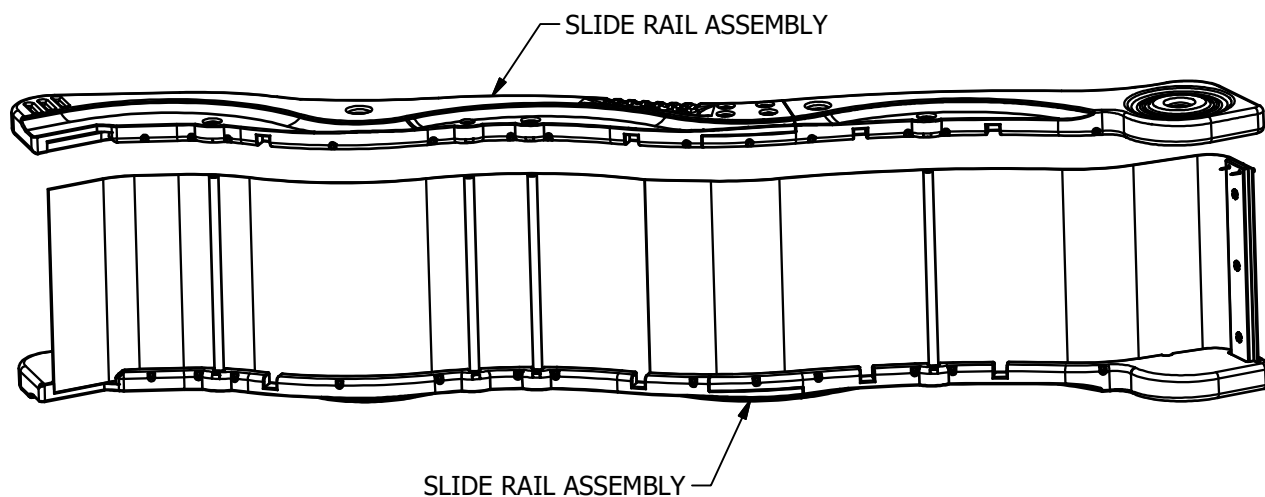

**TIP:**

USE A RUBBER Mallet TO FULLY SEAT THE SLIDE BED INTO THE SLIDE CAVITY.

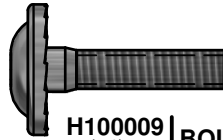

H100009 | BOLT WH 5/16x1 1/4  
(x4)



**NOTE:**  
USE 1 1/4" BOLTS TO FASTEN EACH  
SIDE OF THE SLIDE SUPPORT TUBES.



**TIP:**  
HAVING A HELPER HOLD THE SLIDE  
ASSEMBLY TOGETHER WHILE YOU FASTEN  
WILL MAKE IT EASIER TO ASSEMBLE.

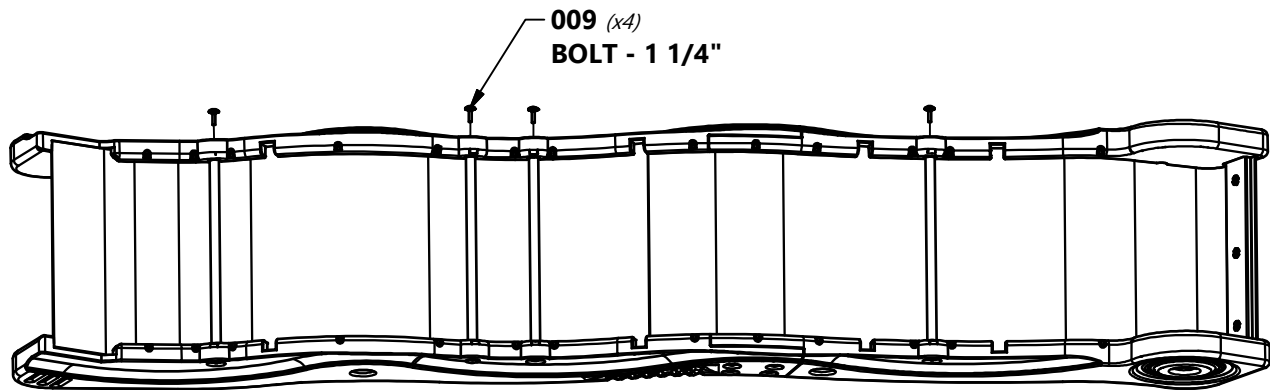
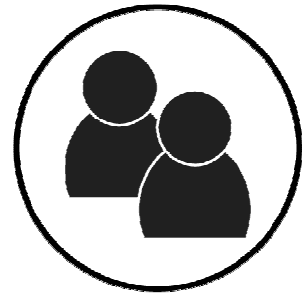



H100090 | SCREW PFH  
(x30) | 8x2 1/2"



**NOTE:**

USING AN 1/8" DRILL BIT, DRILL PILOT HOLES IN EACH INDENTATION ALONG EACH SIDE RAIL. THERE SHOULD BE 15 INDENTATIONS ON EACH RAIL. BE SURE TO DRILL THROUGH THE SLIDE RAIL AND THE SLIDE BED. THEN SECURE WITH THE PROVIDED HARDWARE.

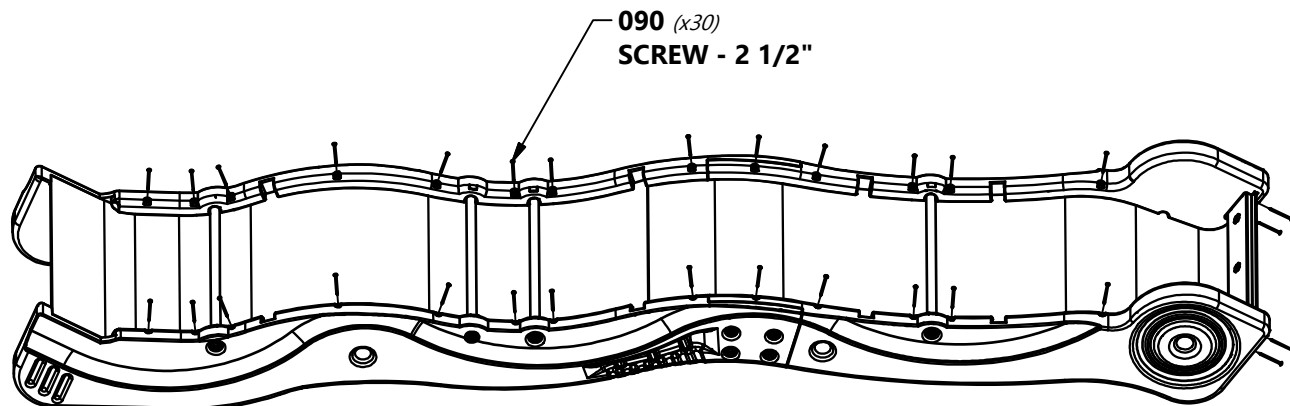

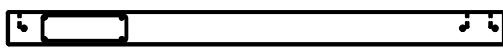

(1) E1 - RIGHT REAR UPRIGHT - W2A02080  
1 3/8"x3 3/8"x51 3/4" (36x86x1314)

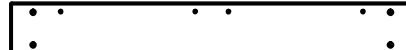

(1) K1 - GROUND BOARD - W4L07489  
5/8"x5 1/4"x41 7/8" (16x134x1064)



(1) G1 - SWING BEAM MOUNT - W4L07513  
1"x5 1/4"x62 1/8" (24x134x1577)

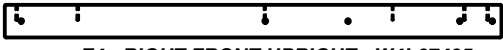

(1) E4 - RIGHT FRONT UPRIGHT - W4L07495  
1 3/8"x3 3/8"x51 3/4" (36x86x1314)

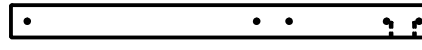

(1) E9 - RIGHT FRONT UPRIGHT - W4L07512  
1 3/8"x3 3/8"x43 1/2" (36x86x1104)



(1) K5 - RIGHT CENTER WALL RAIL - W4L07496  
5/8"x5 1/4"x62 3/4" (16x134x1593)



(1) E7 - RIGHT REAR UPRIGHT - W4L07510  
1 3/8"x3 3/8"x43 1/2" (36x86x1104)

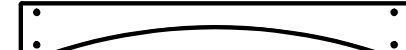

(1) K12 - ARCHED WALL RAIL - W4L07579  
5/8"x5 1/4"x40 5/8" (16x134x1032)



(1) SQ - "A" REVISION TAG - A100314

### STEP 1

INSTALL T-NUTS INTO PARTS BEFORE ASSEMBLY OF PARTS.

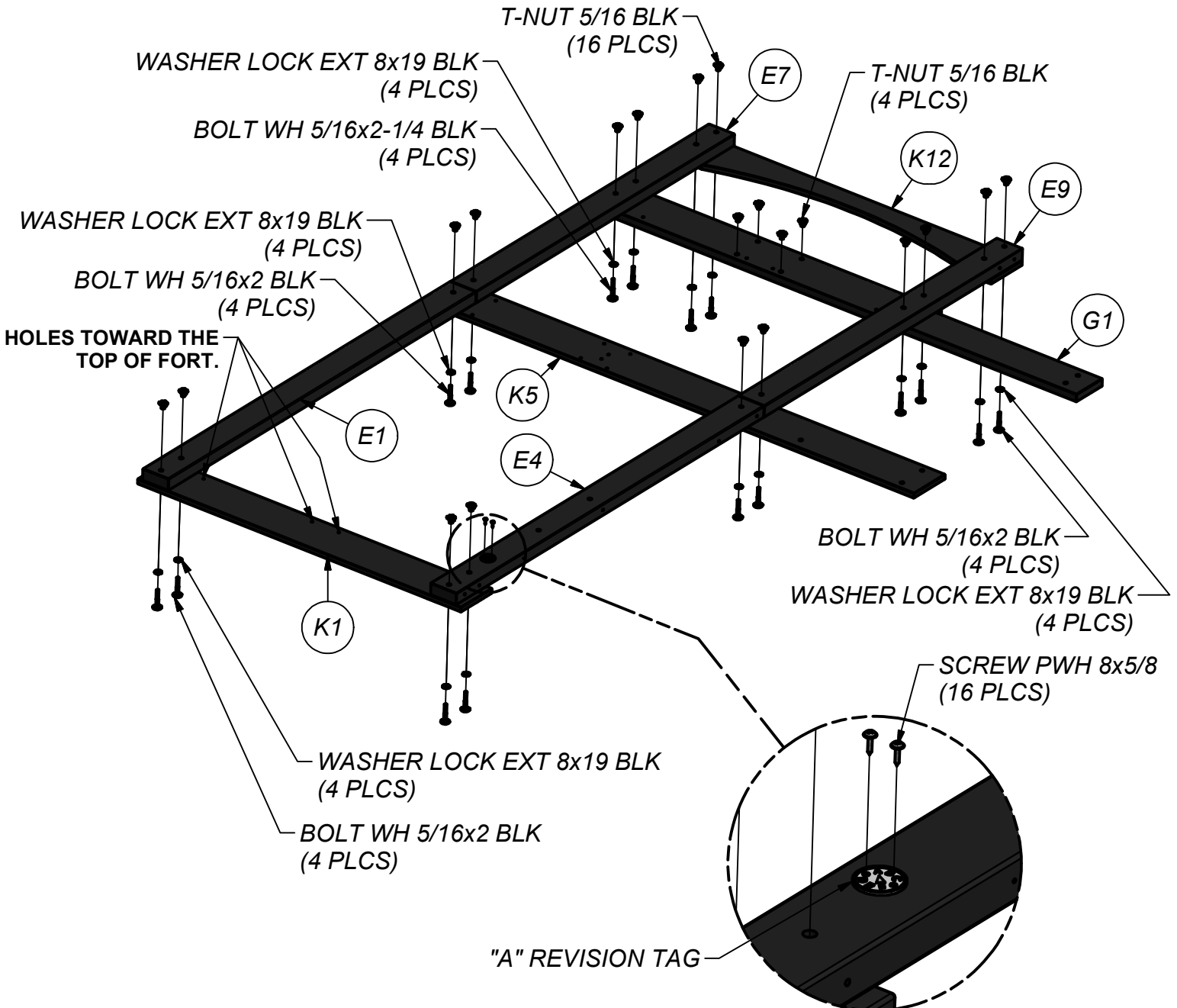
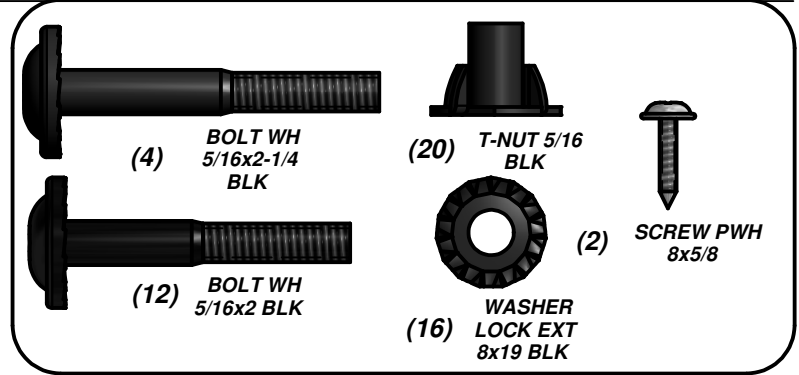

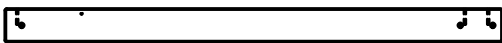

(1) **E2 - LEFT REAR UPRIGHT - W4L07493**  
1 3/8"x3 3/8"x51 3/4" (36x86x1314)

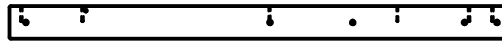

(1) **E3 - LEFT FRONT UPRIGHT - W4L07494**  
1 3/8"x3 3/8"x51 3/4" (36x86x1314)



(1) **E6 - LEFT REAR UPRIGHT - W4L07509**  
1 3/8"x3 3/8"x43 1/2" (36x86x1104)



(1) **E8 - LEFT FRONT UPRIGHT - W4L07511**  
1 3/8"x3 3/8"x43 1/2" (36x86x1104)



(1) **K2 - GROUND BOARD - W4L07490**  
5/8"x5 1/4"x41 7/8" (16x134x1064)



(1) **K8 - LEFT CENTER WALL RAIL - W4L07499**  
5/8"x5 1/4"x40 5/8" (16x134x1032)



(1) **K13 - ARCHED WALL RAIL - W4L07580**  
5/8"x5 1/4"x40 5/8" (16x134x1032)

## STEP 2

**INSTALL T-NUTS INTO PARTS BEFORE ASSEMBLY OF PARTS.**

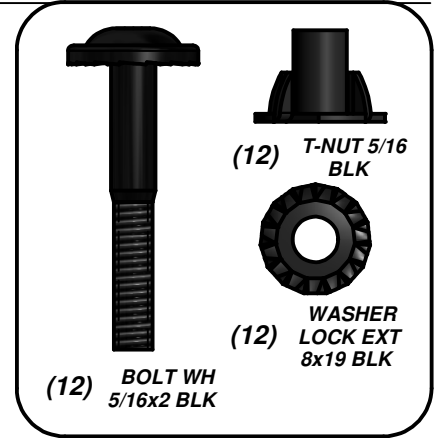

(12) **T-NUT 5/16 BLK**

(12) **WASHER LOCK EXT 8x19 BLK**

(12) **BOLT WH 5/16x2 BLK**

**T-NUT 5/16 BLK (12 PLCS)**

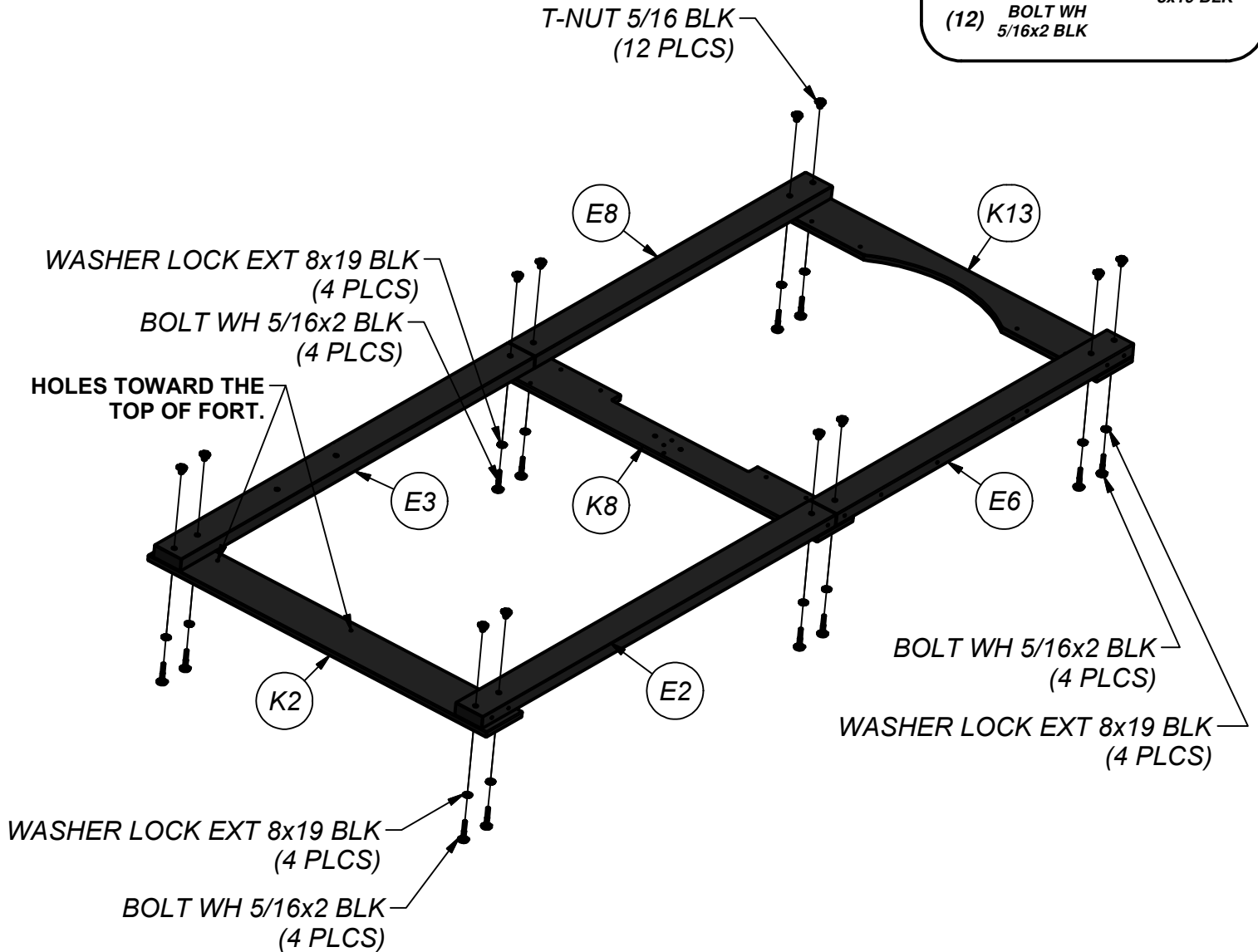

(1) **J1 - PORCH GROUND BOARD - W4L07504**  
1"x2 3/8"x40 1/2" (24x60x1030)

(1) **K4 - GROUND BOARD - W4L07492**  
5/8"x5 1/4"x40 1/2" (16x134x1030)

(1) **M1 - WALL RAIL - W4L07590**  
5/8"x3 3/8"x40 1/2" (16x86x1030)

(1) **K6 - FRONT CENTER WALL RAIL - W4L07497**  
5/8"x5 1/4"x61 3/8" (16x134x1560)

(1) **K15 - ANGLED WALL RAIL - W4L07582**  
5/8"x5 1/4"x45 3/4" (16x134x1162)

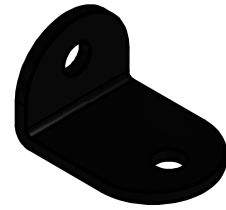

(1) - **L BRACKET BLACK 32x51 - A4M00710**

**STEP 3**

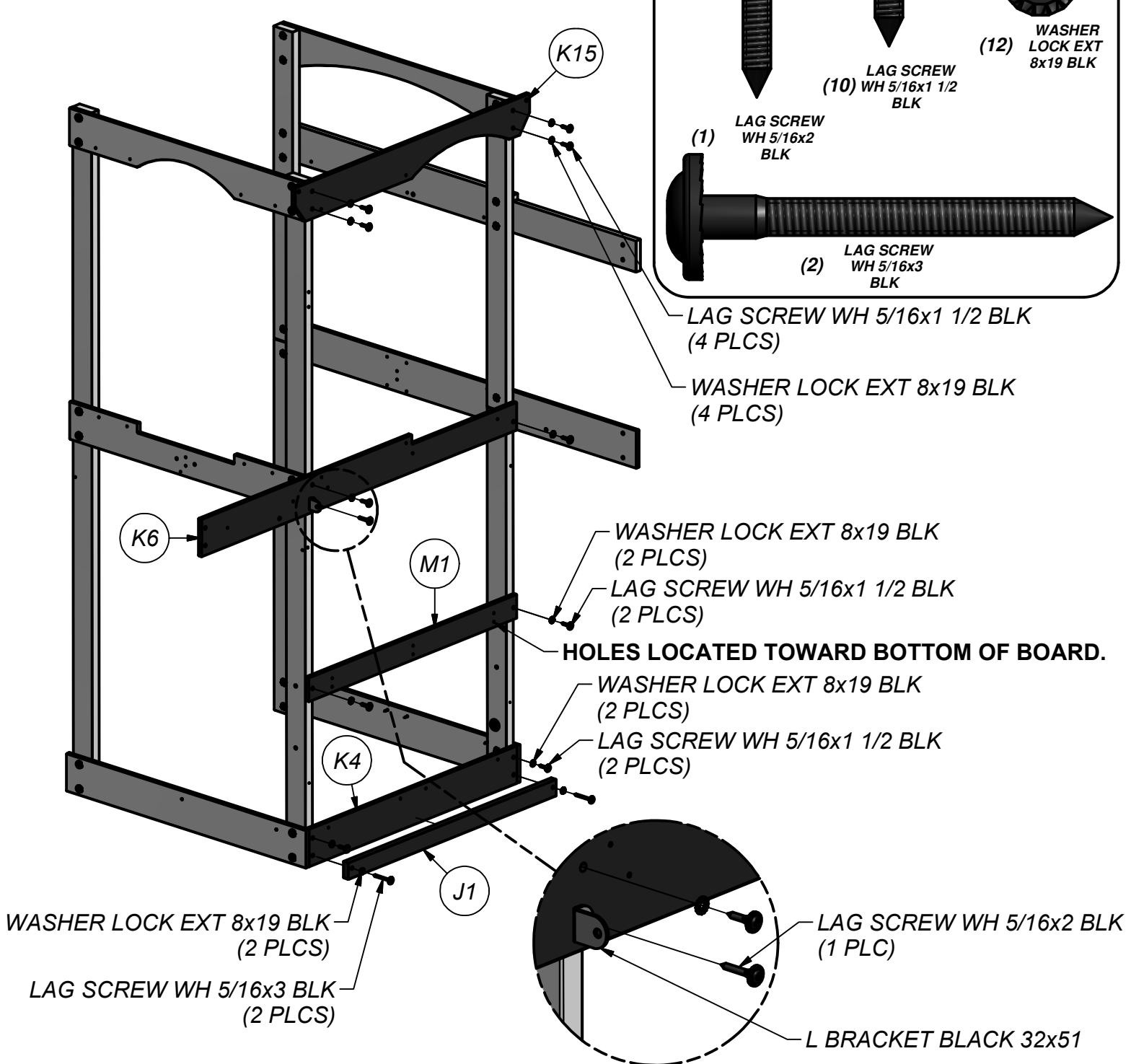

(1) **K3 - GROUND BOARD - W4L07491**  
5/8"x5 1/4"x40 1/2" (16x134x1030)

(1) **K7 - REAR CENTER WALL RAIL - W4L07498**  
5/8"x5 1/4"x61 3/8" (16x134x1560)

(1) **K14 - ANGLED WALL RAIL - W4L07581**  
5/8"x5 1/4"x45 3/4" (16x134x1162)

**STEP 4**

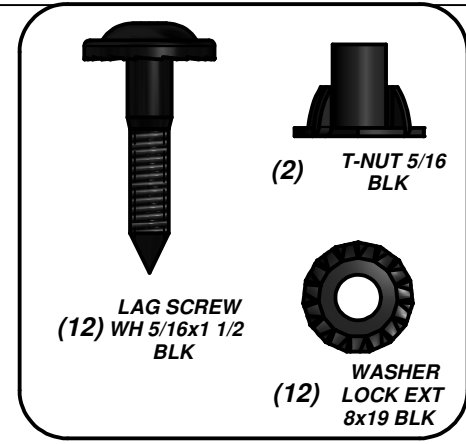
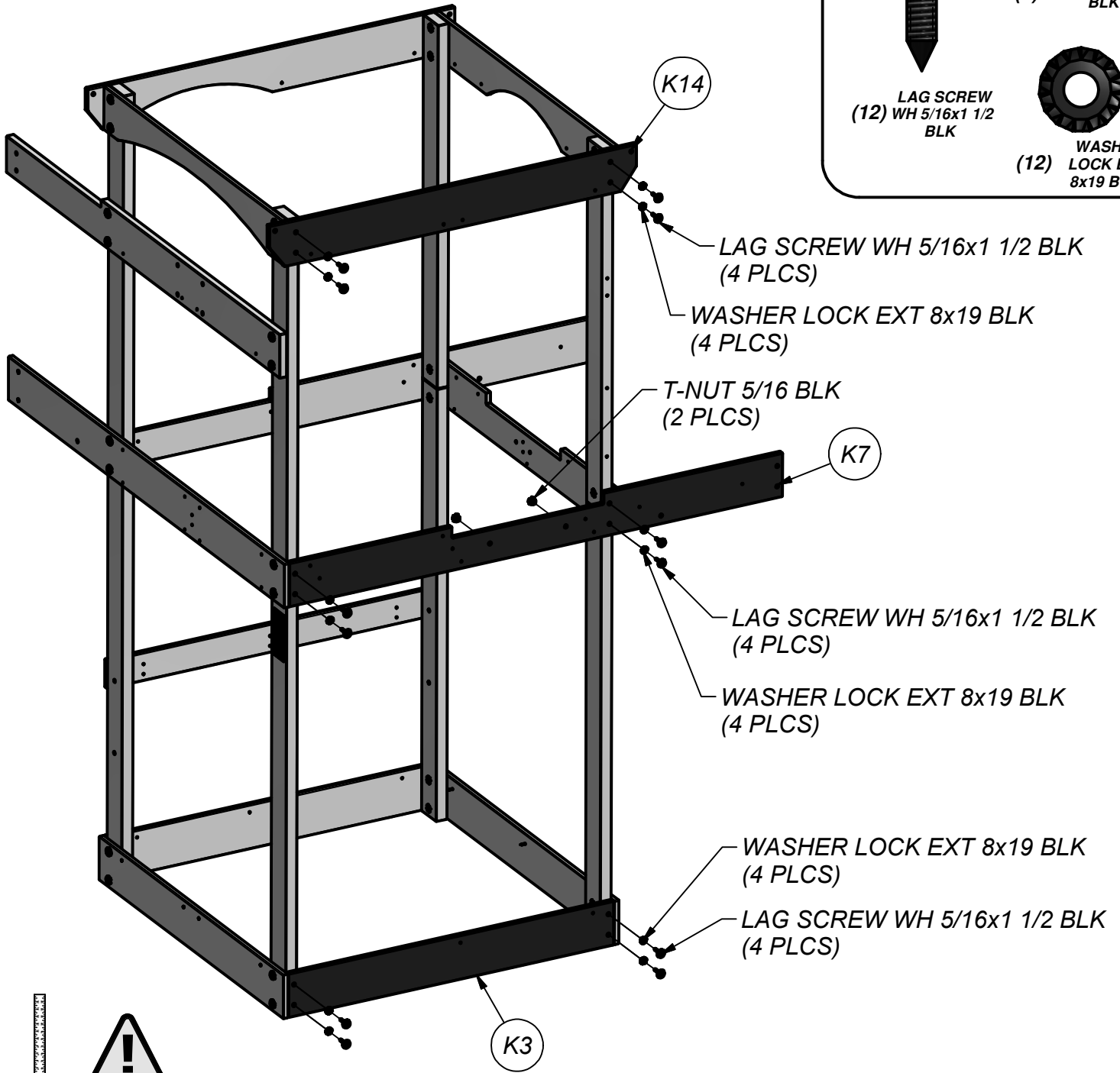



(1) L2 - WALL RAIL - W4L07515  
5/8"x4 3/8"x22 7/8" (16x112x582)

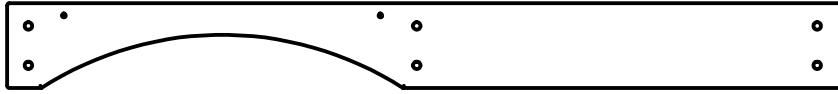

(1) L4 - ARCHED WALL RAIL - W4L07577  
5/8"x4 3/8"x43 1/2" (16x112x1106)

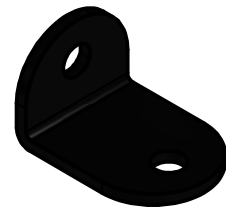

(1) - L BRACKET BLACK 32x51 - A4M00710

**STEP 5**

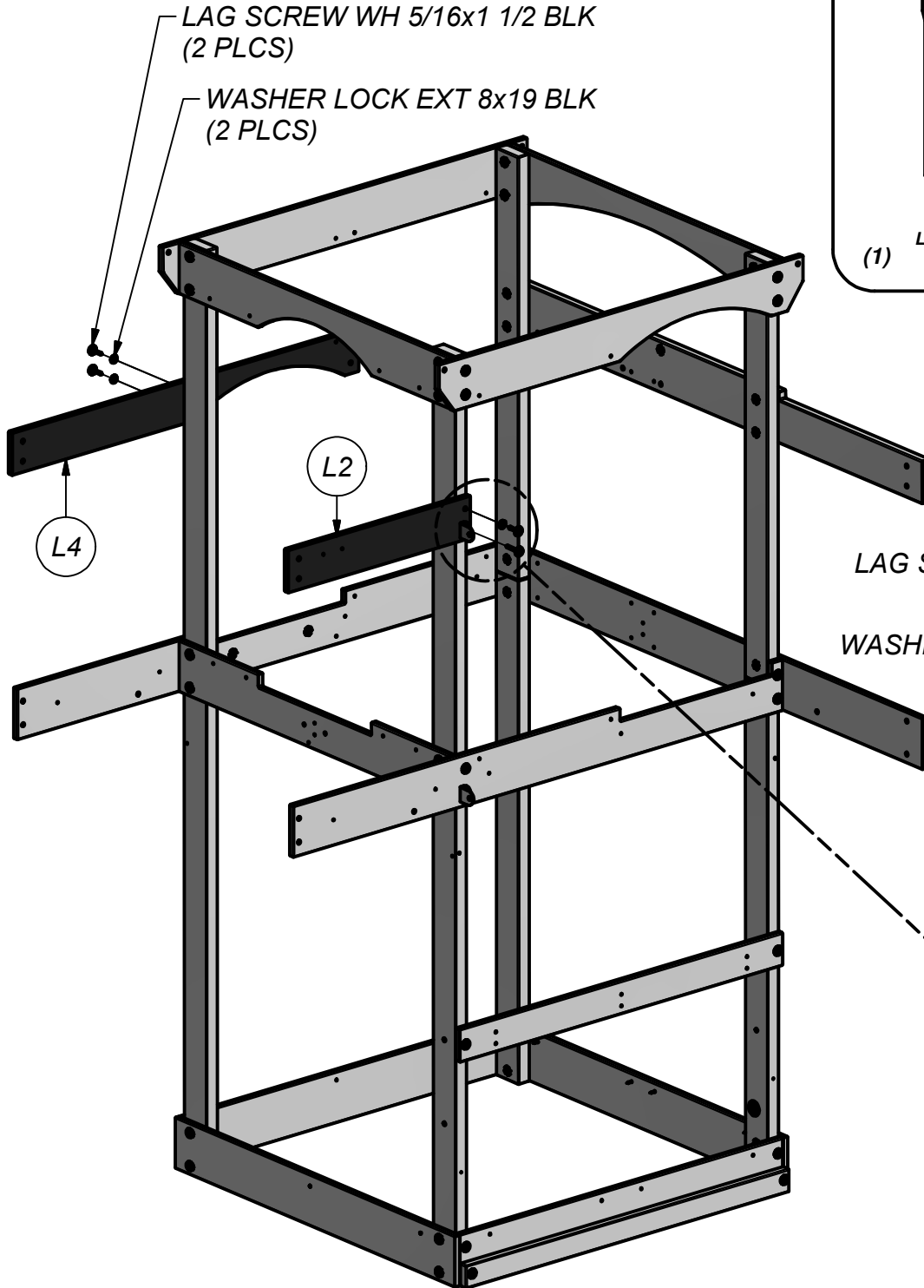

LAG SCREW WH 5/16x1 1/2 BLK  
(2 PLCS)

WASHER LOCK EXT 8x19 BLK  
(2 PLCS)

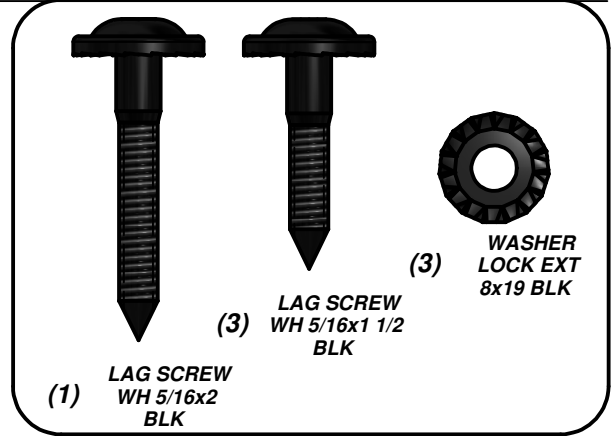

(1) LAG SCREW  
WH 5/16x2  
BLK

(3) LAG SCREW  
WH 5/16x1 1/2  
BLK

(3) WASHER  
LOCK EXT  
8x19 BLK

LAG SCREW WH 5/16x1 1/2 BLK  
(1 PLC)

WASHER LOCK EXT 8x19 BLK  
(1 PLC)

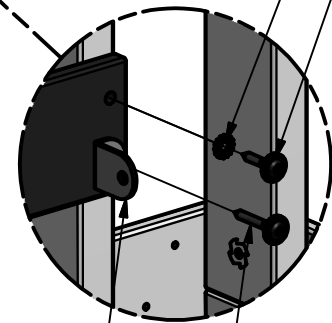

L BRACKET BLACK 32x51

LAG SCREW WH 5/16x2 BLK  
(1 PLC)



(1) **F1 - RIGHT BALCONY UPRIGHT - W4L07506**  
1 3/8"x2 3/8"x31 3/4" (36x60x805)



(1) **F2 - LEFT BALCONY UPRIGHT - W4L07507**  
1 3/8"x2 3/8"x31 3/4" (36x60x805)

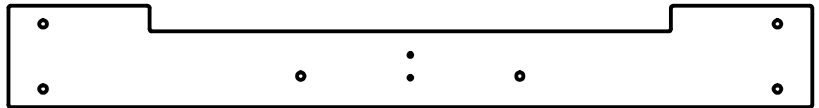

(1) **K11 - LEFT SIDE WALL BOARD - W4L07508**  
5/8"x5 1/4"x41 7/8" (16x134x1064)



(1) **L5 - ARCHED WALL RAIL - W4L07578**  
5/8"x4 3/8"x40 5/8" (16x112x1032)

**STEP 6**  
**INSTALL T-NUTS INTO PARTS BEFORE**  
**ASSEMBLY OF PARTS.**

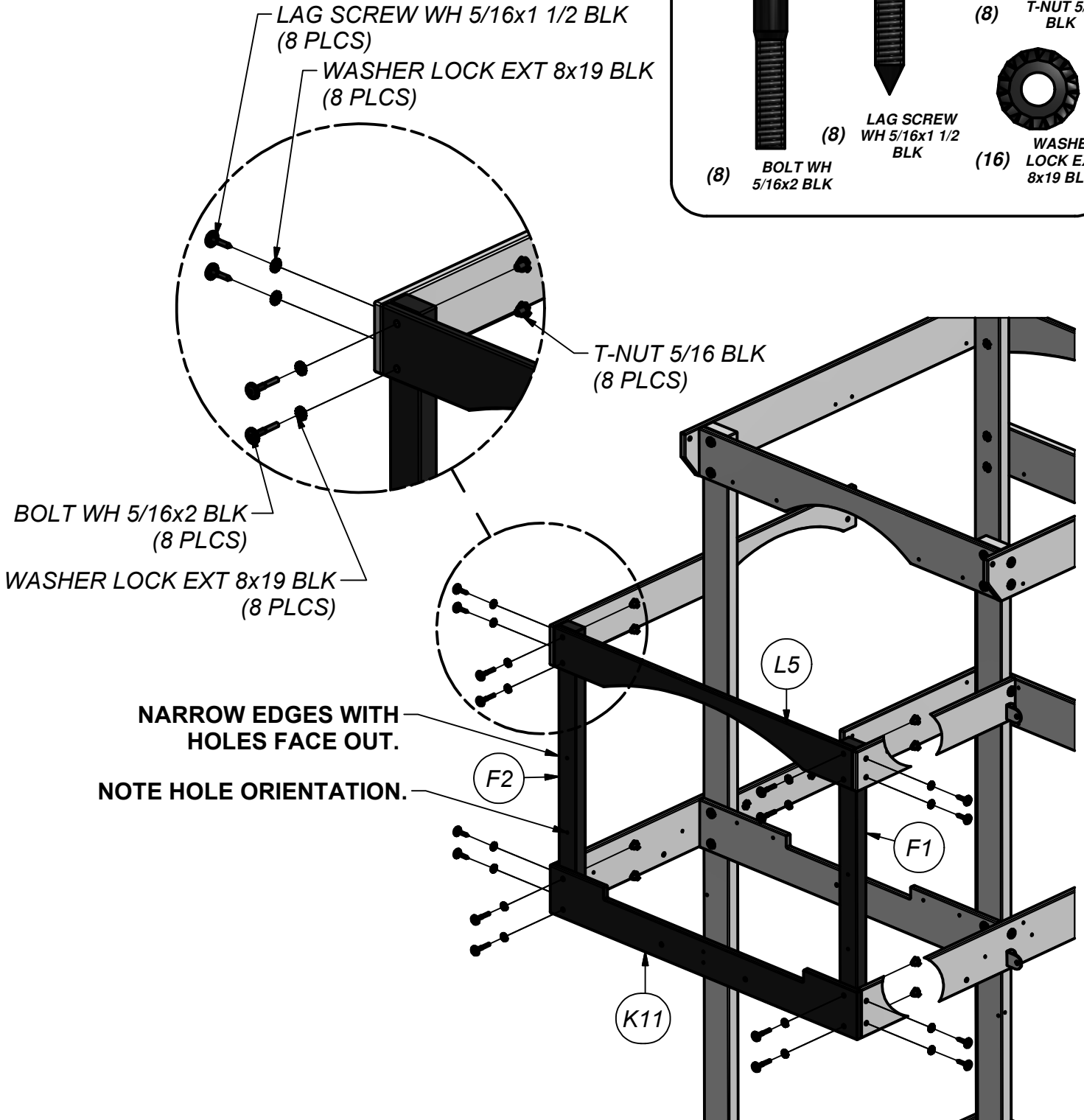
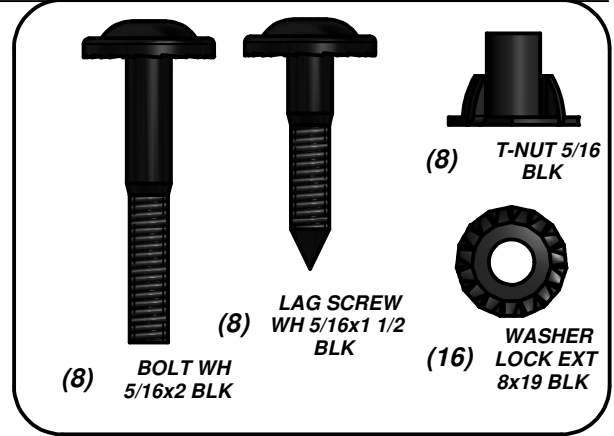



(2) **H4 - DECK BRACE - W4L07616**  
 1"x3 3/8"x12 3/4" (24x86x325)

**STEP 7**  
**INSTALL T-NUTS INTO PARTS BEFORE ASSEMBLY OF PARTS.**

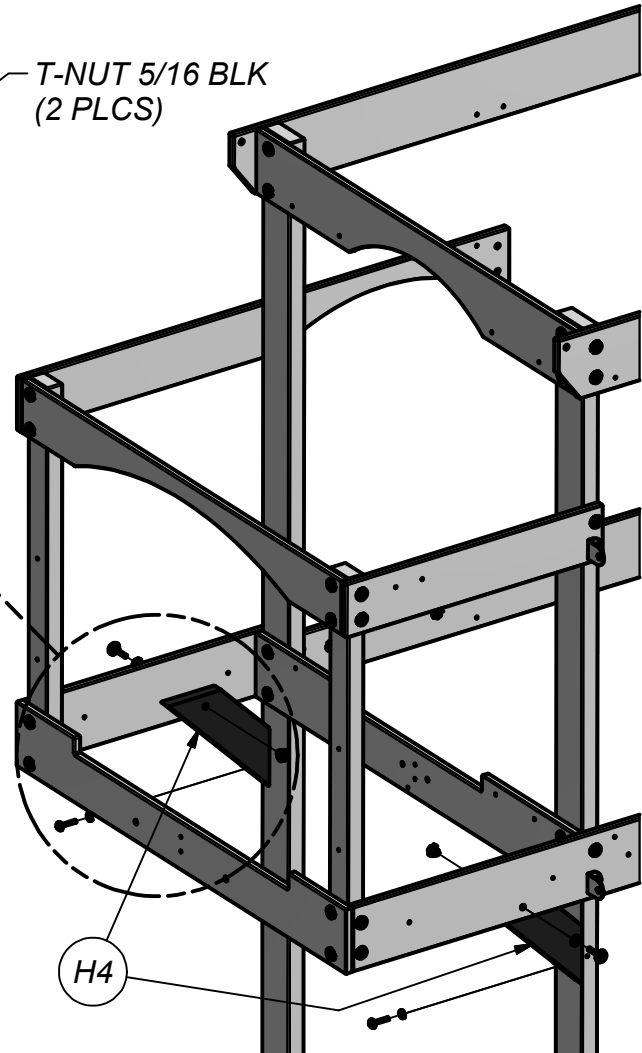
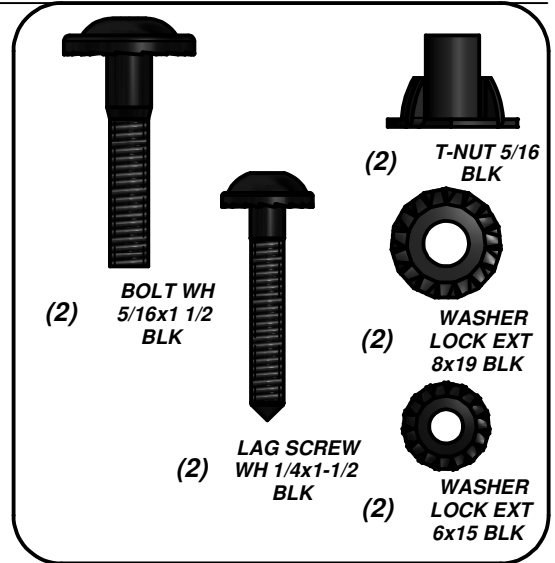
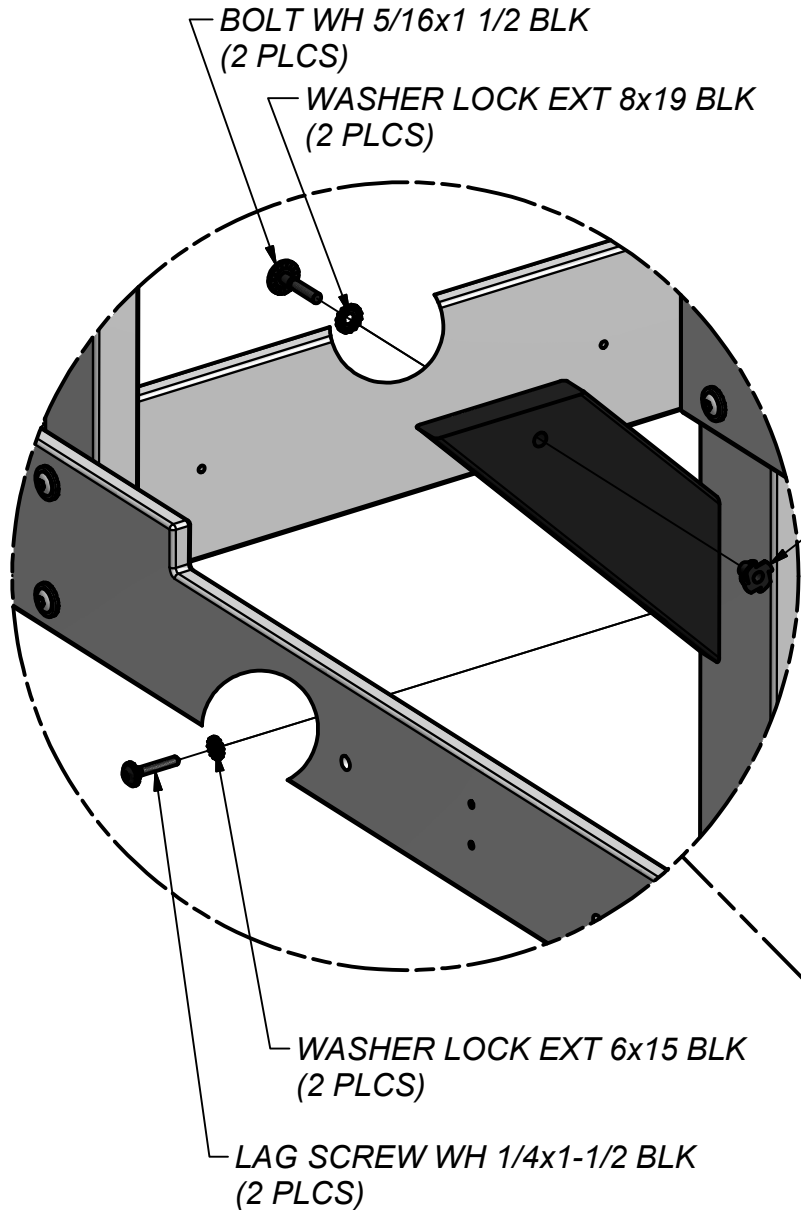



(1) **K9 - LEFT BALCONY WALL RAIL - W4L07500**  
5/8"x5 1/4"x20 3/4" (16x134x528)

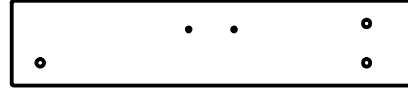

(1) **L3 - WALL RAIL - W4L07576**  
5/8"x4 3/8"x20 7/8" (16x112x529)

**STEP 8**

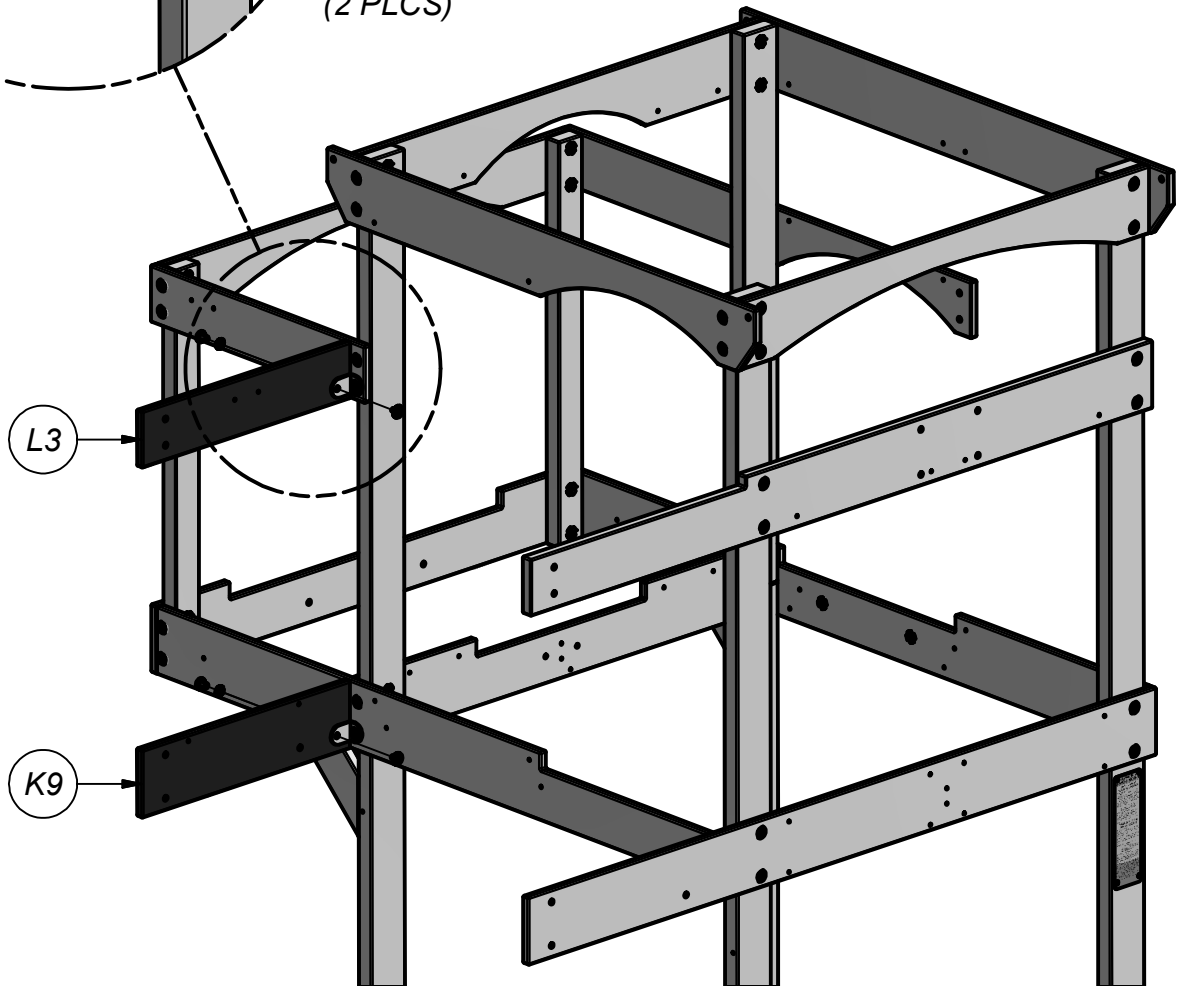
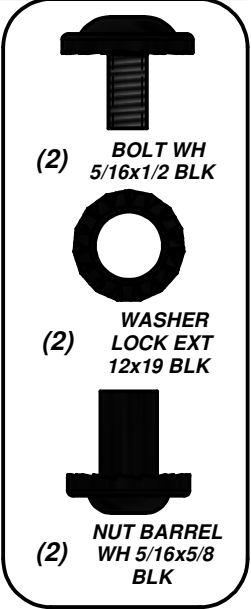
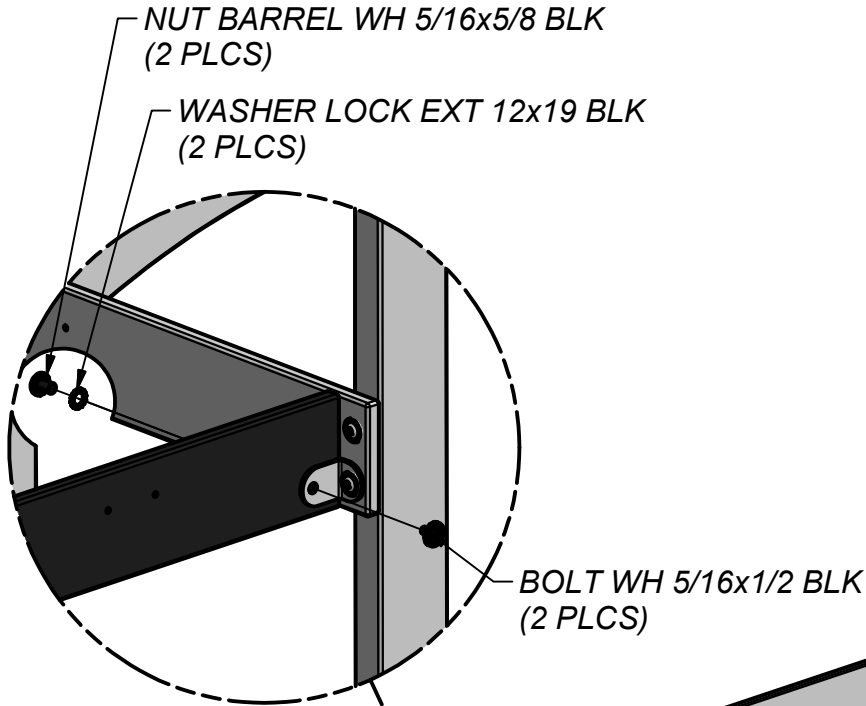

(1) E5 - RIGHT FRONT BALCONY UPRIGHT - W4L07502  
1 3/8"x3 3/8"x80 3/4" (36x86x2052)

(1) E11 - RIGHT FRONT BALCONY UPRIGHT - W4L07673  
1 3/8"x3 3/8"x80 3/4" (36x86x2052)

(2) N1 - PORCH GROUND BOARD - W4L07503  
5/8"x2 3/8"x21 1/8" (16x60x537)

**STEP 9**

**INSTALL T-NUTS INTO PARTS BEFORE ASSEMBLY OF PARTS.**

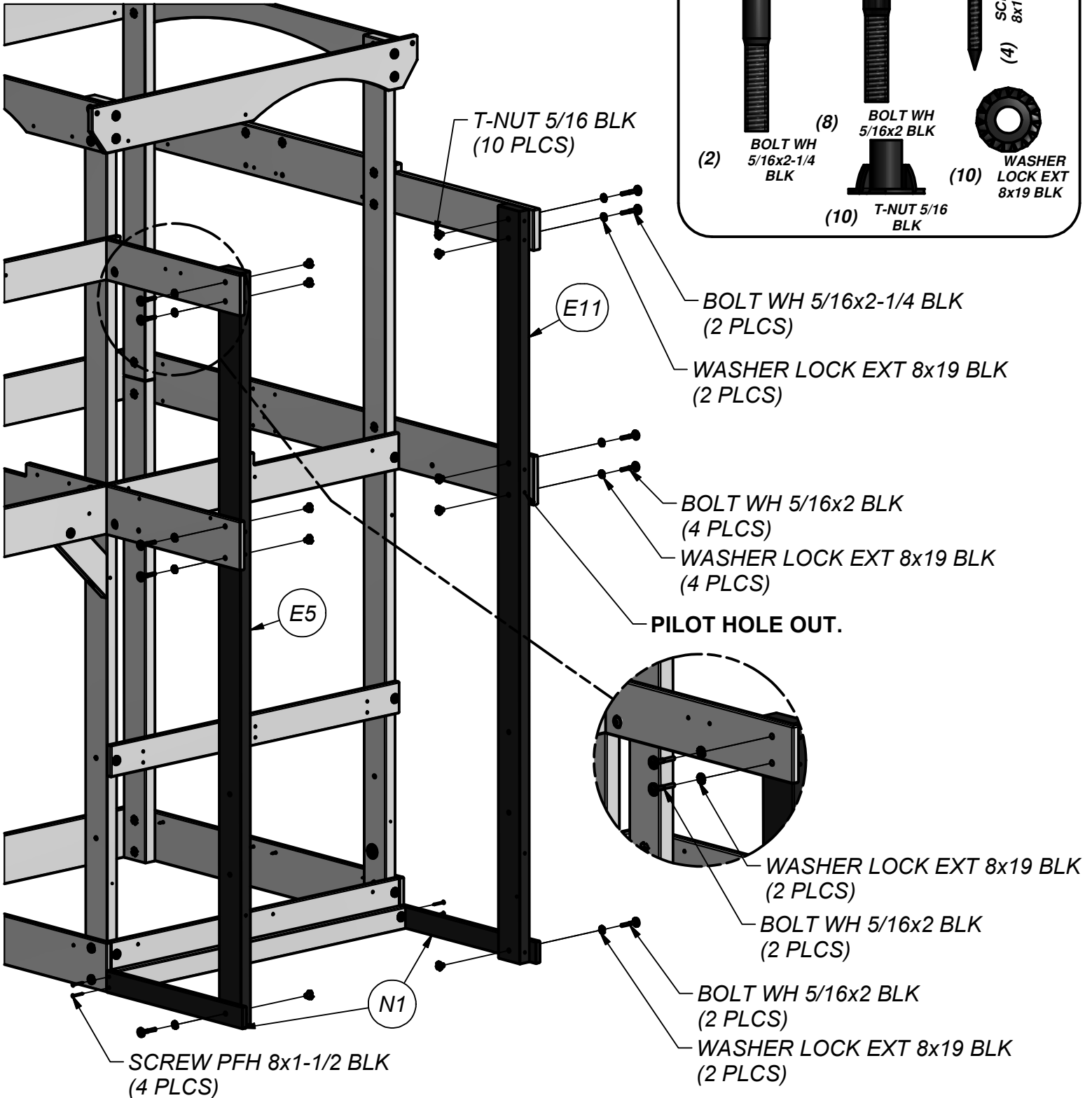



(1) **J2 - PORCH GROUND BOARD - W4L07505**  
1"x2 3/8"x40 5/8" (24x60x1032)



(1) **L1 - ARCHED WALL RAIL - W4L07514**  
5/8"x4 3/8"x40 5/8" (16x112x1032)

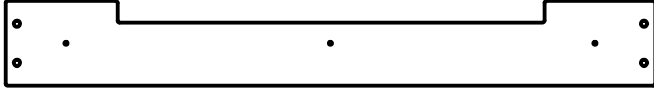

(1) **K10 - FRONT BALCONY WALL RAIL - W4L07501**  
5/8"x5 1/4"x40 5/8" (16x134x1032)

**STEP 10**

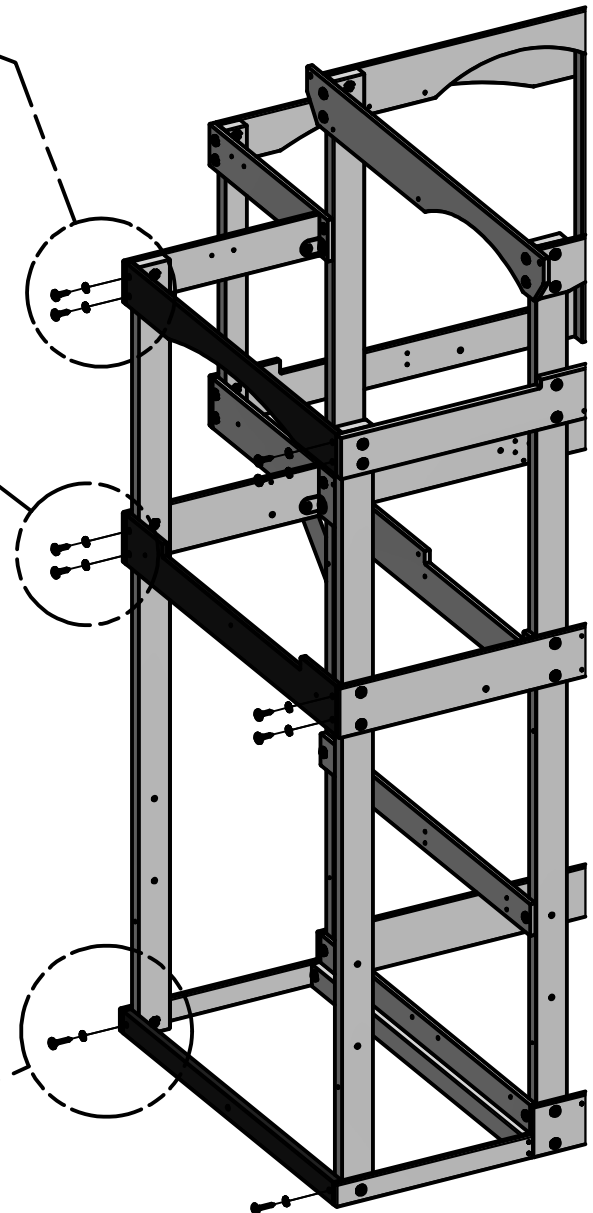
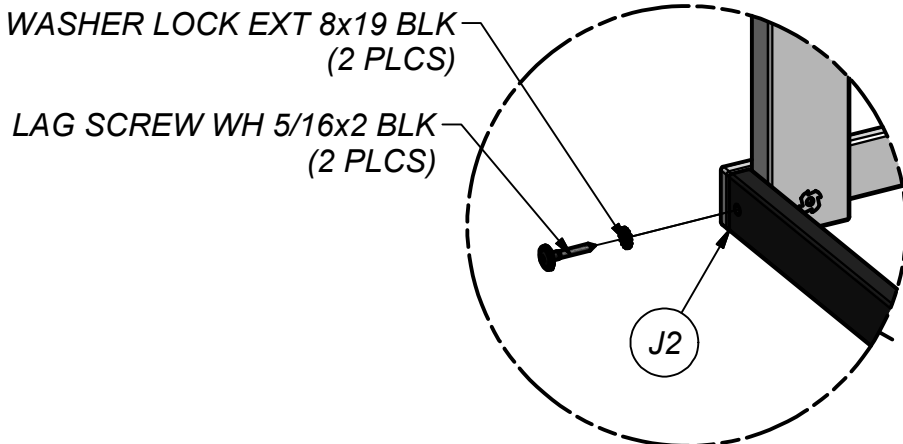
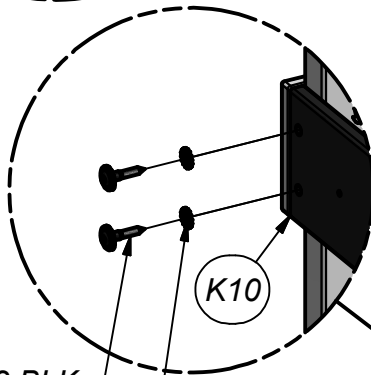
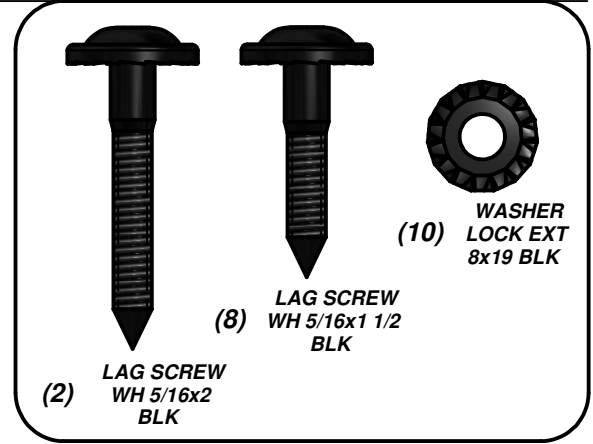
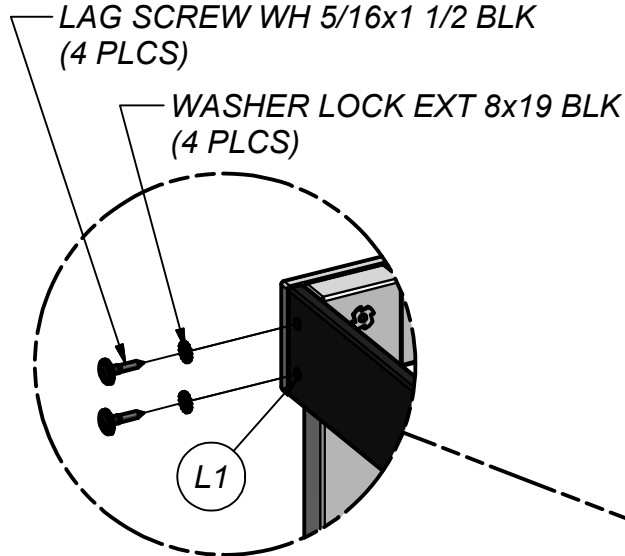



(2) **H4 - DECK BRACE - W4L07616**  
 1"x3 3/8"x12 3/4" (24x86x325)

**STEP 11**  
**INSTALL T-NUTS INTO PARTS BEFORE ASSEMBLY OF**  
**PARTS.**

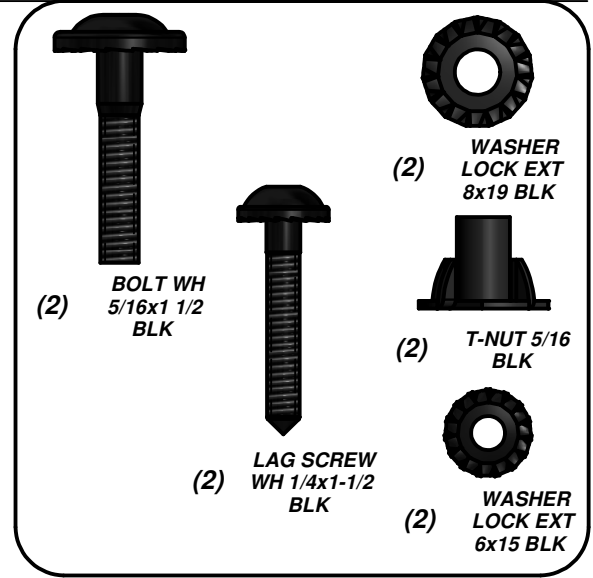
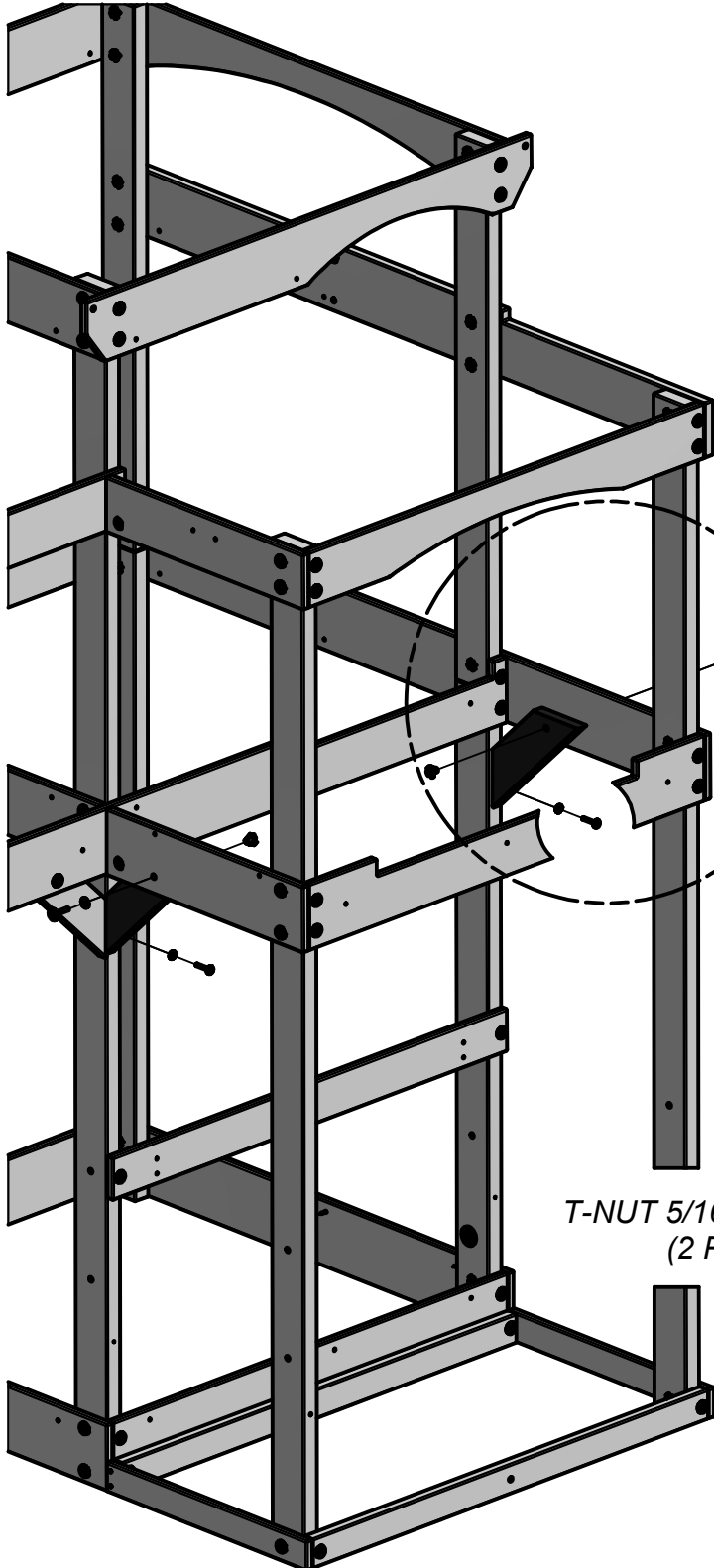

**BOLT WH 5/16x1 1/2 BLK**  
 (2 PLCS)

**WASHER LOCK EXT 8x19 BLK**  
 (2 PLCS)

**T-NUT 5/16 BLK**  
 (2 PLCS)

**WASHER LOCK EXT 6x15 BLK**  
 (2 PLCS)

**LAG SCREW WH 1/4x1-1/2 BLK**  
 (2 PLCS)



(1) J8 - FLOOR JOIST - W4L07602  
1"x2 3/8"x40 1/2" (24x60x1029)

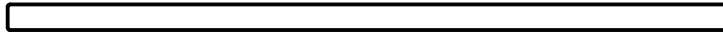

(2) T1 - SUPPORT BOARD - W4L07599  
1"x1 3/8"x37 5/8" (24x34x957)

**STEP 12**

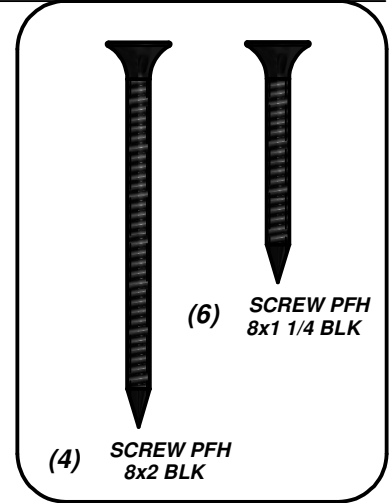
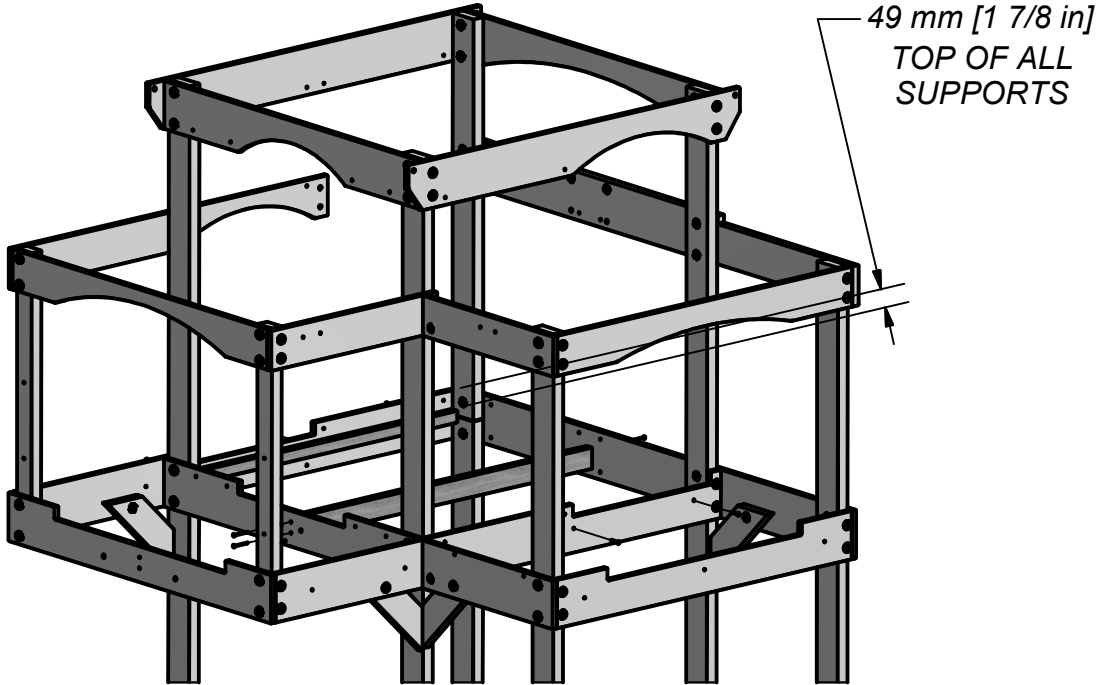

SCREW PFH 8x1 1/4 BLK  
(3 PLCS)

SCREW PFH 8x2 BLK  
(2 PLCS)

SCREW PFH 8x2 BLK  
(2 PLCS)

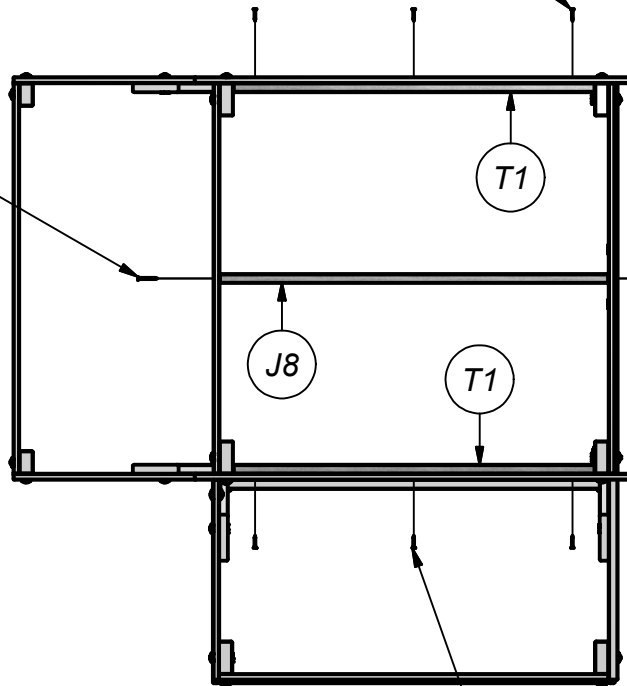

TOP VIEW

SCREW PFH 8x1 1/4 BLK  
(3 PLCS)



(1) J9 - FLOOR JOIST - W4L07603  
1"x2 3/8"x20 1/4" (24x60x513)



(2) T3 - SUPPORT BOARD - W4L07601  
1"x1 3/8"x18 3/4" (24x34x477)

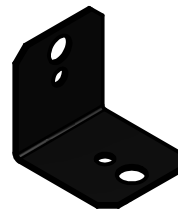

(2) - 90° L-BRACKET - BLK - A4M00555

**STEP 13**

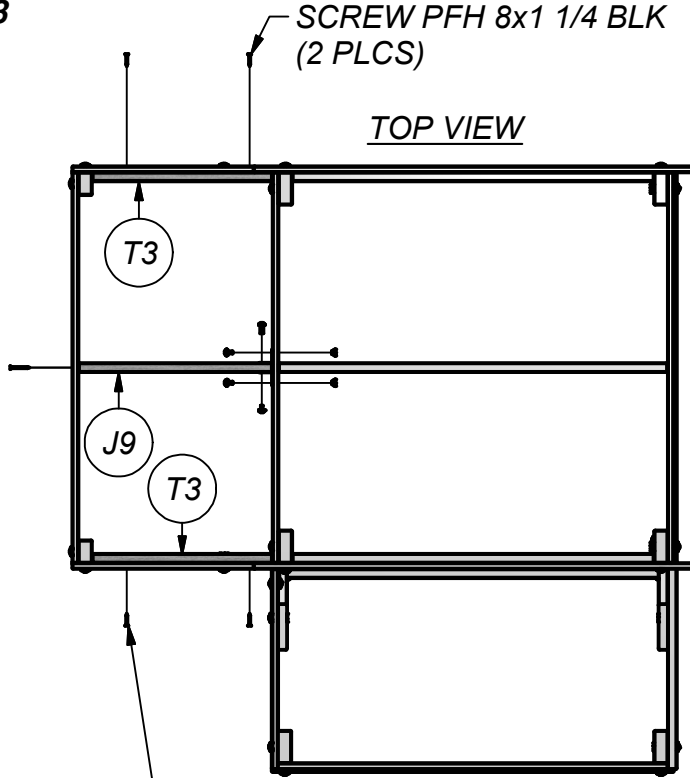

SCREW PFH 8x1 1/4 BLK  
(2 PLCS)

TOP VIEW

T3

J9

T3

SCREW PFH 8x1 1/4 BLK  
(2 PLCS)

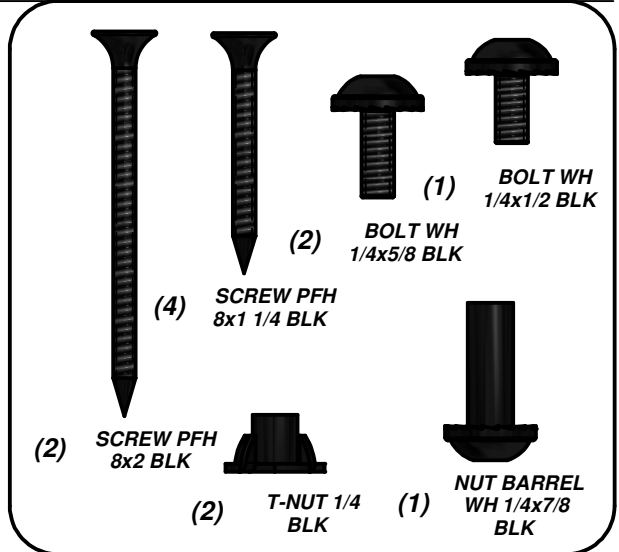

(4) SCREW PFH  
8x1 1/4 BLK

(2) BOLT WH  
1/4x5/8 BLK

(1) BOLT WH  
1/4x1/2 BLK

(2) SCREW PFH  
8x2 BLK

(2) T-NUT 1/4  
BLK

(1) NUT BARREL  
WH 1/4x7/8  
BLK

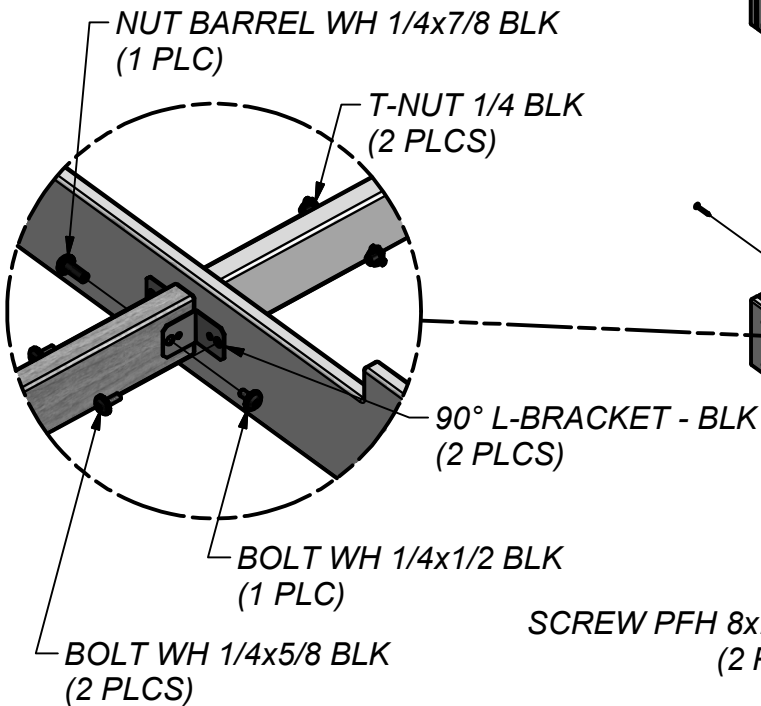

NUT BARREL WH 1/4x7/8 BLK  
(1 PLC)

T-NUT 1/4 BLK  
(2 PLCS)

90° L-BRACKET - BLK  
(2 PLCS)

BOLT WH 1/4x1/2 BLK  
(1 PLC)

BOLT WH 1/4x5/8 BLK  
(2 PLCS)

SCREW PFH 8x2 BLK  
(2 PLCS)

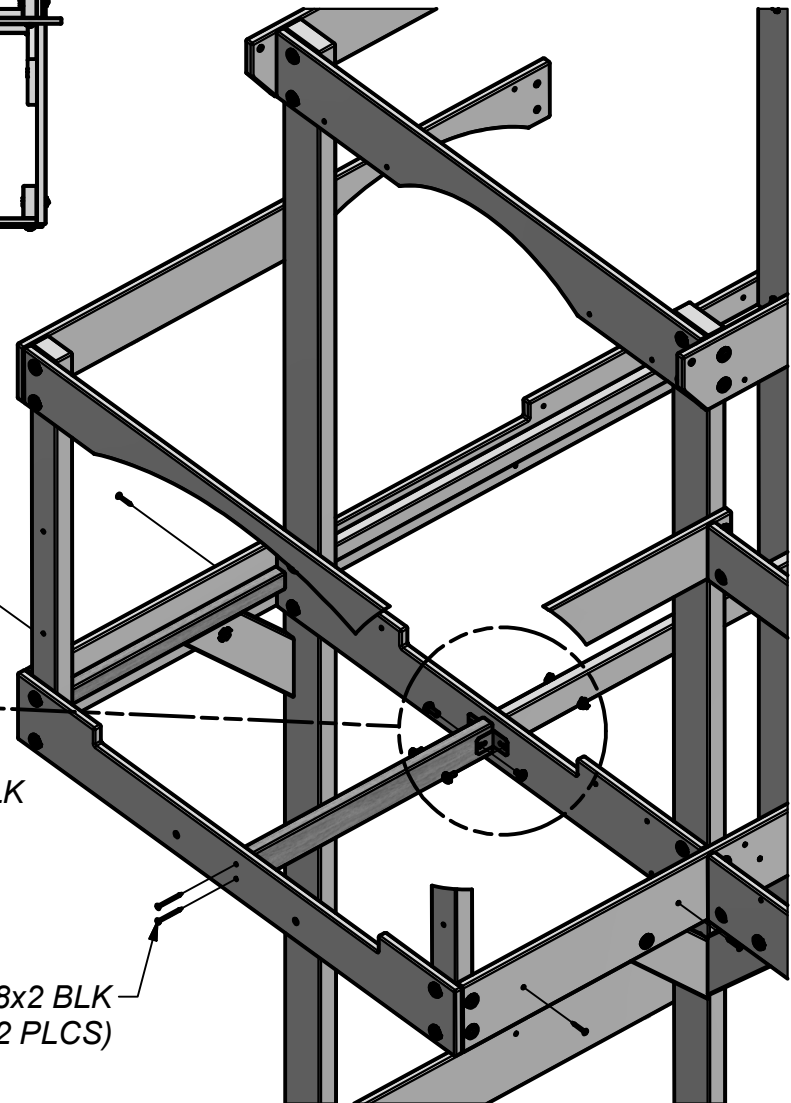

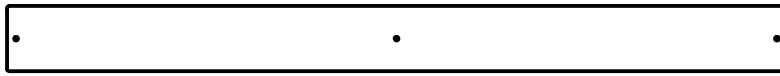

(10) **M11 - FLOOR BOARD - W4L07610**  
5/8"x3 3/8"x40 5/8" (16x86x1031)

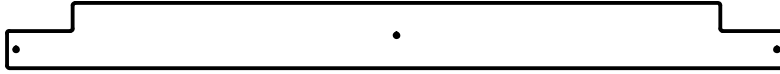

(2) **M12 - FLOOR BOARD - W4L07611**  
5/8"x3 3/8"x40 5/8" (16x86x1031)

**STEP 14**

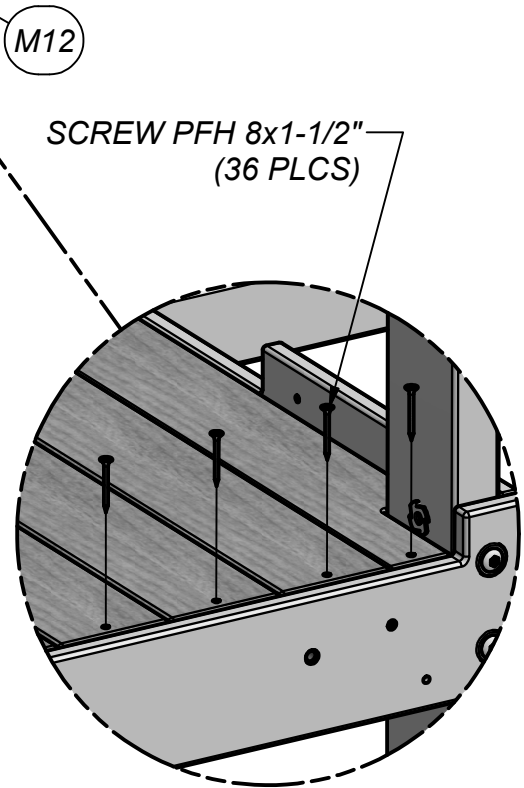
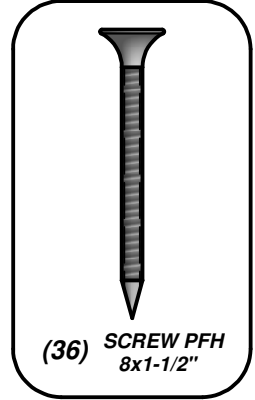
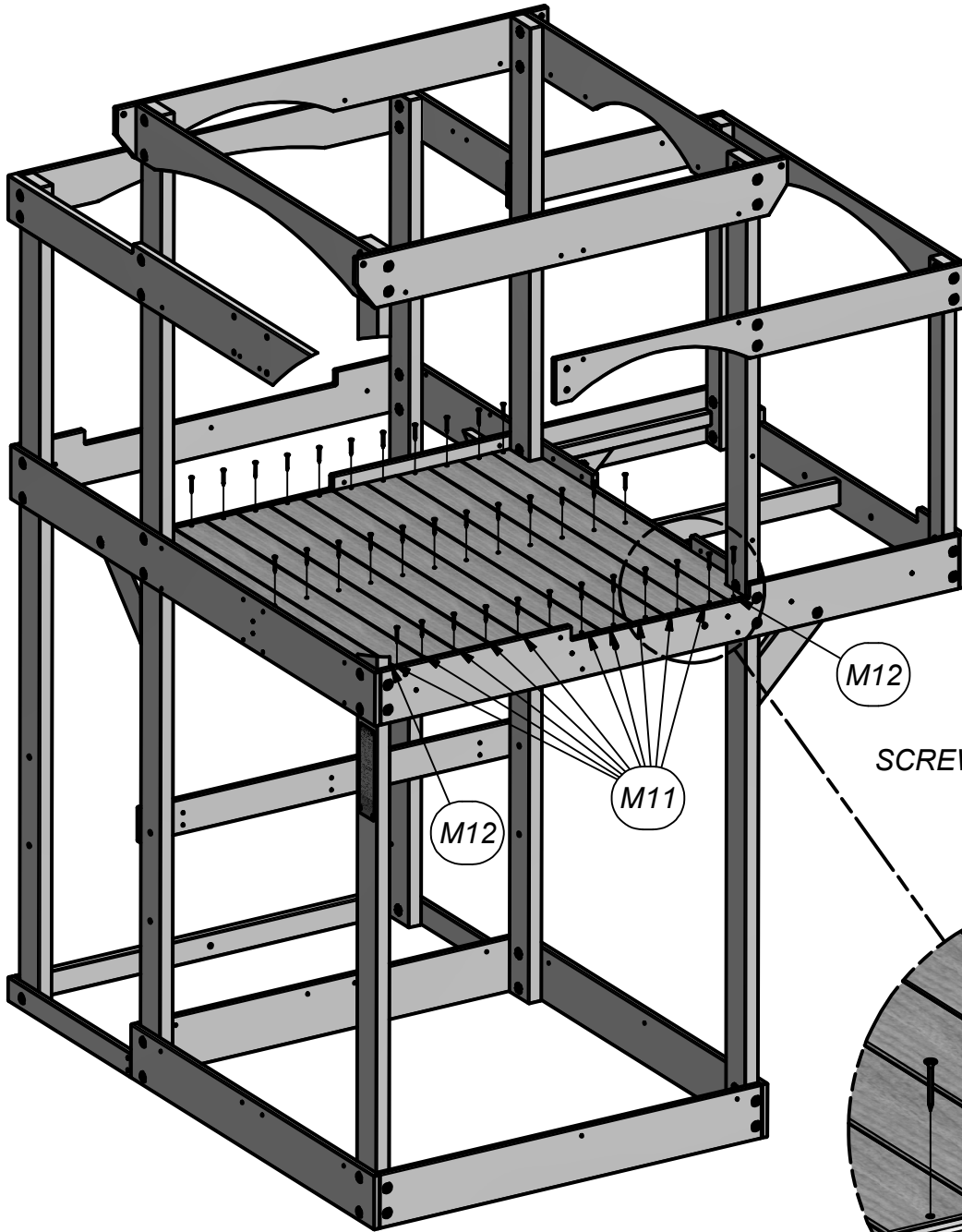

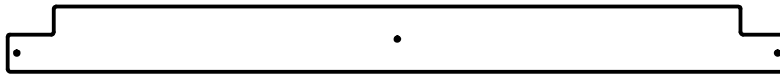

(1) M10 - FLOOR BOARD - W4L07609  
5/8"x3 3/8"x40 5/8" (16x86x1031)



(5) M11 - FLOOR BOARD - W4L07610  
5/8"x3 3/8"x40 5/8" (16x86x1031)

**STEP 15**

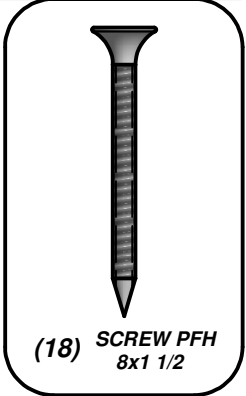
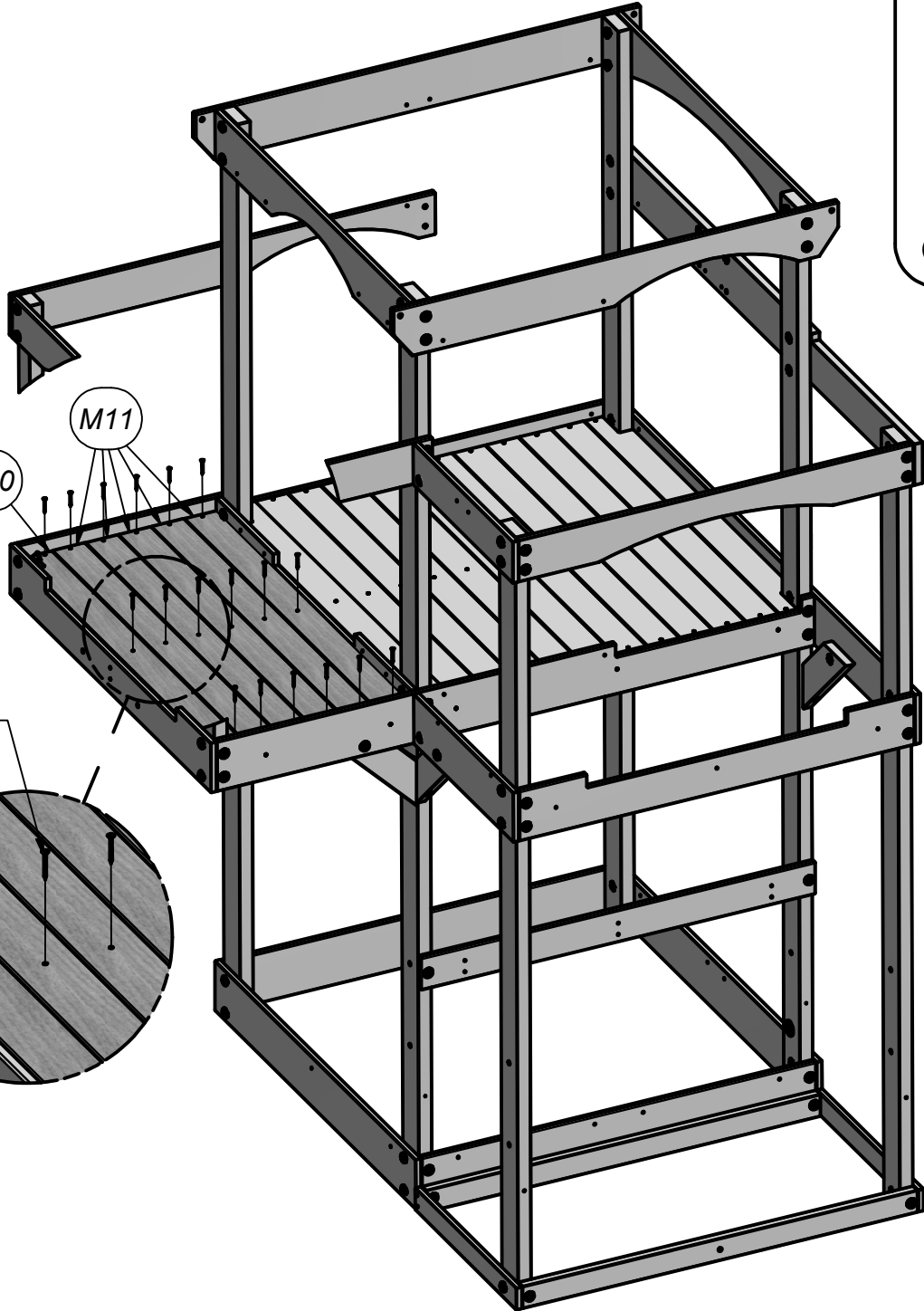

SCREW PFH 8x1 1/2  
(18 PLCS)

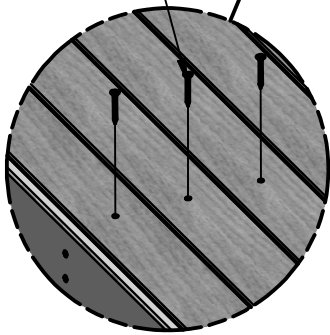

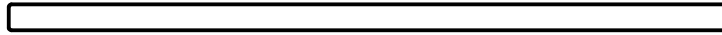

(1) T1 - SUPPORT BOARD - W4L07599  
1"x1 3/8"x37 5/8" (24x34x957)



(1) T2 - SUPPORT BOARD - W4L07600  
1"x1 3/8"x37 3/4" (24x34x959)

**STEP 16**

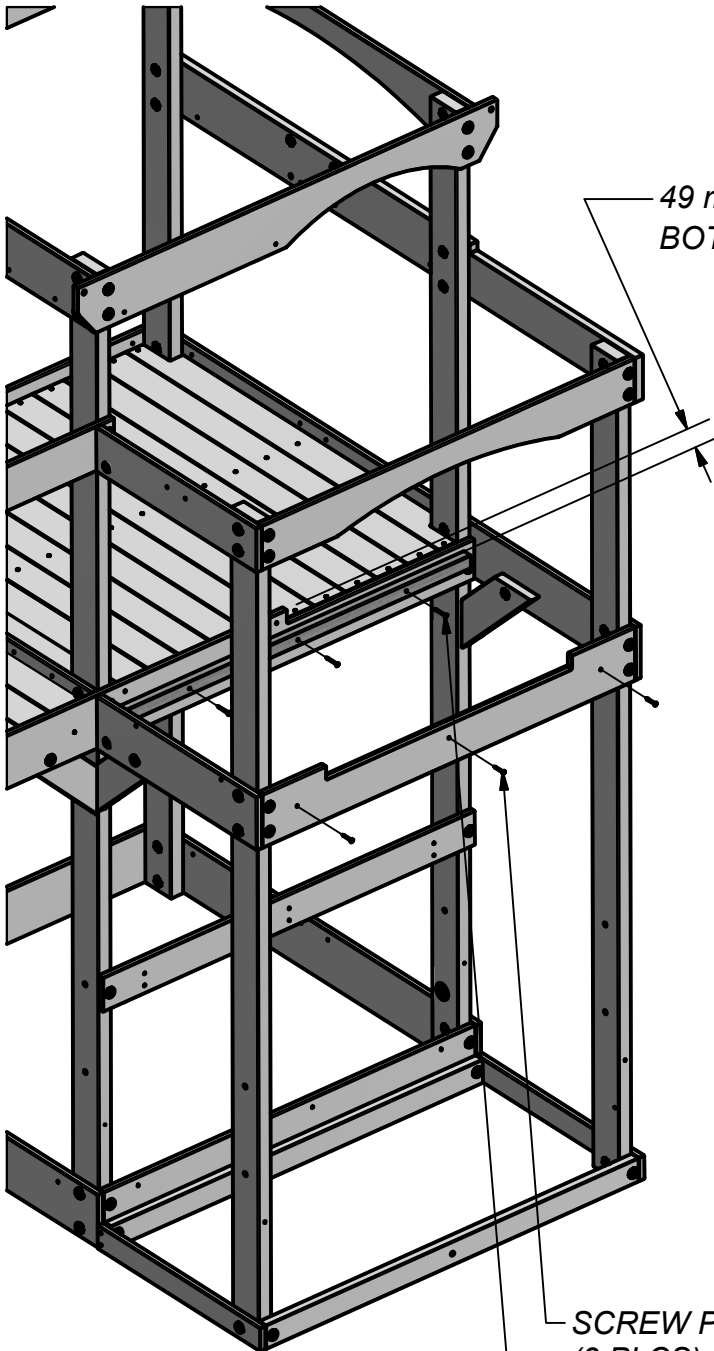

49 mm [1 7/8 in]  
BOTH SUPPORTS

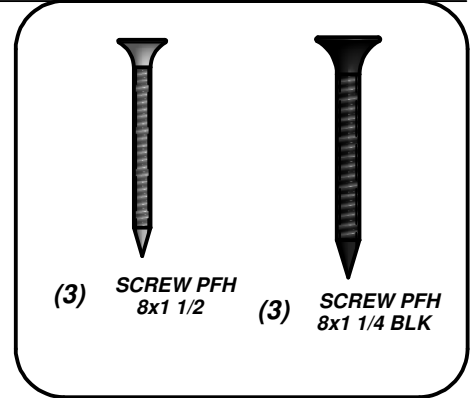

(3) SCREW PFH  
8x1 1/2

(3) SCREW PFH  
8x1 1/4 BLK

TOP VIEW

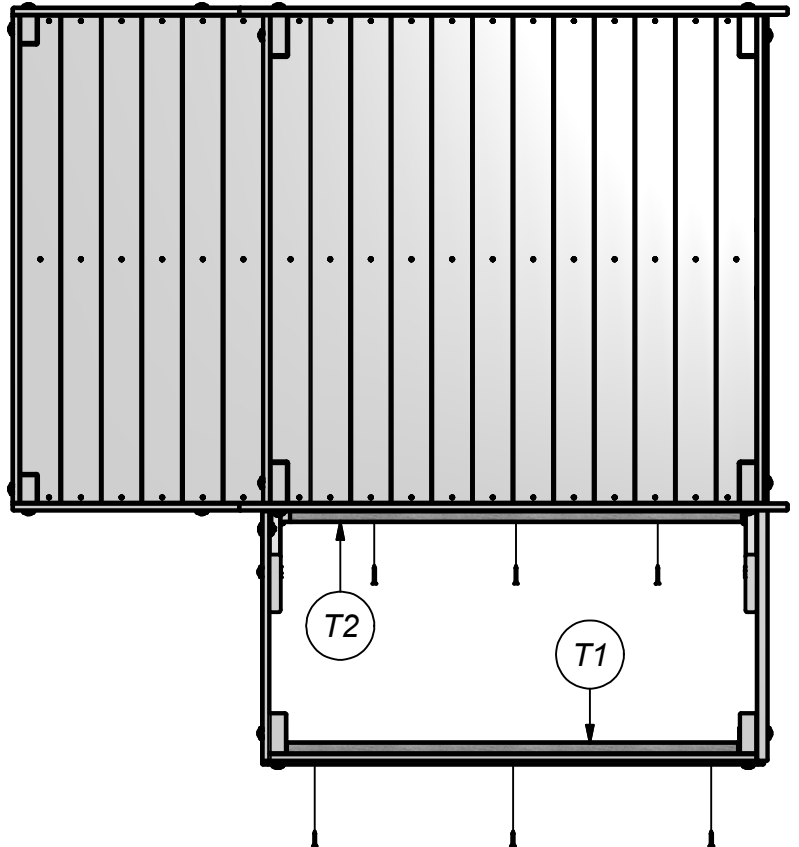

SCREW PFH 8x1 1/4 BLK  
(3 PLCS)

SCREW PFH 8x1 1/2  
(3 PLCS)



(1) **M8 - FLOOR BOARD - W4L07607**  
5/8"x3 3/8"x20 1/8" (16x86x512)



(10) **M9 - FLOOR BOARD - W4L07608**  
5/8"x3 3/8"x20 1/8" (16x86x512)



(1) **M13 - FLOOR BOARD - W4L07671**  
5/8"x3 3/8"x20 1/8" (16x86x512)

**STEP 17**

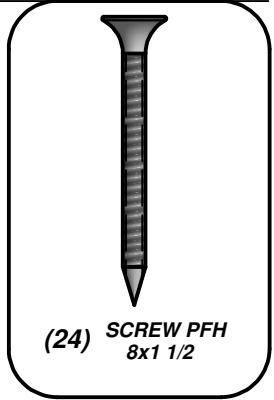
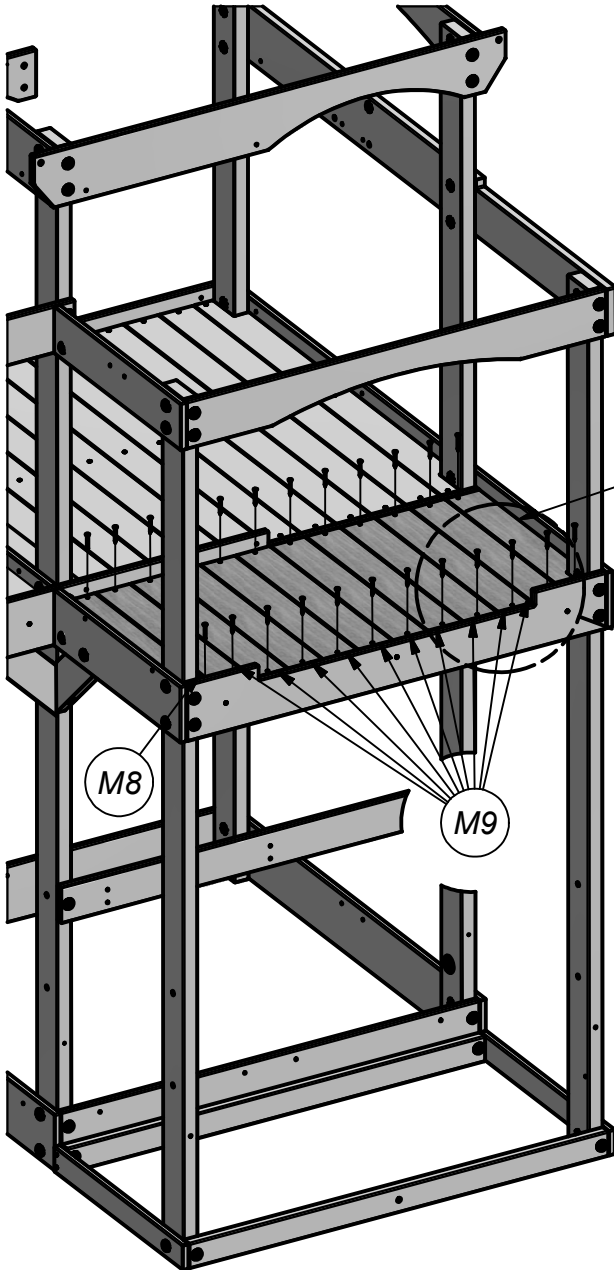

**SCREW PFH 8x1 1/2**  
(24 PLCS)

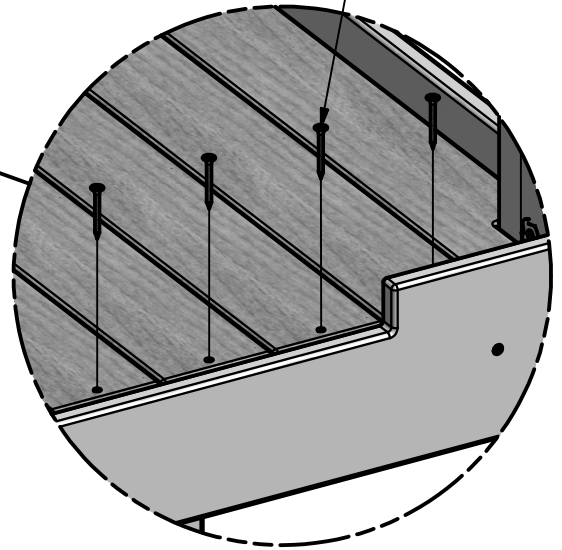

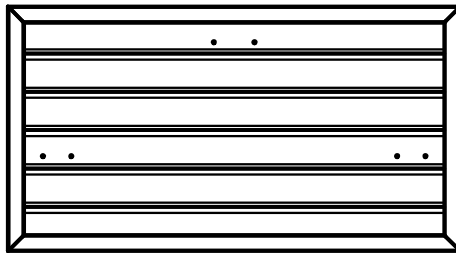

(1) WP1 - FRONT WALL PANEL - W2A02082  
1"x20 3/8"x37 3/4" (24x517x958)

STEP 18

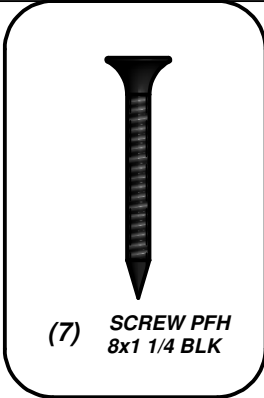
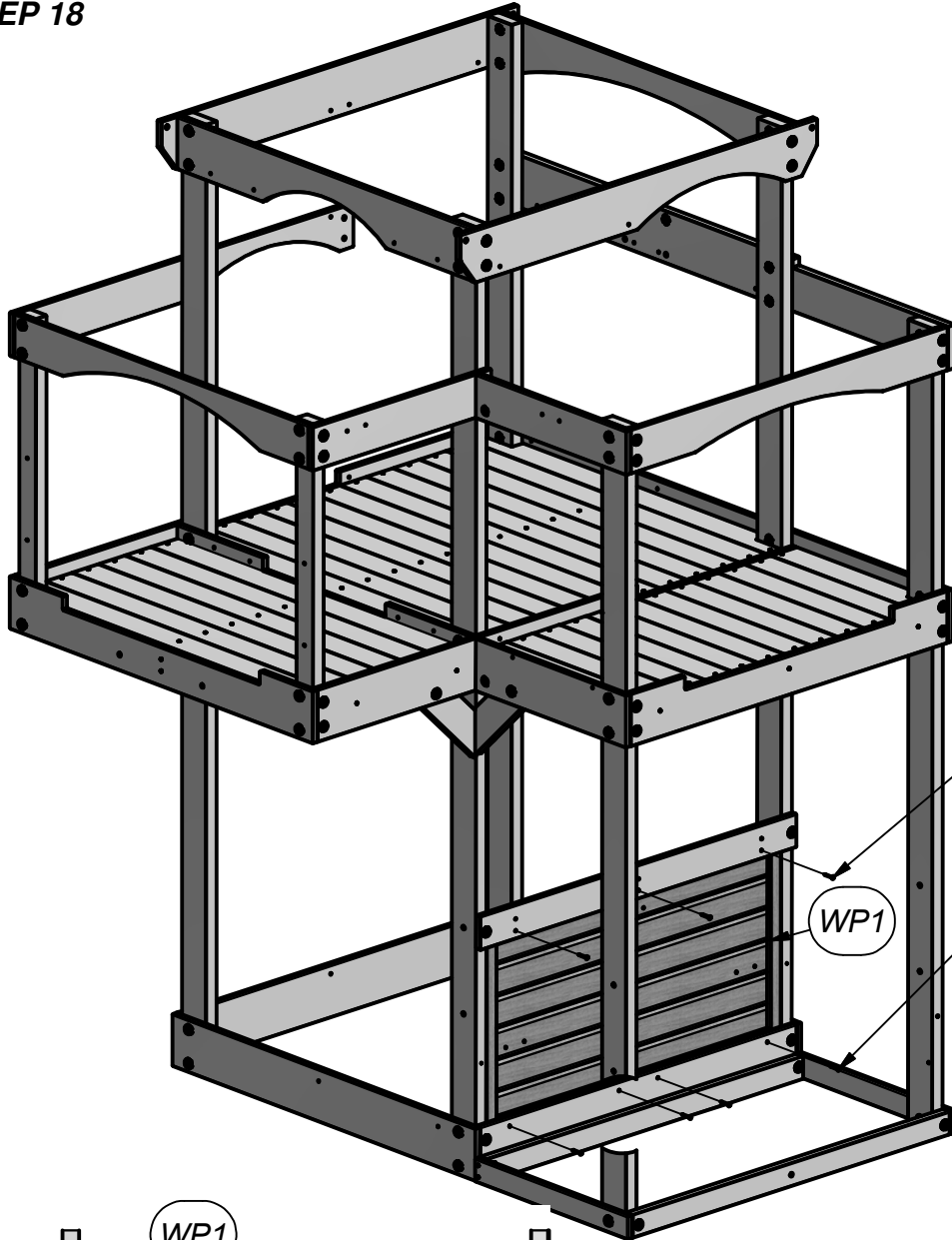

SCREW PFH 8x1 1/4 BLK  
(3 PLCS)

WP1

SCREW PFH 8x1 1/4 BLK  
(4 PLCS)

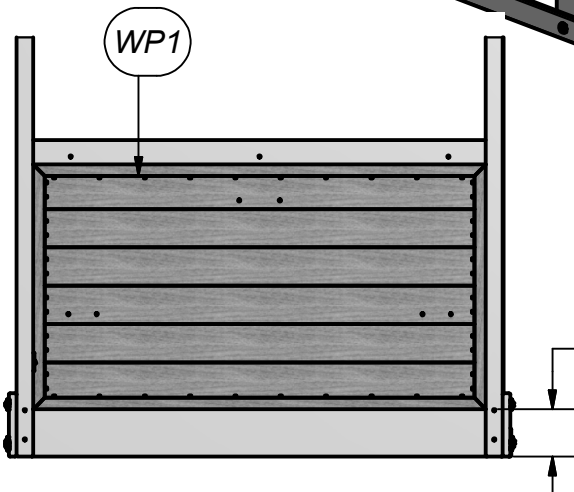



(1) *T4 - SUPPORT BOARD - W4L07613*  
*1"x1 3/8"x37 3/4" (24x34x958)*

**STEP 19**

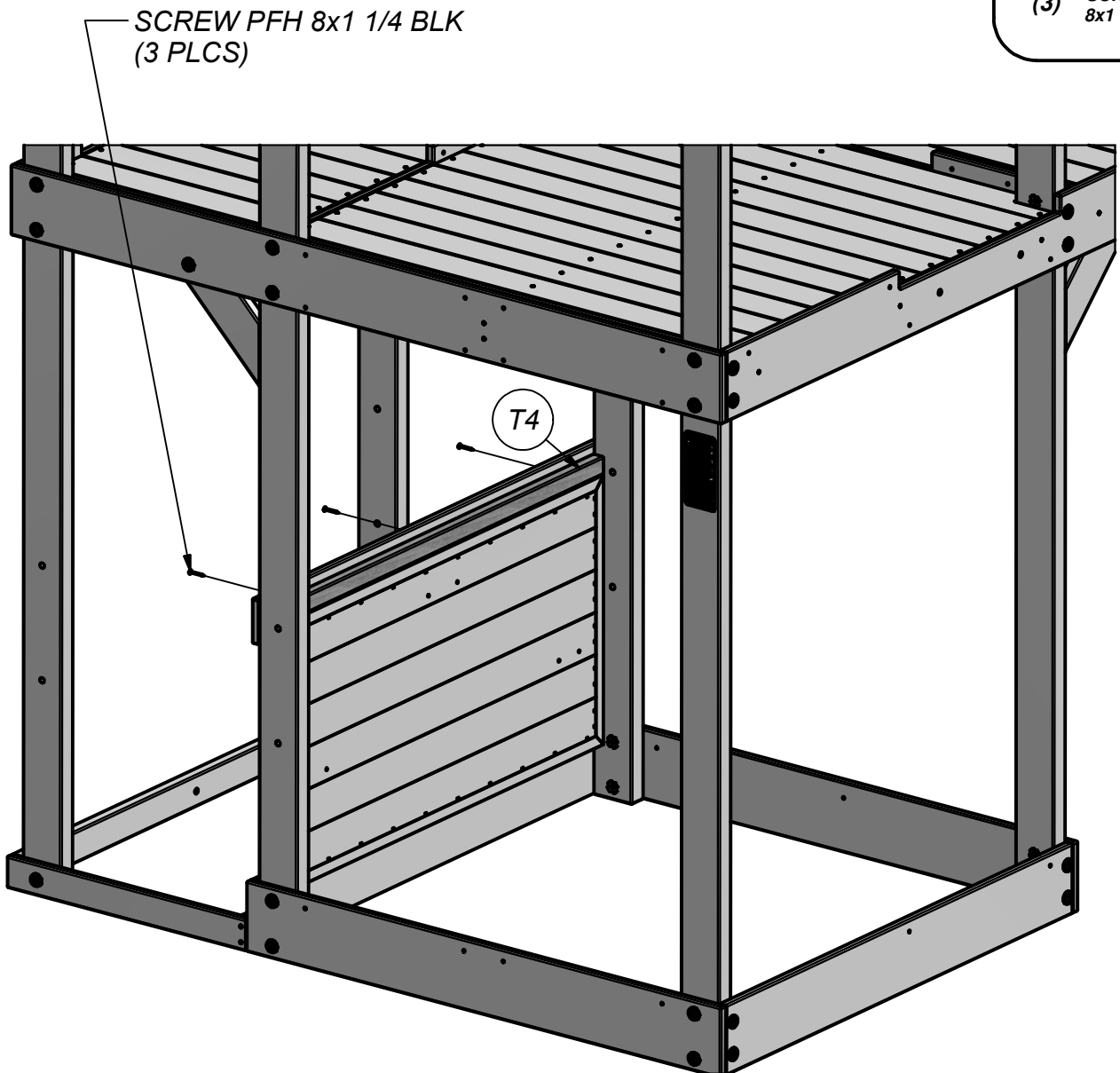
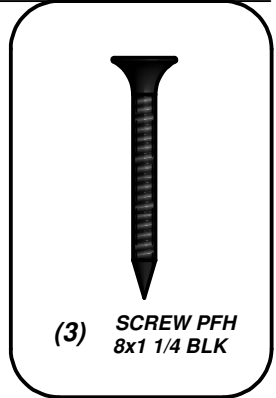



(2) **J6 - SUPPORT BLOCK - W4L07589**  
1"x2 3/8"x6 1/4" (24x60x160)

**STEP 20**

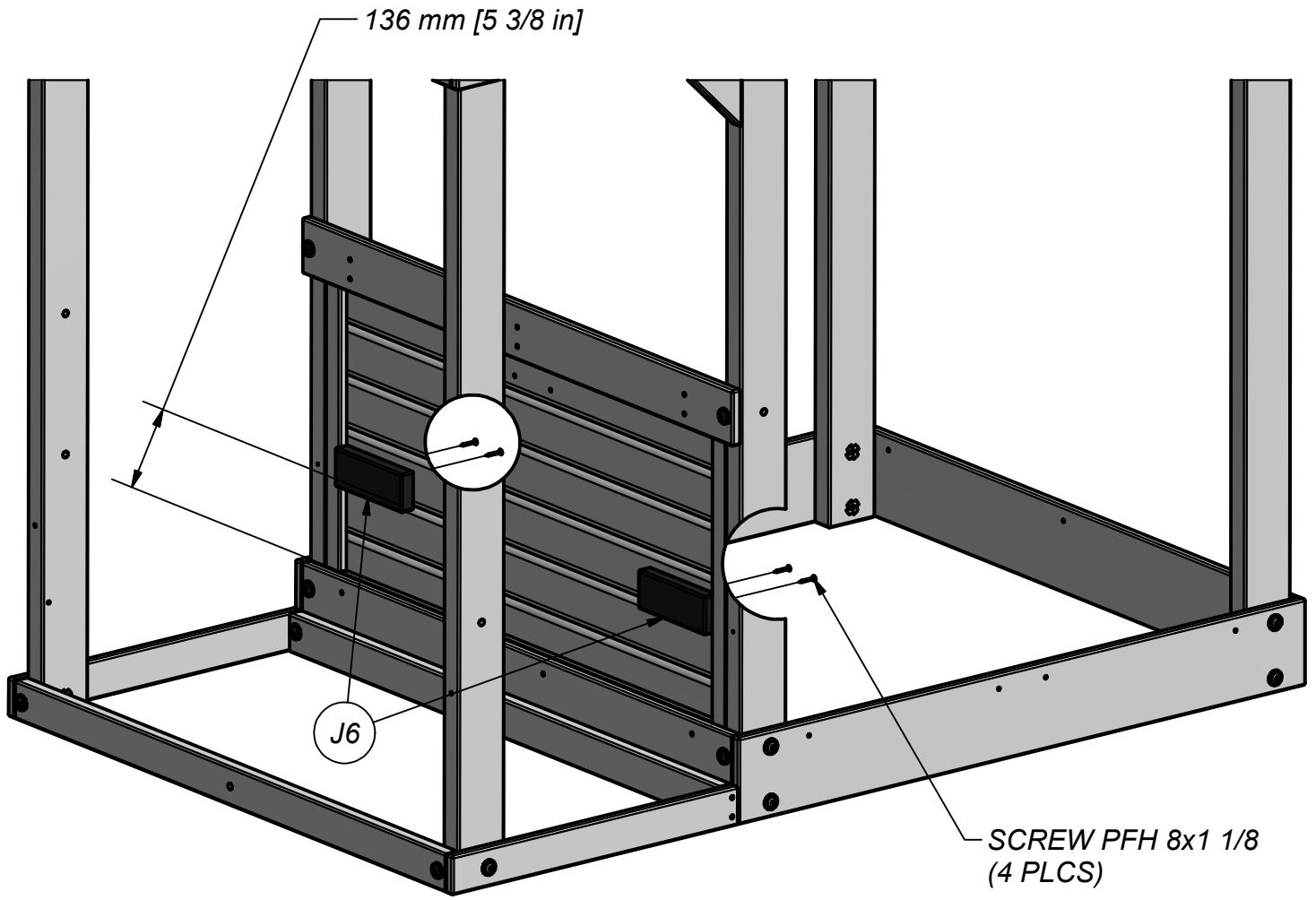
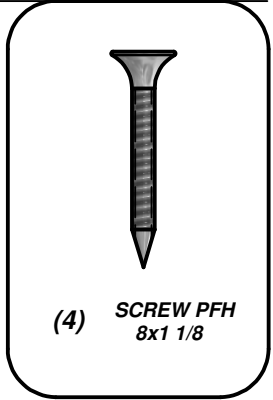



(1) **H1 - TABLE SUPPORT - W4L07583**  
1"x3 3/8"x22 3/8" (24x86x567)



(1) **J7 - SUPPORT BLOCK - W4L07595**  
1"x2 3/8"x3 3/8" (24x60x86)

### STEP 21

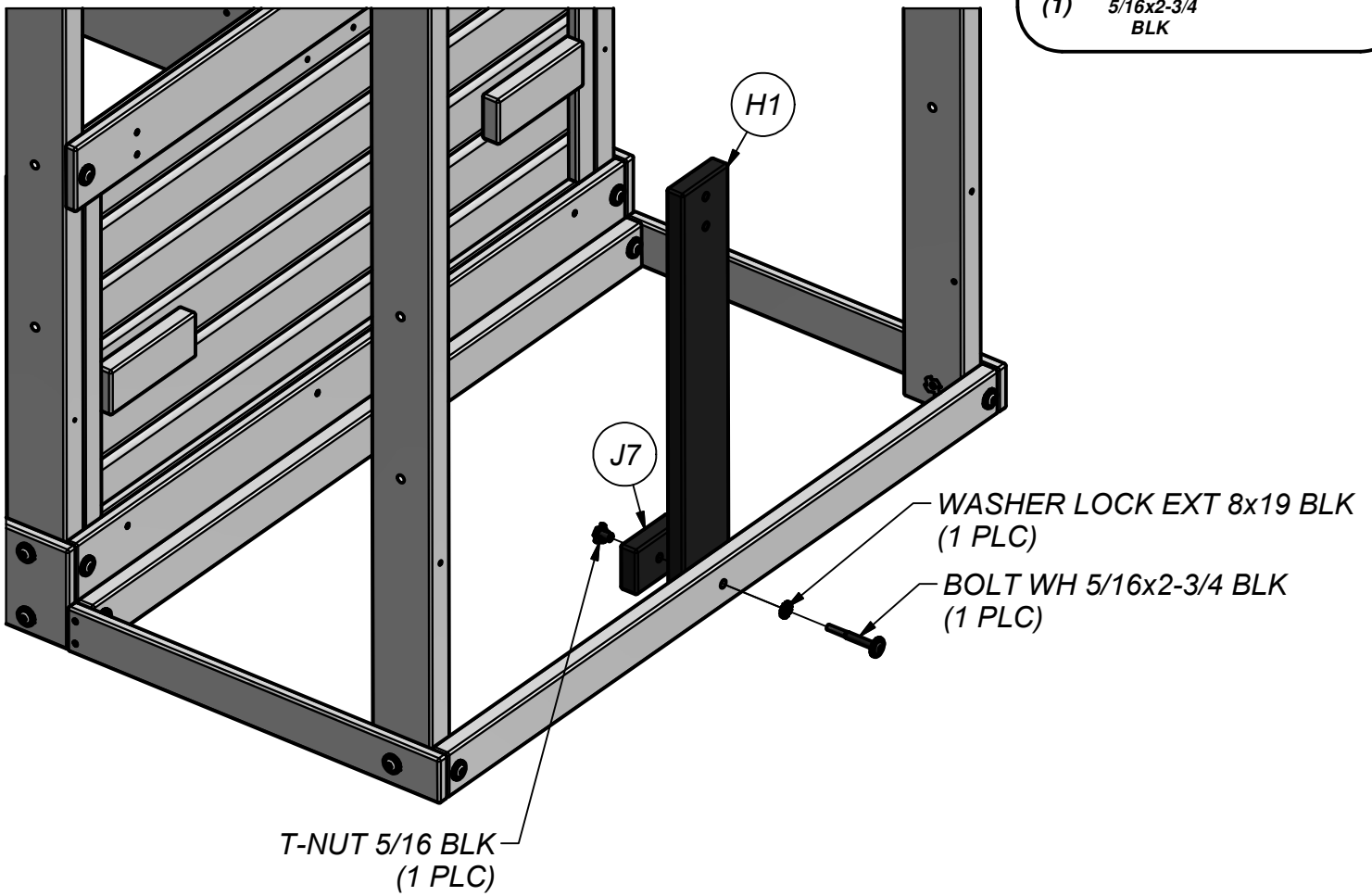
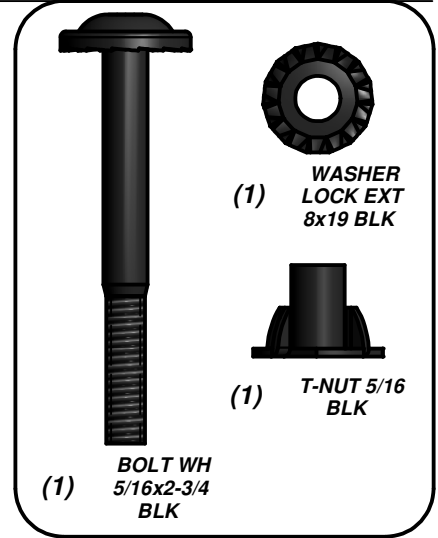



(8) **M4 - FLOOR BOARD - W4L07597**  
5/8"x3 3/8"x21 1/8" (16x86x537)



(1) **M5 - FLOOR BOARD - W4L07598**  
5/8"x3 3/8"x19 1/4" (16x86x488)



(2) **K17 - FLOOR BOARD - W4L07596**  
5/8"x5 1/4"x21 1/8" (16x134x537)

## STEP 22

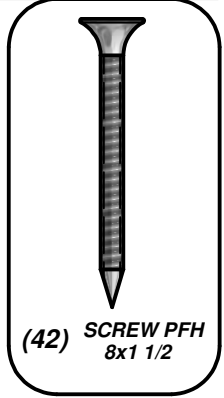

(42) **SCREW PFH**  
8x1 1/2

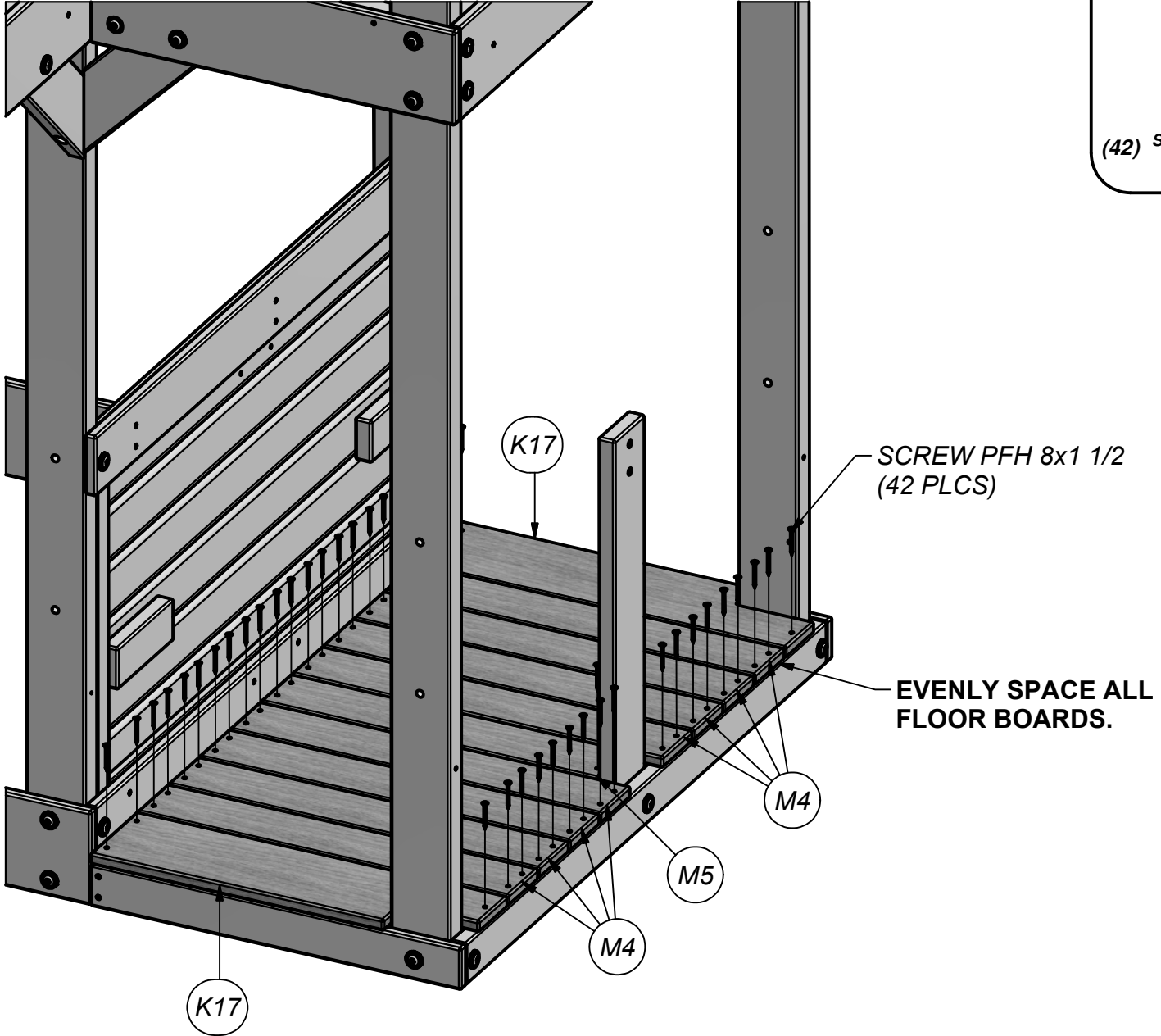



(2) **J3 - BENCH SUPPORT - W4L07586**  
1"x2 3/8"x9" (24x60x230)

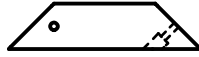

(2) **J4 - ANGLE BRACE - W4L07587**  
1"x2 3/8"x10" (24x60x254)



(2) **J5 - SUPPORT BLOCK - W4L07588**  
1"x2 3/8"x2 7/8" (24x60x72)

**STEP 23**

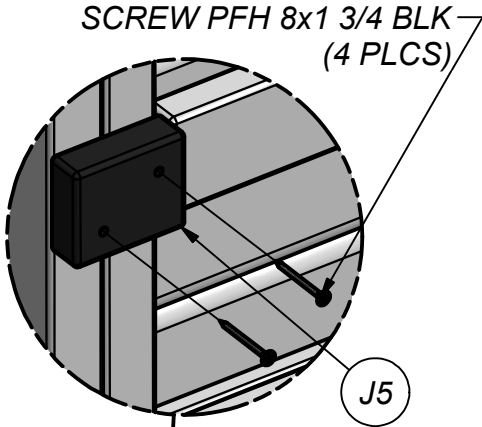

**SCREW PFH 8x1 3/4 BLK**  
(4 PLCS)

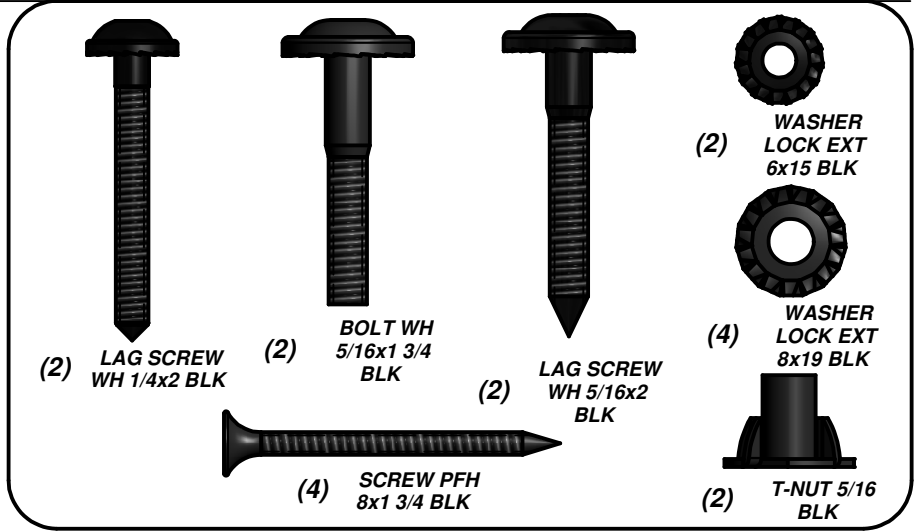

(2) **LAG SCREW**  
WH 1/4x2 BLK

(2) **BOLT WH**  
5/16x1 3/4  
BLK

(2) **LAG SCREW**  
WH 5/16x2  
BLK

(2) **WASHER**  
LOCK EXT  
6x15 BLK

(4) **WASHER**  
LOCK EXT  
8x19 BLK

(2) **T-NUT** 5/16  
BLK

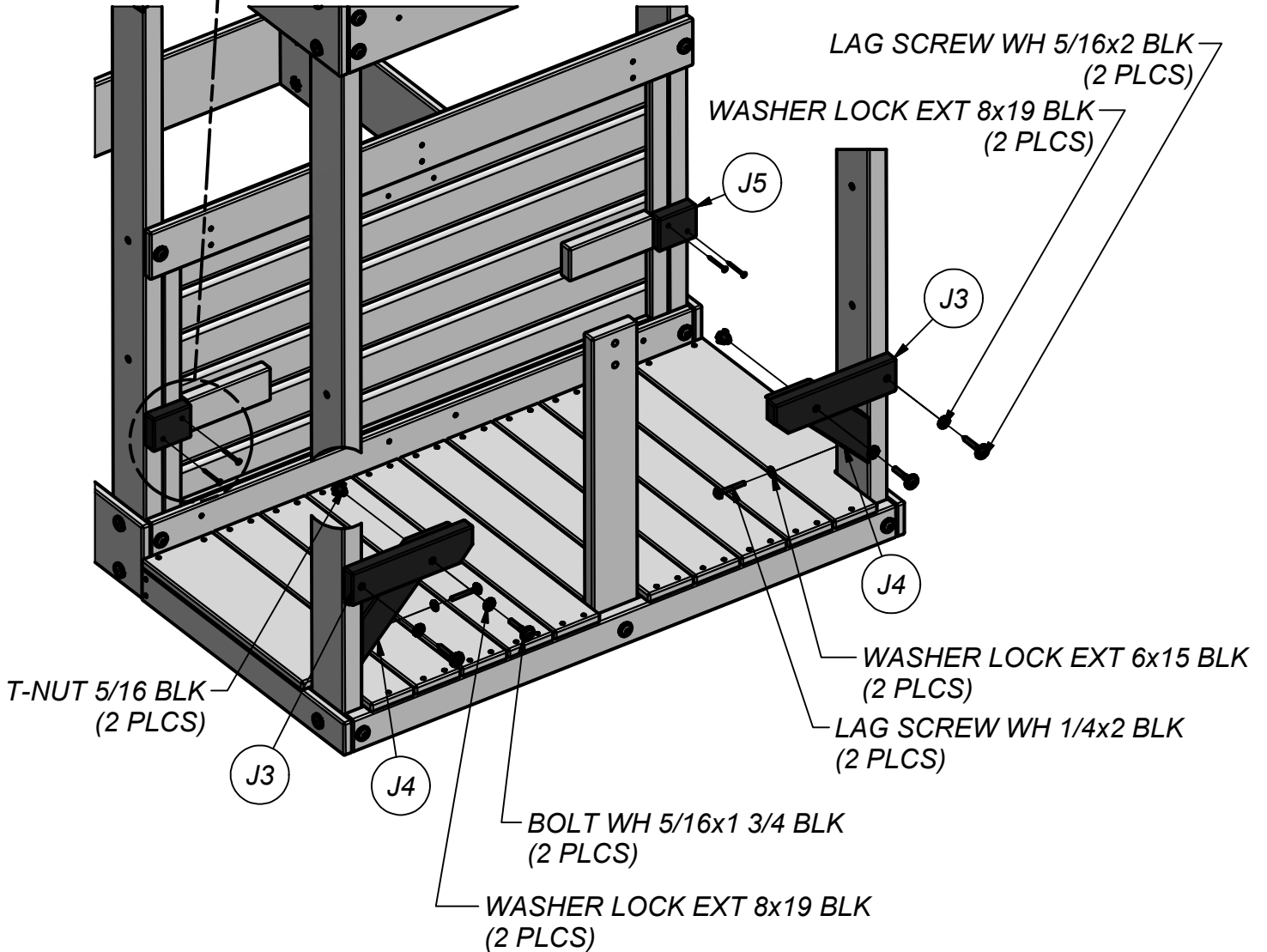

**LAG SCREW WH 5/16x2 BLK**  
(2 PLCS)

**WASHER LOCK EXT 8x19 BLK**  
(2 PLCS)

J5

J3

J4

**WASHER LOCK EXT 6x15 BLK**  
(2 PLCS)

**LAG SCREW WH 1/4x2 BLK**  
(2 PLCS)

**T-NUT 5/16 BLK**  
(2 PLCS)

J3

J4

**BOLT WH 5/16x1 3/4 BLK**  
(2 PLCS)

**WASHER LOCK EXT 8x19 BLK**  
(2 PLCS)



(2) **M2 - BENCH BOARD - W4L07591**  
5/8"x3 3/8"x23" (16x86x583)

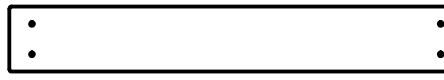

(2) **M3 - TABLE BOARD - W4L07593**  
5/8"x3 3/8"x23" (16x86x583)

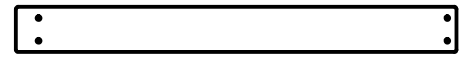

(2) **N3 - BENCH BOARD - W4L07592**  
5/8"x2 3/8"x23" (16x60x583)

### STEP 24

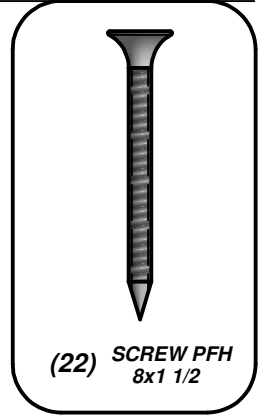
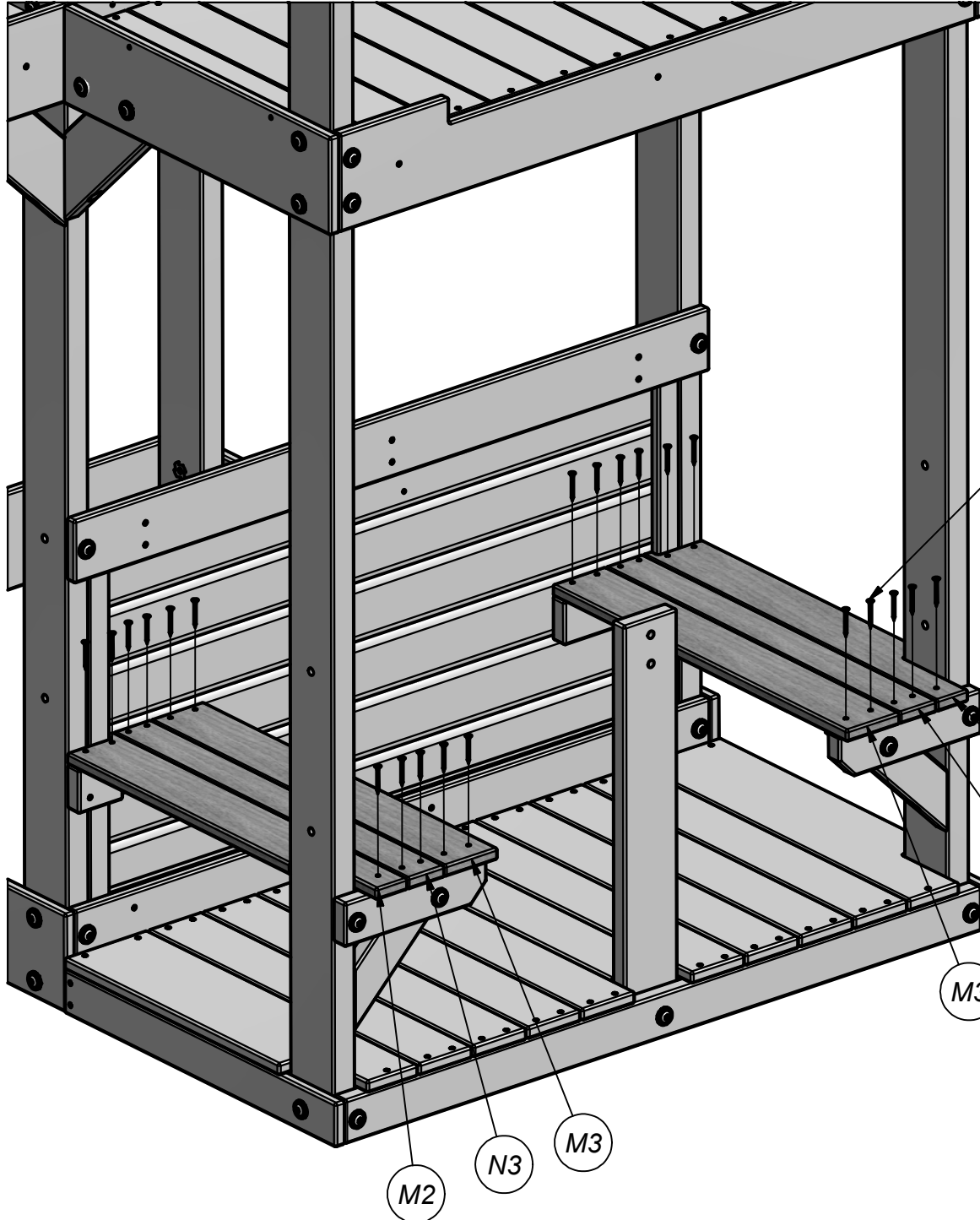

SCREW PFH 8x1 1/2  
(22 PLCS)



(1) **K16 - TABLE BOARD - W4L07594**  
5/8"x5 1/4"x23" (16x134x583)



(2) **M3 - TABLE BOARD - W4L07593**  
5/8"x3 3/8"x23" (16x86x583)

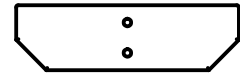

(1) **H2 - TABLE SUPPORT - W4L07584**  
1"x3 3/8"x11 5/8" (24x86x295)



(1) **H3 - TABLE SUPPORT - W4L07585**  
1"x3 3/8"x11 5/8" (24x86x295)

**STEP 25**

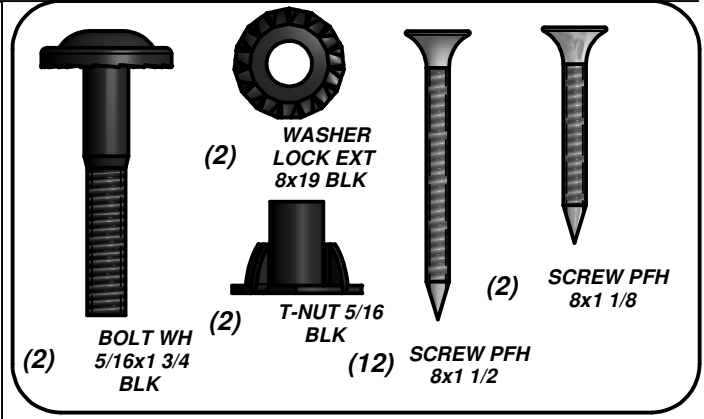
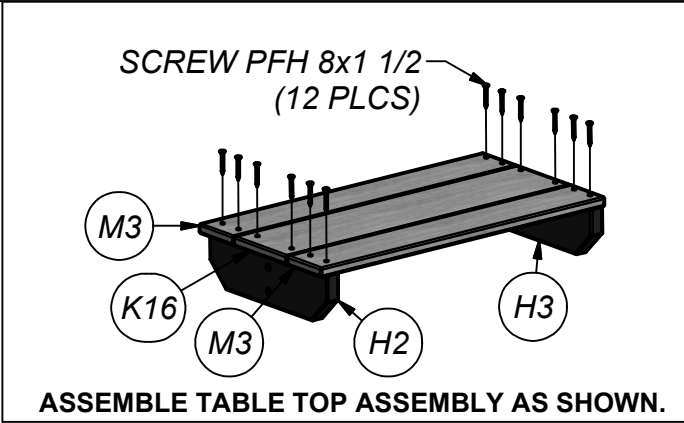

**INSTALL T-NUTS INTO PARTS BEFORE ASSEMBLY OF PARTS.**

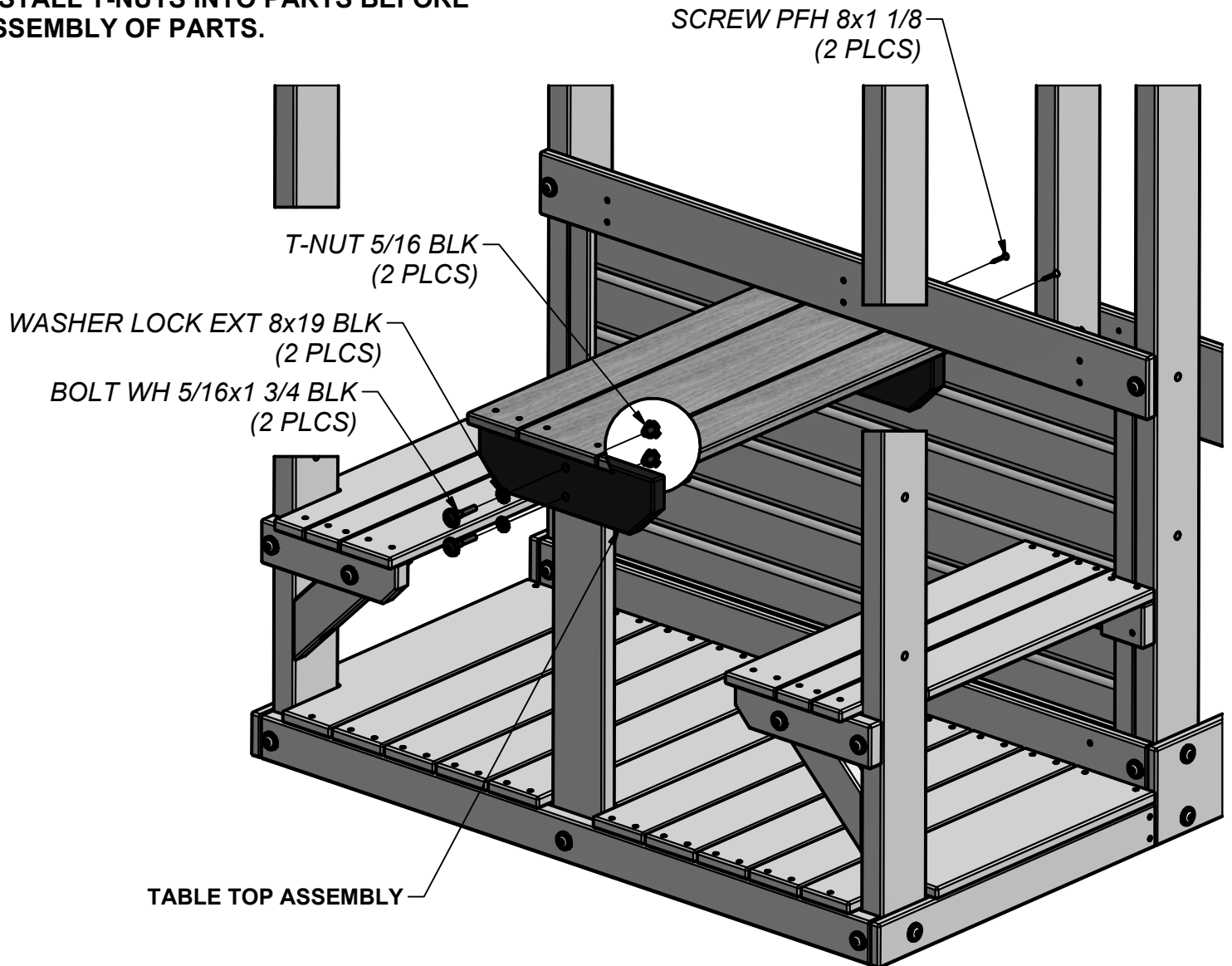

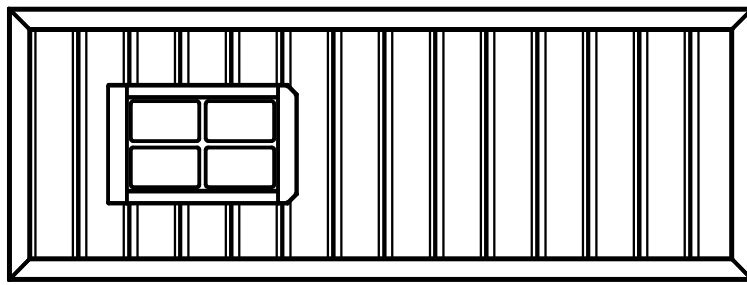

(2) WP2 - RIGHT LOWER WALL PANEL - W2A02083  
 1"x16 7/8"x46 1/2" (24x430x1181)

**STEP 26**

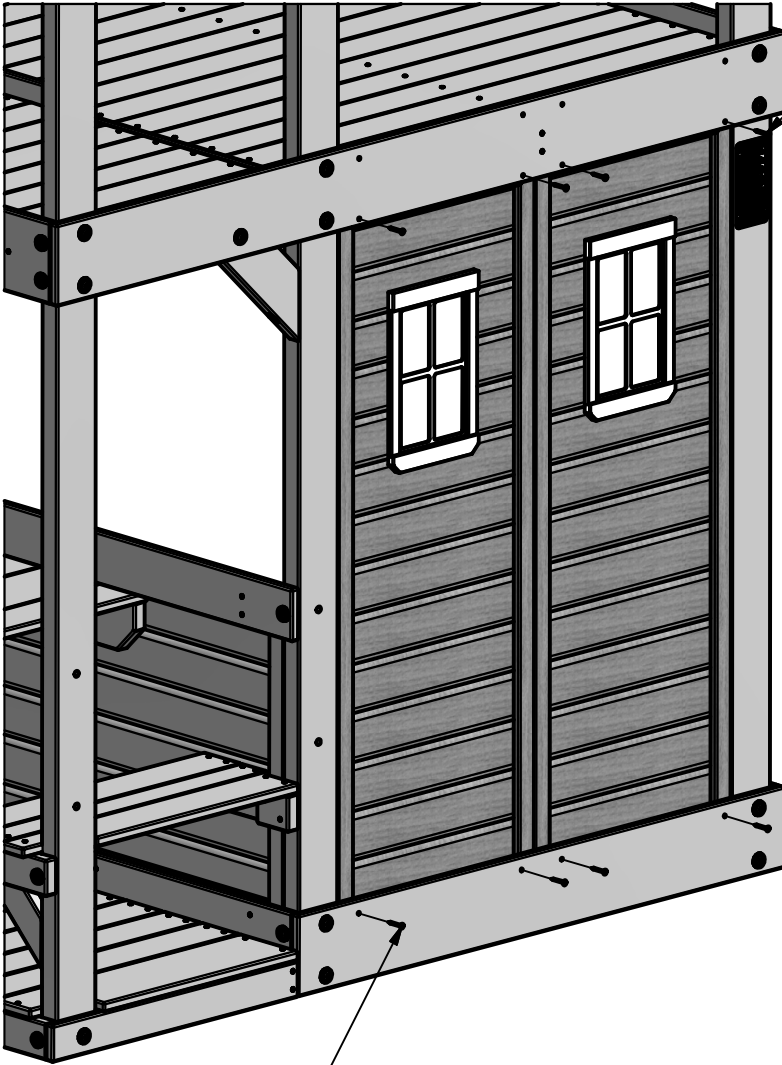

SCREW PFH 8x1 1/4 BLK  
 (4 PLCS)

SCREW PFH 8x1 1/4 BLK  
 (4 PLCS)

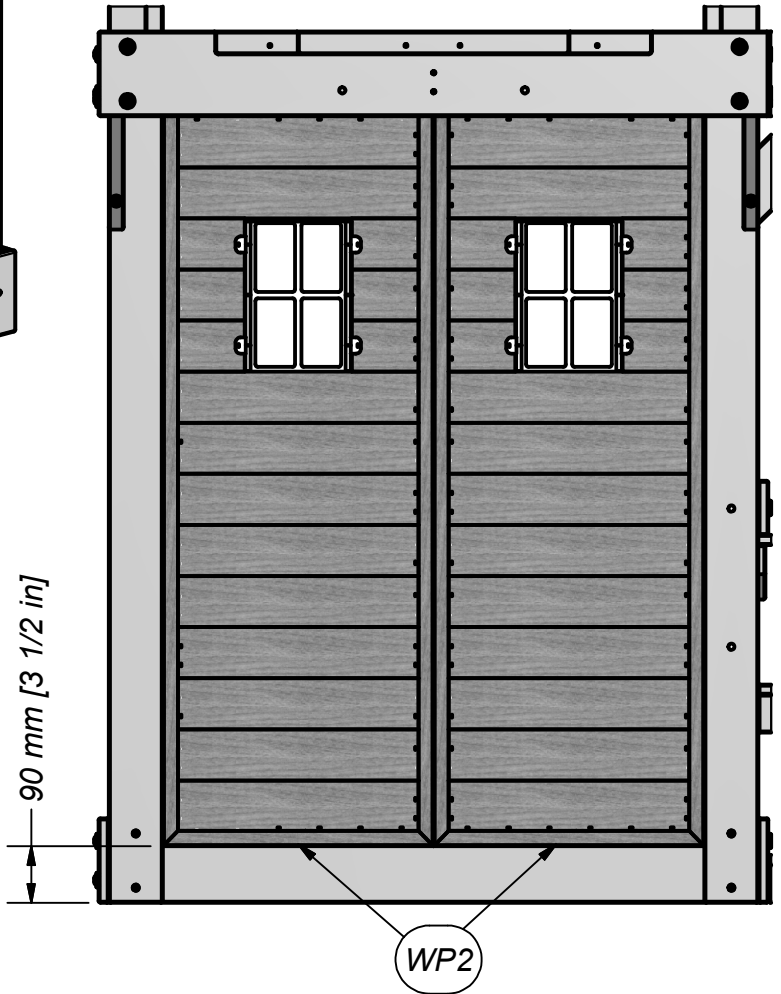
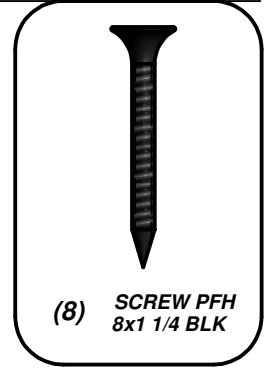

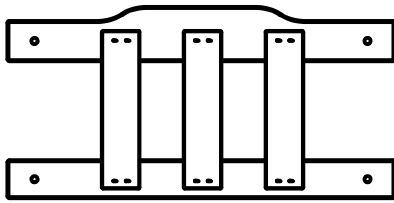

(1) **WP10 - BENCH BACK ASSEMBLY - W2A02081**  
 1 1/8"x11 7/8"x17 5/8" (27x303x615)

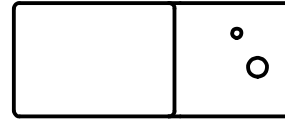

(1) **F3 - SUPPORT BLOCK - W4L07604**  
 1 3/8"x2 3/8"x5 7/8" (36x60x148)

**STEP 27**

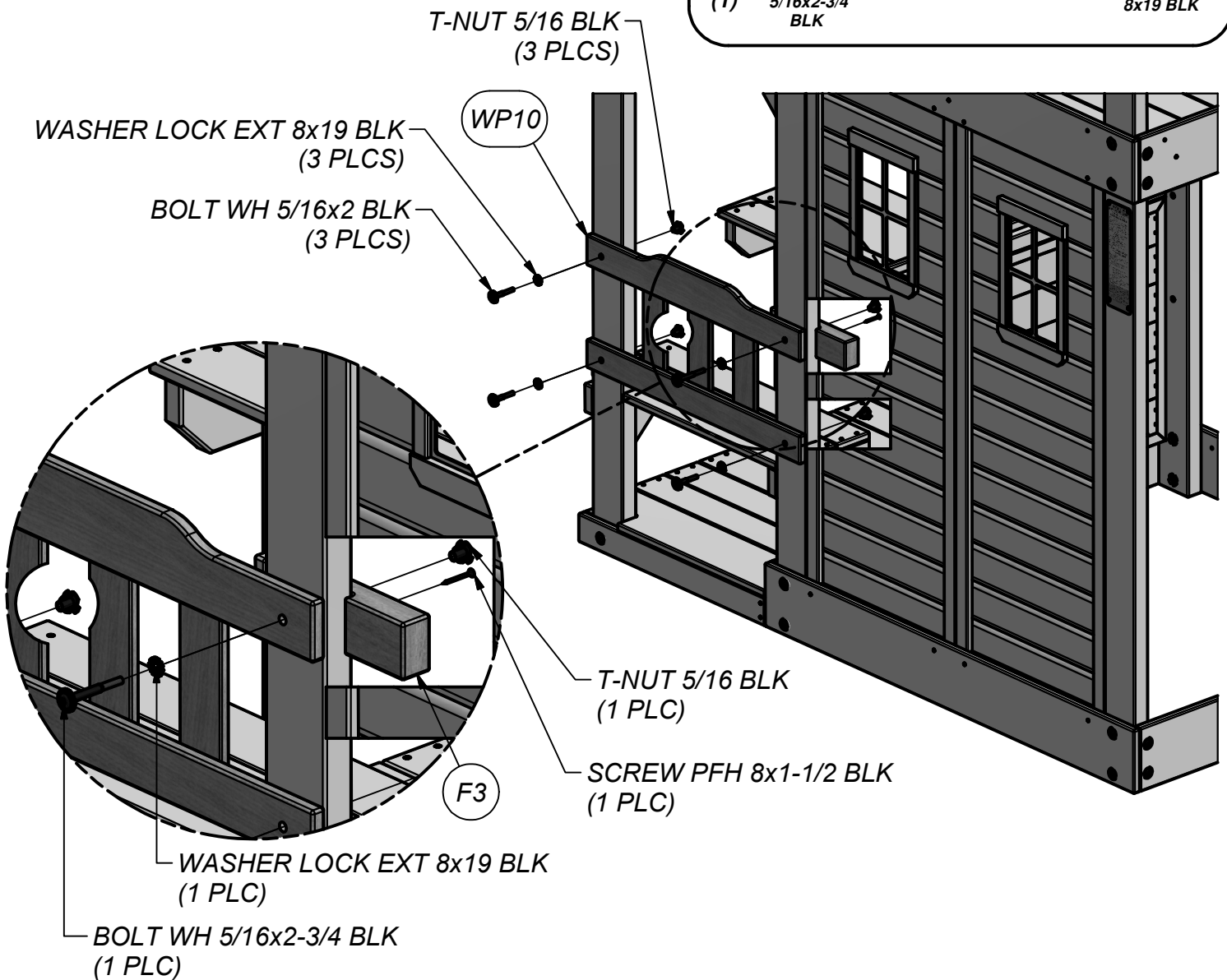
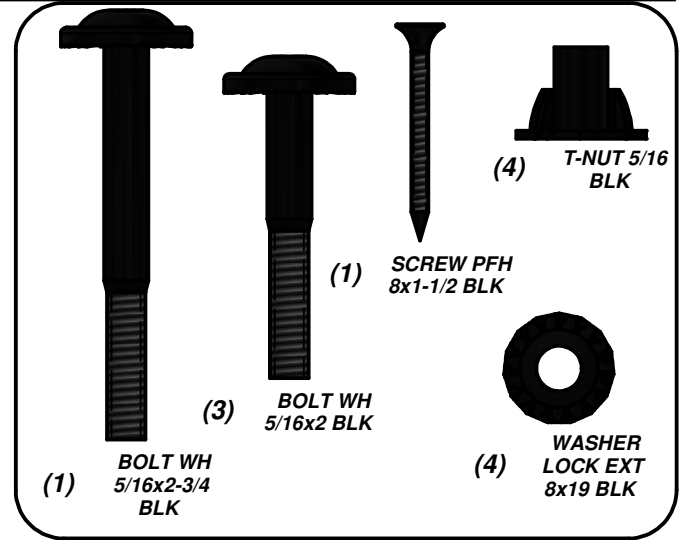

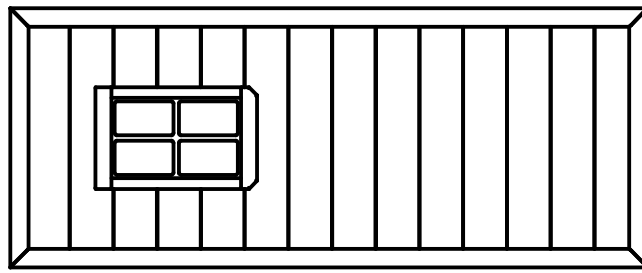

(1) WP9 - LOWER WALL PANEL - W2A02090  
1"x16 7/8"x46 1/2" (24x476x1181)

**STEP 28**

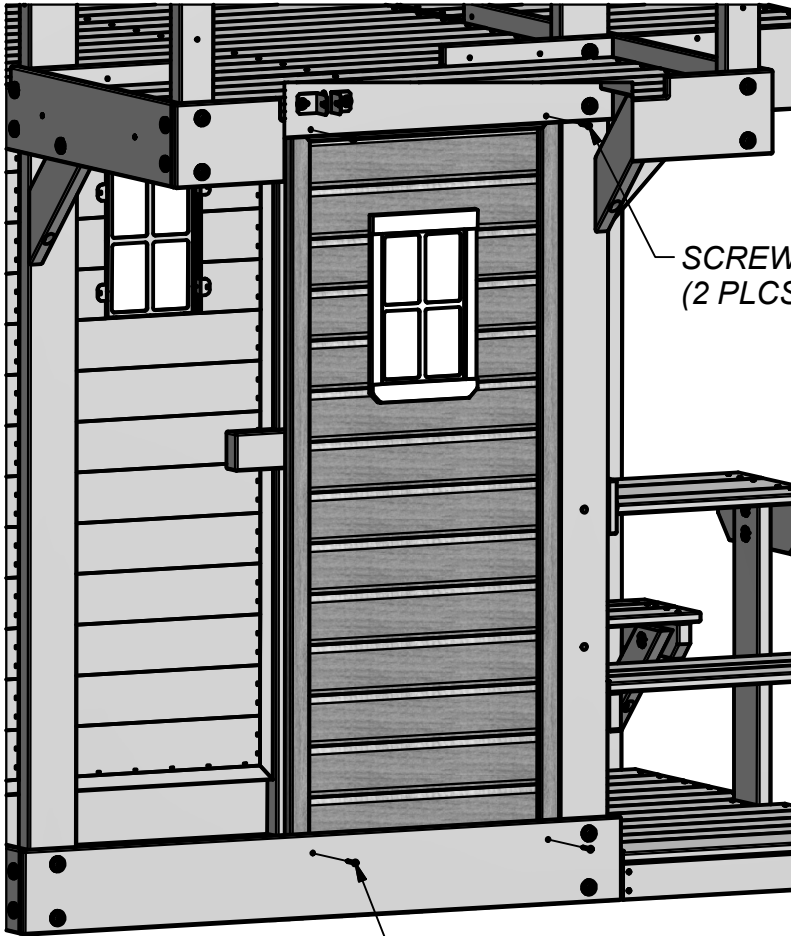

SCREW PFH 8x1 1/4 BLK  
(2 PLCS)

SCREW PFH 8x1 1/4 BLK  
(2 PLCS)

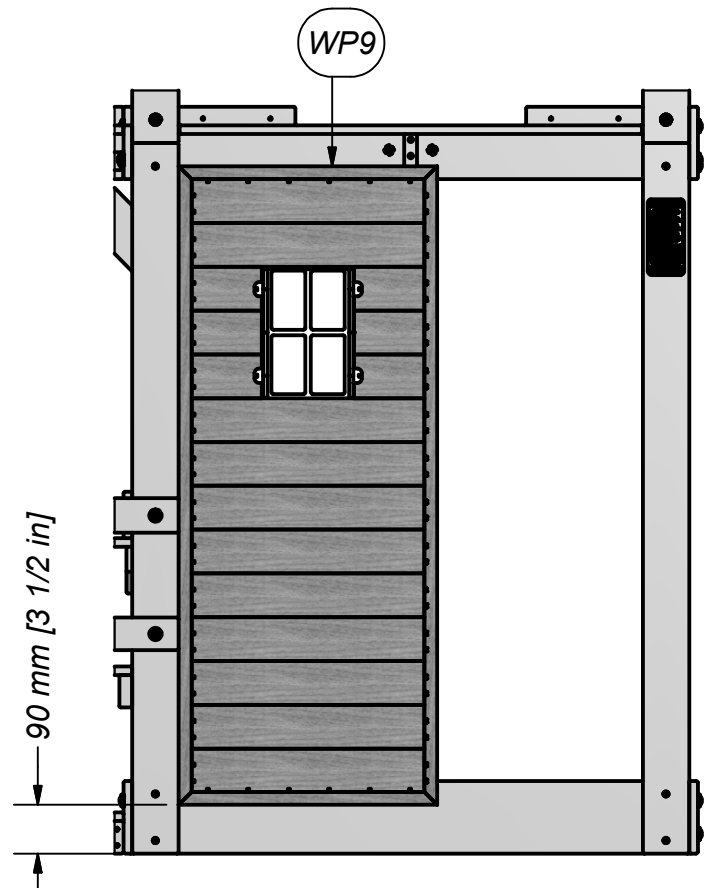
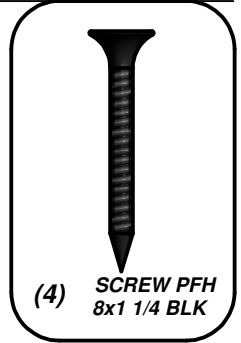

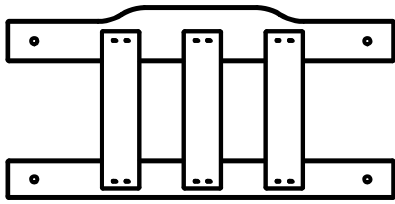

(1) WP10 - BENCH BACK ASSEMBLY - W2A02081  
1 1/8"x11 7/8"x17 5/8" (27x303x615)

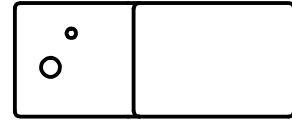

(1) F4 - SUPPORT BLOCK - W4L07614  
1 3/8"x2 3/8"x5 7/8" (36x60x148)

**STEP 29**

T-NUT 5/16 BLK  
(3 PLCS)

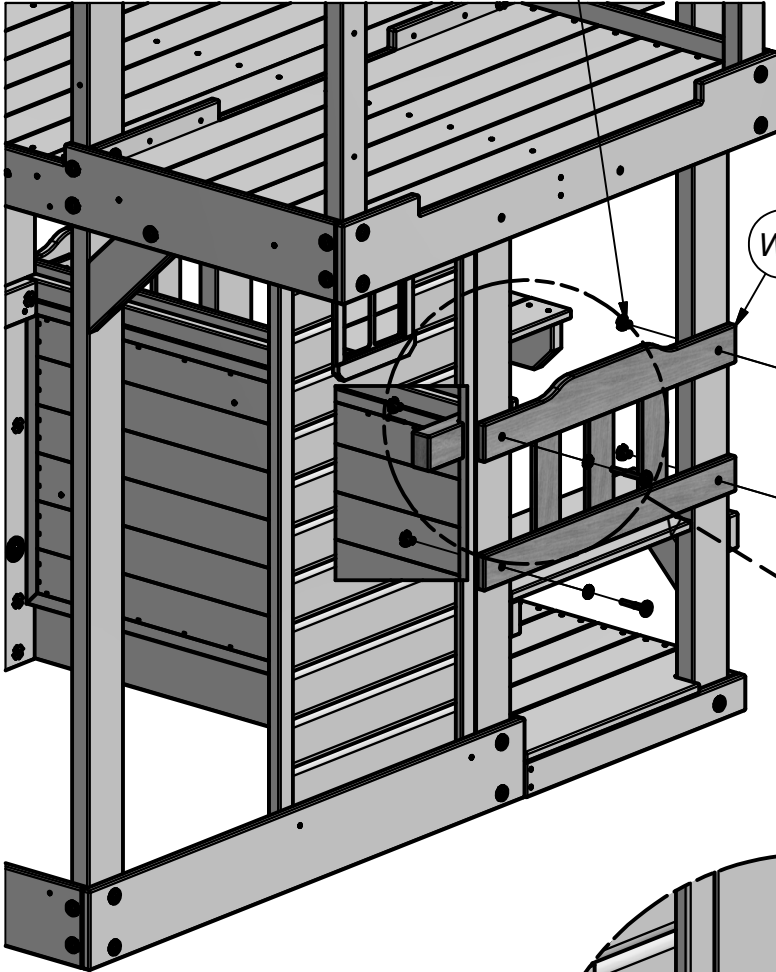

WP10

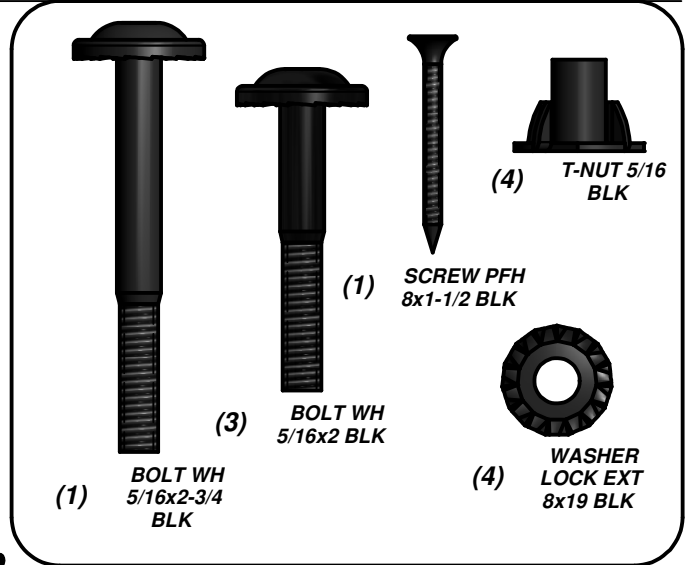

BOLT WH 5/16x2 BLK  
(3 PLCS)

WASHER LOCK EXT 8x19 BLK  
(3 PLCS)

T-NUT 5/16 BLK  
(1 PLC)

SCREW PFH 8x1-1/2 BLK  
(1 PLC)

F4

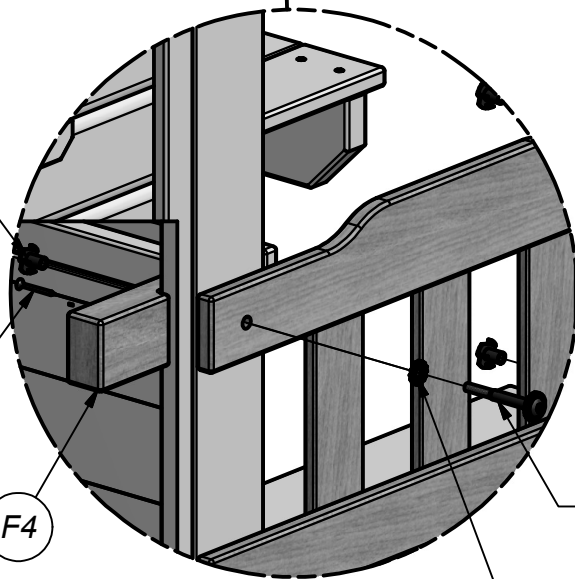

BOLT WH 5/16x2-3/4 BLK  
(1 PLC)

WASHER LOCK EXT 8x19 BLK  
(1 PLC)



(1) **M6 - COUNTER TOP - W4L07605**  
5/8"x3 3/8"x37 5/8" (16x86x957)



(1) **M7 - COUNTER TOP - W4L07606**  
5/8"x3 3/8"x38 5/8" (16x86x981)

**STEP 30**

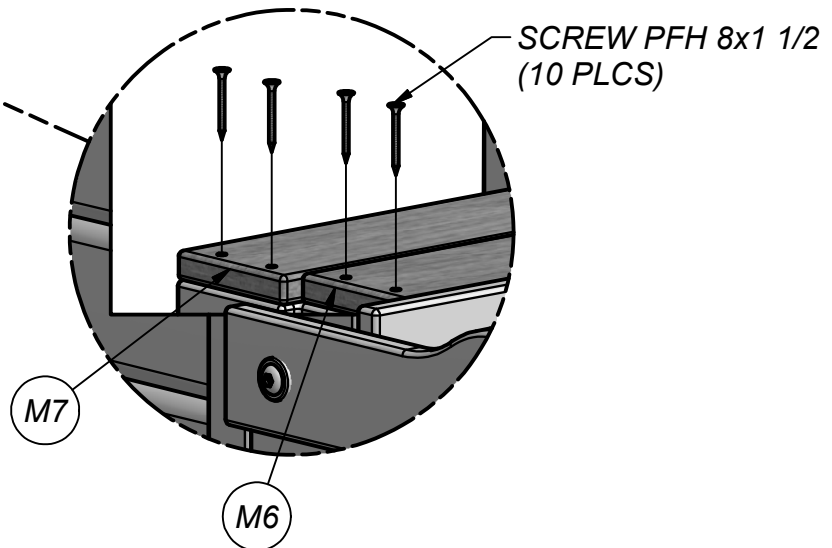
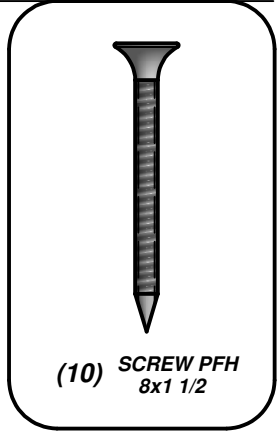
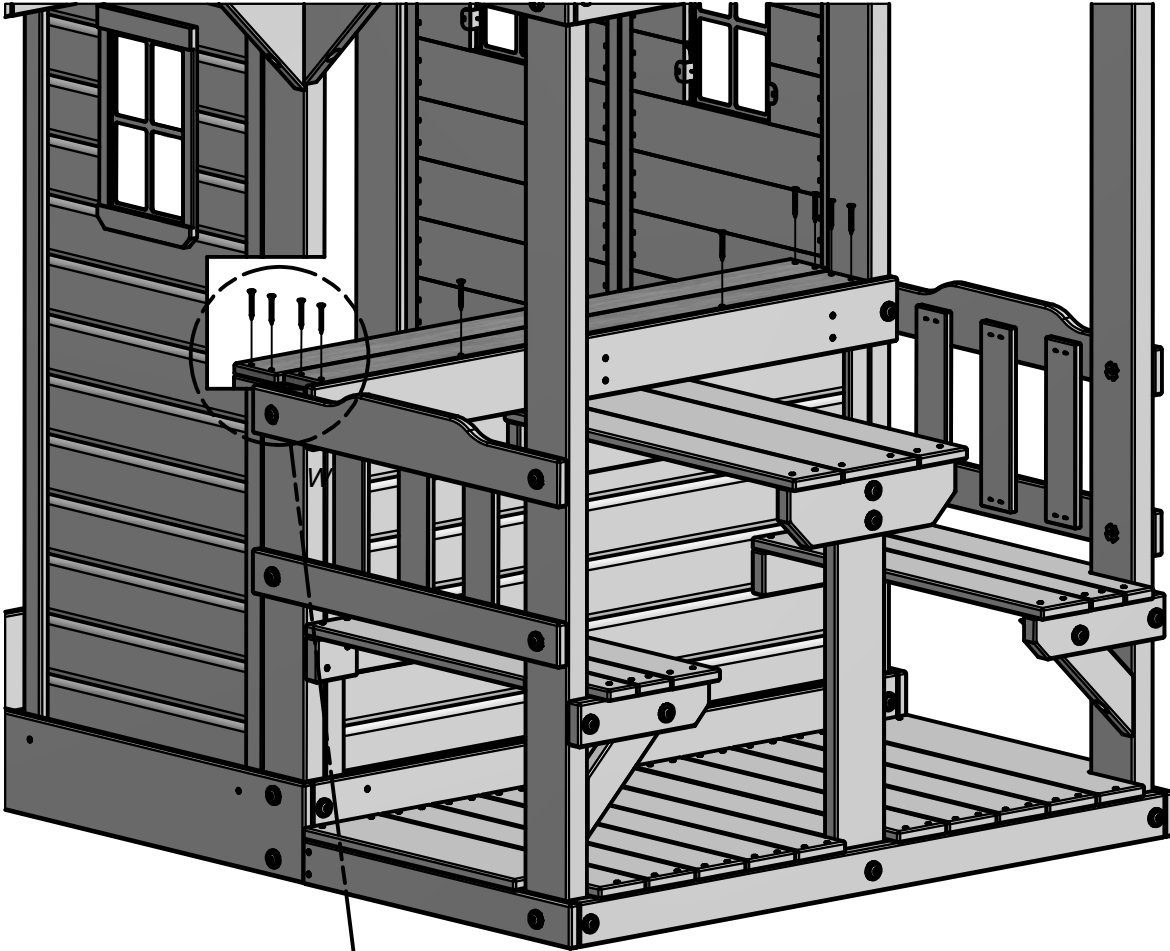

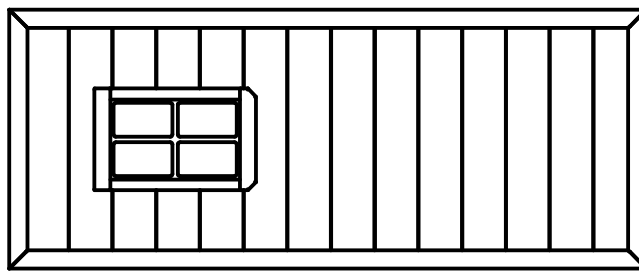

(1) WP9 - LOWER WALL PANEL - W2A02090  
1"x16 7/8"x46 1/2" (24x476x1181)

**STEP 31**

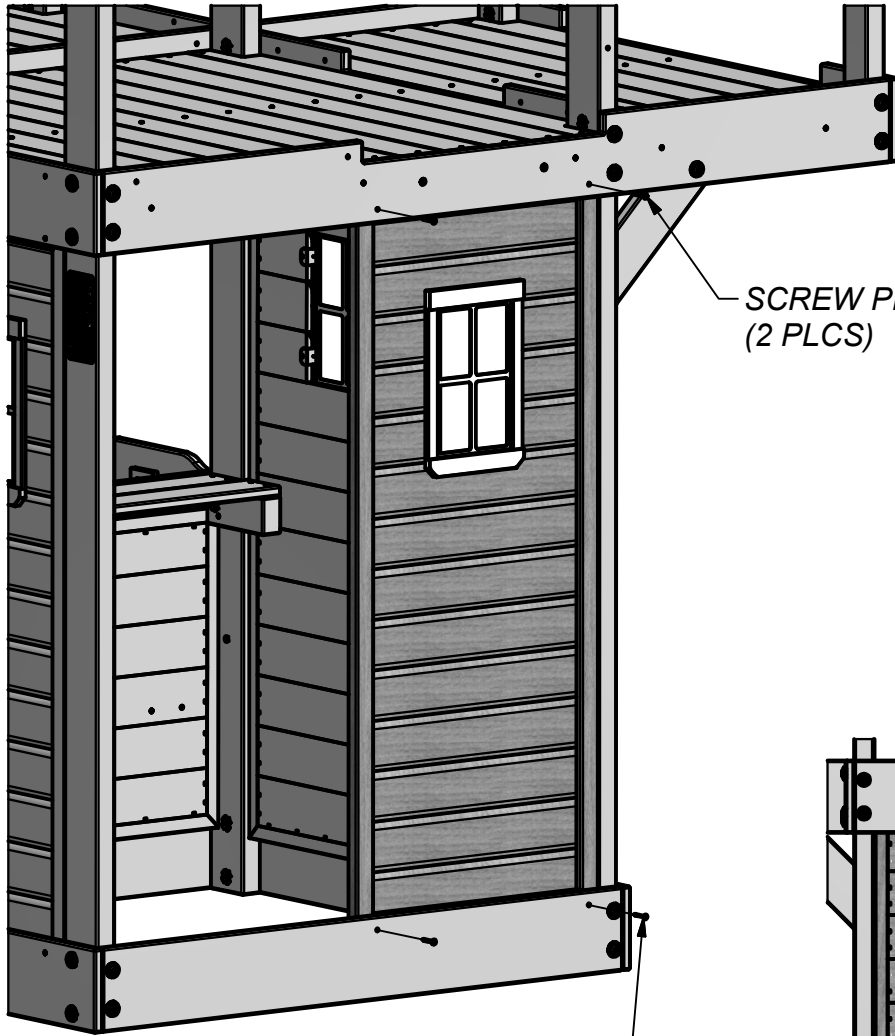

SCREW PFH 8x1 1/4 BLK  
(2 PLCS)

SCREW PFH 8x1 1/4 BLK  
(2 PLCS)

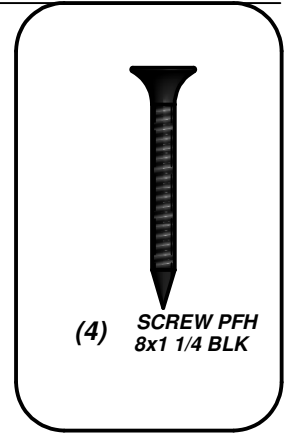

(4) SCREW PFH  
8x1 1/4 BLK

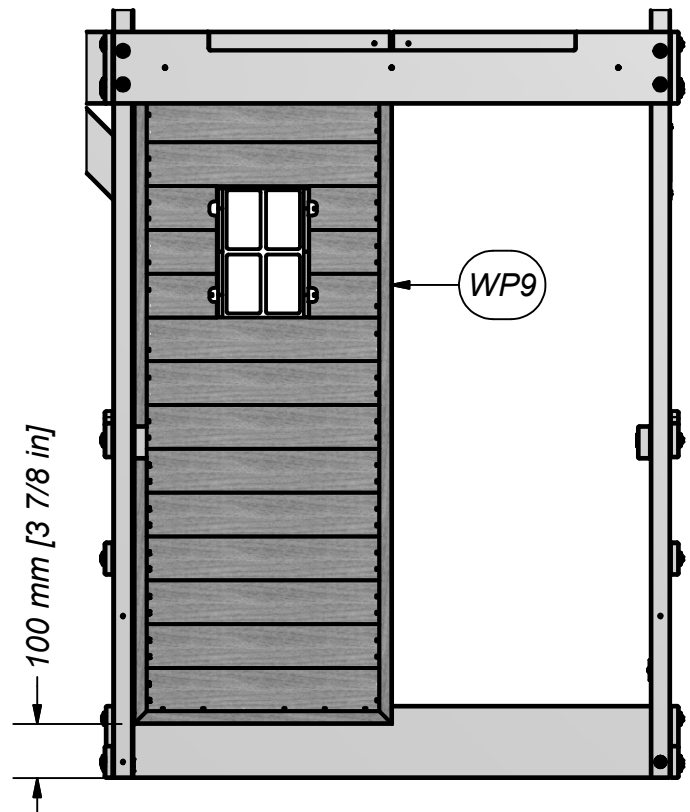

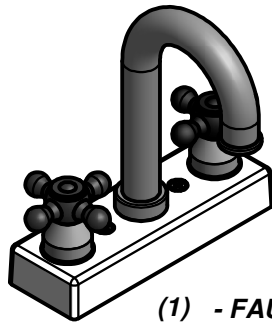

(1) - FAUCET KIT - A6P00024

STEP 32

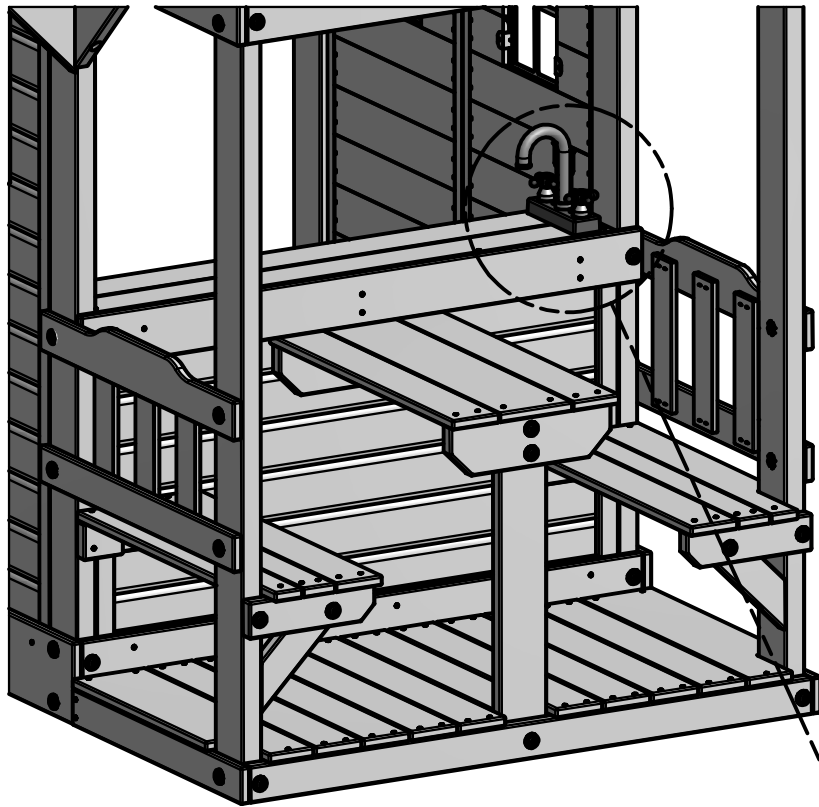
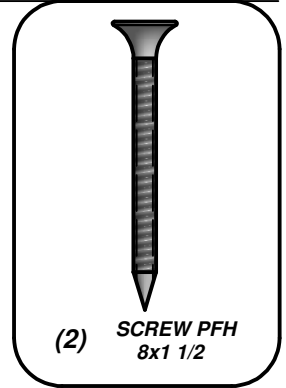

SCREW PFH 8x1 1/2  
(2 PLCS)

FAUCET KIT

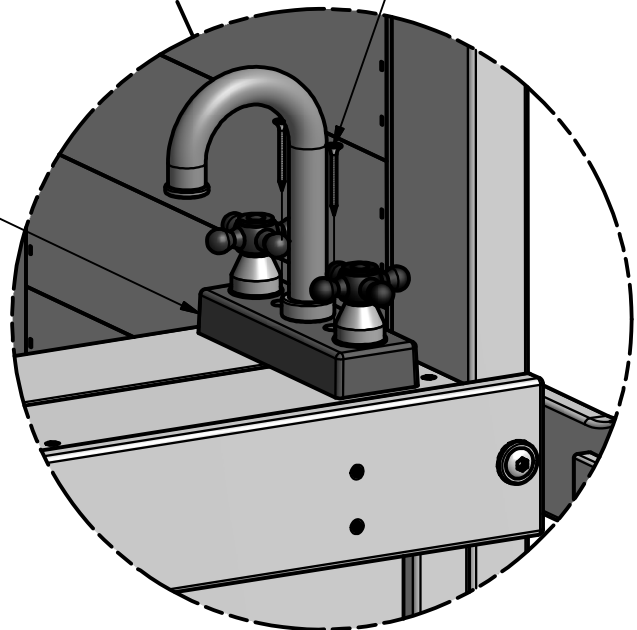

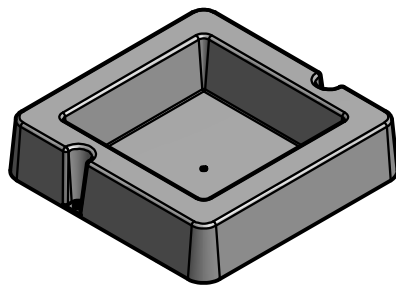

(1) - SURFACE MOUNT BASIN - A6P00032

STEP 33

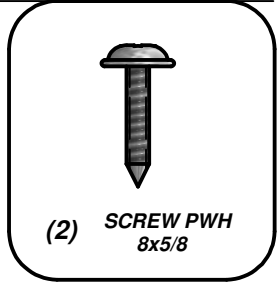
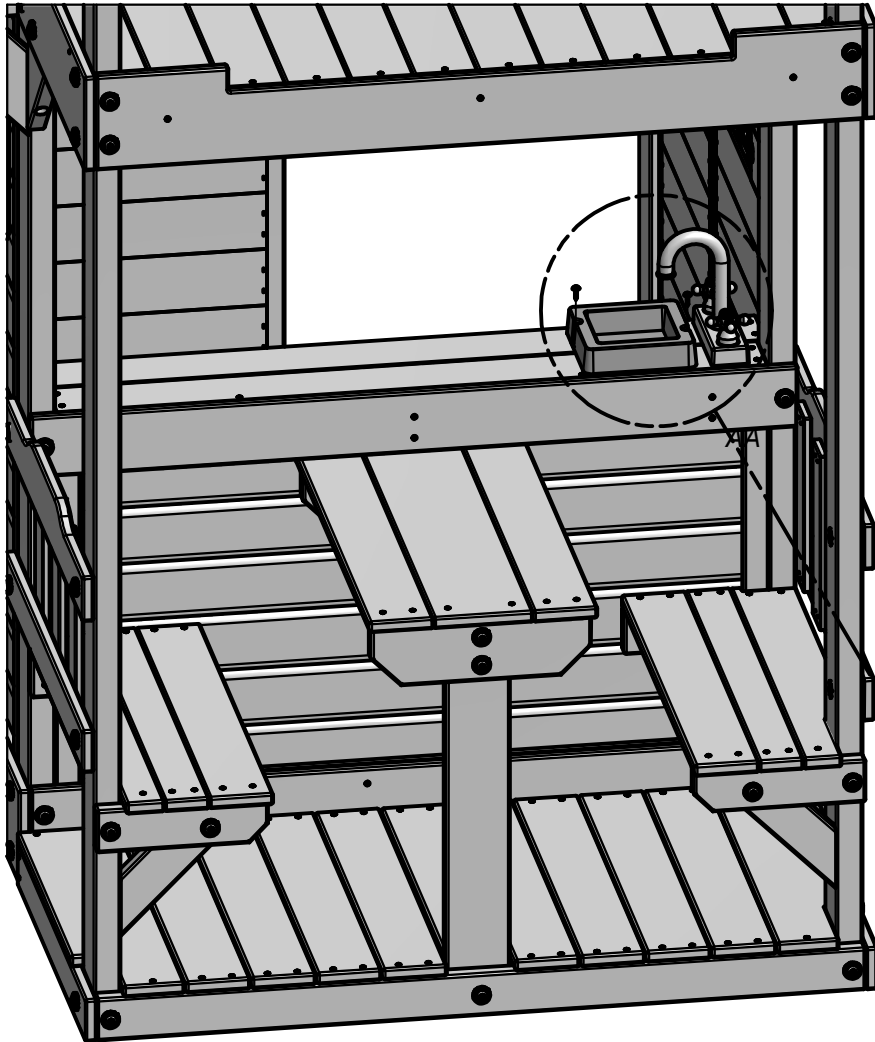

SCREW PWH 8x5/8  
(2 PLCS)

SURFACE MOUNT BASIN

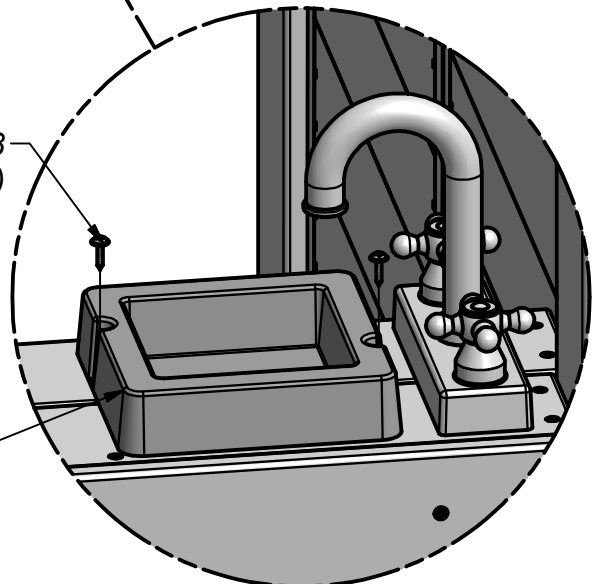

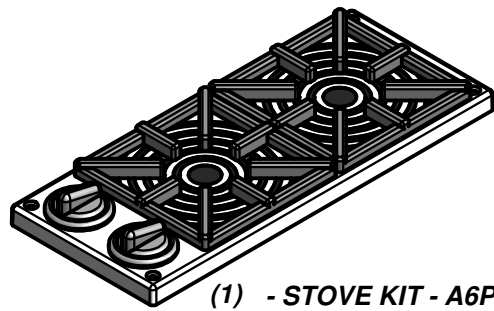

(1) - STOVE KIT - A6P00025

**STEP 34**

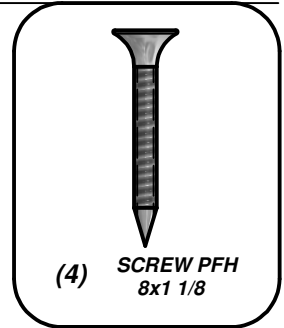
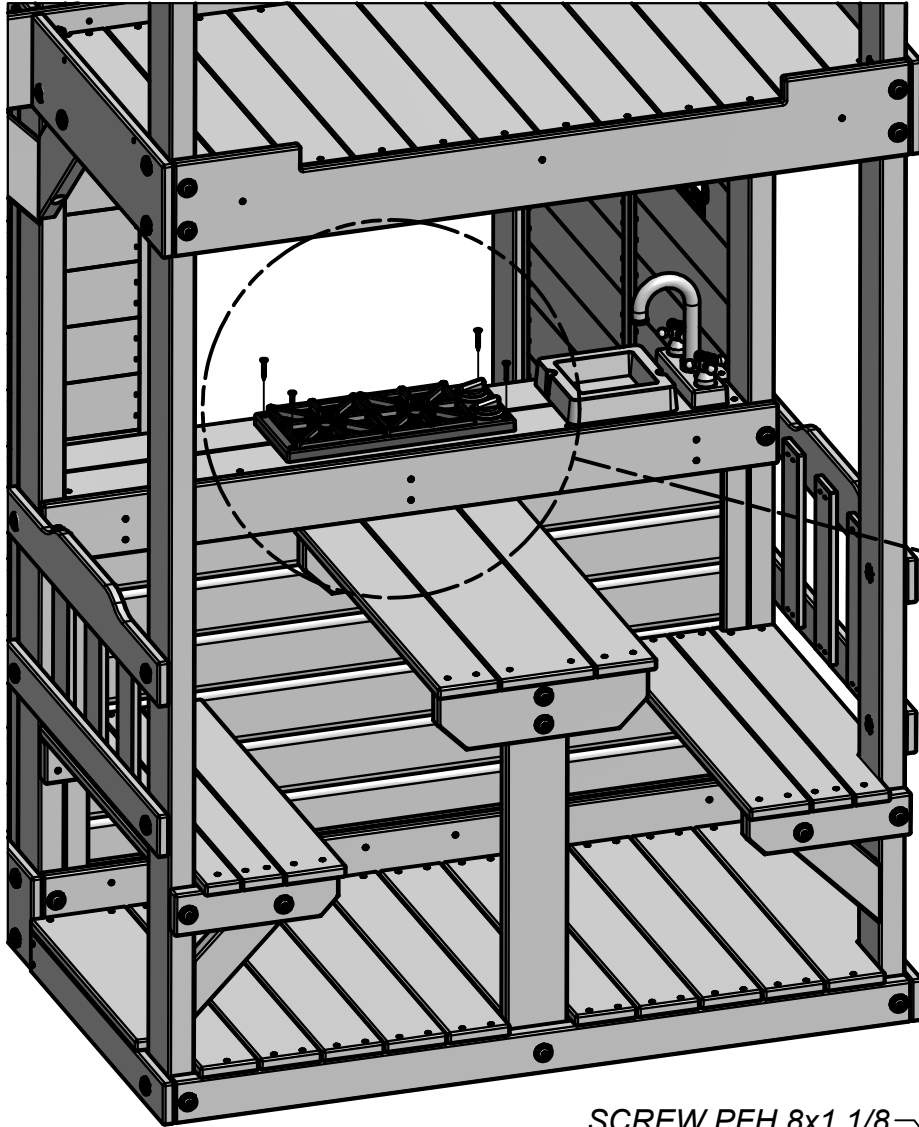

(4) SCREW PFH  
8x1 1/8

SCREW PFH 8x1 1/8  
(4 PLCS)

STOVE KIT

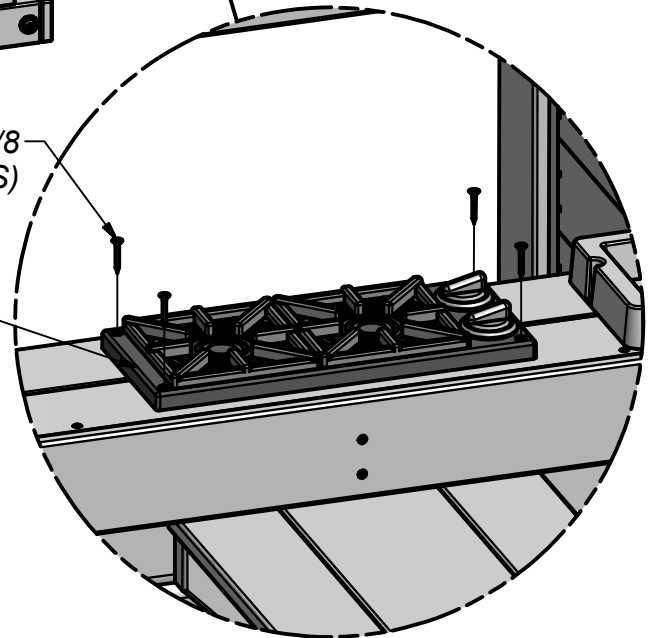

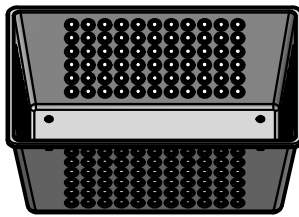

(1) FRUIT BASKET KIT - A6P00069

STEP 35

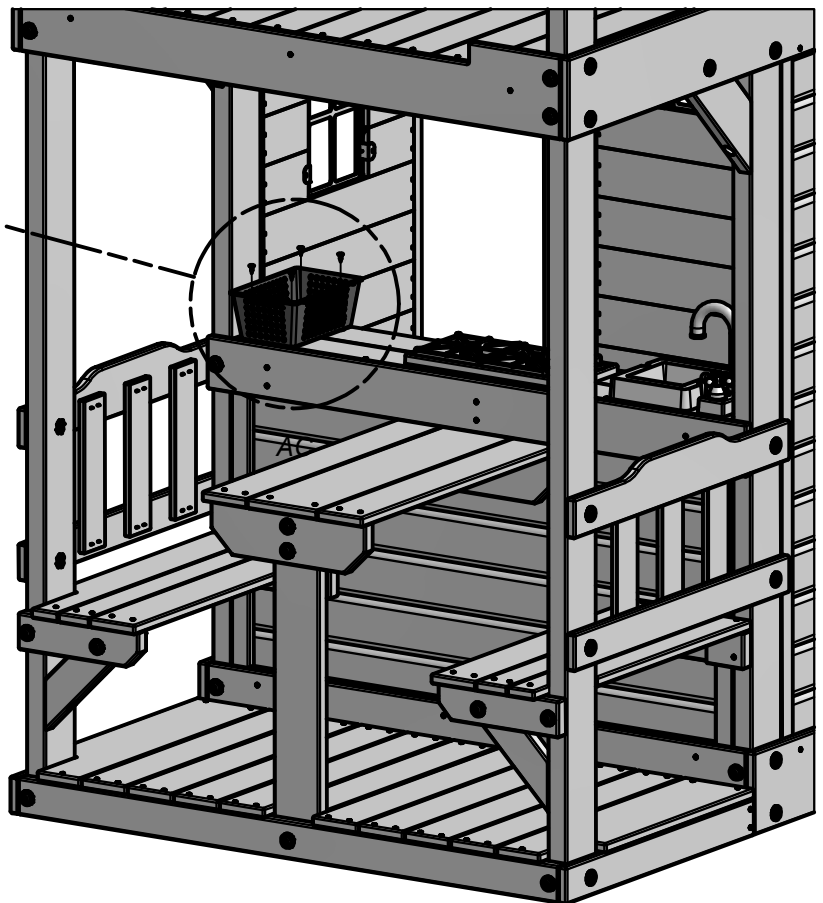
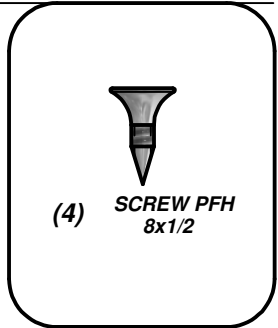
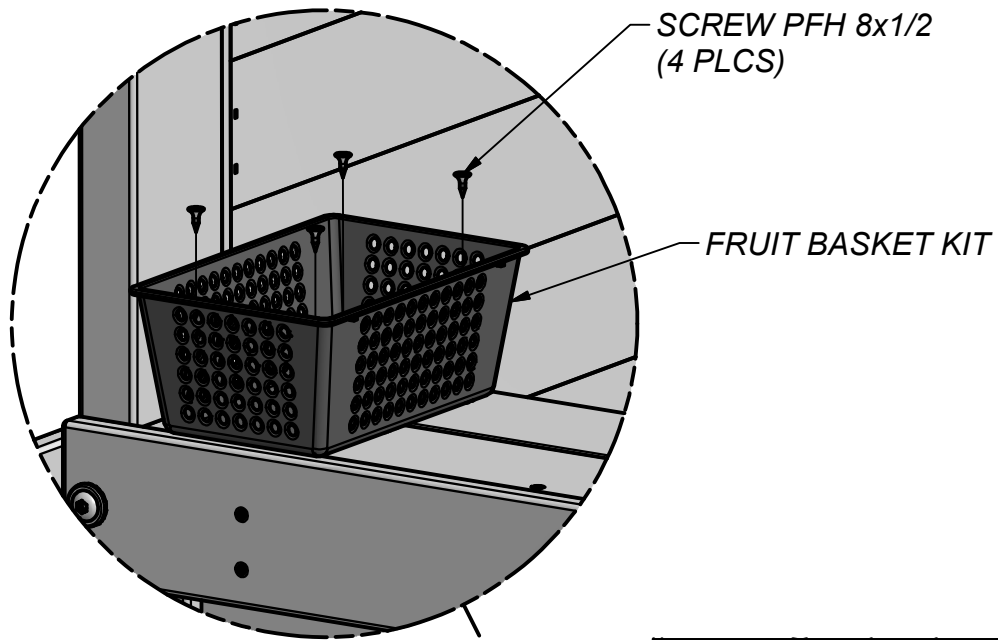

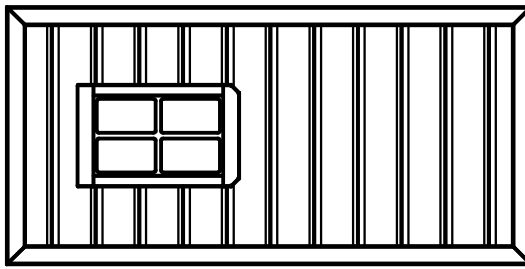

(1) WP7 - TOP FRONT WALL PANEL - W2A02088  
1"x16 7/8"x38 1/4" (24x476x971)

**STEP 36**

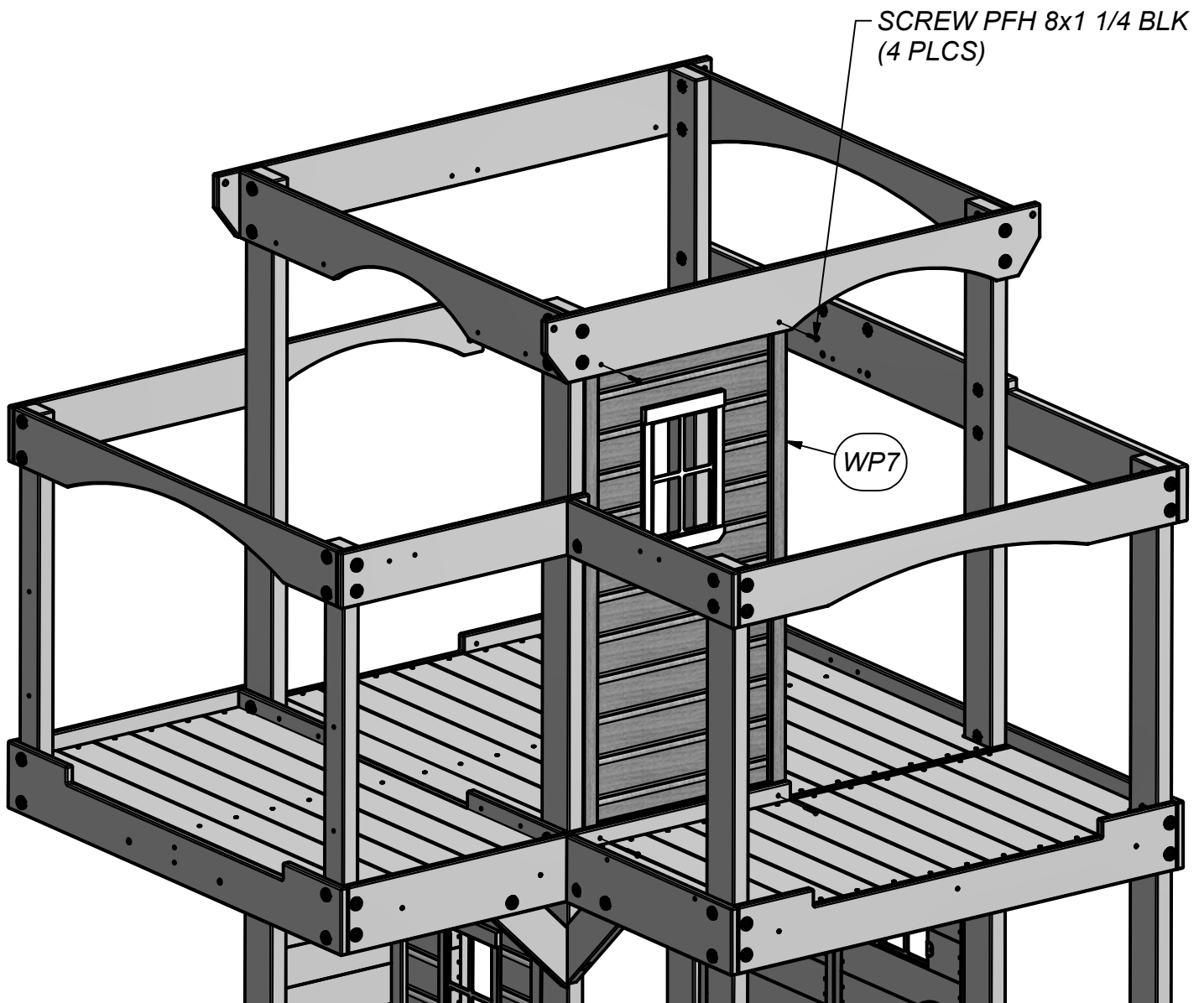
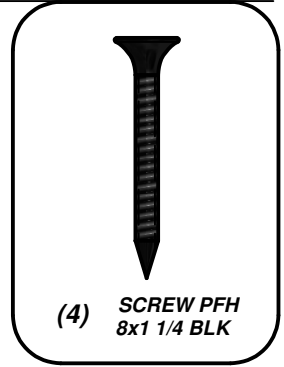

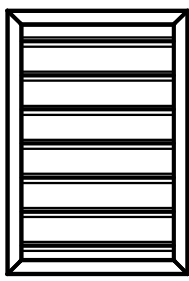

(2) WP3 - TOP RIGHT FRONT WALL PANEL - W2A02084  
1"x16 7/8"x24 5/8" (24x430x627)

**STEP 37**

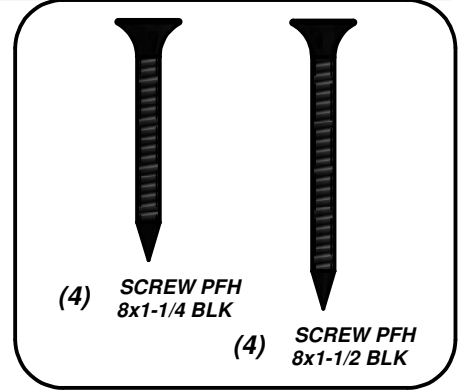
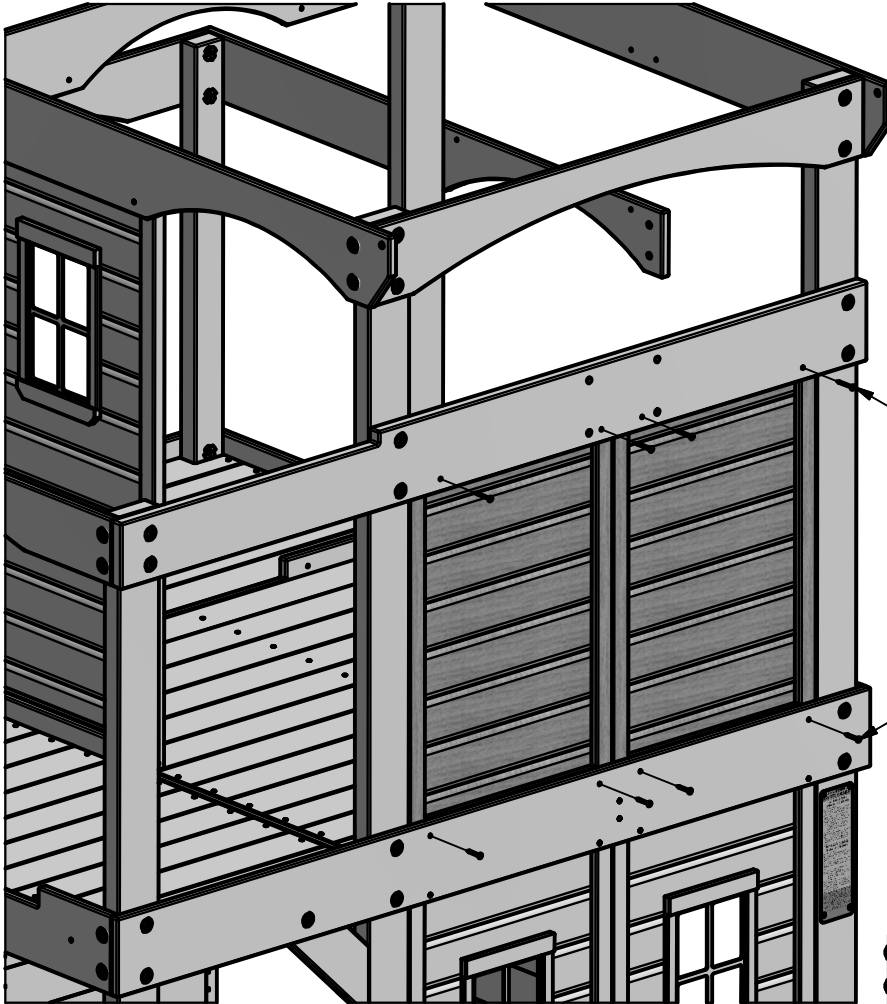

SCREW PFH 8x1-1/2 BLK  
(4 PLCS)

SCREW PFH 8x1-1/4 BLK  
(4 PLCS)

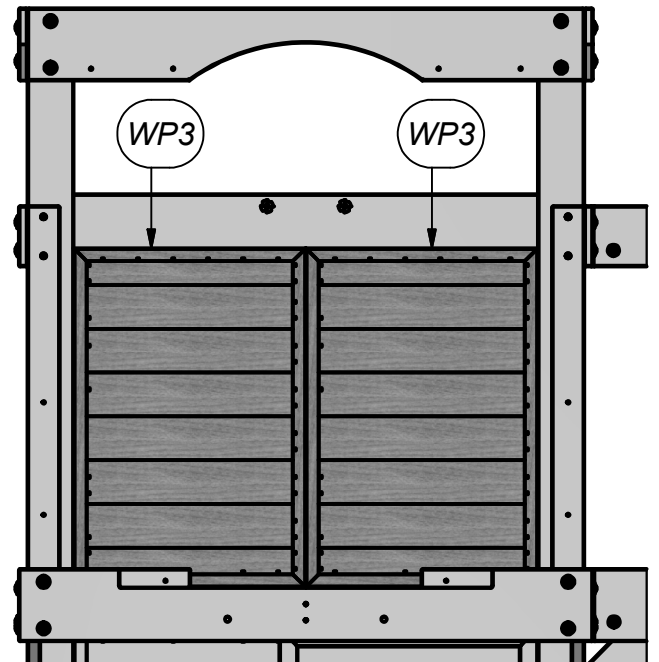

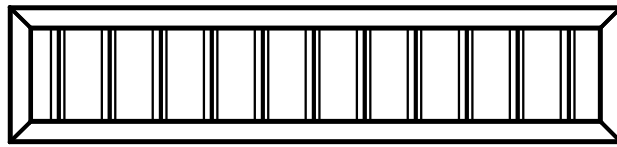

(2) WP8 - TOP LEFT WALL PANEL - W2A02089  
1"x11 3/4"x38 1/4" (24x214x971)

**STEP 38**

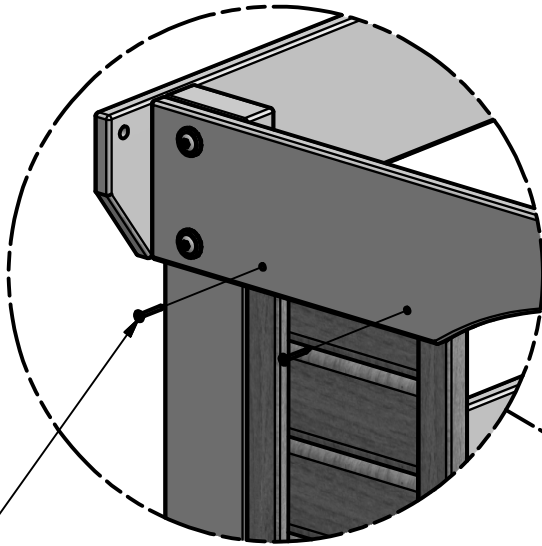
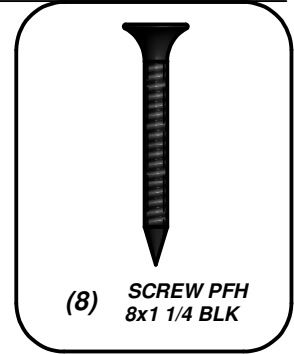

— SCREW PFH 8x1 1/4 BLK  
(4 PLCS)

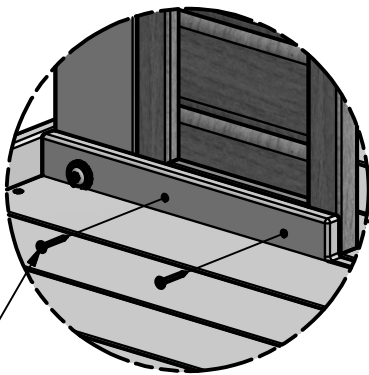

— SCREW PFH 8x1 1/4 BLK  
(4 PLCS)

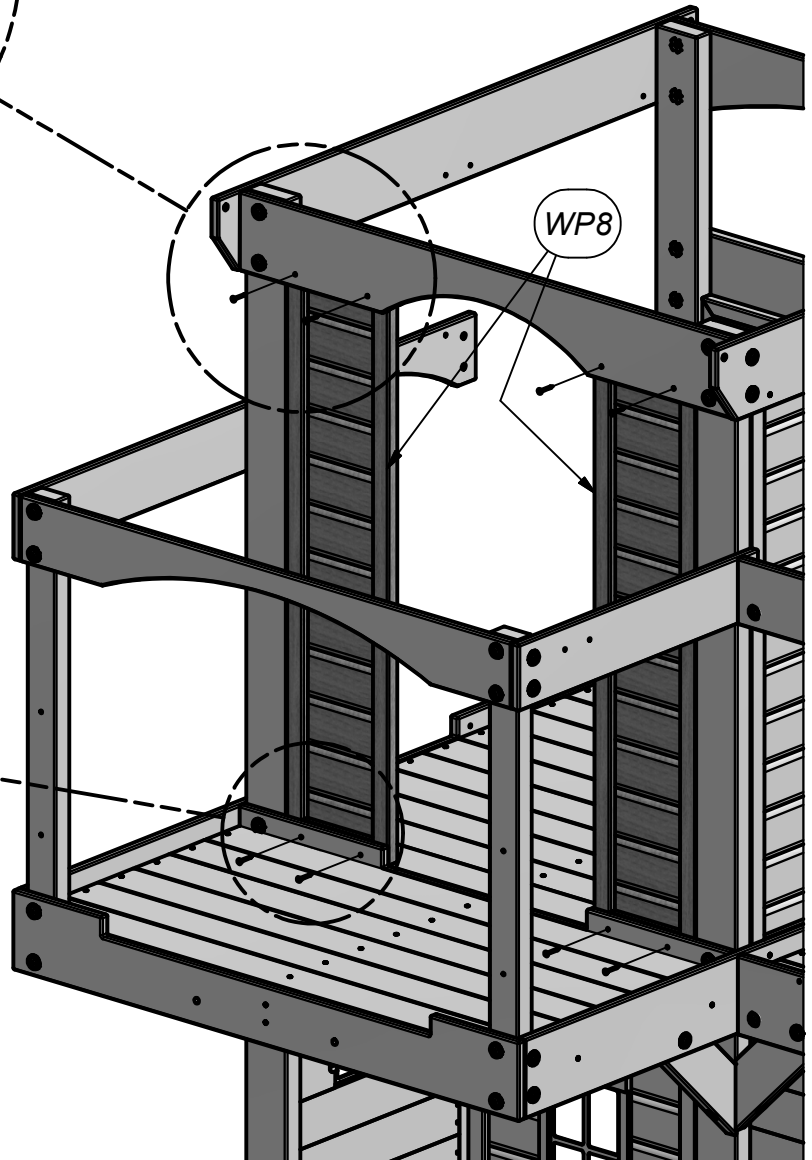

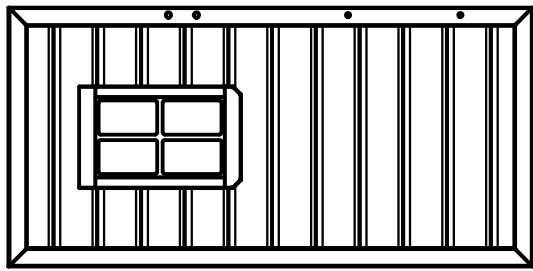

(1) WP5 - TOP LEFT REAR WALL PANEL - W2A02086  
1"x16 7/8"x46 1/2" (24x430x971)

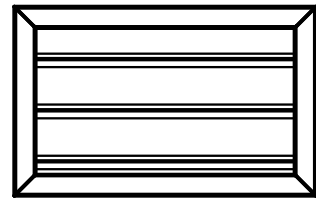

(1) WP6 - TOP REAR WALL PANEL - W2A02087  
1"x18 7/8"x11 3/4" (24x479x300)

**STEP 39**

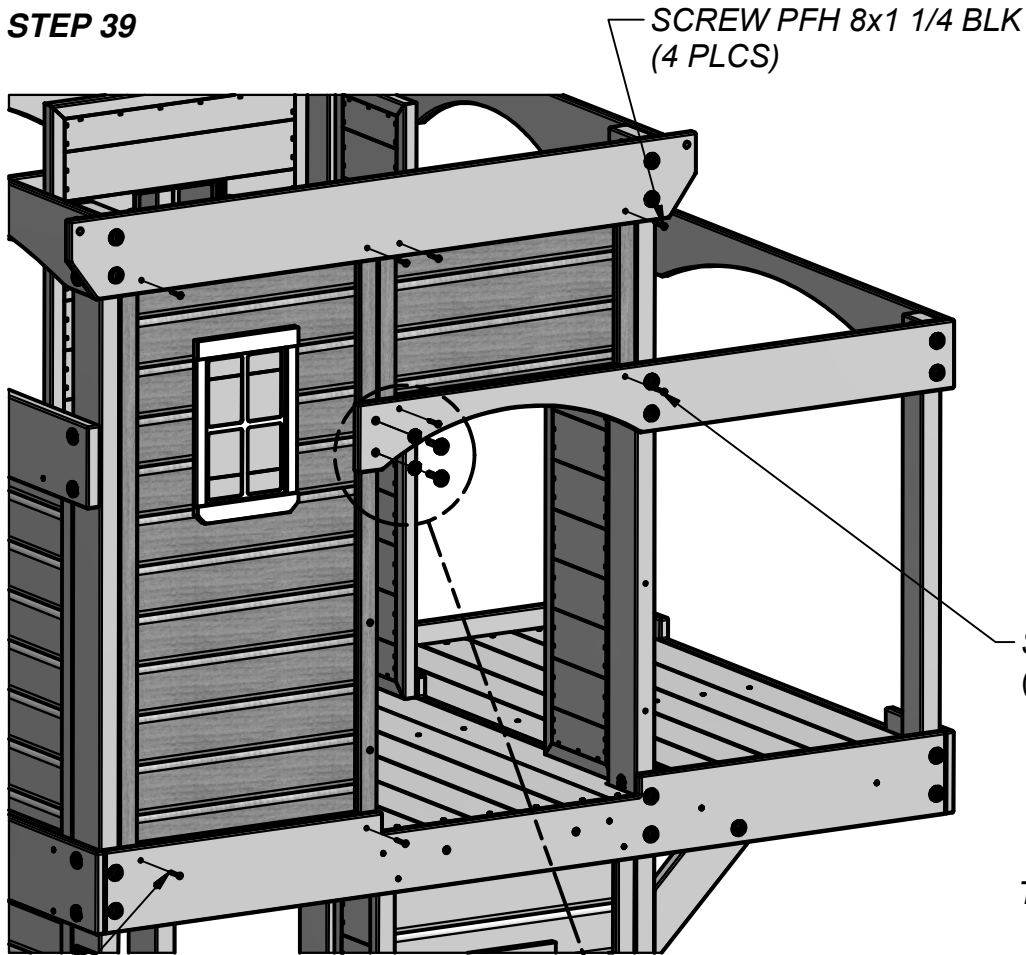

SCREW PFH 8x1 1/4 BLK  
(4 PLCS)

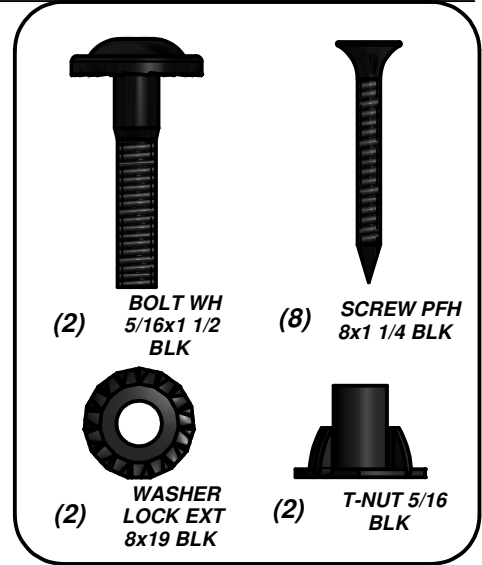

(2) BOLT WH  
5/16x1 1/2  
BLK

(8) SCREW PFH  
8x1 1/4 BLK

(2) WASHER  
LOCK EXT  
8x19 BLK

(2) T-NUT 5/16  
BLK

SCREW PFH 8x1 1/4 BLK  
(2 PLCS)

T-NUT 5/16 BLK  
(2 PLCS)

100 mm [3 7/8 in]

SCREW PFH 8x1 1/4 BLK  
(2 PLCS)

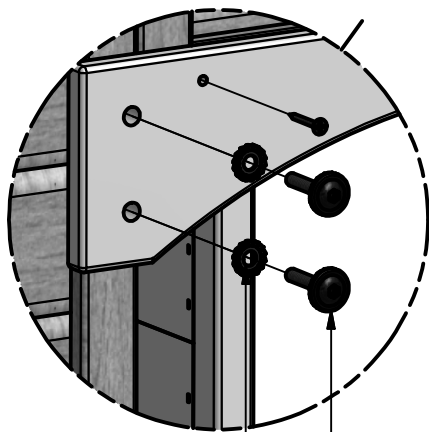

WASHER LOCK EXT 8x19 BLK  
(2 PLCS)

BOLT WH 5/16x1 1/2 BLK  
(2 PLCS)

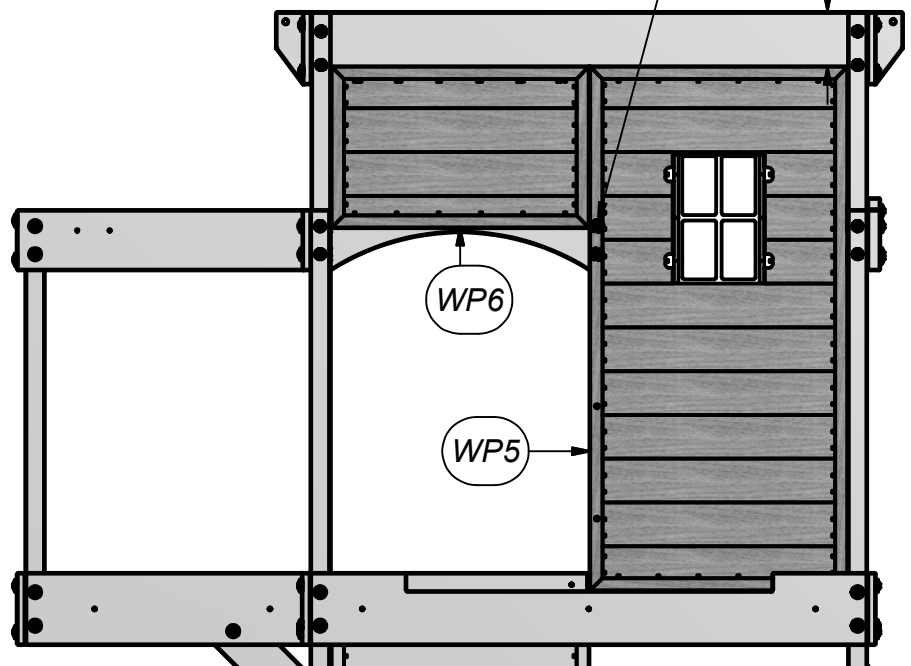

WP6

WP5



(8) N2 - PICKET - W4L07612  
5/8"x2 3/8"x24 3/4" (16x60x628)

**STEP 40**

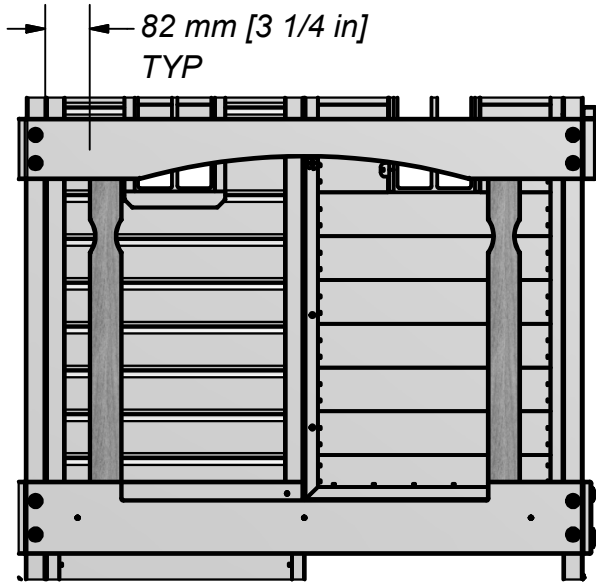

FRONT PICKET PLACEMENT

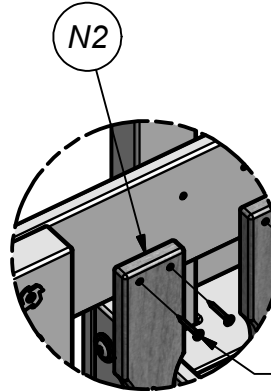

SCREW PFH 8x1 1/8  
(32 PLCS)

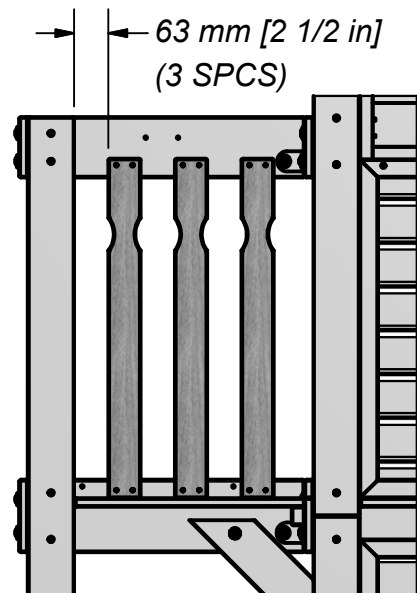
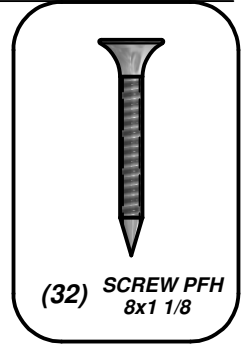

LEFT & RIGHT PICKET PLACEMENT

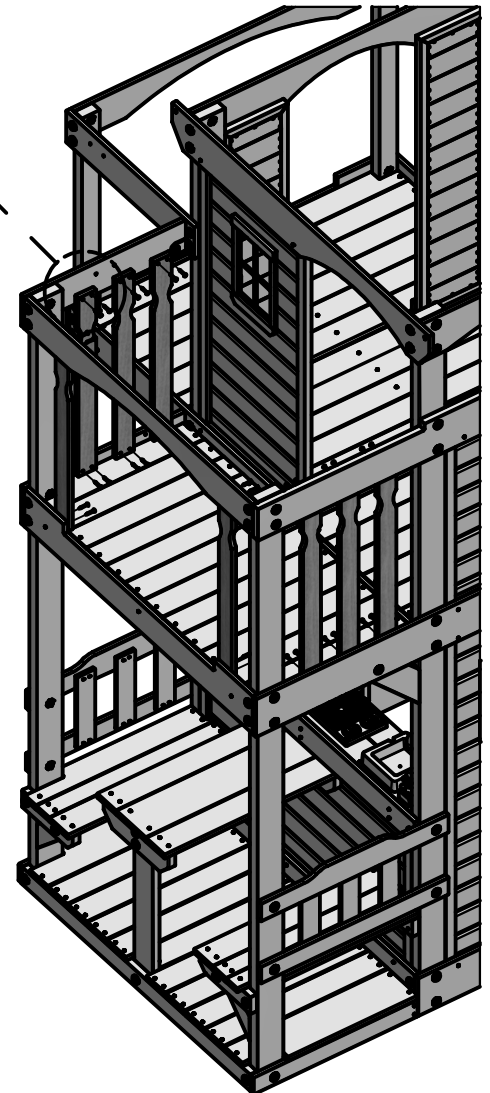

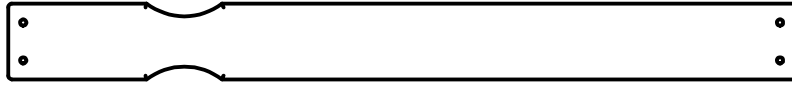

(10) **N2 - PICKET - W4L07612**  
5/8"x2 3/8"x24 3/4" (16x60x628)

**STEP 41**

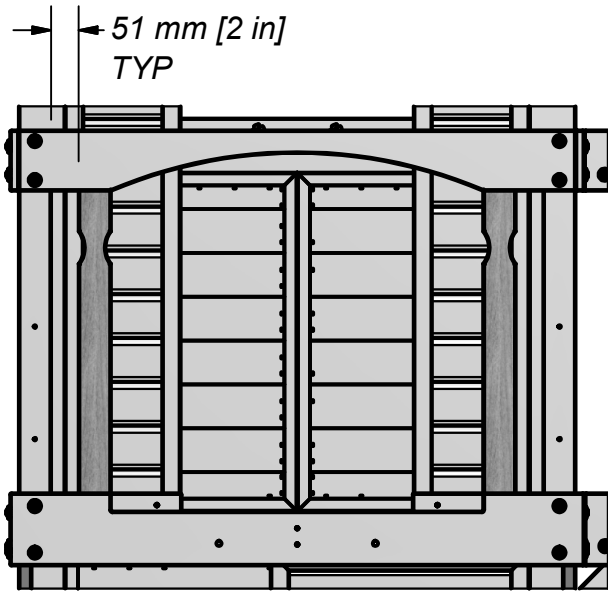

FRONT PICKET PLACEMENT

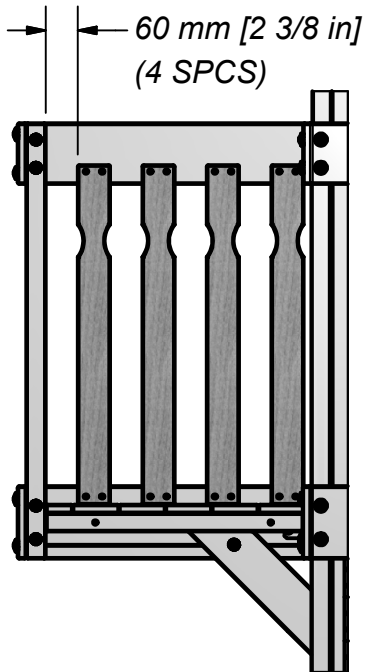

LEFT & RIGHT PICKET PLACEMENT

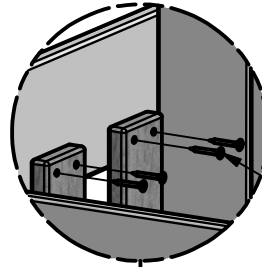

SCREW PFH 8x1 1/8  
(40 PLCS)

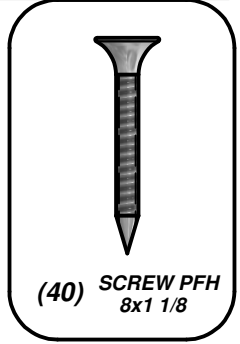

(40) **SCREW PFH**  
8x1 1/8

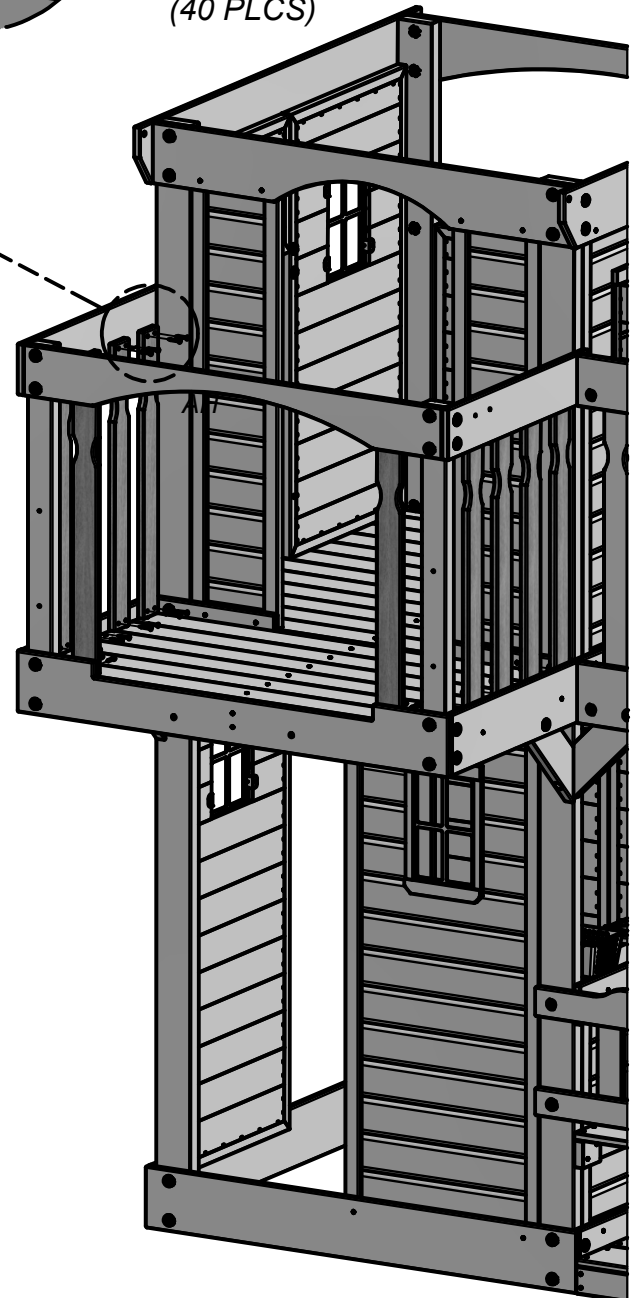

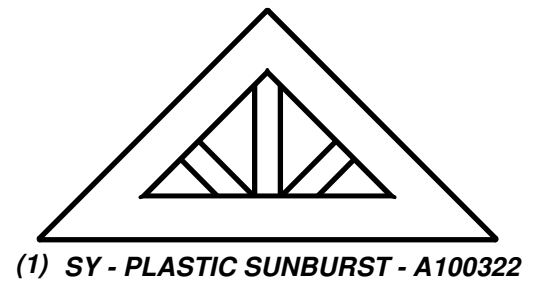
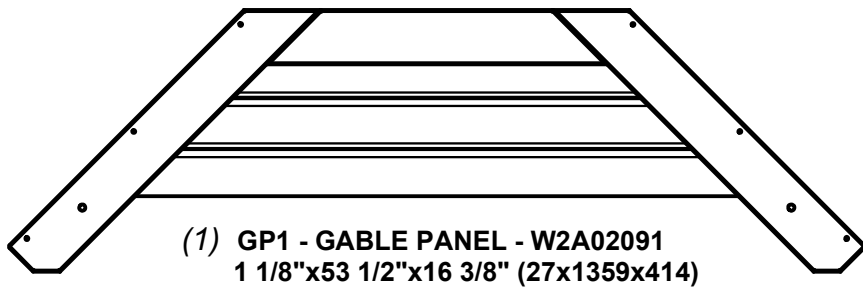

**STEP 42**

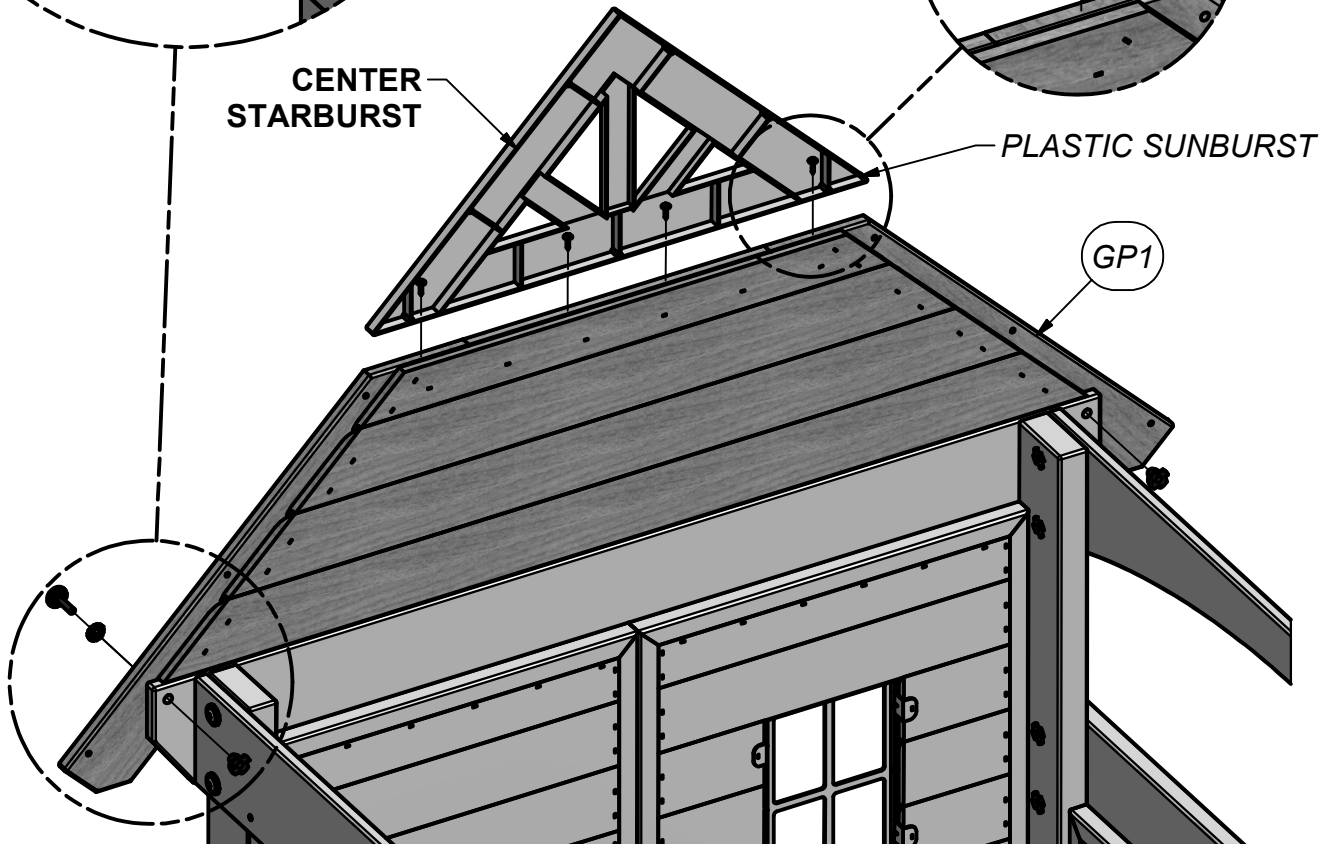
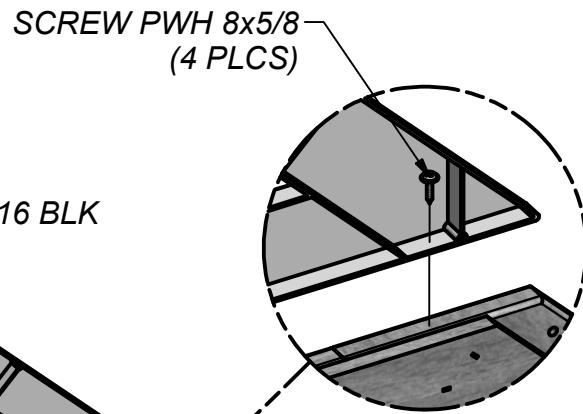
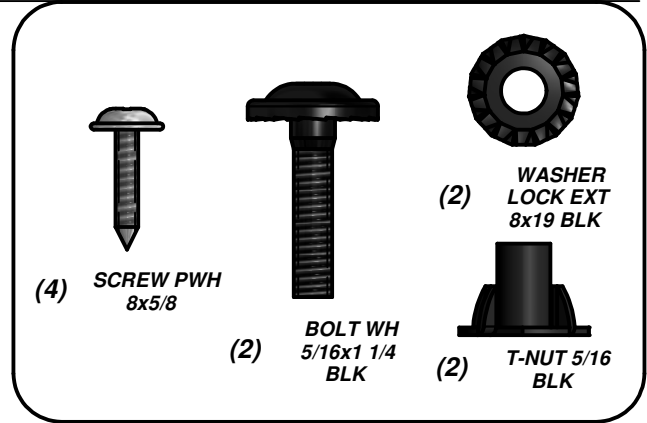
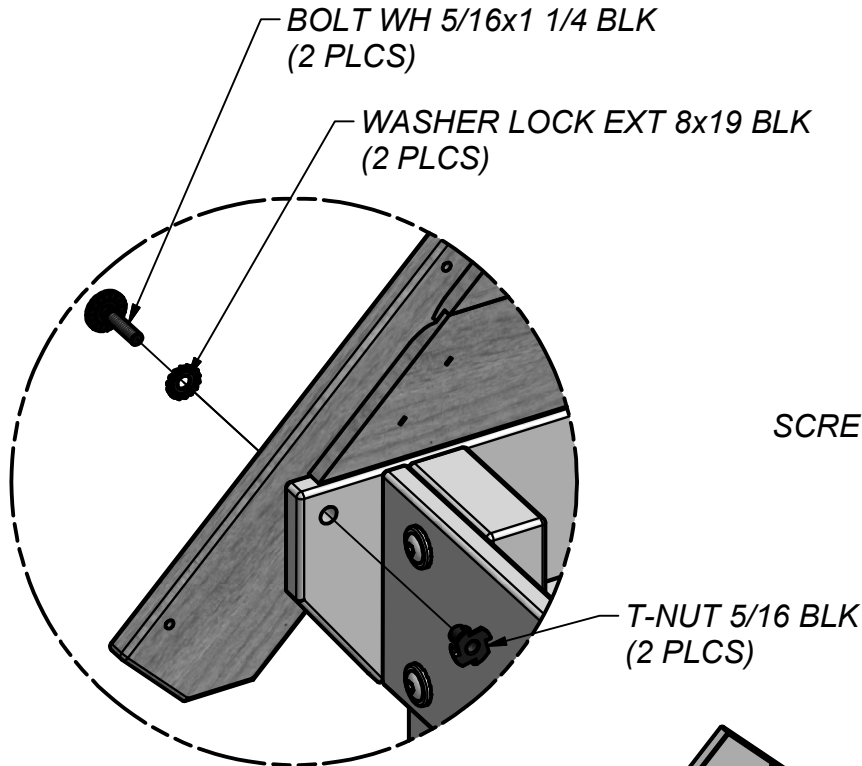

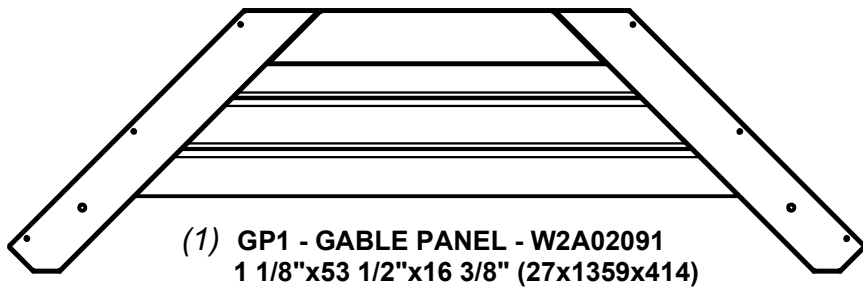

(1) GP1 - GABLE PANEL - W2A02091  
1 1/8"x53 1/2"x16 3/8" (27x1359x414)

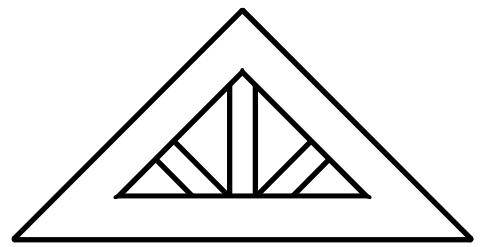

(1) SY - PLASTIC SUNBURST - A100322

**STEP 43**

BOLT WH 5/16x1 1/4 BLK  
(2 PLCS)

WASHER LOCK EXT 8x19 BLK  
(2 PLCS)

(4) SCREW PWH  
8x5/8

(2) BOLT WH  
5/16x1 1/4  
BLK

(2) WASHER  
LOCK EXT  
8x19 BLK

(2) T-NUT 5/16  
BLK

T-NUT 5/16 BLK  
(2 PLCS)

SCREW PWH 8x5/8  
(4 PLCS)

CENTER  
SUNBURST

PLASTIC SUNBURST

GP1

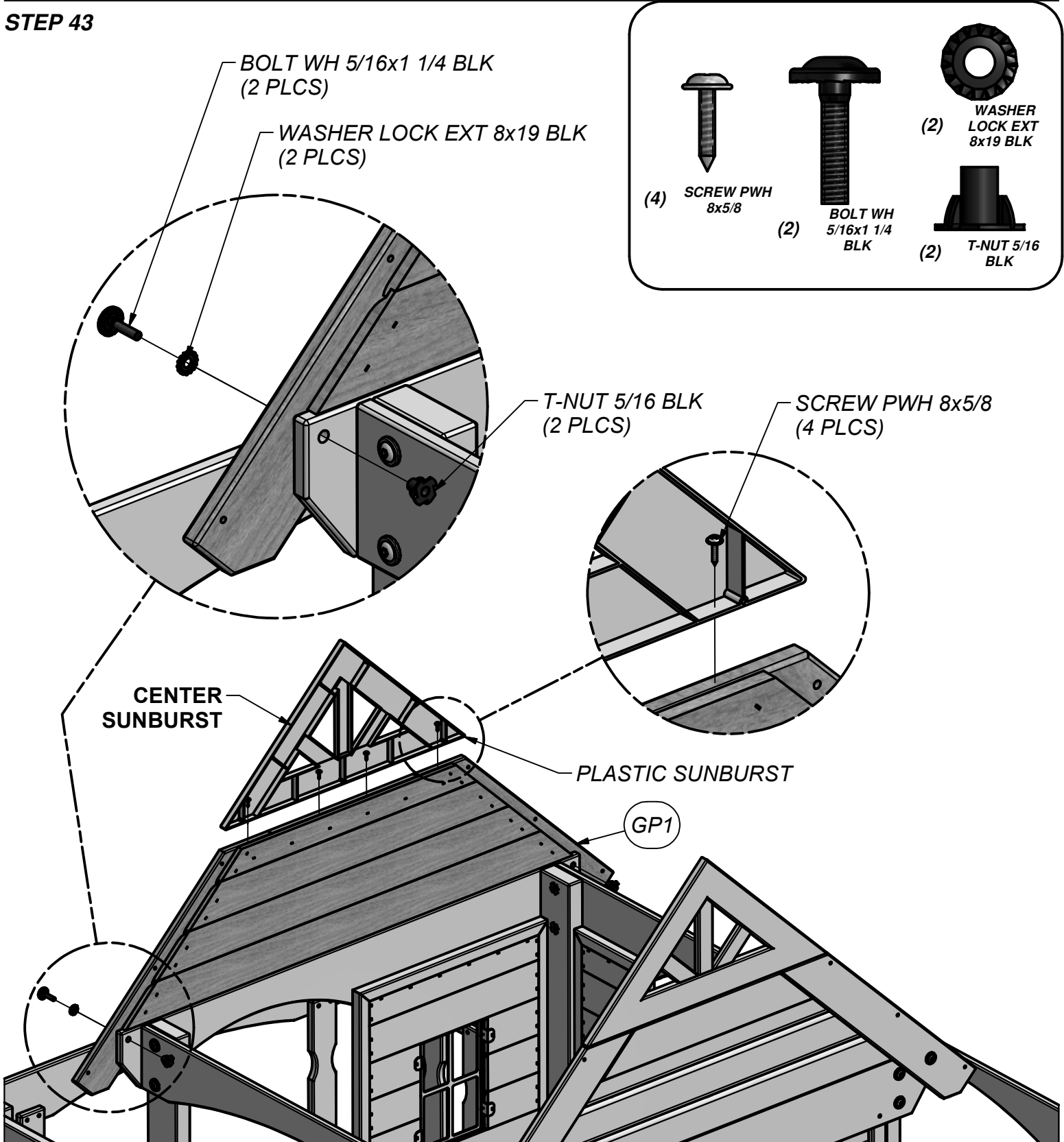

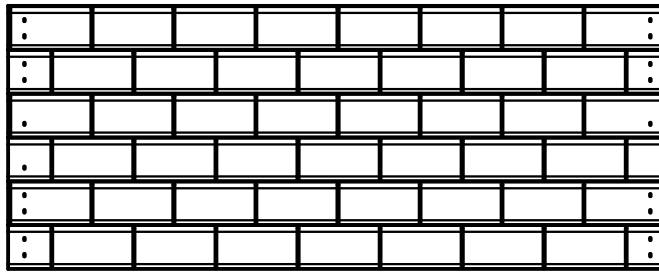

(2) RP2 - TOP ROOF PANEL - W2A02093  
1 3/8"x48"x19 1/8" (35x1220x486)

STEP 44

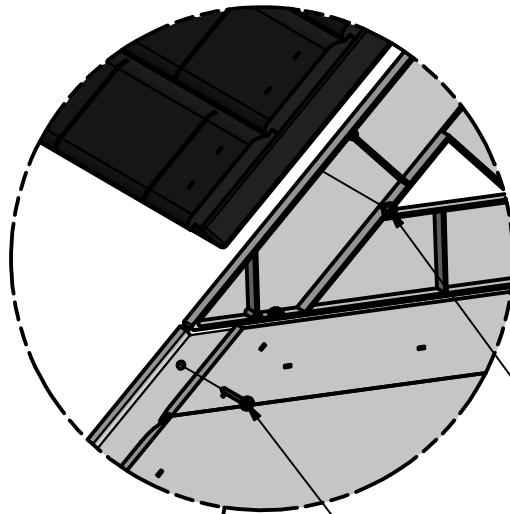
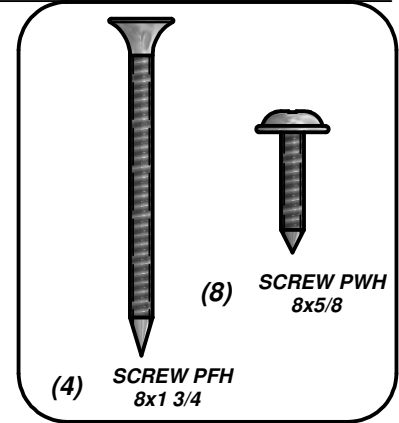

SCREW PWH 8x5/8  
(8 PLCS)

SCREW PFH 8x1 3/4  
(4 PLCS)

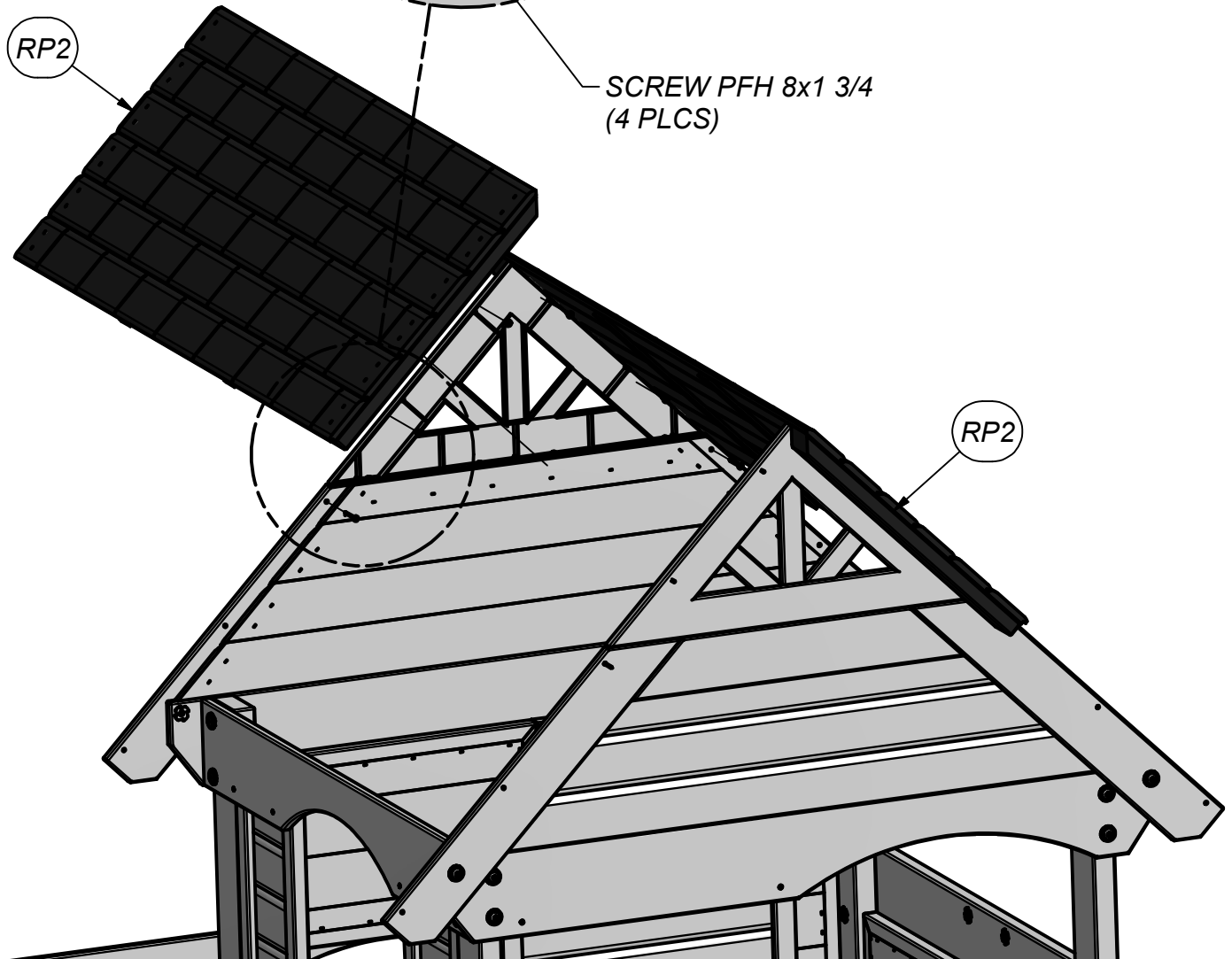

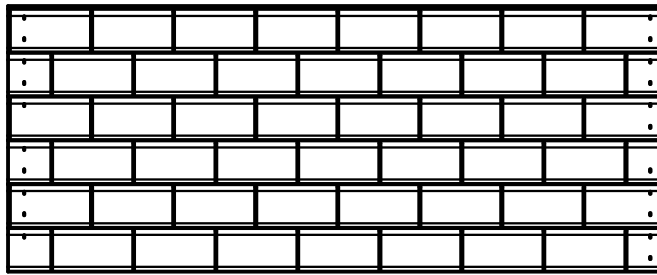

(2) RP1 - BOTTOM ROOF PANEL - W2A02092  
1 3/8"x48"x19 3/8" (35x1220x491)

**STEP 45**

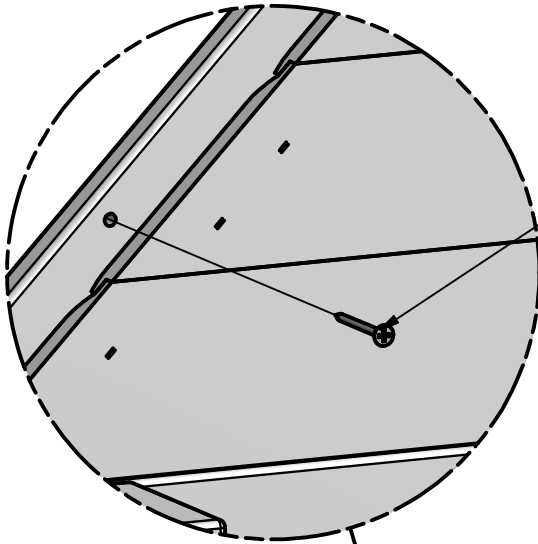

SCREW PFH 8x1 3/4  
(8 PLCS)

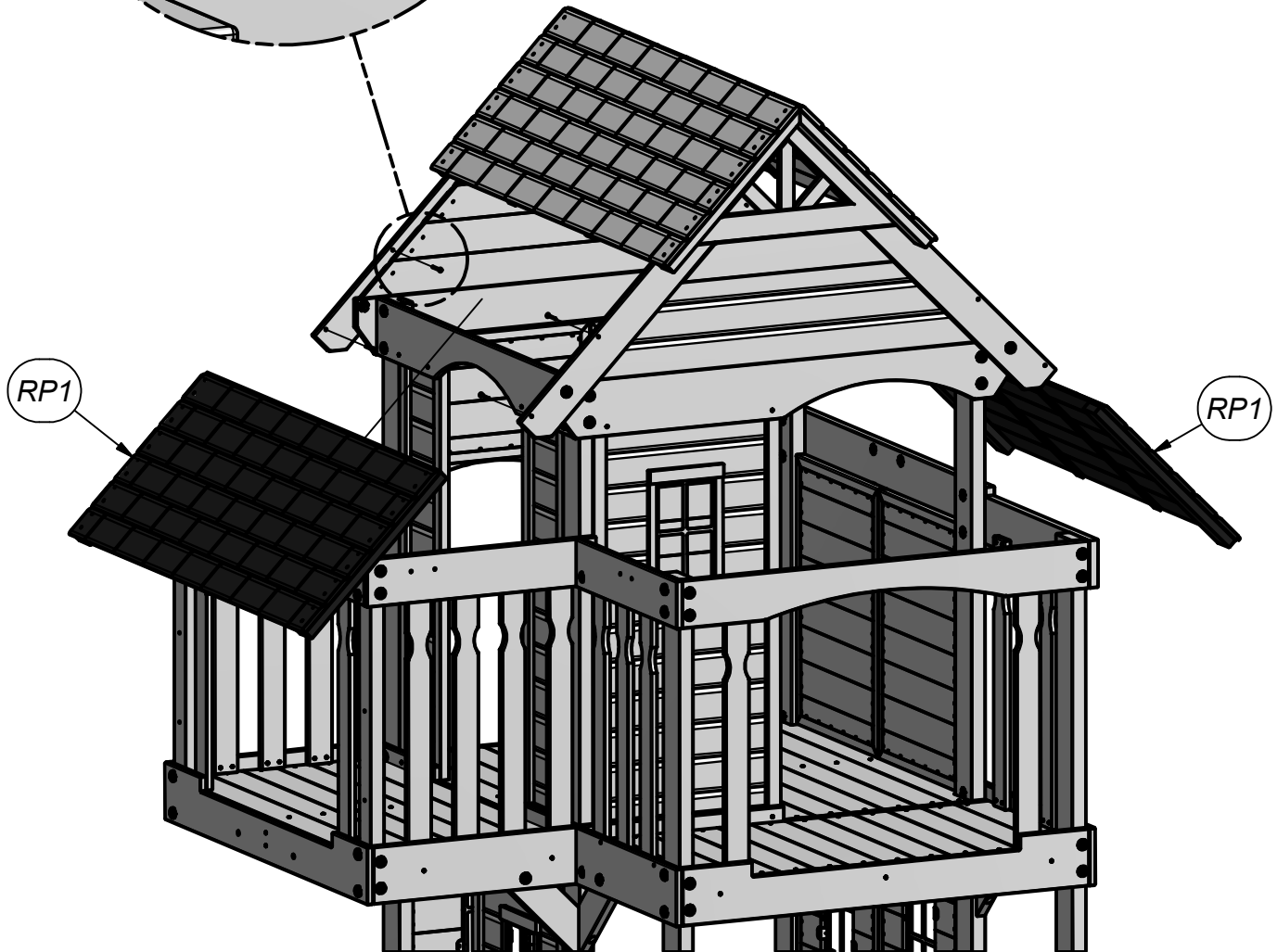
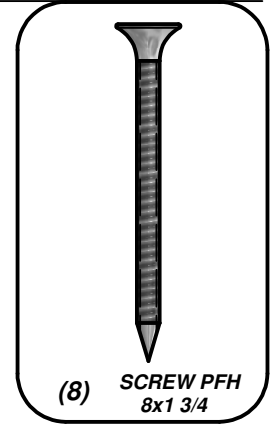

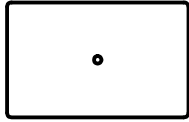

(1) **E10 - MOUNTING BLOCK - W4L07615**  
 1 3/8"x3"x4 3/4" (36x76x120)

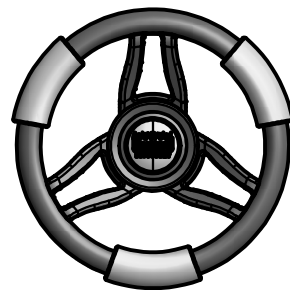

(1) **LP - STEERING WHEEL - A100105**

**STEP 46**

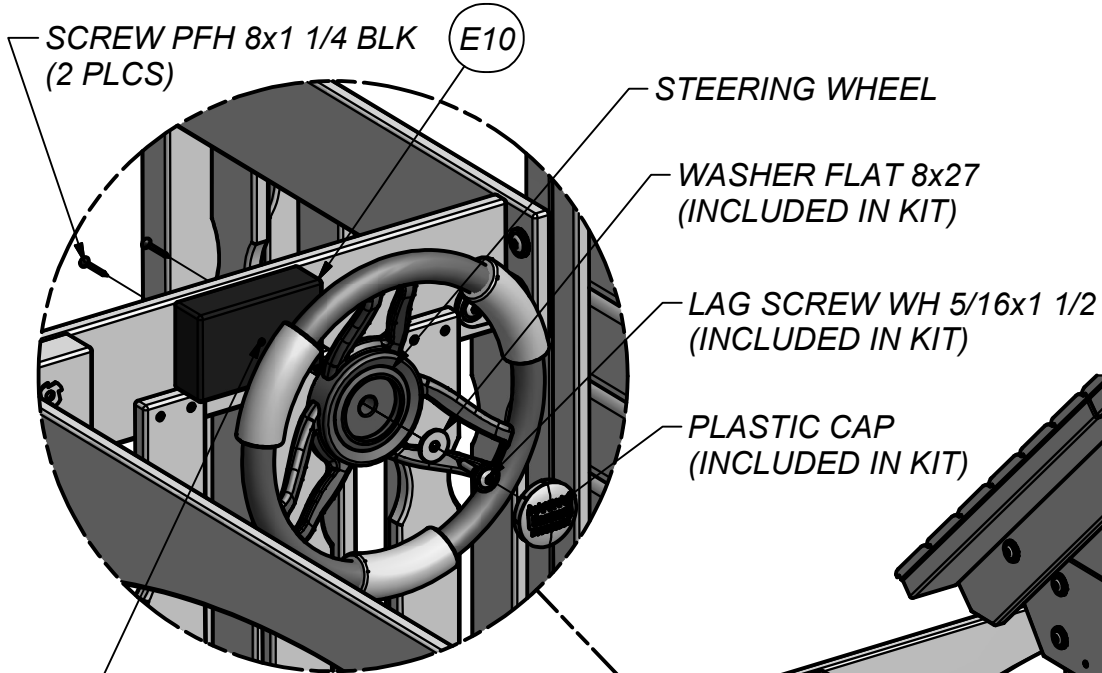
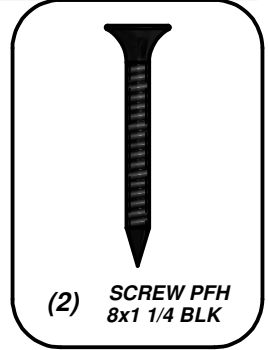

NOTE HOLE LOCATION FOR PROPER ORIENTATION.

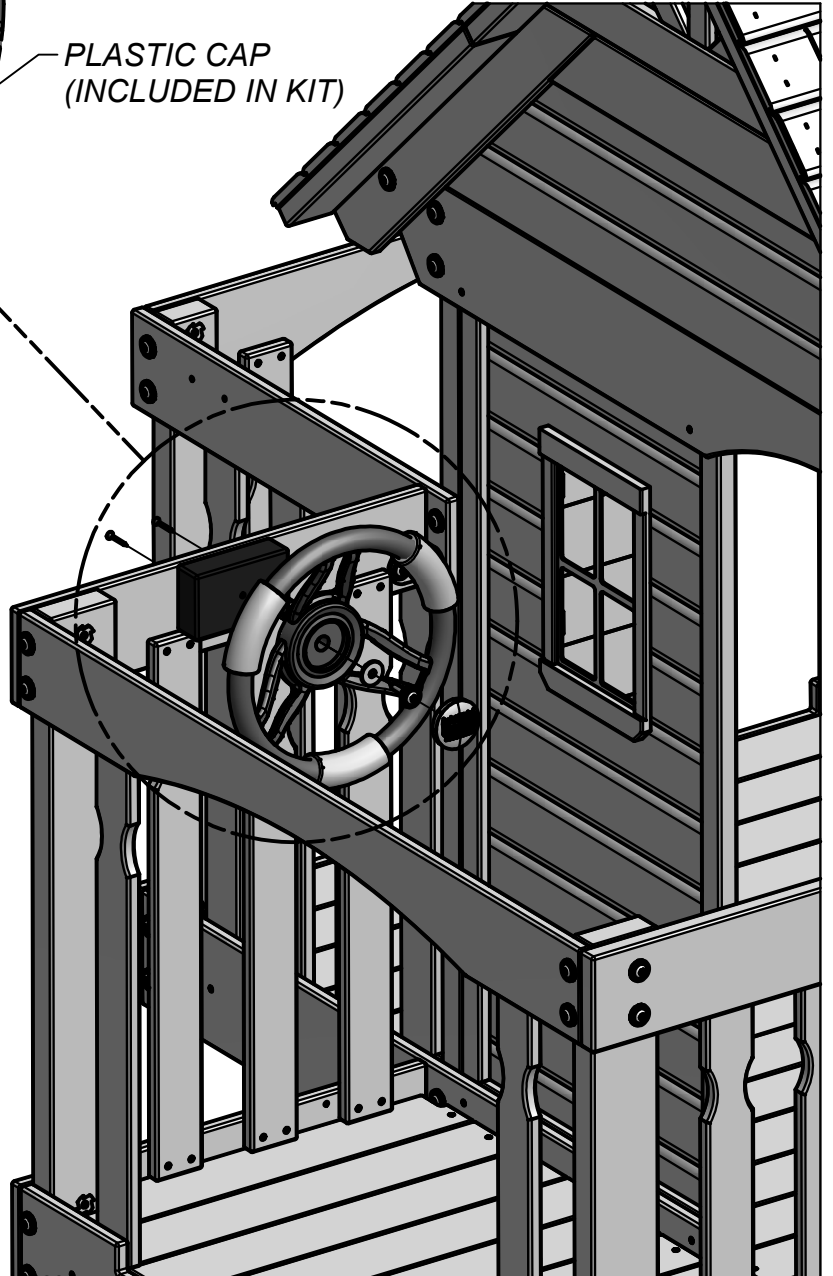

THIS HOLE FACES THE  
RAIL IN THIS STEP.

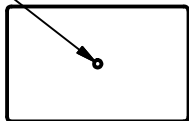

- (1) **E10 - MOUNTING BLOCK - W4L07615**  
1 3/8"x3"x4 3/4" (36x76x120)

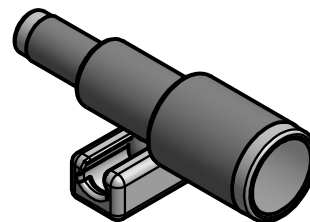

- (1) **LN - Telescope - A6P00096**

**STEP 47**

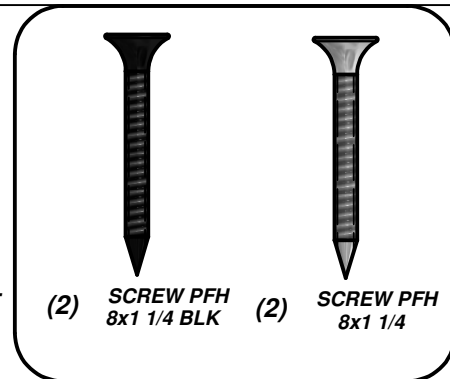
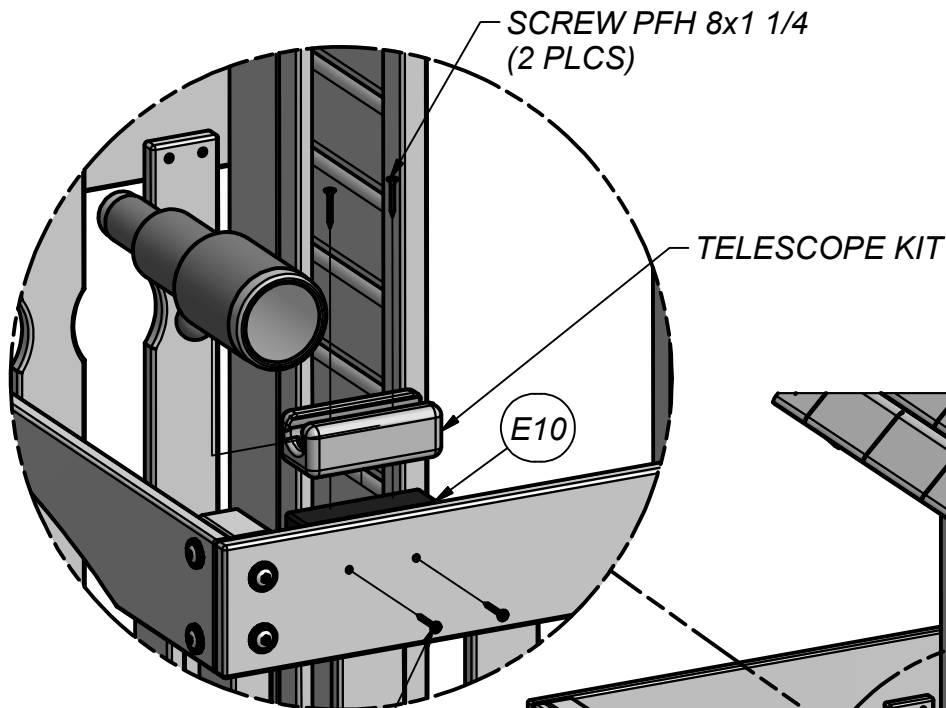

- SCREW PFH 8x1 1/4 BLK  
(2 PLCS)

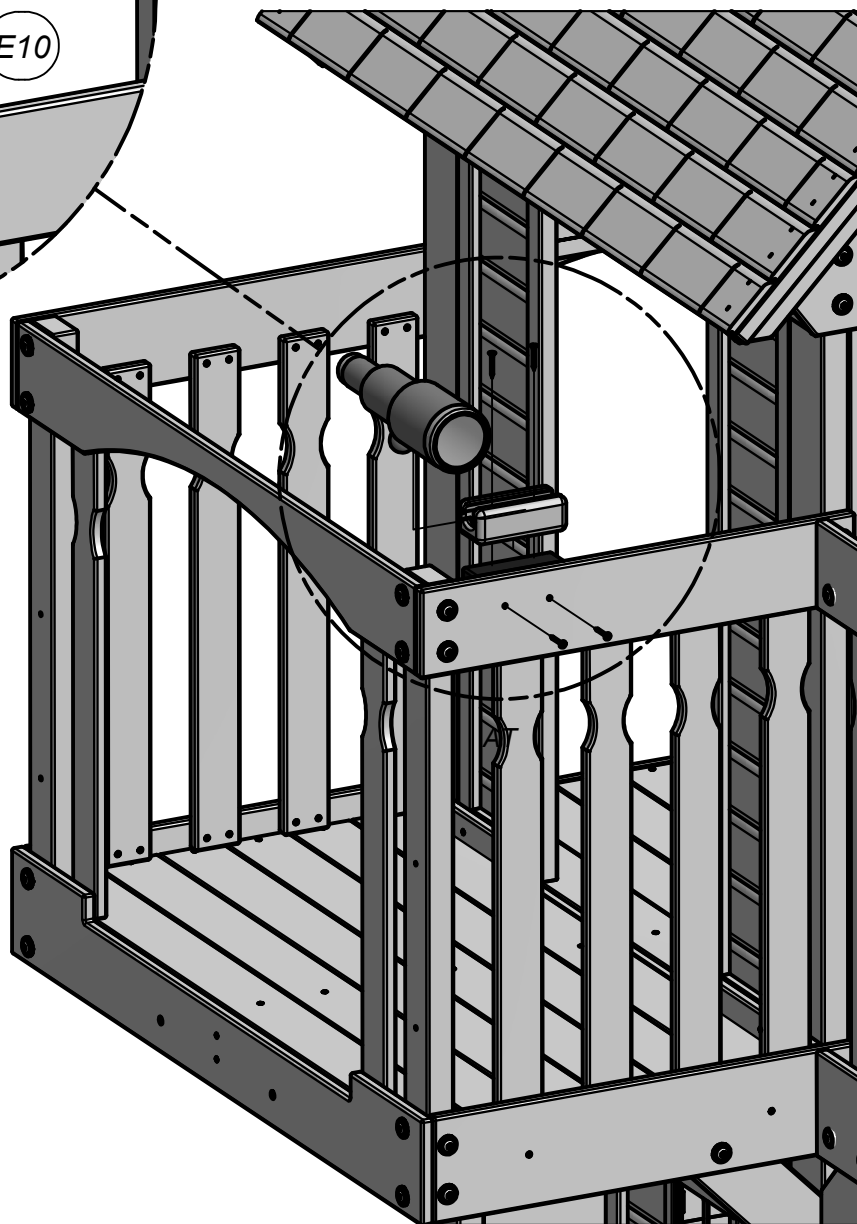

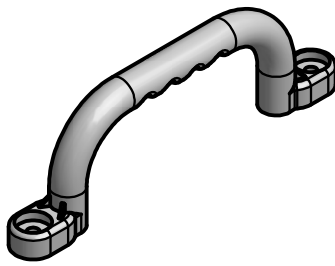

(2) EA - HAND GRIP YELLOW PLASTIC - A100043

**STEP 48**

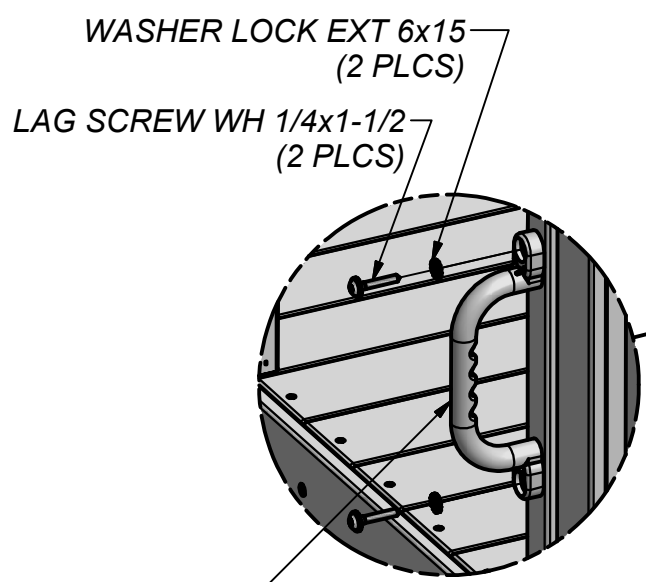
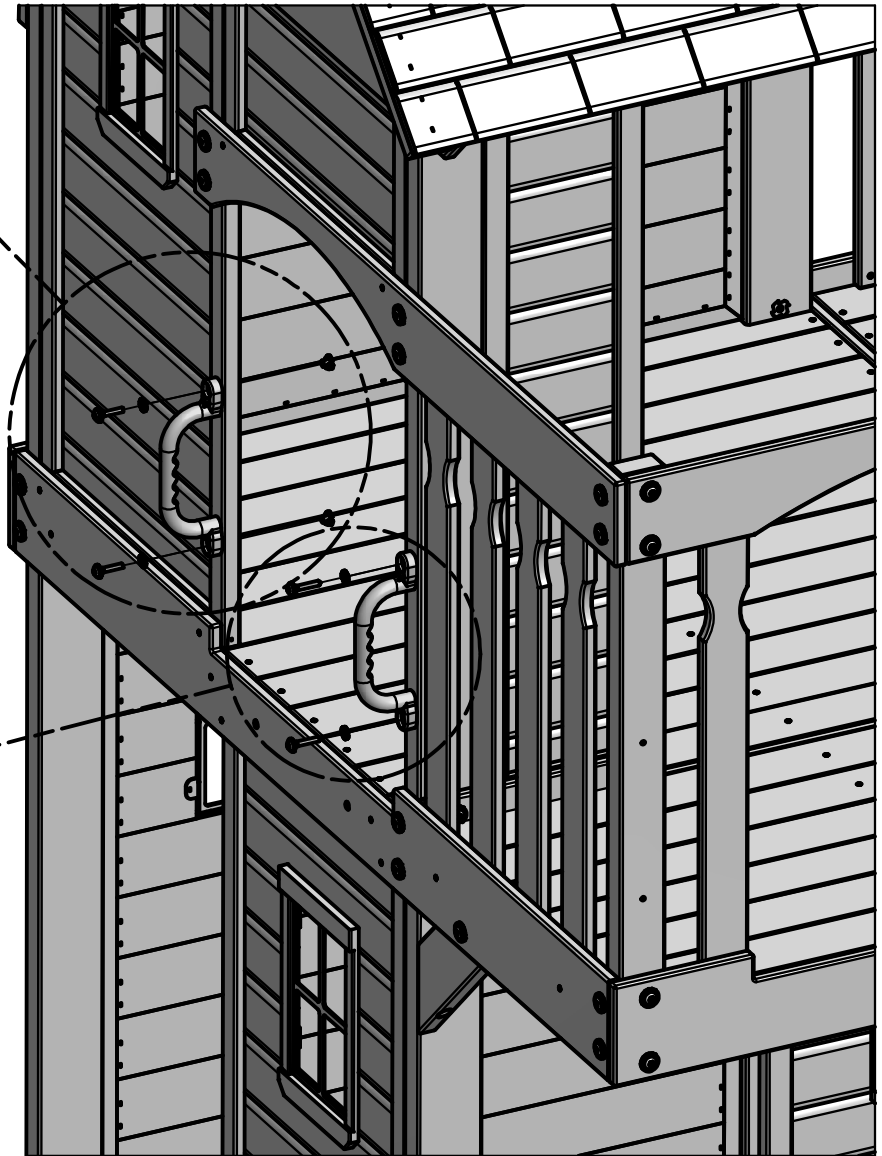
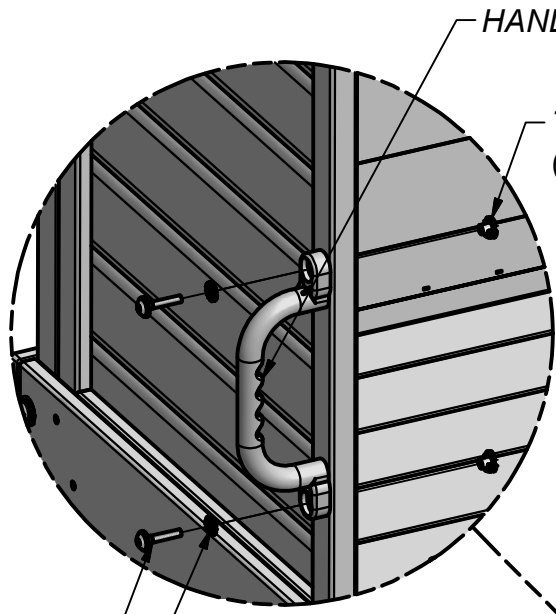
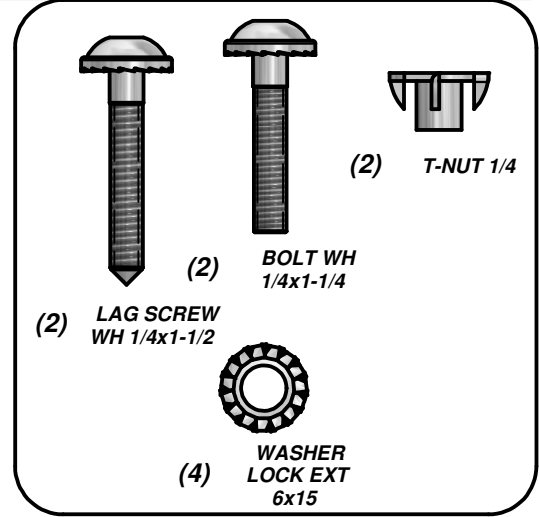

HAND GRIP YELLOW PLASTIC

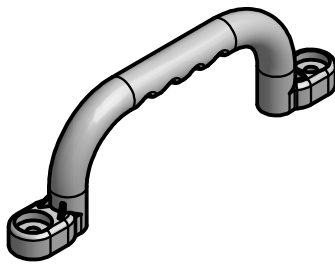

(2) EA - HAND GRIP YELLOW PLASTIC - A100043

**STEP 49**

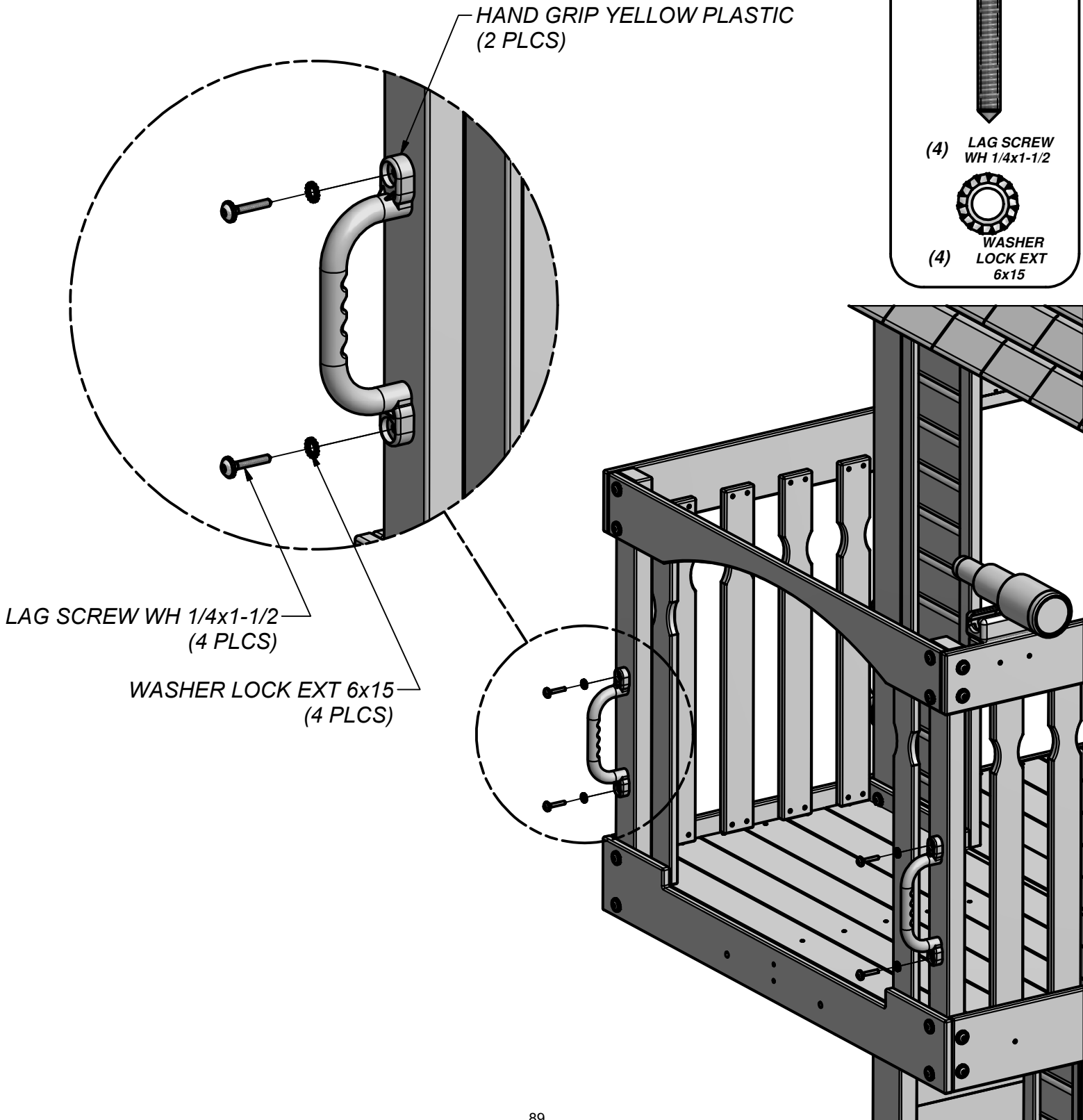

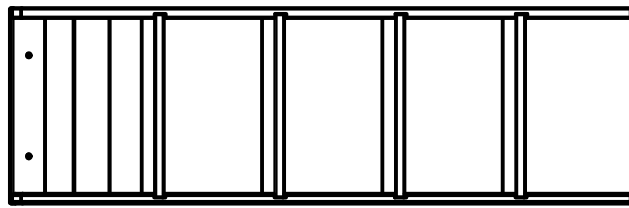

(1) LADDER ASSEMBLY

**STEP 50**

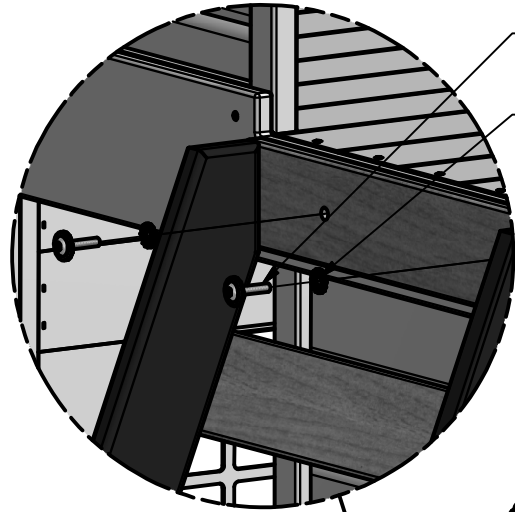

- BOLT WH 5/16x1 1/4 BLK  
(2 PLCS)
- WASHER LOCK EXT 8x19 BLK  
(2 PLCS)



(2) BOLT WH  
5/16x1 1/4  
BLK



(2) WASHER  
LOCK EXT  
8x19 BLK

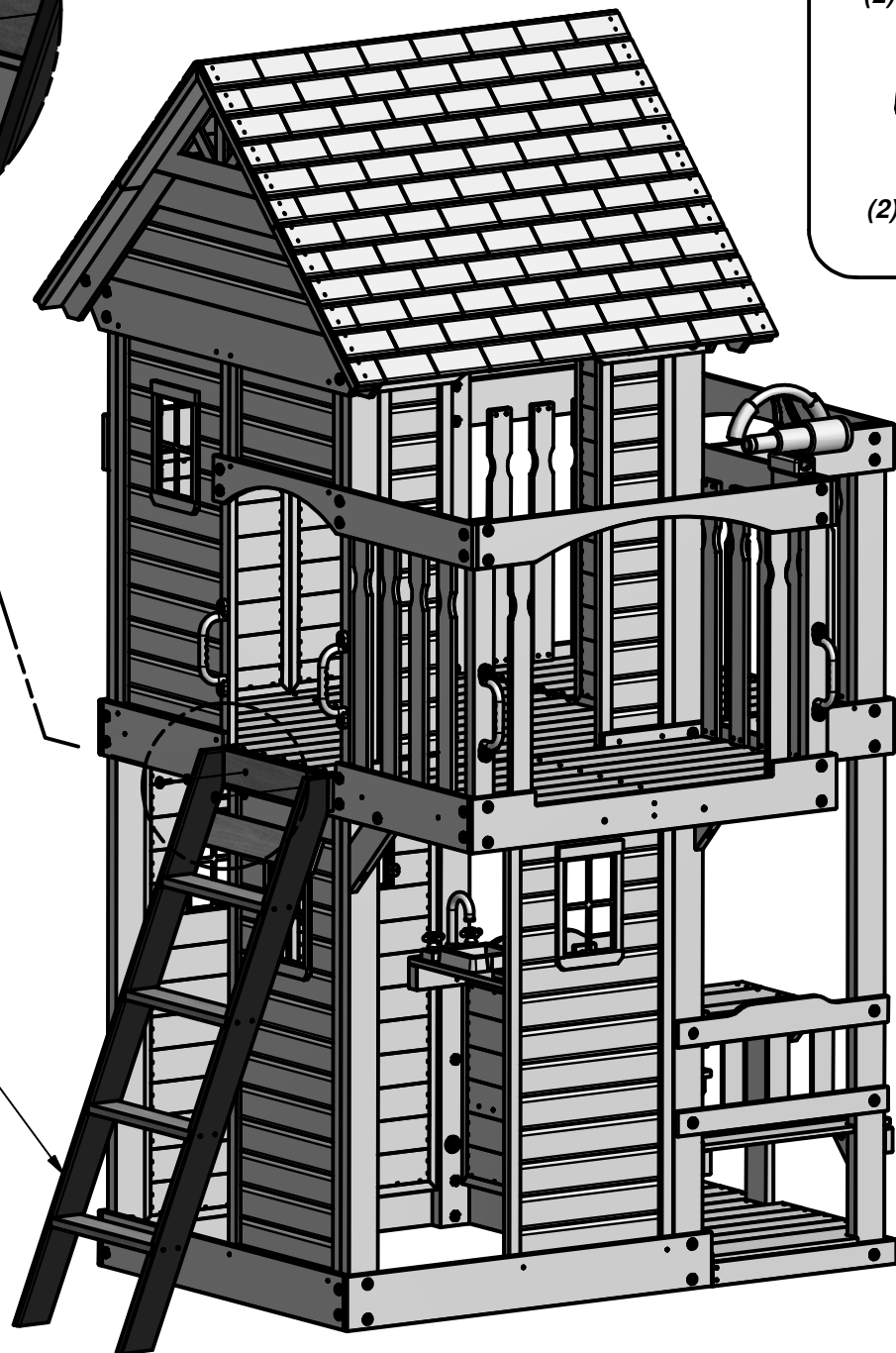

LADDER ASSEMBLY

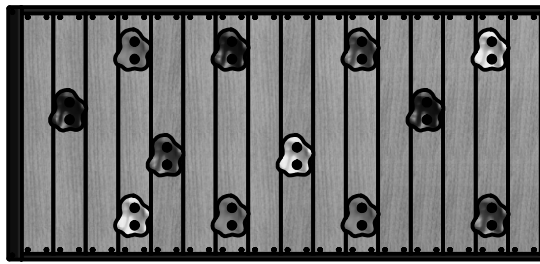

(1) ROCKWALL ASSEMBLY

**STEP 51**

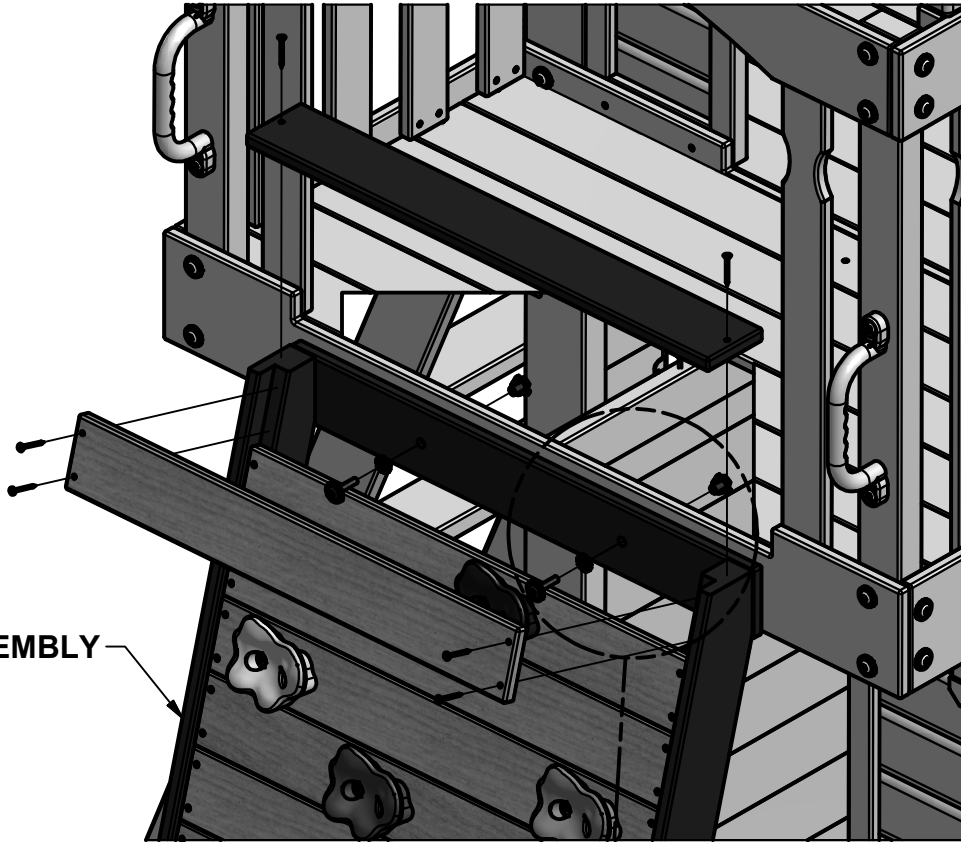

ROCKWALL ASSEMBLY



(2) BOLT WH  
5/16x1 1/4  
BLK



(2) WASHER  
LOCK EXT  
8x19 BLK



(2) T-NUT 5/16  
BLK

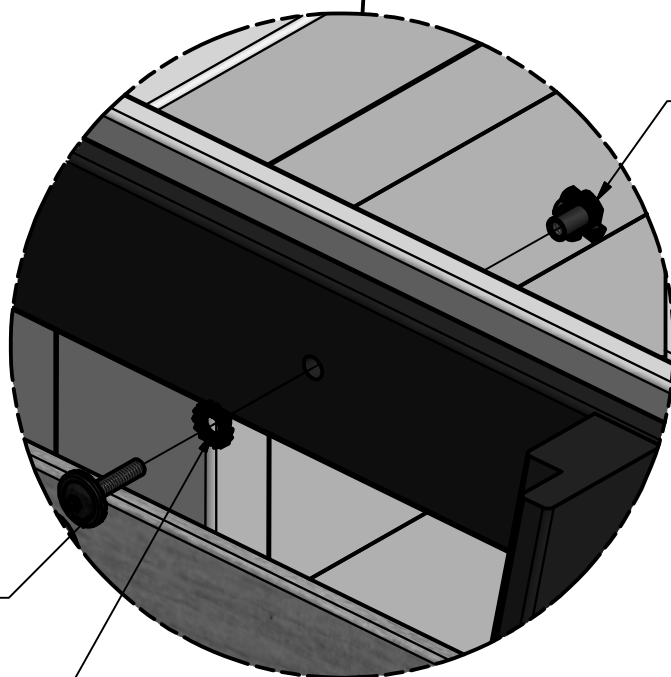

T-NUT 5/16 BLK  
(2 PLCS)

BOLT WH 5/16x1 1/4 BLK  
(2 PLCS)

WASHER LOCK EXT 8x19 BLK  
(2 PLCS)

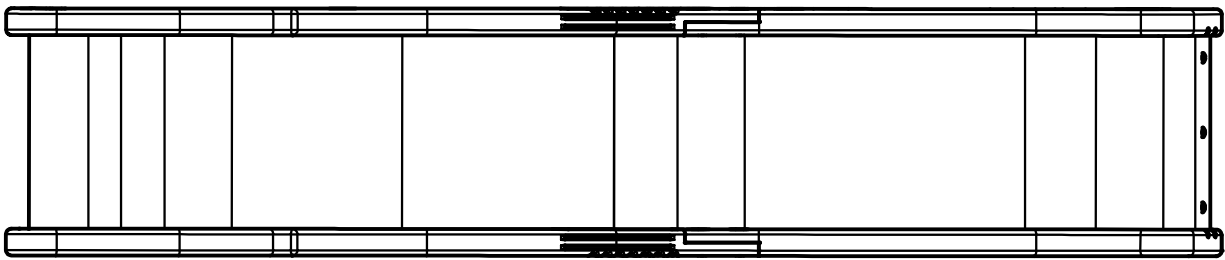

(1) 10' SLIDE ASSEMBLY

**STEP 52**

USE A 7/16" DRILL BIT.

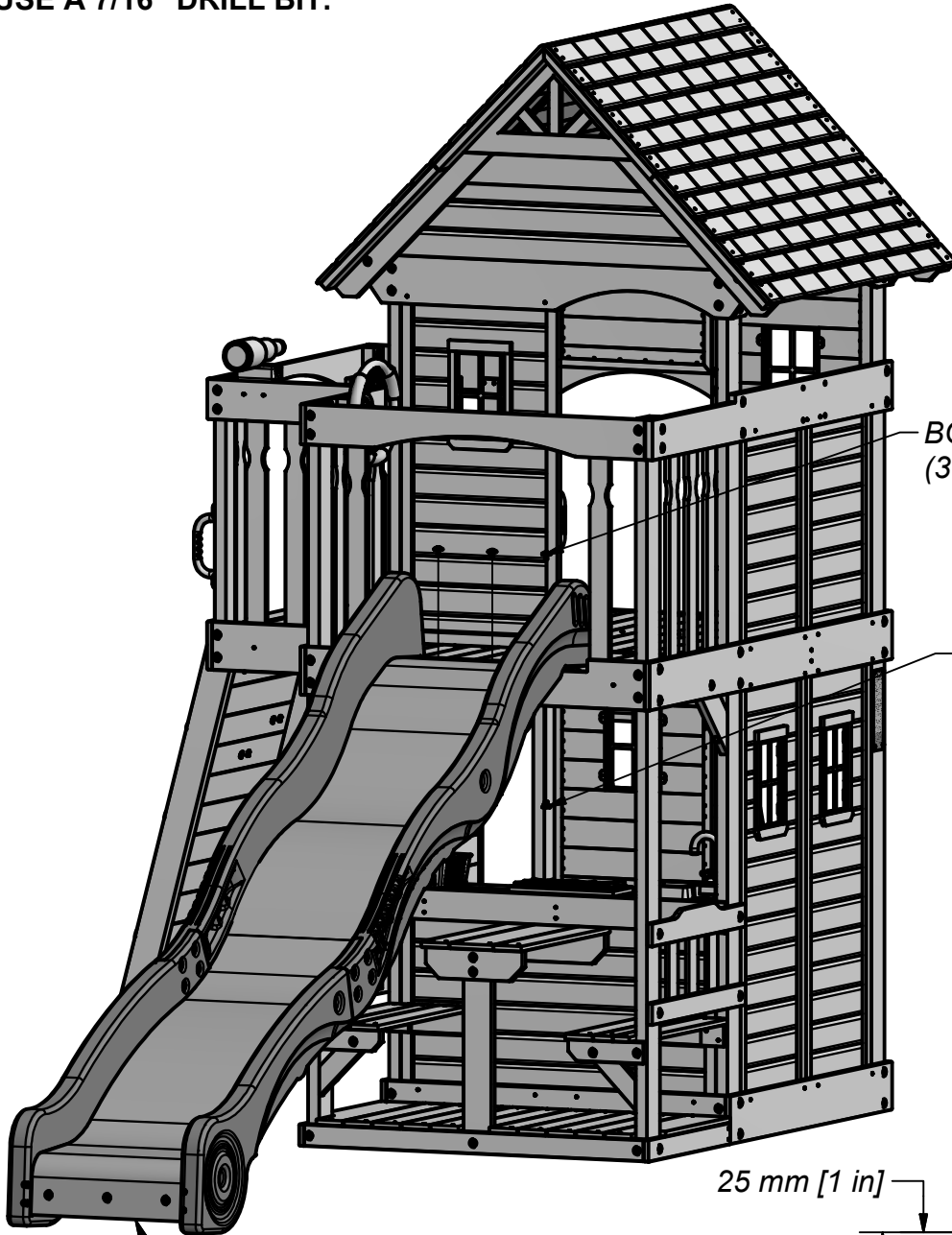
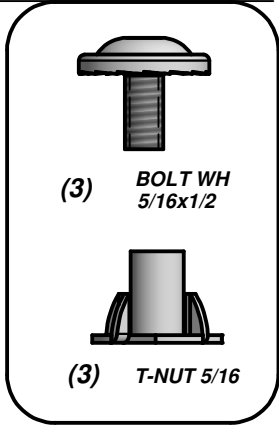

BOLT WH 5/16x1/2  
(3 PLCS)

T-NUT 5/16  
(3 PLCS)

10' SLIDE ASSEMBLY

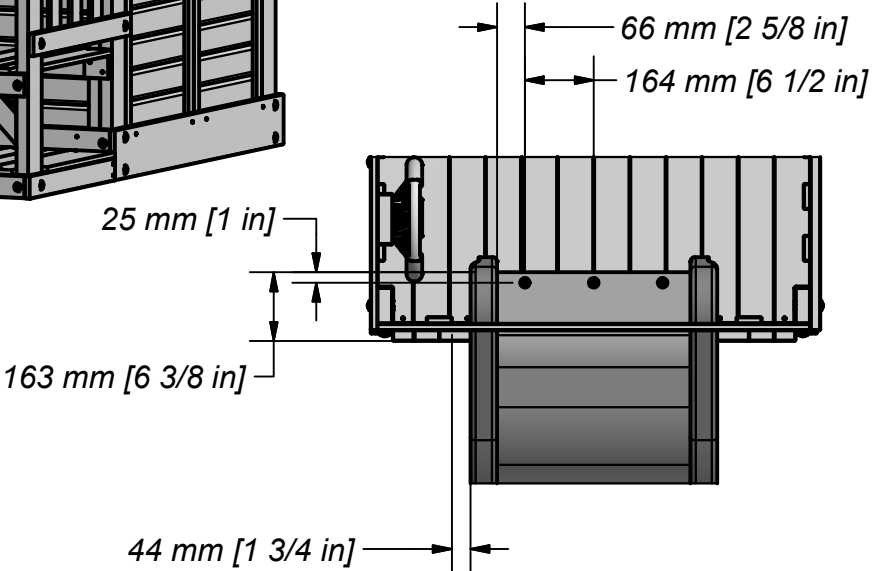

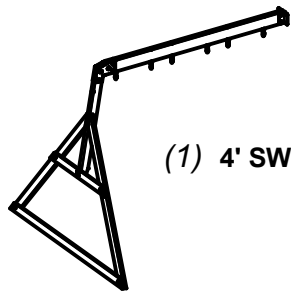

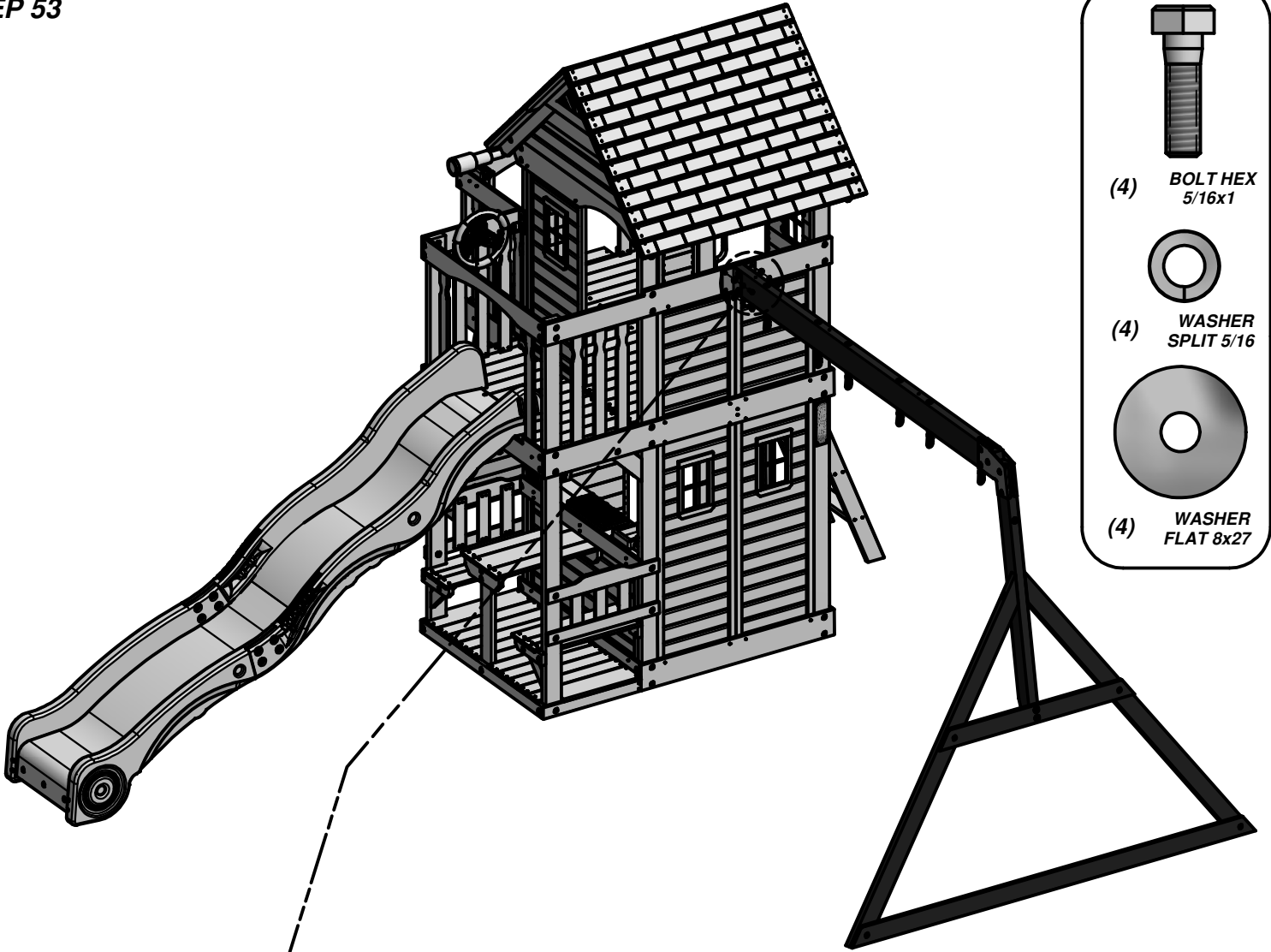

(1) 4' SWING BEAM ASSEMBLY

**STEP 53**



-   
(4) BOLT HEX 5/16x1
-   
(4) WASHER SPLIT 5/16
-   
(4) WASHER FLAT 8x27

- WASHER FLAT 8x27  
(4 PLCS)
- WASHER SPLIT 5/16  
(4 PLCS)
- BOLT HEX 5/16x1  
(4 PLCS)

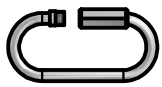

(6) FA - QUICK LINK - A100069



(2) DP - SWING SEAT GREEN - A100027



(1) - TRAPEZE - A6P00034



(2) KN - CHAIN GREEN 31" - A100177



(4) EZ - CHAIN GREEN 51.25" - A100068

**STEP 54**

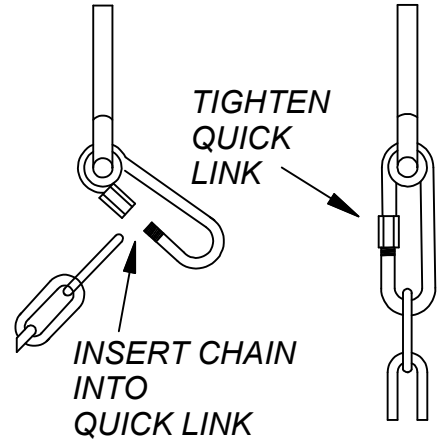
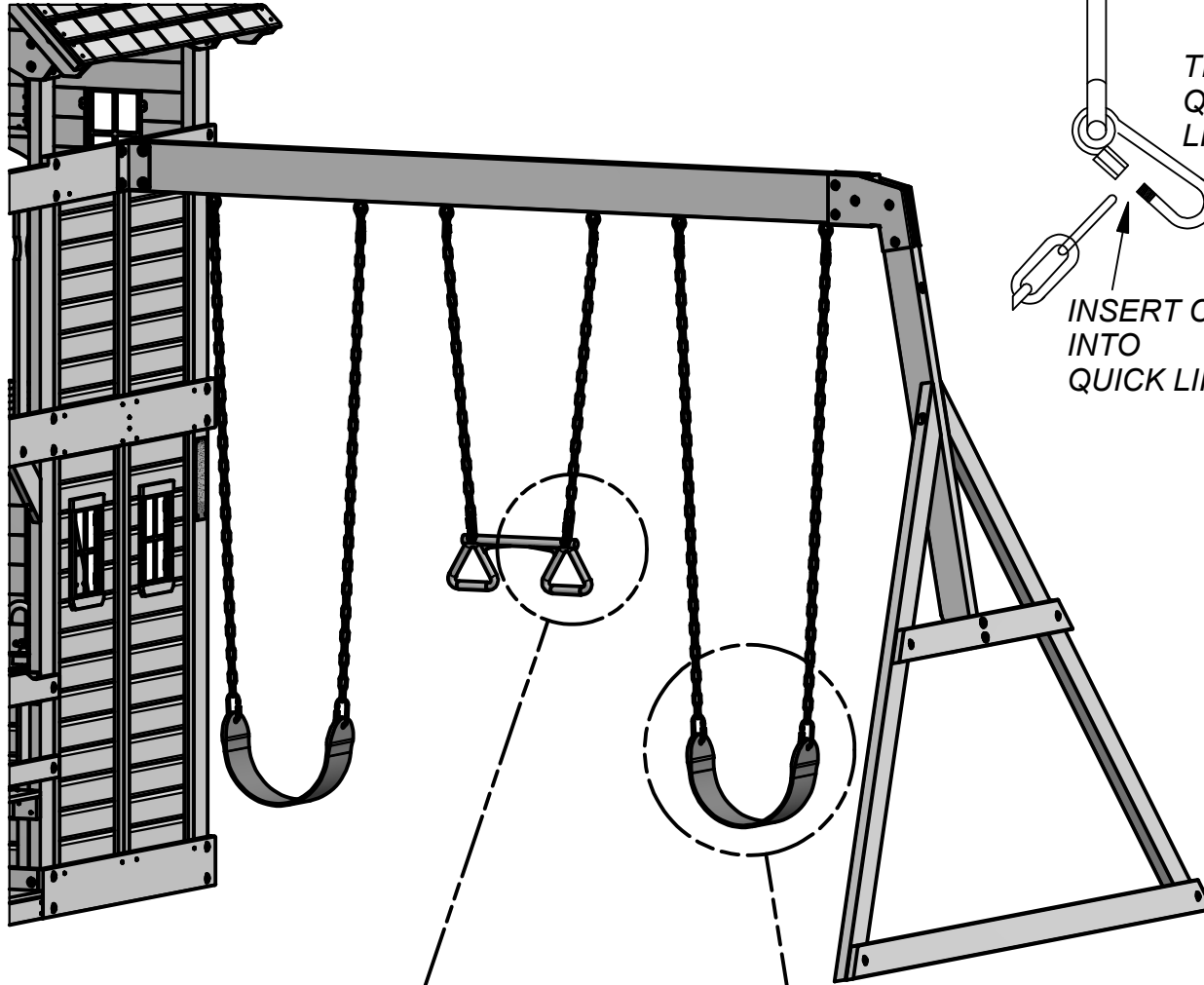

TIGHTEN QUICK LINK

INSERT CHAIN INTO QUICK LINK

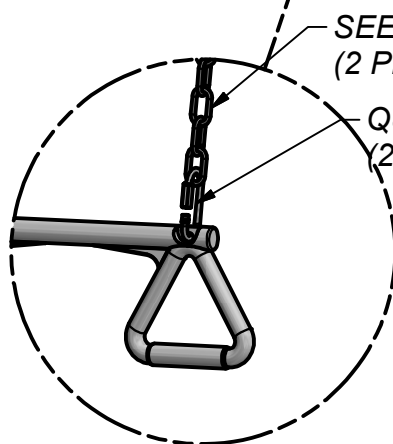

SEE TABLE (2 PLCS)

QUICK LINK (2 PLCS)

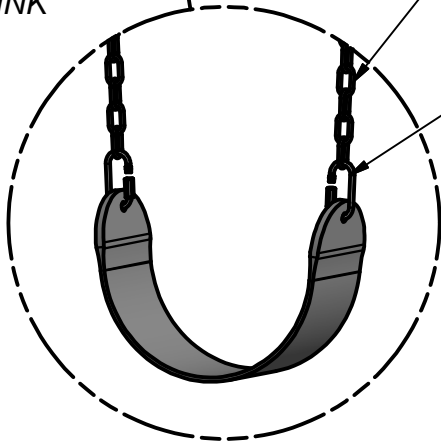

CHAIN GREEN 51.25" (4 PLCS)

QUICK LINK (4 PLCS)



(1) HC - BYD ID TAG (LARGE) WITHOUT AGES - A100242

STEP 55

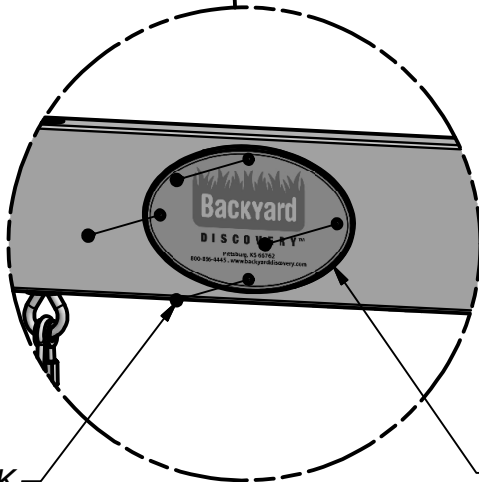
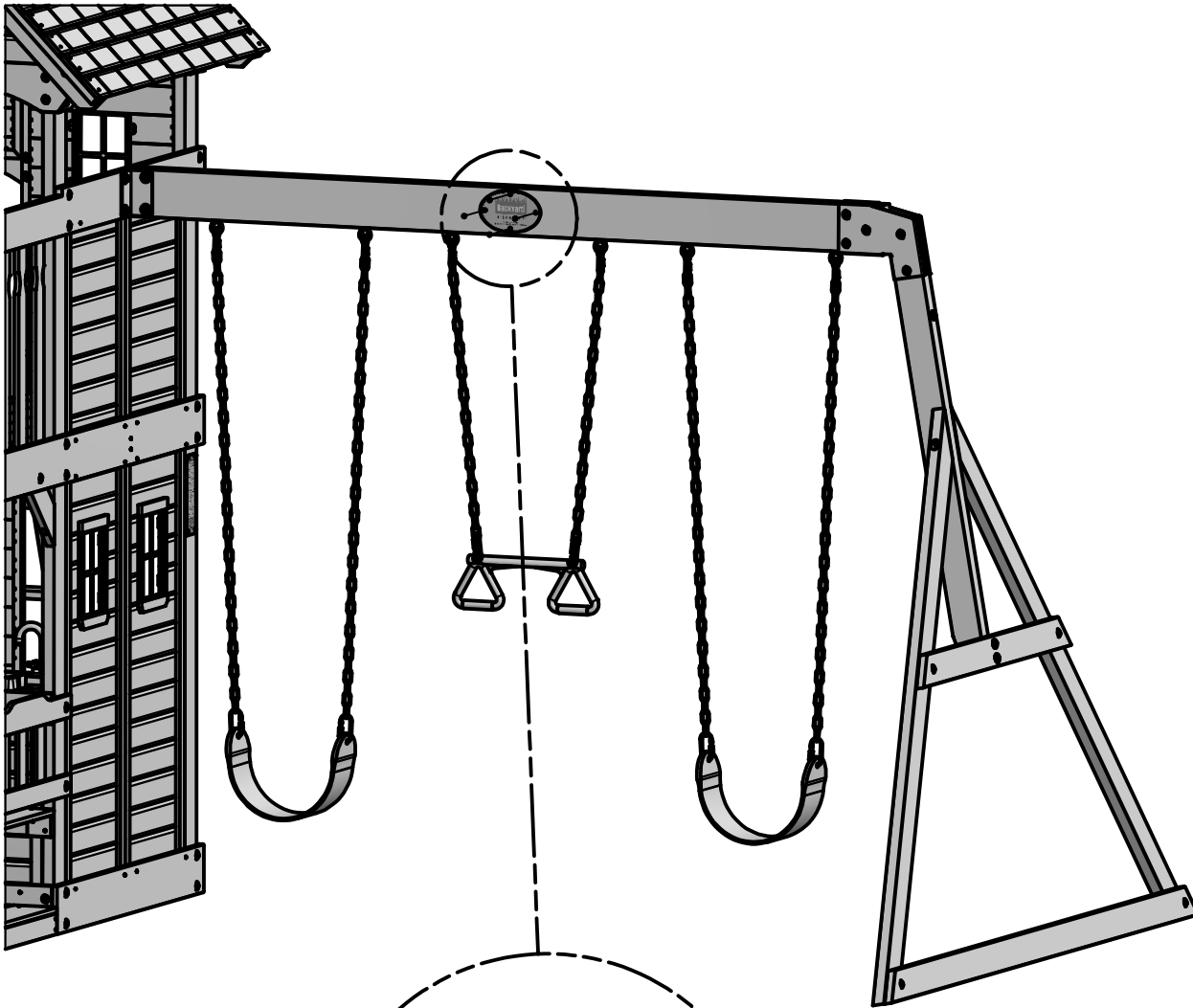

SCREW PFH 8x1/2 BLK  
(4 PLCS)

BYD ID TAG (LARGE) WITHOUT AGES

# Anchoring Instructions

**STEP 56**

TAP IN GROUND STAKES AT AN APPROXIMATE 45° ANGLE AT THE LOCATIONS SHOWN. USING GROUND STAKES AS A GUIDE, DRILL 7/16" DIA HOLES.

**NOTE:**  
FAILURE TO USE GROUND STAKES CAN VOID WARRANTY & CAUSE INJURY!

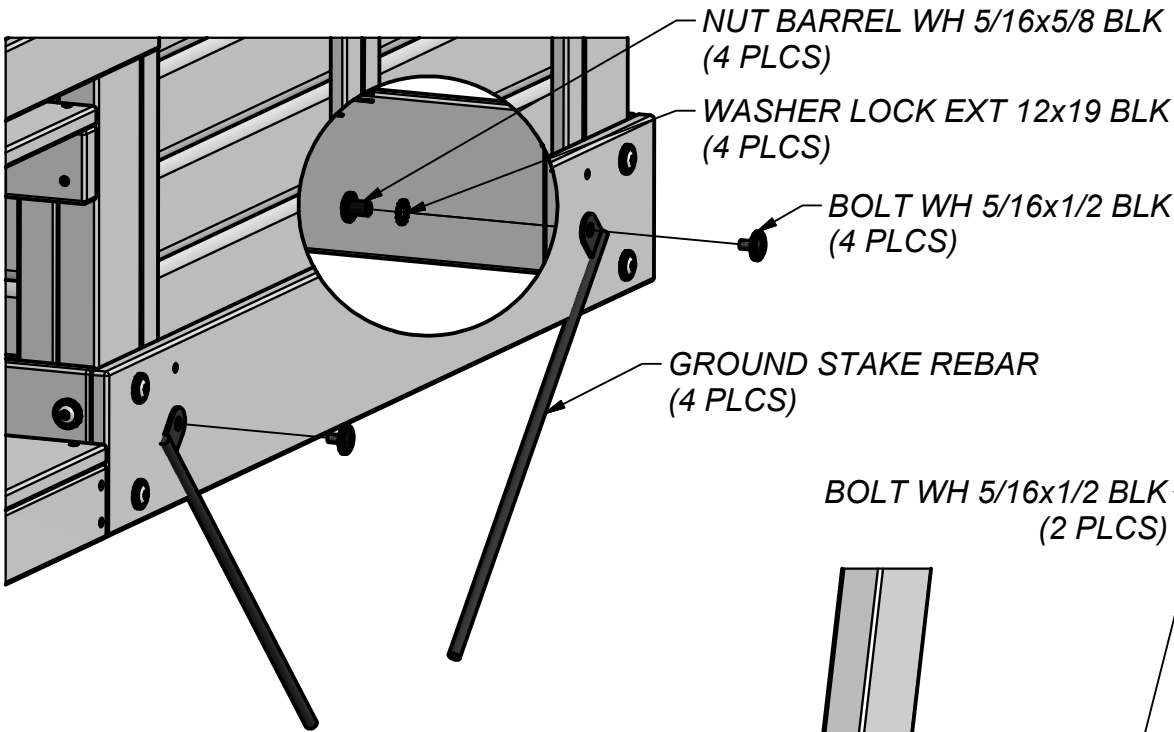

**FORT GROUND STAKES**

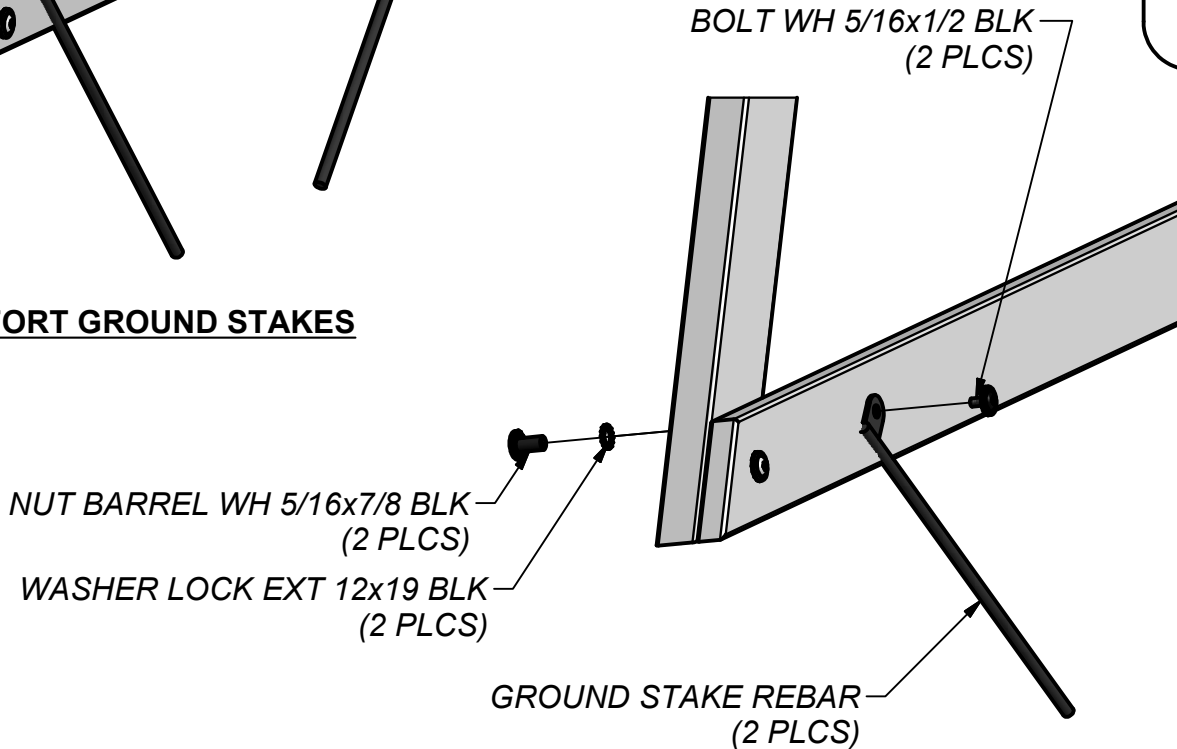

**FINAL STEP**

**SWING BEAM GROUND STAKES**

DOUBLE CHECK EVERY BOLT, SCREW AND NUT FOR TIGHTNESS. MAKE SURE EVERY BOARD IS SECURE AND MAKE SURE THE PLAY SET IS LEVEL.

ENJOY YOUR NEW PLAY SET!

