

Owner's Manual

Patio Heater

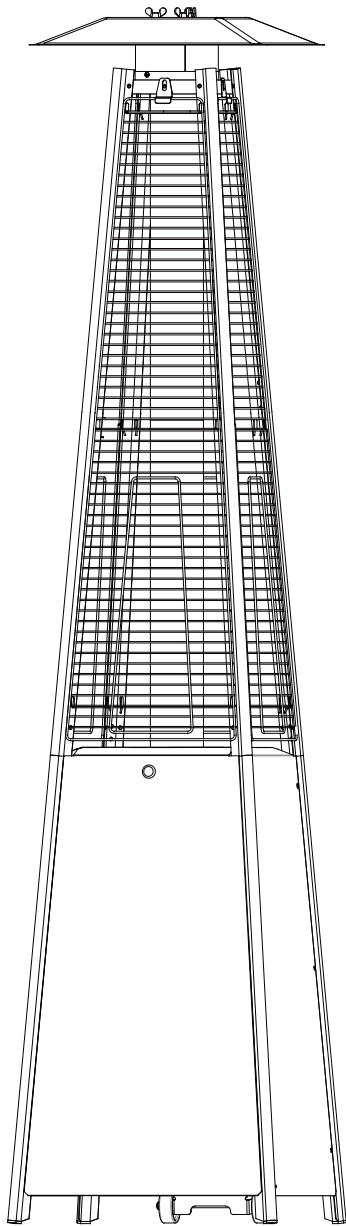

! DANGER

If you smell gas:

1. Shut off gas to the appliance.
2. Extinguish any open flame.
3. If odor continues, keep away from the appliance and immediately call your gas supplier or fire department.

! WARNING

Do not store or use gasoline or other flammable vapors and liquids in the vicinity of this or any other appliance. An LP-cylinder not connected for use shall not be stored in the vicinity of this or any other appliance.

! WARNING

For outdoor use only.

INSTALLER:

Leave this manual with the appliance.

CONSUMER:

Retain this manual for future reference.

! WARNING

Improper installation, adjustment, alteration, service or maintenance can cause injury or property damage. Read the owner's manual thoroughly before installing or servicing this equipment. If the information in this manual is not followed exactly, a fire or explosion may result causing property damage, personal injury or loss of life.



! DANGER



CARBON MONOXIDE HAZARD

This appliance can produce carbon monoxide which has no odor. Using it in an enclosed space can kill you. Never use this appliance in an enclosed space such as a camper, tent, car or home.

SAFETY INFORMATION

Before you assemble or operate this unit, please carefully read this entire manual. Failure to do so may result in a fire, explosion, injury or death.

WARNING

- The installation of this unit must adhere to local codes or Propane Storage and Handling Code, CSA B149.2.
- THIS UNIT IS INTENDED FOR OUTDOOR USE ONLY! This product shall be used outdoors, in a ventilated space and shall not be used in any enclosed area.
- This unit is to be used with propane gas only! (sold separately)
- Do not attach a remote gas supply to this unit.
- Only use propane gas for this unit.
- This unit is not intended for natural gas.
- Converting this unit to natural gas is dangerous and not recommended. The conversion of this unit will void the manufacturer warranty.
- Do not use any solid fuel or charcoal for this unit.
- If the propane gas tank is leaking gas, you may hear, see, or smell a hiss. Do the following:
 1. Disconnect the propane gas tank.
 2. Do not attempt to fix the problem yourself.
 3. Contact your gas supplier or fire department for help.
- Applying too much propane may result in gas pooling and will not burn. Allow fresh air into the unit so that the remaining gas may escape.
- Do not use a flame to check for gas leaks.
- The max. inlet supply pressure: max. Gas supply 11 in w.c. (2.74kPa)
- Use LP propane tanks with the following dimensions: diameter 12 in, height 18 in.
- You must use a propane tank that has a collar to protect the gas valve.
- DO NOT fill tank over 80 percent full.
- The tank system must be set up for vapor withdrawal.
- Discontinue use if any part of the propane tank is damaged. Rust and dents may be hazardous and should be inspected by a gas supplier.
- Do not burn anything other than the provided materials for this patio heater.
- Do not operate unit until all parts are fully assembled.
- Do not paint or color any part of this heating unit.
- Unit may be hot while in use, do not attempt to move it while in use.
- Never leave this heating unit unattended while in use.
- This unit is not intended for cooking.
- Keep any flammable items away.
- Keep a safe distance to avoid burning skin or clothing.
- Do not sit or rest hands or feet on this heating unit.
- Never place hands or fingers on upper portion of this unit while in use.
- Keep all electrical cords and fuel supply hose away from heated surfaces.
- Combustible material should not be within 48 inches of the top of the unit, or within 48 inches around the entire unit.
- Keep the appliance area clear and free from combustible material, gasoline and other flammable vapors and liquids.
- If the flame goes out while burning, turn the gas valve off. Wait 5 minutes before repeating the initial lighting procedure. Once you have a flame started, hold down the control knob for 1 minute.
- Do not add water into the unit.
- Do not operate unit if any part has been under water. Call a service technician to replace any

damaged parts should this occur.

- Do not disconnect any part while unit is in use.
- Do not store a spare propane tank on or near this unit.
- If the heating unit is indoors, detach the propane tank and leave outdoors.
- Do not operate on a boat or vehicle. This unit must be used on a flat surface and outdoors ONLY.
- Always remove protective cover before operating (if applicable).
- Check for leaks after not using the unit for long periods of time.
- Children should never operate this unit. Children must be supervised while near this unit.
- Keep gas tank at least 5 feet away from unit when lit. (if external tank)
- The maximum gas supply pressure is 250psi.
- **All installation and repair should be done by a qualified professional. This unit should be inspected annually and cleaned regularly.**
- Inspect all elements of this heating unit before each use. If there is damage, the burner must be replaced.
- Be aware of the hazards of high temperatures and stay away from the unit to avoid any burns or injury.
- The gas supply tank should be constructed and marked with the specifications for the LP gas tanks of the U.S. Department of Transportation or the National Standard of Canada CAN/CSA-B339, LP gas tanks, spheres and tubes for Transportation of Dangerous Goods; and Commission.
- The LP gas tank must have a listed overfilling prevention device and a QCCI or Type I, (CGA791) LP gas tank connection.
- This heating appliance should not be used on plastic or artificial wood decks.
- Children and adults should be alerted to the hazards of high surface temperatures and should stay away to avoid burns or clothing ignition.
- Young children should be carefully supervised when they are in the area of the appliance.
- **Clothing or other flammable materials should not be hung from the appliance or placed on or near the appliance.**
- Any guard or other protective device removed for servicing the appliance shall be replaced prior to operating the appliance.
- **Installation and repair should be done by a qualified service person. The appliance should be inspected before use and at least annually by a qualified service person. More frequent cleaning may be required as necessary. It is imperative that the control compartment, burners and circulating airways of the appliance are kept clean.**

Only use the regulator and hose assembly provided with this unit.

Inspect the burner before use of this unit. If the burner shows any kind of damage, do not operate the appliance.

NOTE: You must follow all steps to properly assemble this heating item. Make sure the gas valve is turned "OFF" before assembling. Do NOT attempt to assemble without proper tools.

SAFETY INFORMATION

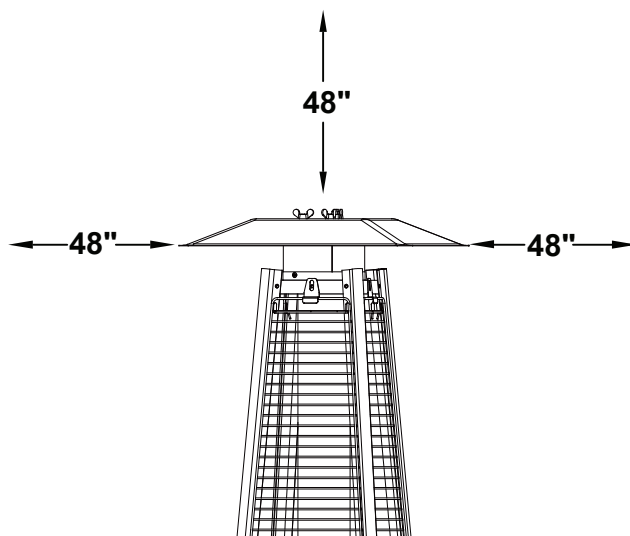

BE CAREFUL: WHEN CERTAIN MATERIALS OR ITEMS ARE STORED ABOVE, BESIDE OR UNDER THIS HEATER WHILE IN USE, THEY WILL BE SUBJECT TO RADIANT HEAT AND COULD BE SERIOUSLY DAMAGED.

Combustible materials should not be within inches of the top of the unit, or within **48** inches around the entire unit.

HARDWARE

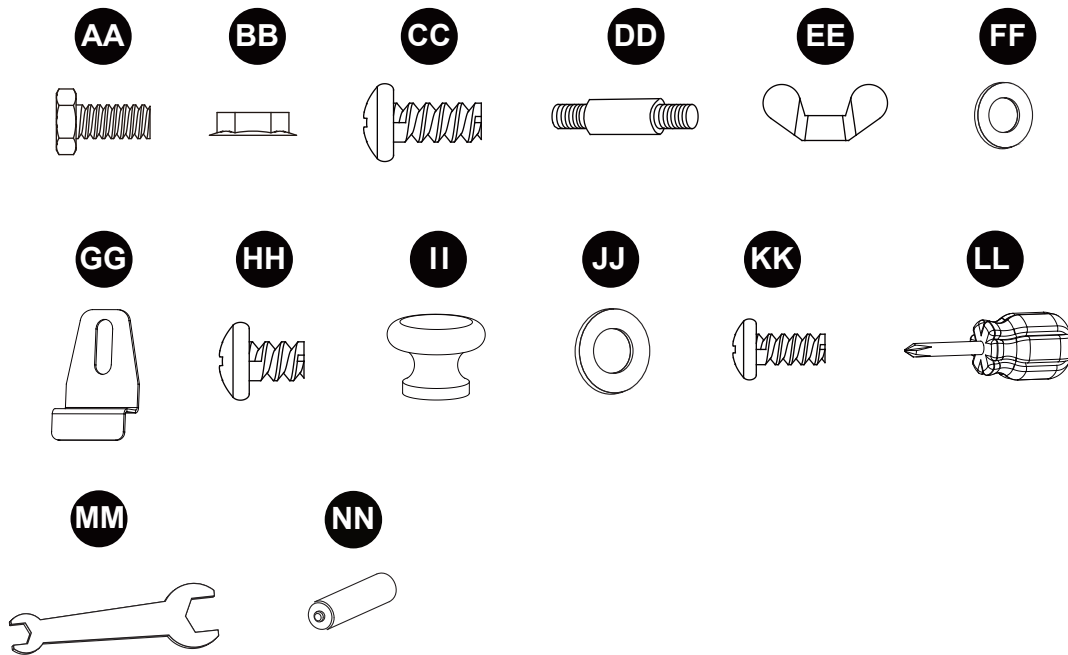

Item	Description	Qty
AA	Bolt M6x10	4
BB	M6 nut	4
CC	Screw M5x10	16
DD	Stud	3
EE	Wing nut	3
FF	Flat washer	6
GG	Fixing Bracket	4
HH	Screw 3/16"	30
II	Knob	1
JJ	Large flat washer	1
KK	Screw M4 X 8	1
LL	Philips screwdriver	1
MM	Wrench	1
NN	AA Battery (1.5 V)	1

Before beginning assembly of product, make sure all parts are present. Compare parts with package contents list and hardware contents list. If any parts are missing or damaged, do not attempt to assemble the product.

Estimated Assembly Time: 90 minutes

CONTENTS

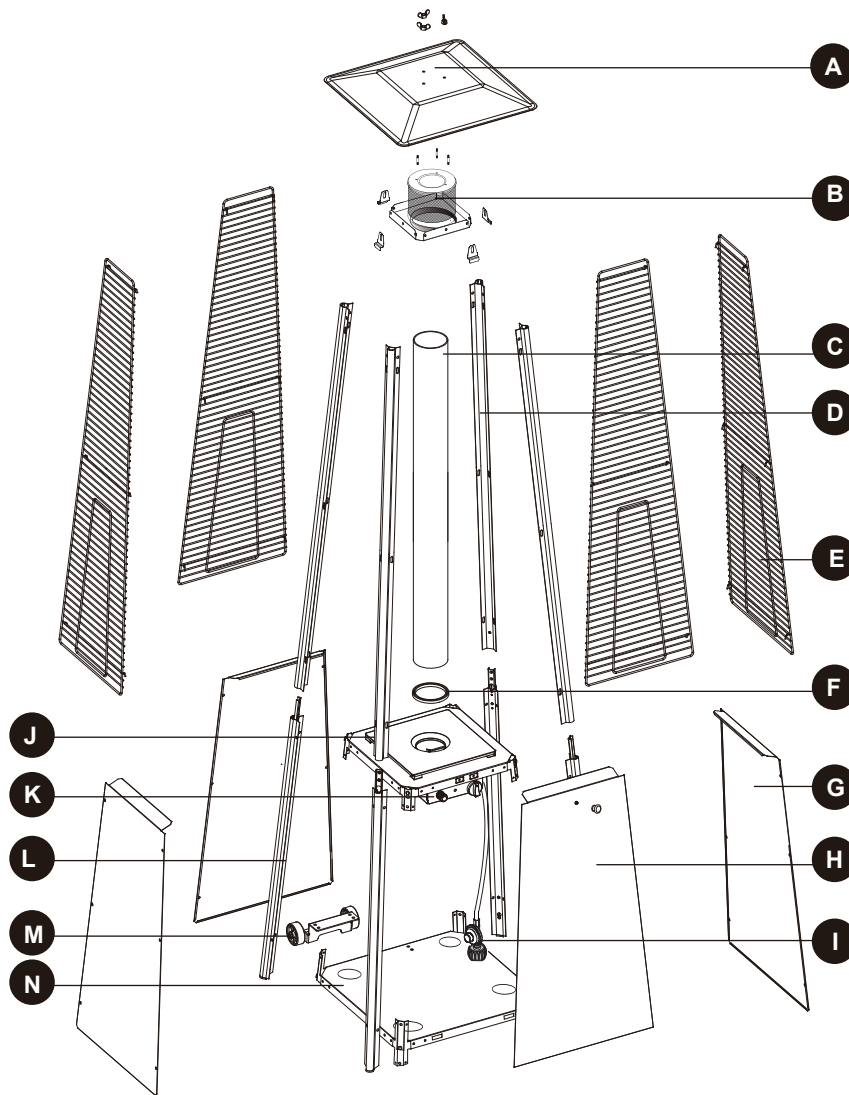



Item	Description	Qty
A	Reflector	1
B	Top Plate Assy	1
C	Glass Tube	1
D	Upper Support	4
E	Protective Guard	4
F	Black Silicone Ring	1
G	Side Panel	3
H	Front Panel	1
I	Gas Hose & Regulator	1
J	Middle Plate	1
K	Control Box Assy	1
L	Lower Support	4
M	Wheel Assembly	1
N	Bottom Plate	1

ASSEMBLY INSTRUCTIONS

1. Assemble the wheel assembly (M) to the bottom plate (N) using 4pcs bolt M6x10 (AA) and 4pcs M6 nut (BB).

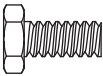
Hardware Used

AA	Bolt M6x10		x 4
BB	M6 nut		x 4

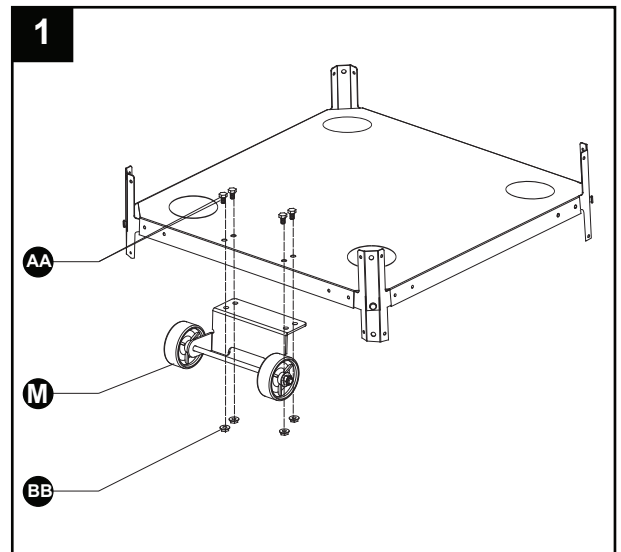

2-1. Unscrew the ignition, load small battery, tighten the ignition.

2-2. Insert the pins of the bottom plate (N) to the holes of lower support (L), press to secure the pins. using 4pcs screw M5x10 to secure the bottom plate and lower support.

Insert the pins of the control box assy (K) to the holes of lower support (L), press to secure the pins. using 4pcs screw M5x10 to secure the lower support and control box assy.

Hardware Used

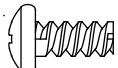
CC	screw M5x10		x 8
-----------	-------------	---	-----

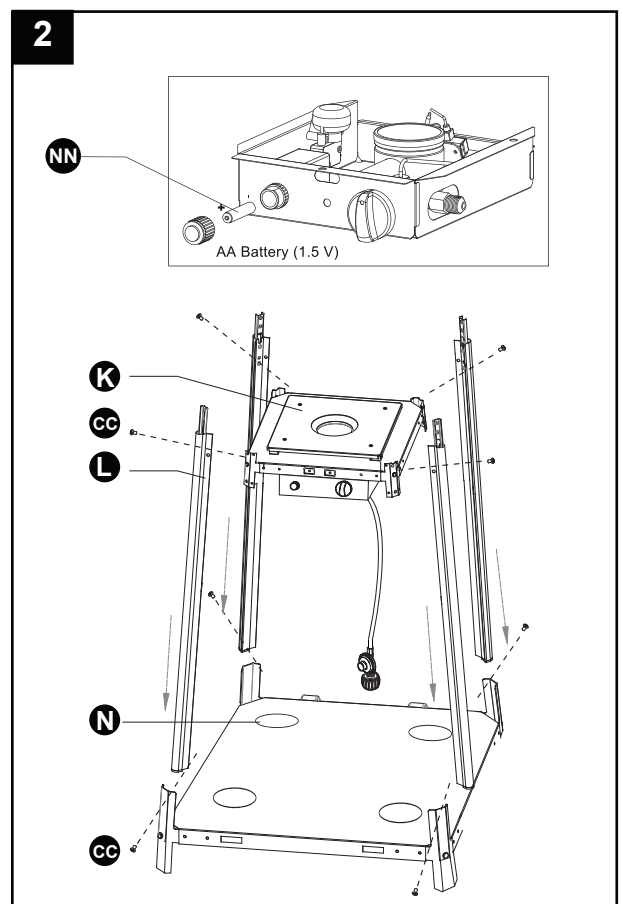

ATTENTION:

Ensure control box and front panel are on opposite side to wheels.



3. Insert upper support (D) to lower support (L) using 8pcs screw M5x10.
Assemble top plate assy (B) to upper support (D) using 8pcs screw 3/16”.

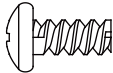

Hardware Used

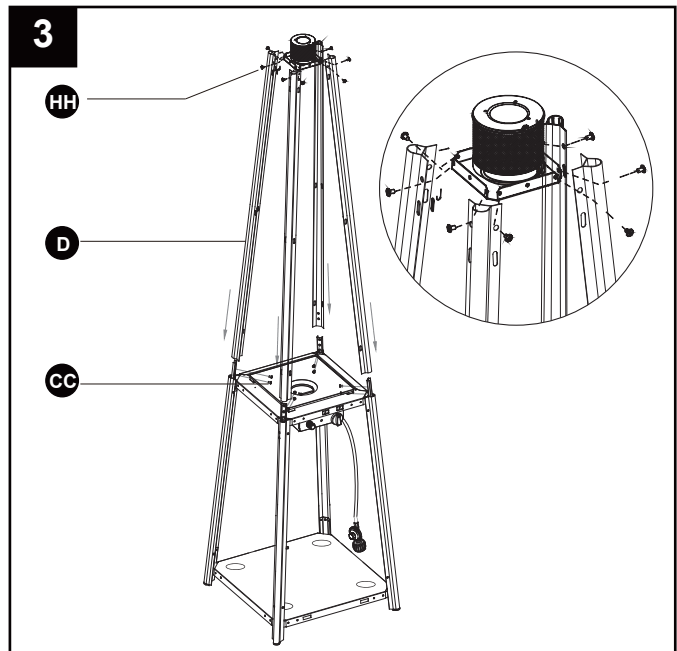
- CC** screw M5x10  x 8
- HH** Screw 3/16”  x 8

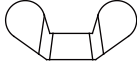
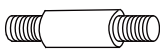

4. Assemble the reflector (A) onto the top plate assy (B).
Screw the 3pcs stud (DD) on the top plate assy (B), put 3pcs flat washer (FF) onto the top of stud (DD), then put the reflector on the the stud (DD), secure them with 3pcs flat washer (FF) and 3pcs wing nut (EE).

Hardware Used

- EE** Wing nut  x 3
- DD** Stud  x 3
- FF** Flat washer  x 6

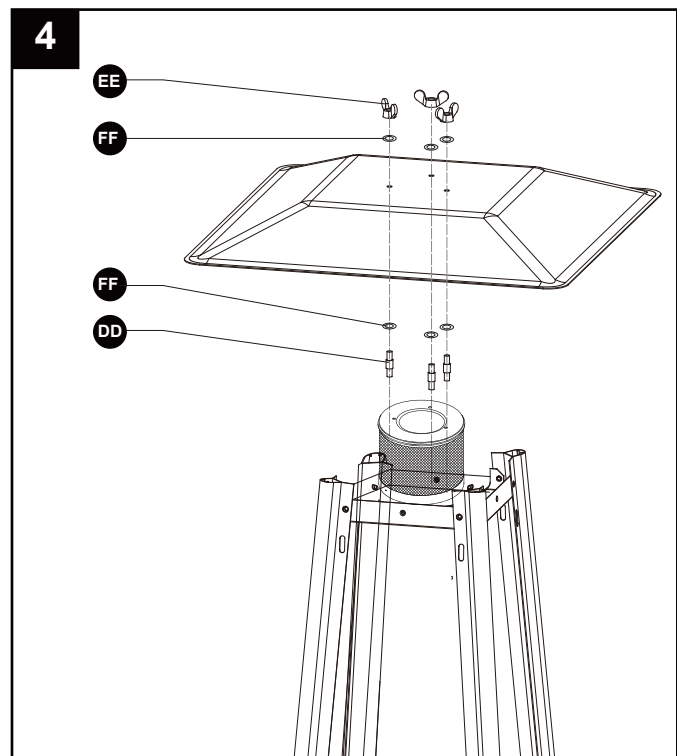

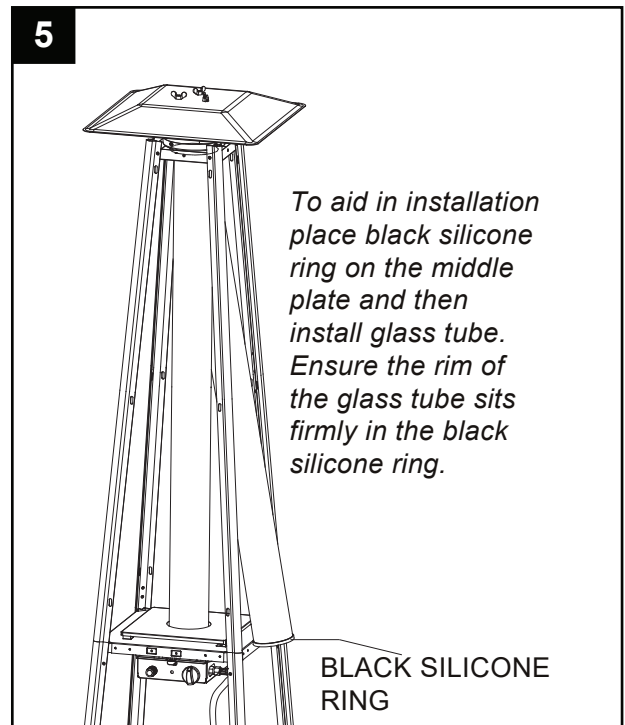

5. Carefully install the glass tube (C) by lifting up and inserting through the center hole in the top plate assy (B). Ensure the black silicone ring (F) is attached to the lower edge of the glass tube (C) as illustrated. Slide the glass tube (C) through the hole of the lower plate cover and onto the middle plate (J). Check and ensure that the glass tube (C) is positioned properly and is completely covering the center hole of the middle plate(J).

WARNING! The black silicone ring must be in place prior to operating the heater.



6. Assembly the protective guard (E). Hang the hooks of the protective guard (E) onto the holes in supports. Secure the protective guards (E) with fixing brackets (GG) with 4pcs screw Screw 3/16" (HH).

Hardware Used

- | | | | |
|-----------|----------------|---|-----|
| HH | Screw 3/16" |  | x 4 |
| GG | Fixing Bracket |  | x 4 |

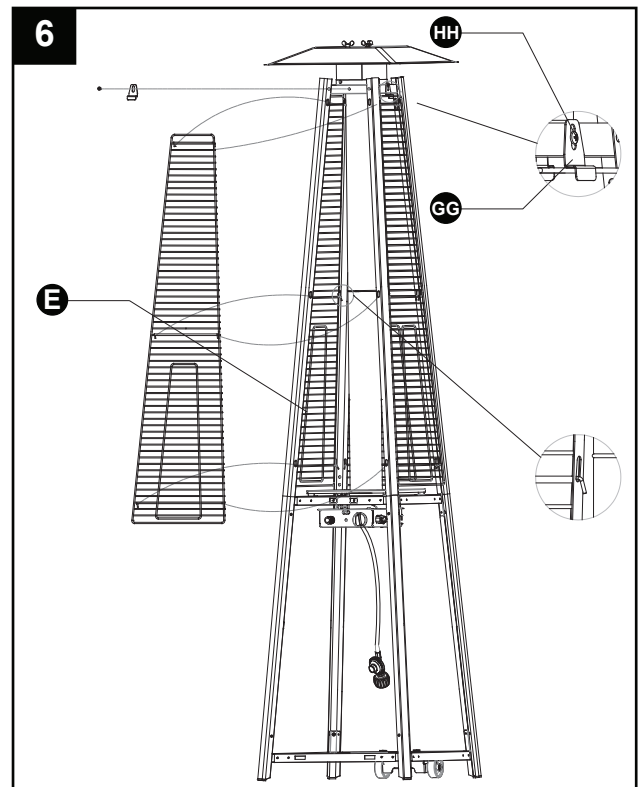

7. Assemble three side panels (G) to heater using 18pcs screw 3/16".

Attention:

Do not cover the front side where the control knob is.

Hardware Used

HH Screw 3/16"  x 18

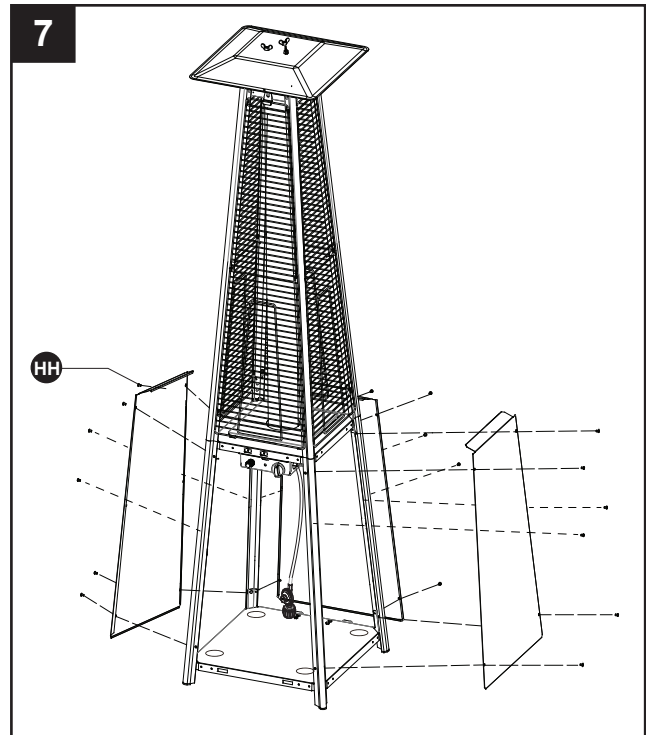

8. Install the knob (II) to screw M4x8 (KK) and large flat washer (JJ). Put the pothook of front panel (H) to the holes of bottom plate (N).

Hardware Used

II Knob  x 1

KK Screw M4 X 8  x 1

JJ Large flat washer  x 1

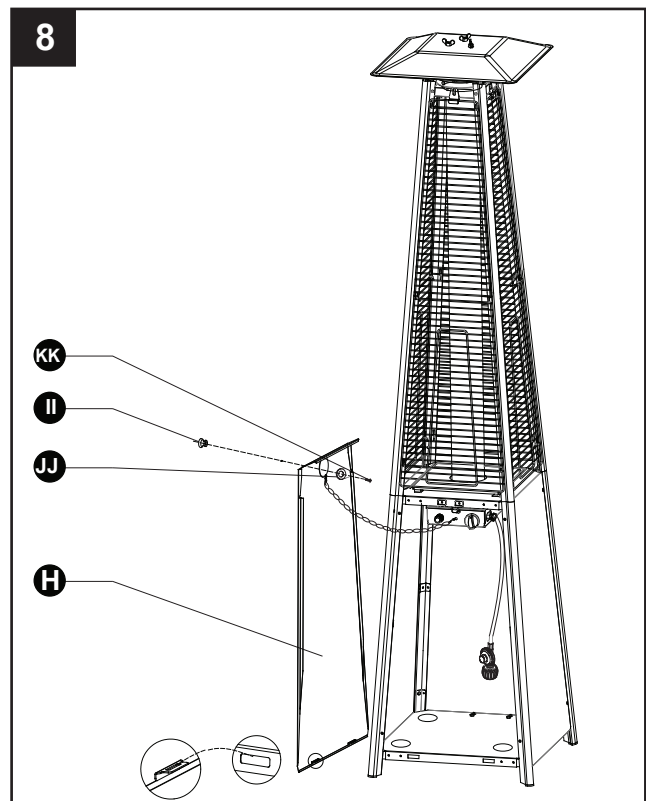

9. Place the propane gas tank (not included) on the base.

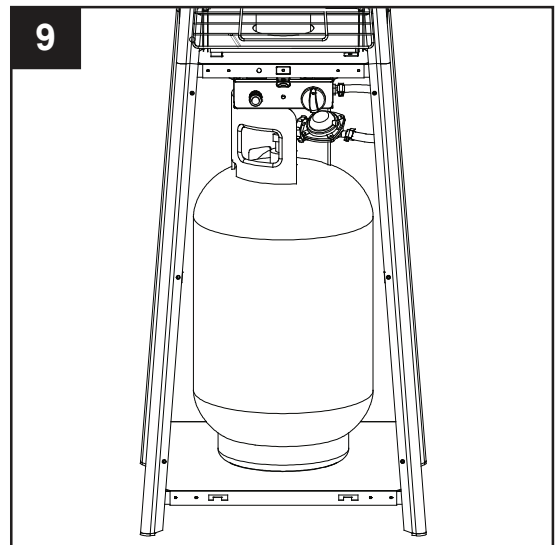

10. Turn the cylinder valve on the tank clockwise to close the propane tank. Attach the regulator (J) to the cylinder valve by turning the regulator coupling nut clockwise. Make sure it is fastened securely and tighten connections by hand only.

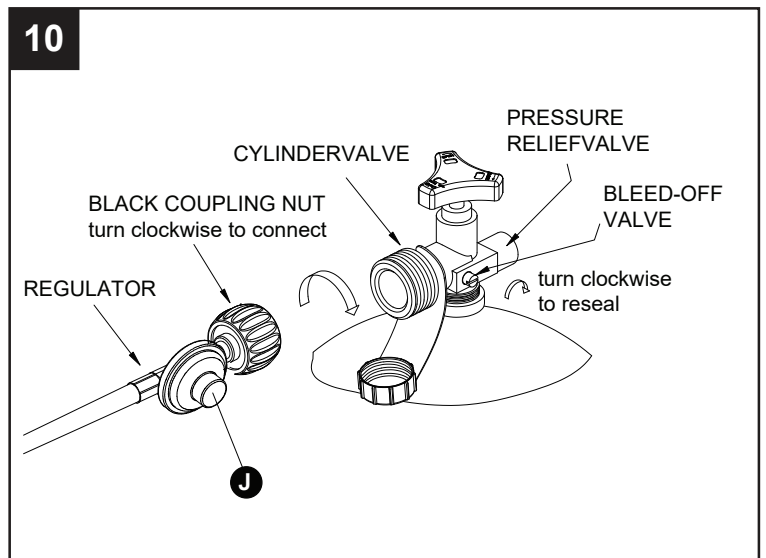

OPERATION

Before performing a leak test, be sure that no sparks can occur and you are in a spacious outdoor area. Connect the propane gas tank to the regulator and turn the valve on the unit to the "off" position. Brush a soap and water mixture on all connections. Turn the gas supply on; if bubbles occur on any connection there may be a leak. If you smell gas or a leak is discovered turn the gas valve off, disconnect propane gas tank and do not use the appliance until the leak is repaired.

Do not use the heating unit without inspecting the gas hose. If there are signs of wear or abrasion you must replace the hose (if applicable).

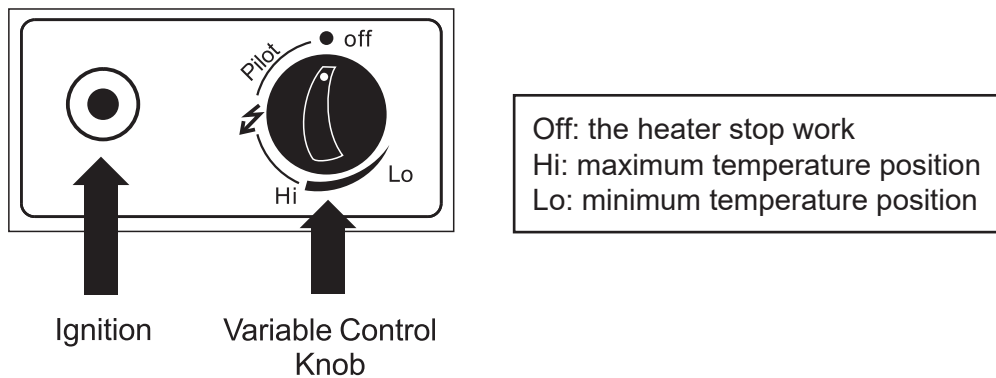

TO TURN THE HEATER ON

WARNING: Please ensure the glass tube has not been damaged before operation

1. Ensure the variable control knob is at the OFF position
2. Connect the gas regulator to a compatible gas cylinder
3. Push and turn the variable control knob to the "Pilot " position and hold for 60 seconds. Whilst still holding the control knob down, press the ignition button. A pilot flame should appear.
4. Once the blue pilot flame stays alight constantly, let go of the variable knob.
5. Turn the variable control knob to the desired temperature position – Lo to Hi

IMPORTANT NOTE

- When lighting the heater for the first time or a new cylinder is connected, the air inside the hose must be purged. This process will take a few minutes as liquefied petroleum gas is heavier than air
- As a result the variable control knob should be pressed down at the Pilot position for 3 Minutes instead of the normal 60 second period
- This ensures the gas purges the air in the hose and passes from the cylinder through to the main burner

TO TURN THE HEATER OFF

1. Turn the variable control to the PILOT position
2. Push and turn the variable control knob to the OFF position
3. Turn the regulator connected to the gas cylinder to the OFF position

MAINTENANCE

- Before performing any maintenance always disconnect propane gas tank.
- Keep the heating item free and clear from combustible materials.
- Visually inspect burner for obstructions and keep tank enclosure free and clear from debris.
- Use a soft brush to get rid of the mild stains, loose dirt and soil after the burner is completely cooled down. Wipe down with a soft cloth.
- Harsh weather conditions may cause stubborn stains, discoloration and possibly rust pitting.
- Permanent damage may occur if powder or solvent comes in contact with painted or plastic components on this heating unit.
- Keep the heating unit stored away from direct sunlight.
- If storing this unit inside, disconnect the propane gas tank from the gas valve.
- Not using manufacturer approved or supplied parts/accessories may result in a defective condition and void the warranty of this heating unit.
- Always place lid (if applicable) or protective cover on heating item when not in use.

TROUBLESHOOTING

Problem	Cause	Solution
The burner will not light.	The burner injector is clogged.	Clean the burner injector.
	There is low gas supply pressure.	Call your gas supplier.
The burner flame goes off immediately after ignition.	There is low gas pressure.	Call your gas supplier.
The ignition is delayed.	The main burner carryover ports are clogged.	Clean the main burner ports.
	There is low gas pressure.	Call your gas supplier.
The combustion on the burner is inadequate.	There is not enough air.	Check the air passageways and burners for dirt and debris, and clean with compressed air.
The burner flame is low.	The supply hose is bent or twisted.	Straighten the hose and perform a leak test.
	There is blockage in the burner injector.	Clean or replace the burner injector.
The emitter glows uneven.	There is blockage in the burner injector.	Clean or replace the burner injector.
	The base is not on a level surface.	Place the heater on a level surface.
	The gas pressure is low.	Replace the cylinder with a new cylinder.
There is slight smoke and odor during initial operation.	This is residue from the manufacturing process.	This will stop after approximately 30 minutes of operation.
There is thick black smoke.	There is blockage in the burner.	Turn off the heater and let it cool. Remove the blockage and clean the inside and outside of the burner.
The heater produces a whistling noise when the burner is lit.	Air passageways are blocked.	Check the minimum installation clearances and air passageways for debris.
	There is air in the gas line.	Operate the burner until the air is completely purged.
The heater produces a clicking noise just after the burner is lit or turned off.	The metal is expanding and contracting.	This is common with heaters. If noise is excessive, contact a qualified service person.
There is a gas odor even when the control knob is in the OFF position.	There is a gas leak.	Locate and correct the leak immediately.
	The gas control is defective.	Replace the gas control.
There is a gas odor during combustion.	There is foreign matter in the gas or on the burner ports.	Check the gas passageway and burner.
	The heater is burning vapors from paint or impurities in the air.	Stop storing and using odor causing products near the heater.
	There is gas leaking from the regulator and hose connection, the valve and pipe connections, and the pipes.	Locate and correct the leaks, or contact your gas supplier.
There is carbon build-up.	There is dirt or film on the reflector and flame screen.	Clean the reflector and flame screen.