



14x10 FT Storage Shed





Installation Instructions

Our team is available 24/7 to help with any product questions. Contact us anytime!

- i Recommended to wear gloves to avoid scratches. Please read the instructions COMPLETELY before assembly.

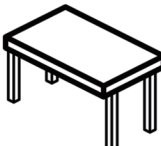
After opening the package, if you notice a slight deformation in the wall panels, there's no need for concern. Our material is flexible and can be manually bent back into place.

REQUIRED TOOLS

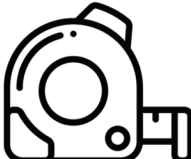
Tools			
	Gloves	Table	Ladder
			
	Power drill	Screw driver	Tape Measure

ASSEMBLY TIPS

1. Clear a working area to allow access on all four sides. A raised work surface will make assembly easier. It is easier to install the wall panel on the table.
2. All parts are identified, so when working through the instructions page by page, the diagrams show where each part is positioned.
3. Before starting, to avoid any accidental injury, we recommend the use of gloves to protect your hands.
4. Please keep children away from your construction site.
5. Most assembly can be completed by one person, but assistance may be needed when you reach the erection stage.
6. Please note: Some local government authorities have rules & regulations on shed installation, and you may need approval to erect this shed.





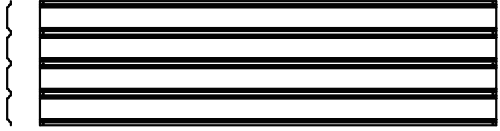
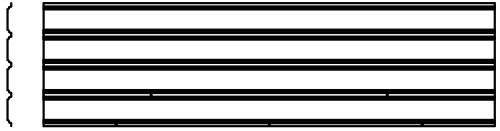
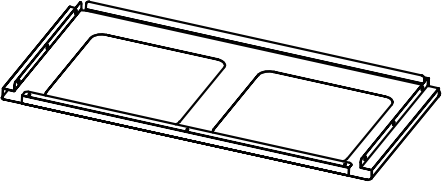

ASSEMBLY STEPS

1. Unpack all components from the carton and lay them out beside your work area. Check parts against the parts list.
2. Work through the assembly instructions page by page.
3. Once assembly is completed, place the shed in position and fix the anchor to the ground.
4. Clean up all metal pieces and screws.

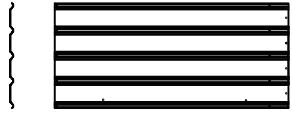





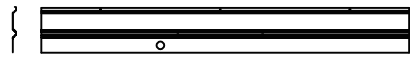
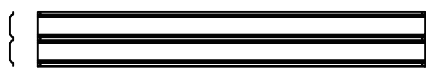
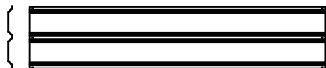





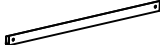



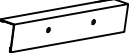

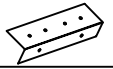









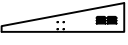

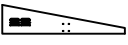













F1410parts list(A)

PART	NO.	QTY.
	W5-D	24
	W5-KD	2
	TCH	2

F1410parts list(B)

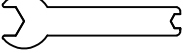
PART	NO.	QTY.
	F1209-7L	2
	F1209-7M	16
	F1209-7R	2
	W5-G	1
	W5-CD	4
	W2-HLD	1
	W2-HRD	1
	W3-D	1
	W3-G	1

F1410parts list(C)

PART	NO.	QTY.	PART	NO.	QTY.
	K810-1	2		DRAD	1
	K810-1R	2		DDA	4
	K1014-2L	2		DBD	4
	F1410-2R	2		C3	4
	K1014-2M	2		K1012-11	8
	K810-3L	2		TCH3	1
	K810-3	2		TCH5	1
	K1014-4L	2		TCH6	1
	K1014-4M	2		TCH7	1
	F1410-4R	2		GC	4
	F1410-5L	2		GE	2
	F1410-5R	2		T-F	4
	K1014-6L	6		DC	2
	K1014-6M	6		C2	4
	K1014-6R	6		DJ	4
	F1209-8	4		ST4.2*10(F1)	645
	F1410-9L	2		M4*10(F2)	110
	F1410-9M	2		∅10*∅4*1(V2)	222
	F1410-9R	2		ST4*16(F4)	4
	K1014-10	2		GL	1
	K1014-10M	1		SL	124
	UAG	2		M20	1
	DAG	2		ST	2
	DLAD	1			

STEP 1

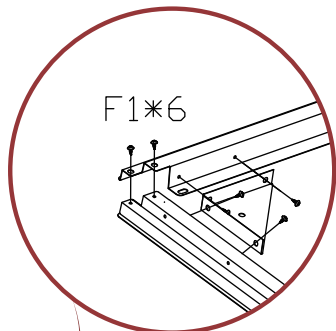

X4

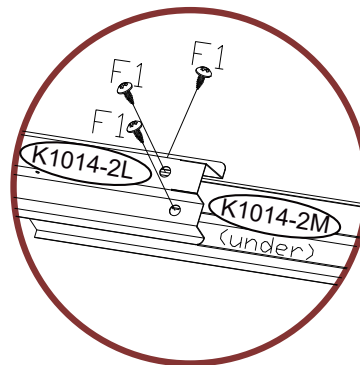
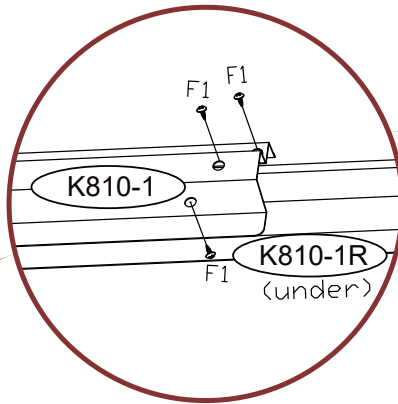
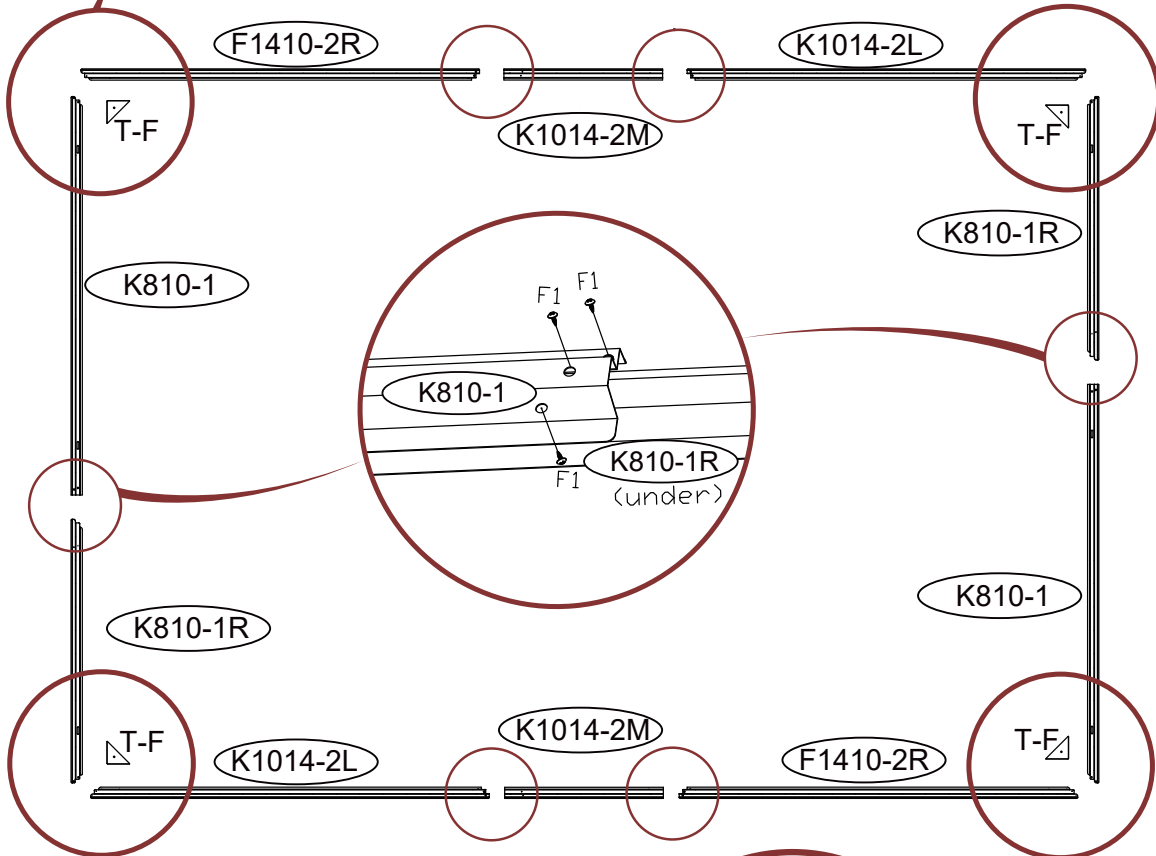
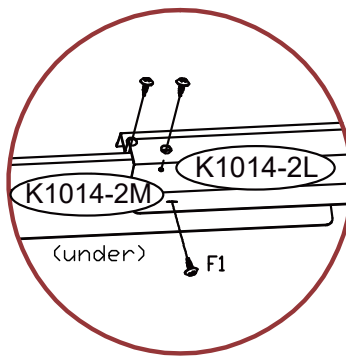

F1410-2R K1014-2M K1014-2L

K810-1

K810-1R

The base is a docking structure, and the diagonal dimensions need to be consistent during assembly, with a flat ground, otherwise it will affect the entire tool room structure.

K810-1R

K810-1

K1014-2L K1014-2M F1410-2R

	F1	42
---	----	----

STEP 2

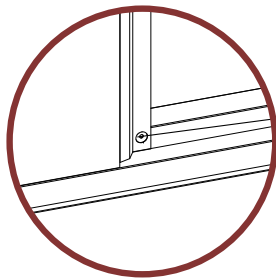
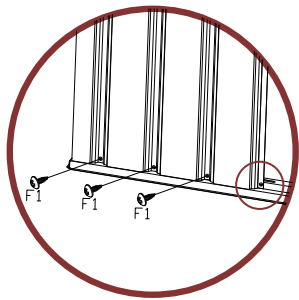
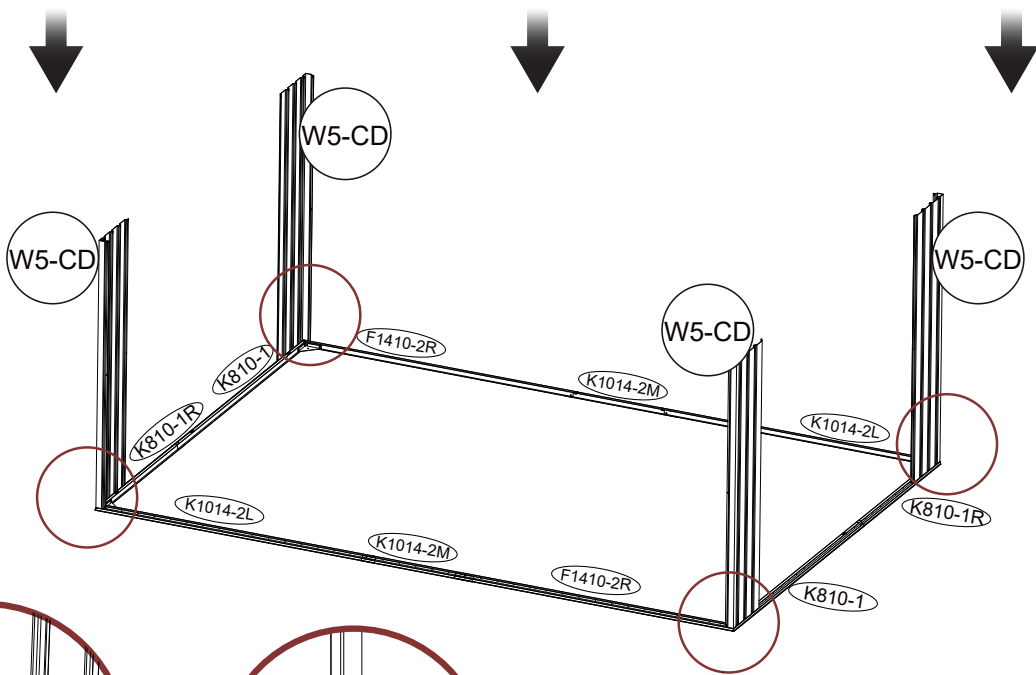
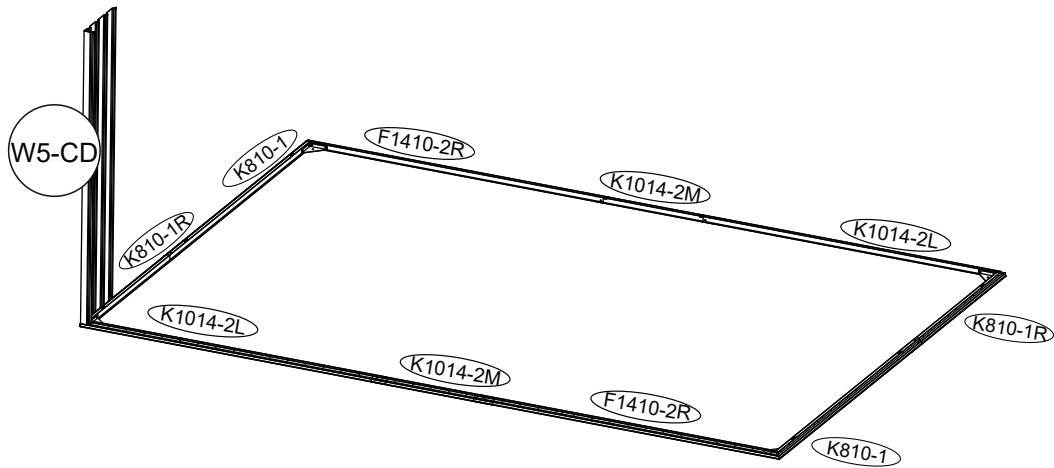

Do not add screws that indicated with an X in diagram. These need to be left undone.

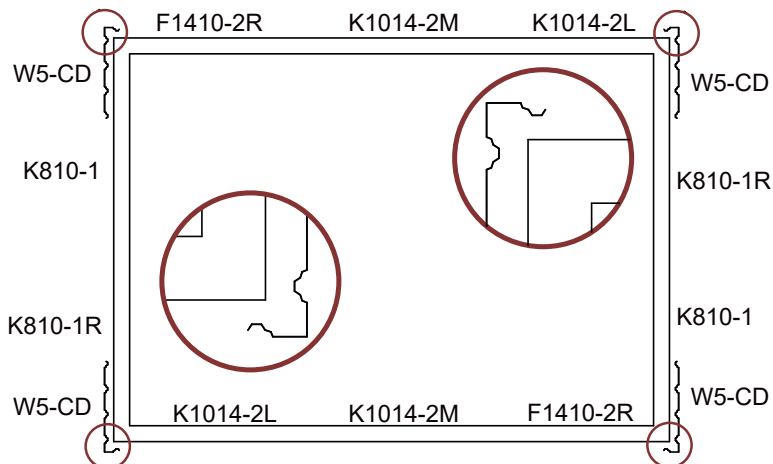

	F1	12
---	----	----

STEP 3

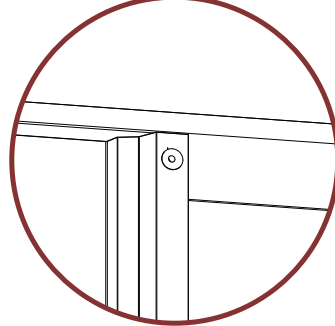
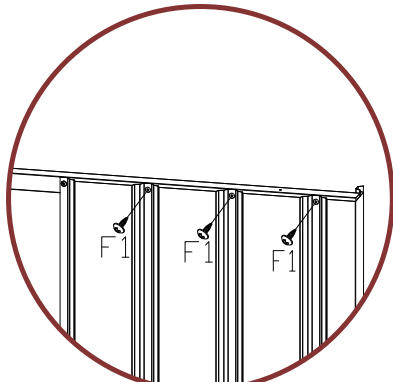
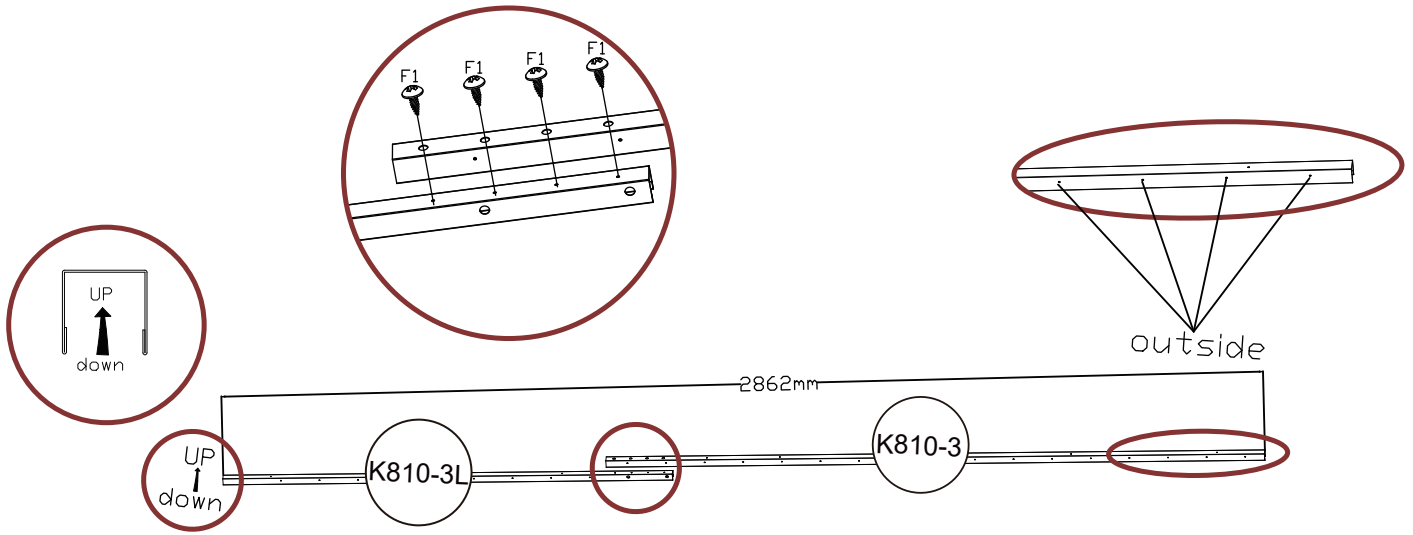

Do not add screws that indicated with an X in diagram. These need to be left undone.

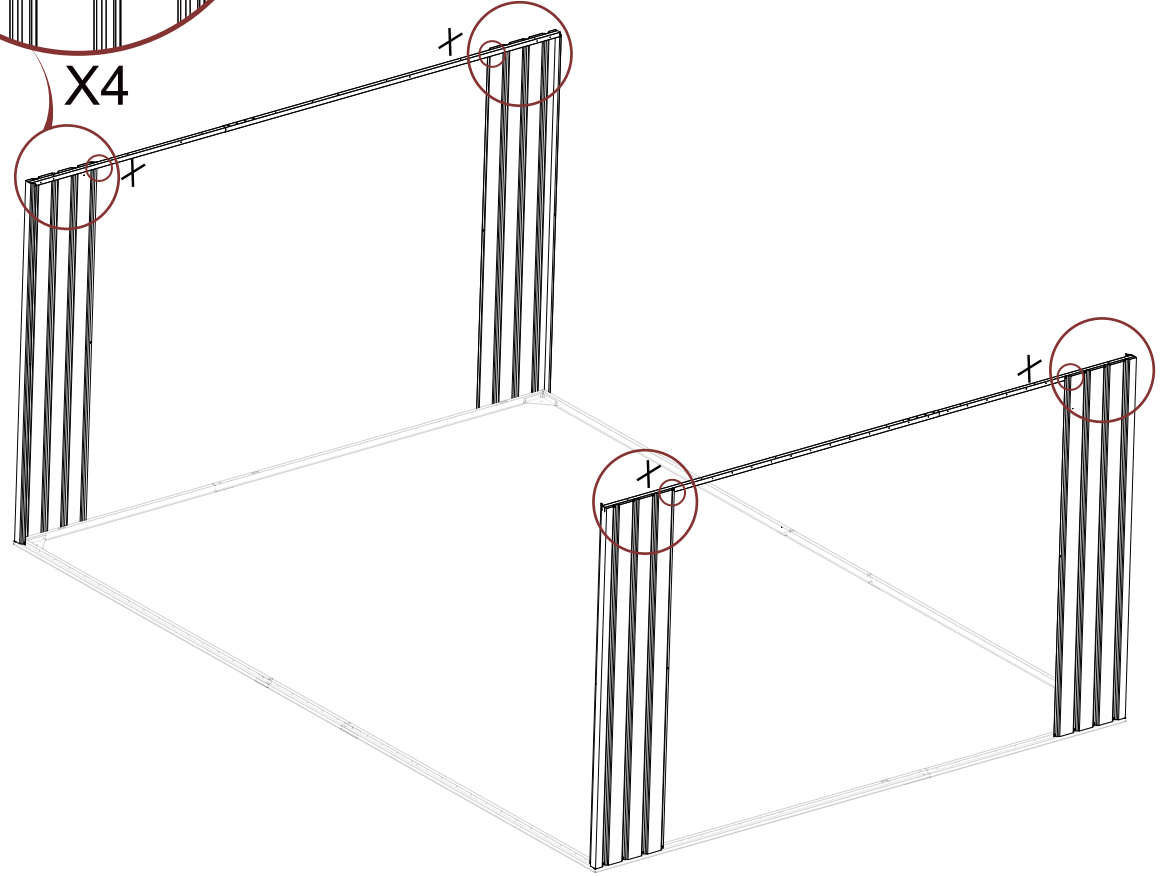



X4

	F1	20
---	----	----

STEP 4

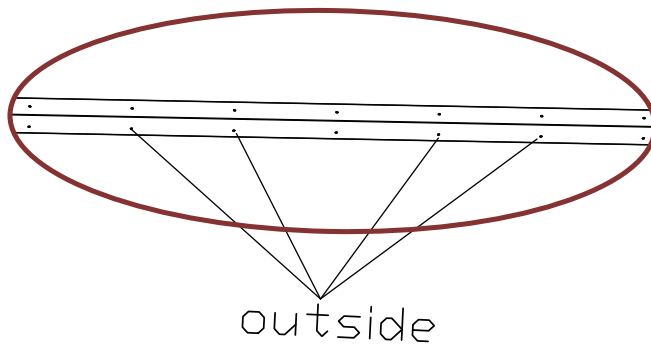
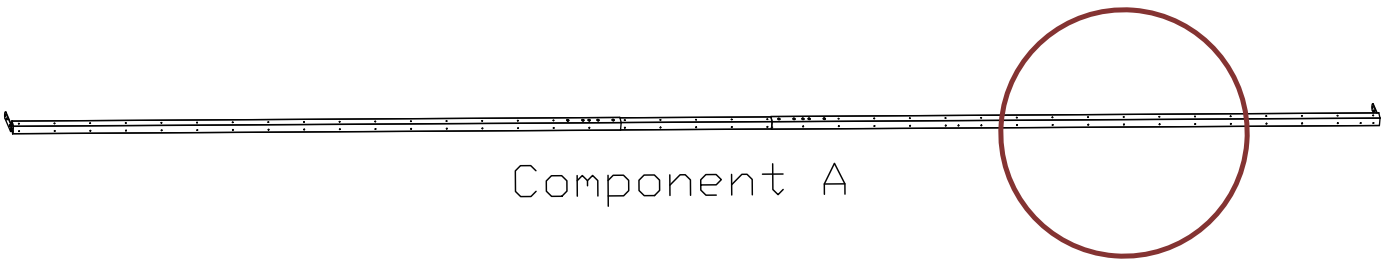
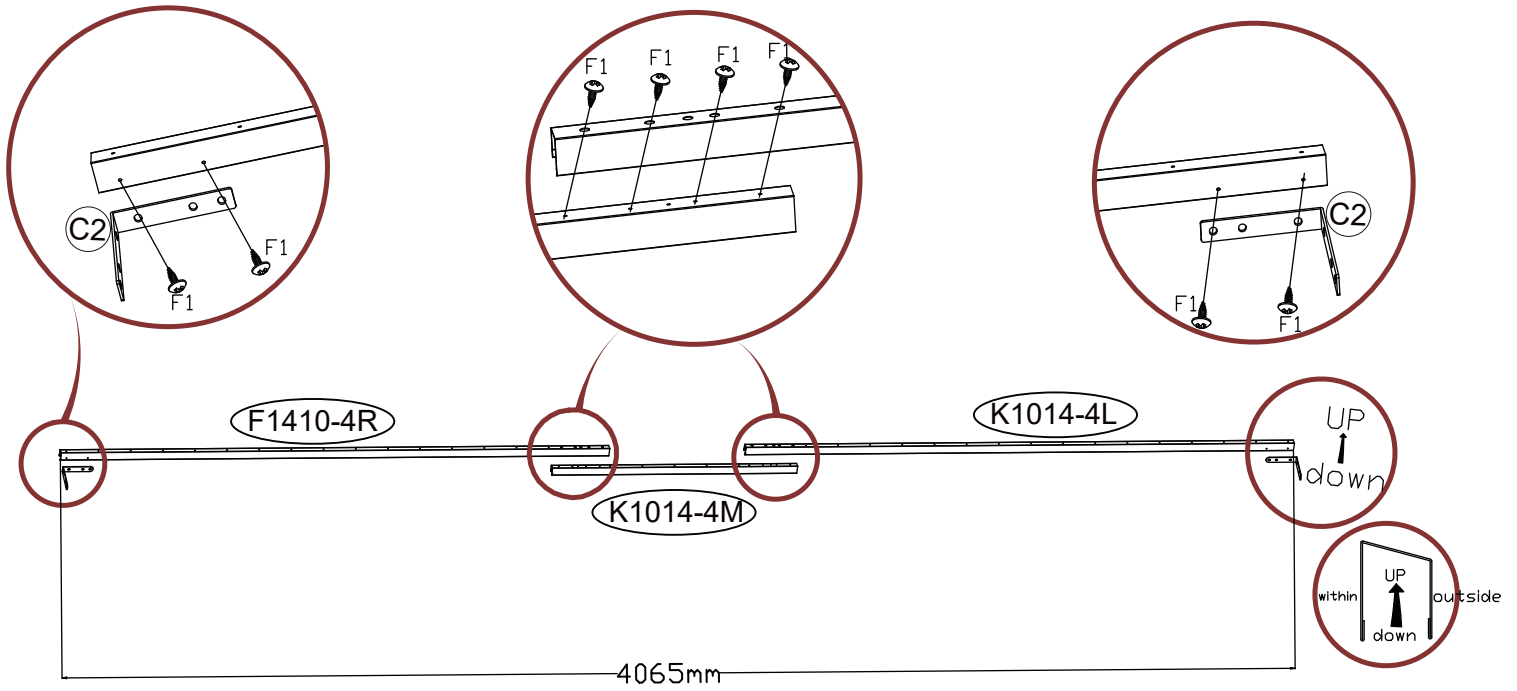
X2



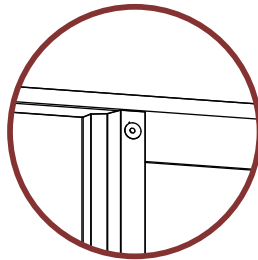
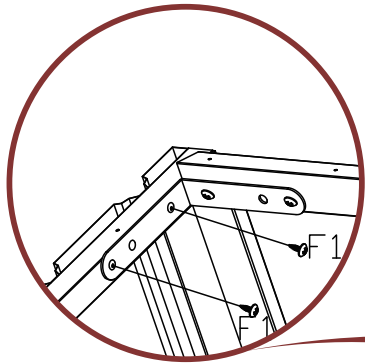
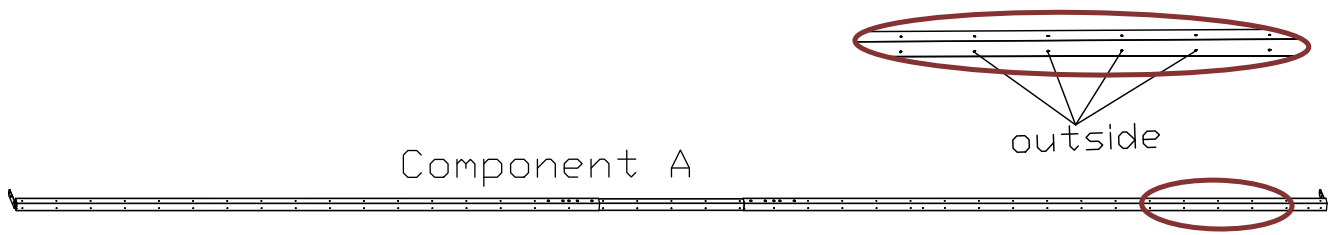

	F1	24
---	----	----

STEP 5

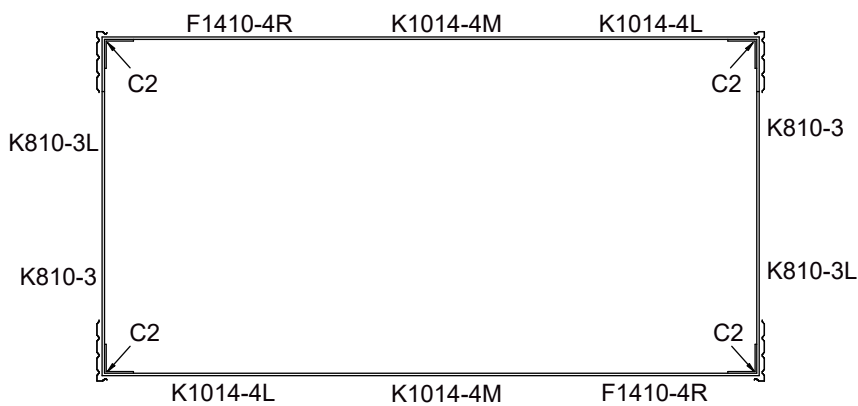

Do not add screws that indicated with an X in diagram. These need to be left undone.



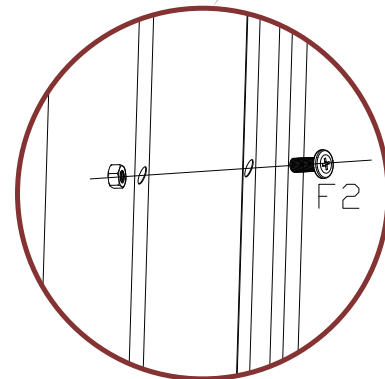
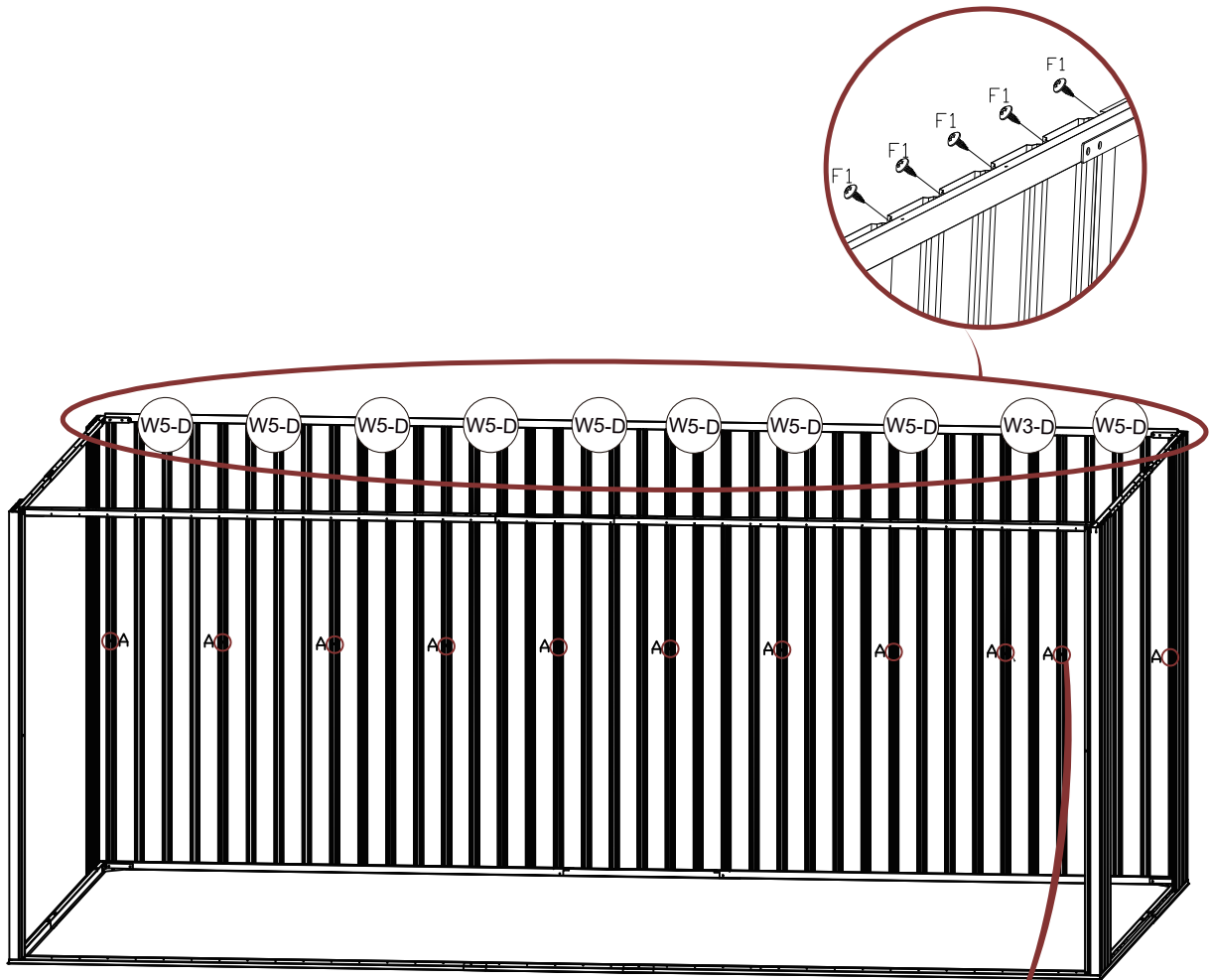

	F1	8
---	----	---

STEP 6

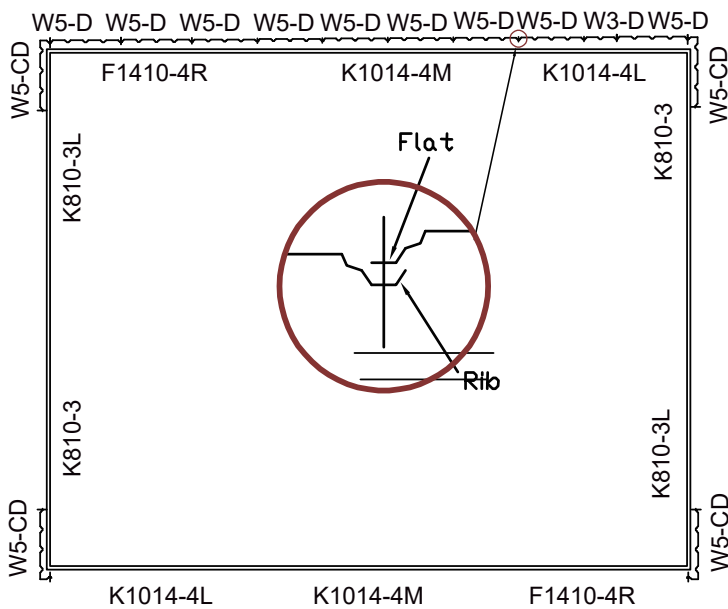

11*A





	F1	78
	F2	11

STEP 7

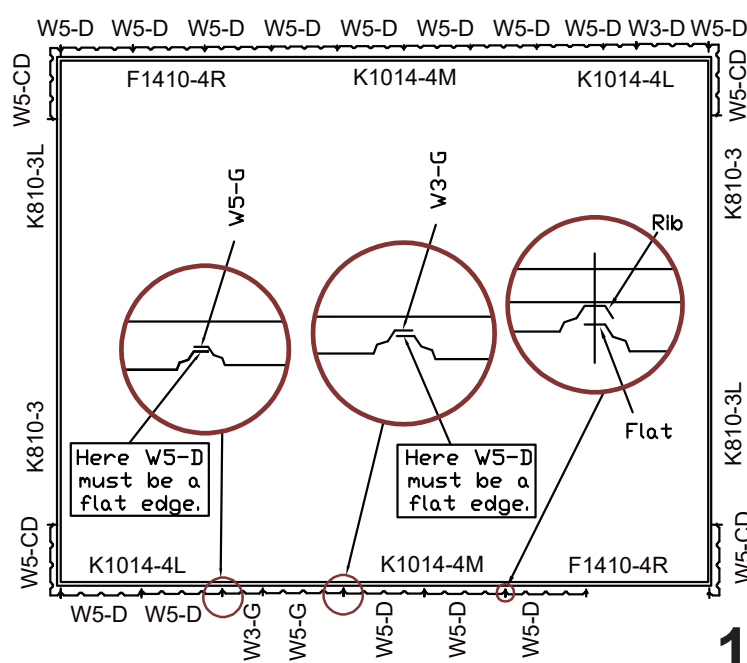
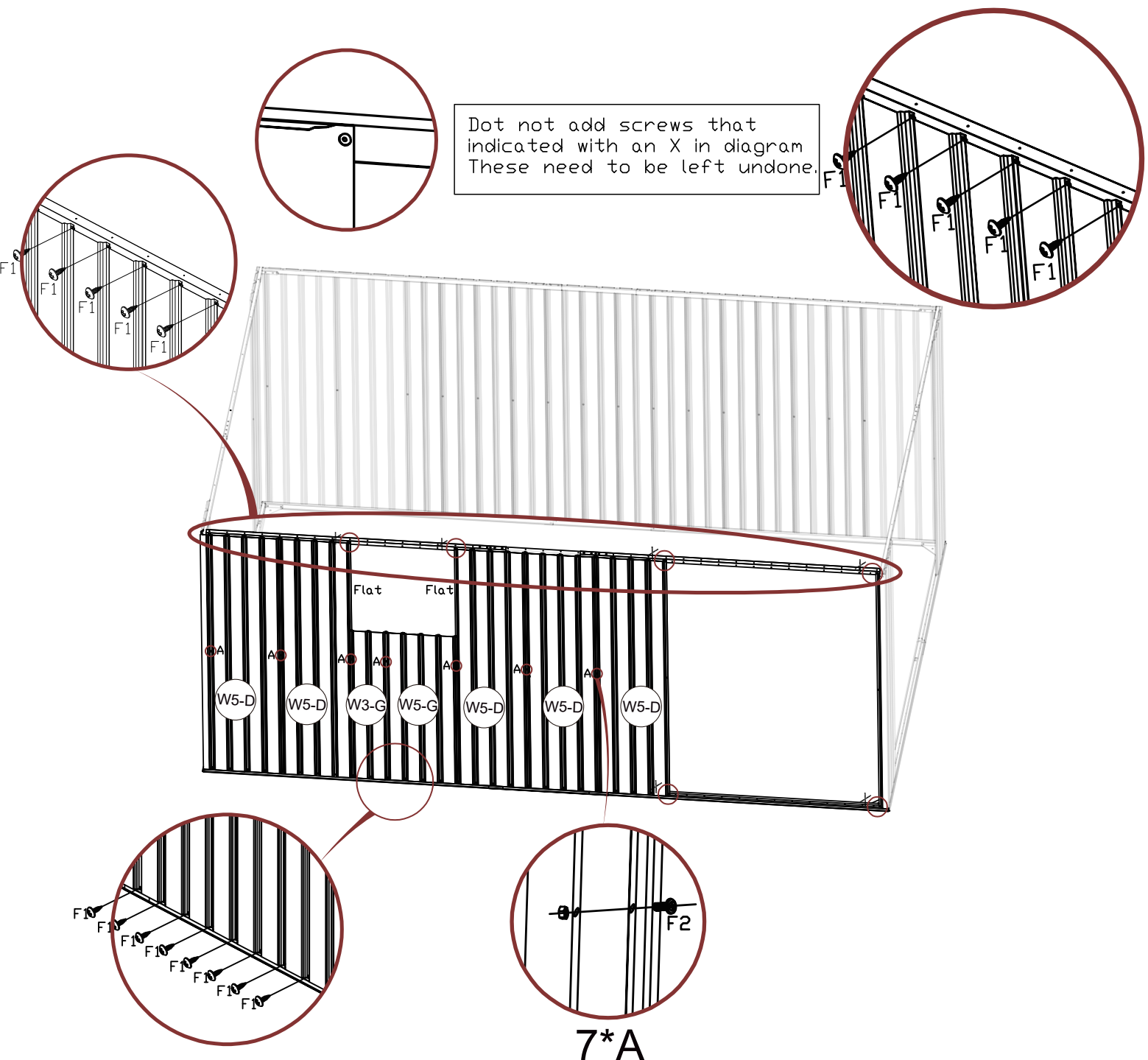
Do not add screws that indicated with an X in diagram. These need to be left undone.



	F1	45
	F2	7

STEP 10

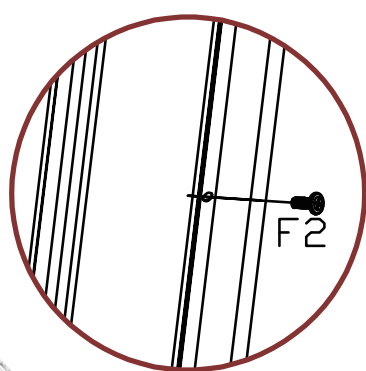
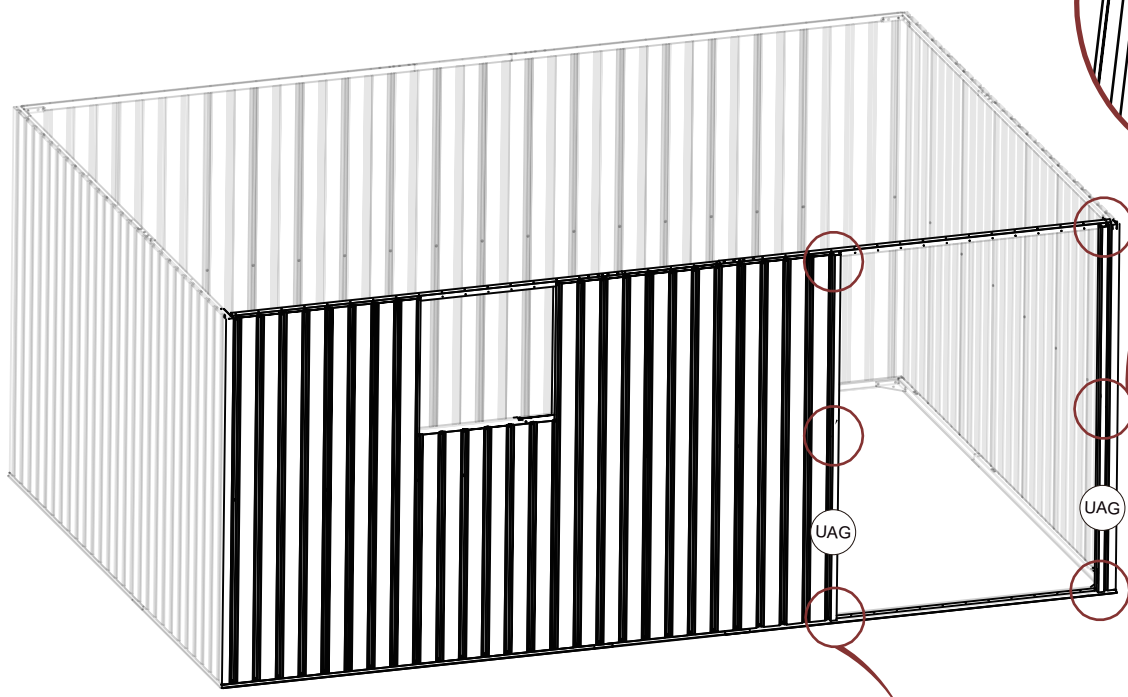

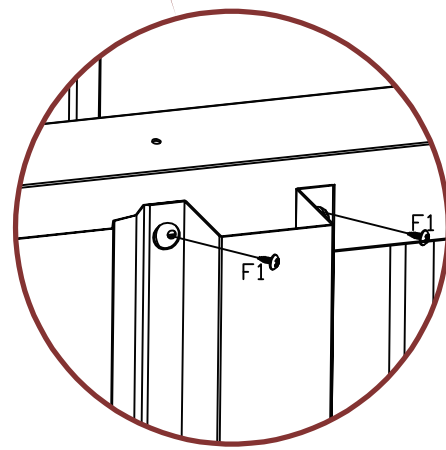

X2

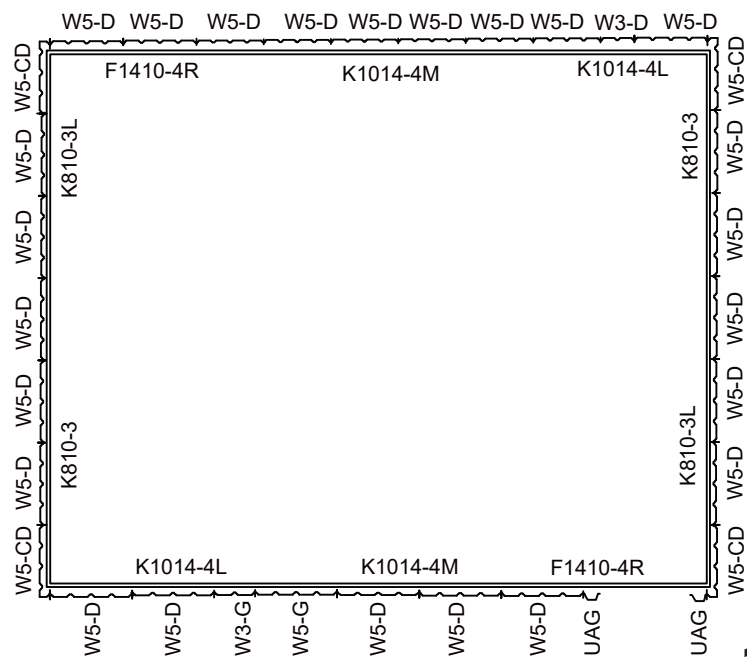

X4



	F1	8
	F2	2

STEP 11

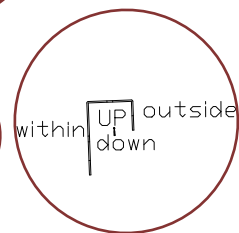
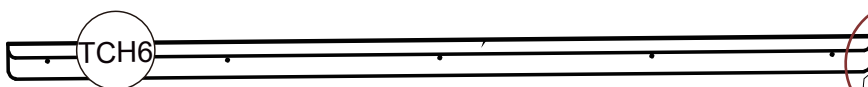
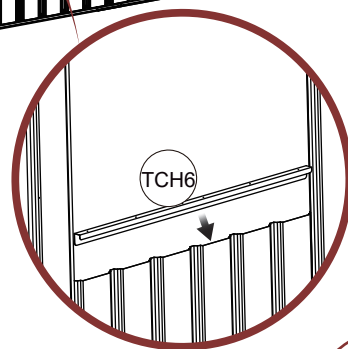
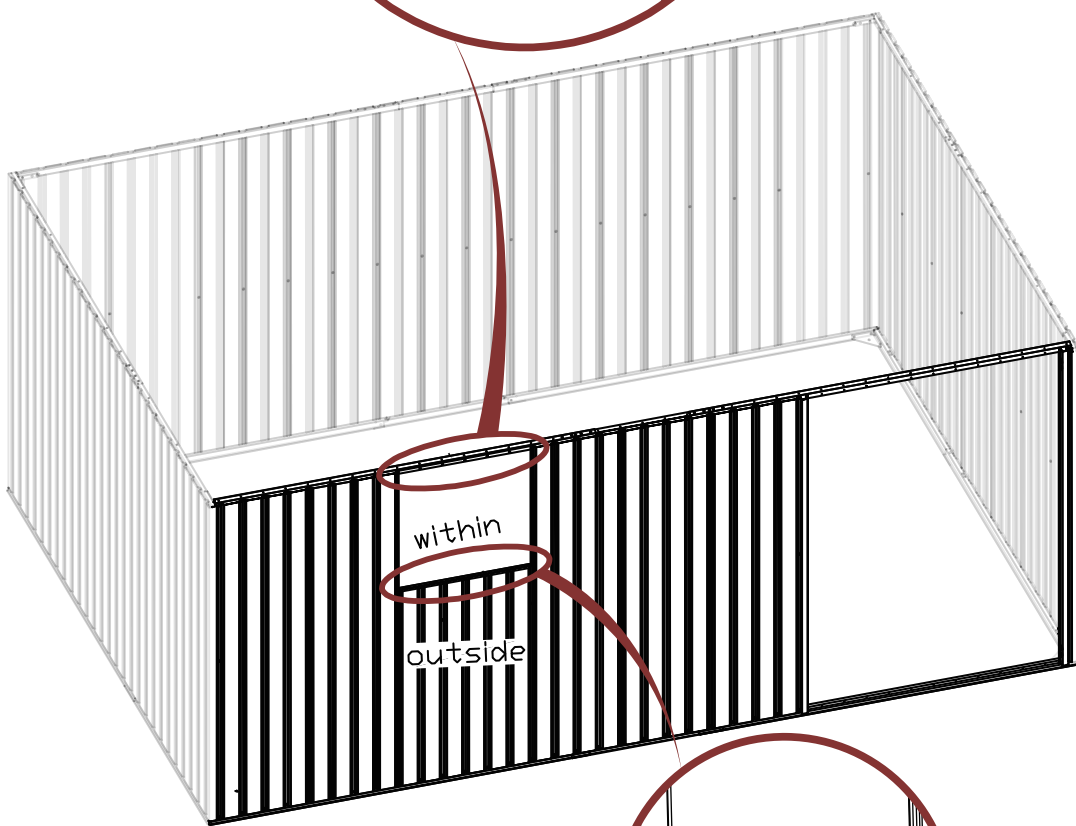
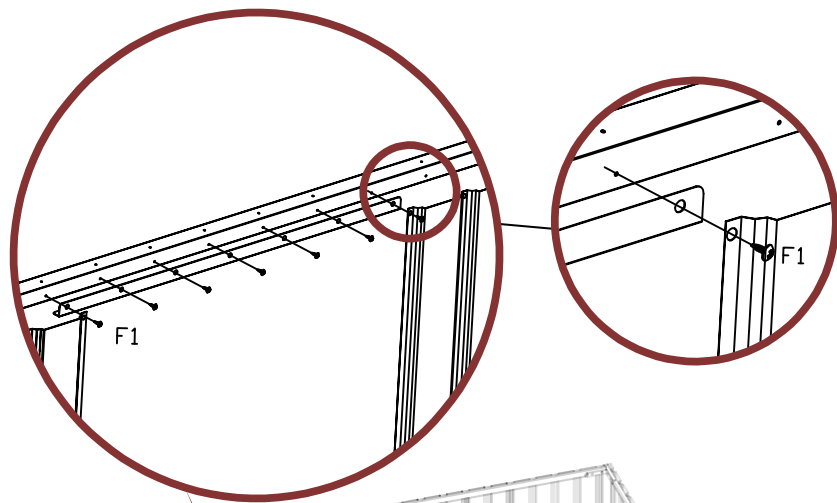
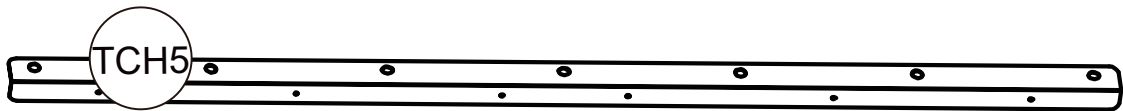

Installation method: Insert the TCH6 slot card into the W5-G and W3-G, with the long side facing inward. No screws are needed for fixation.

	F1	7
---	----	---

STEP 12

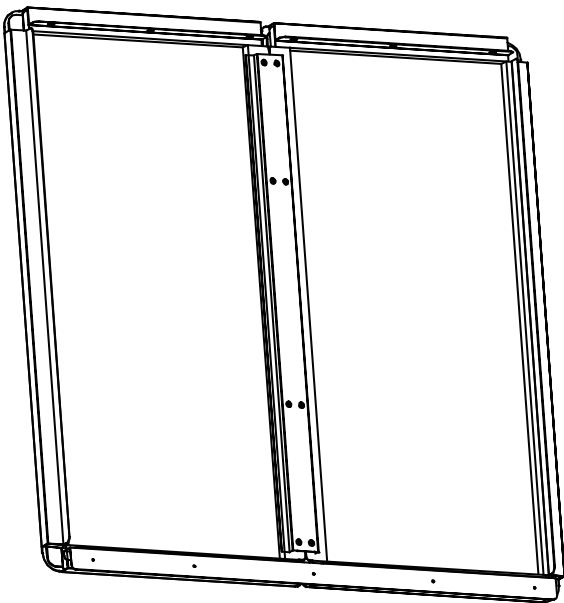
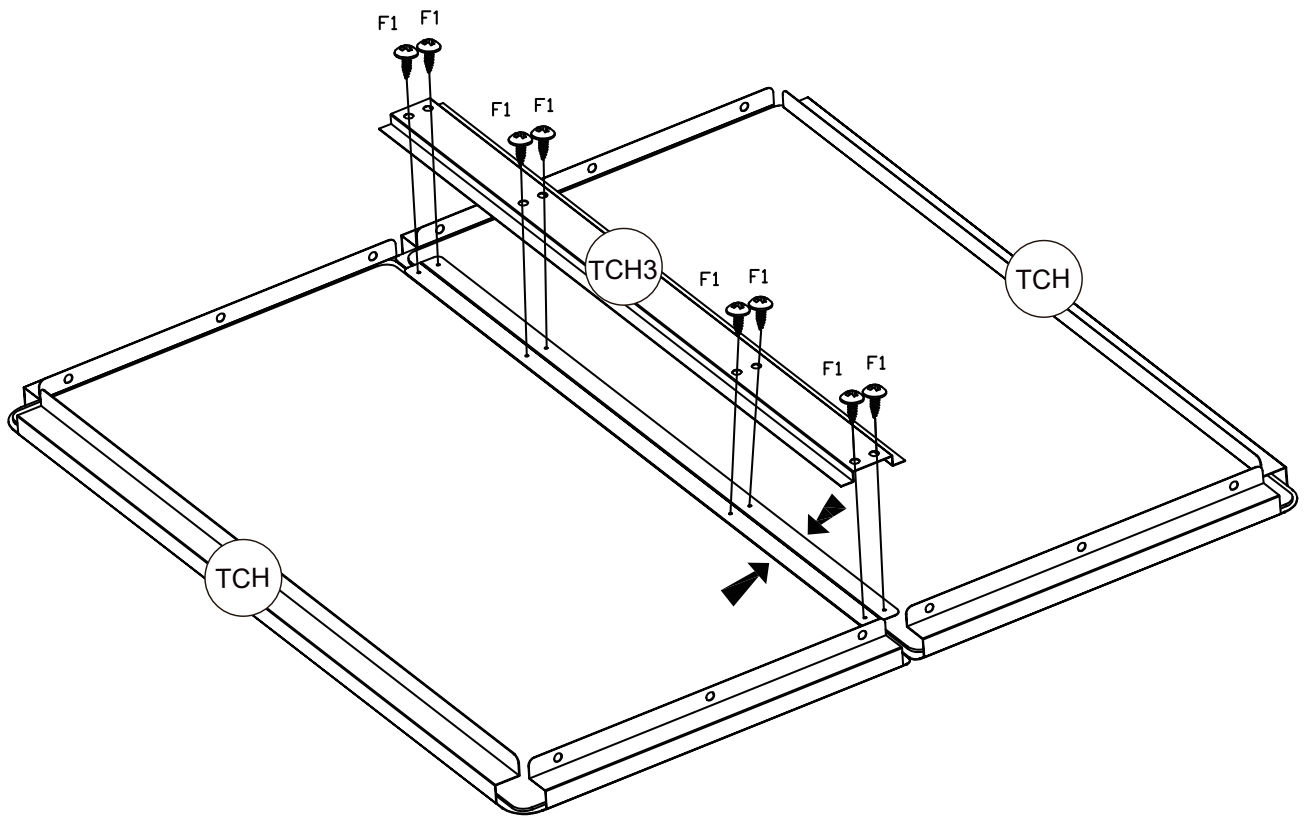

back

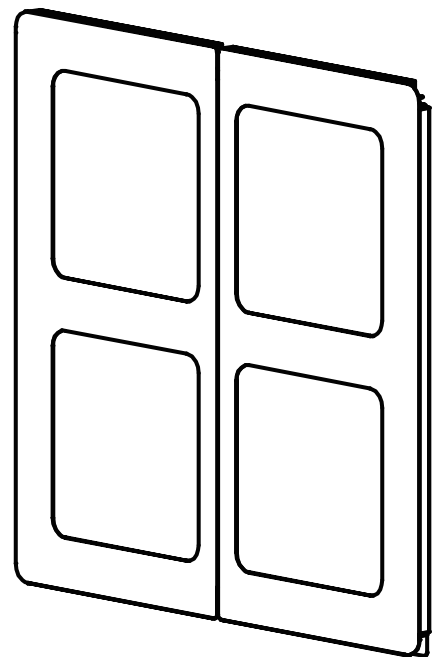

front

	F1	8
---	----	---

STEP 13

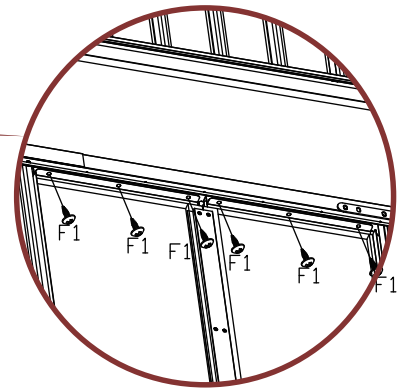
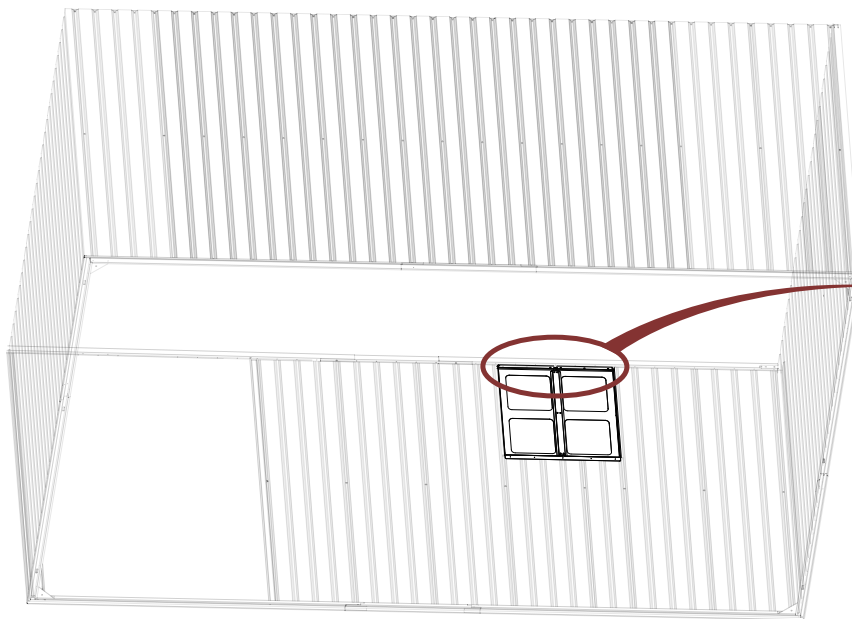
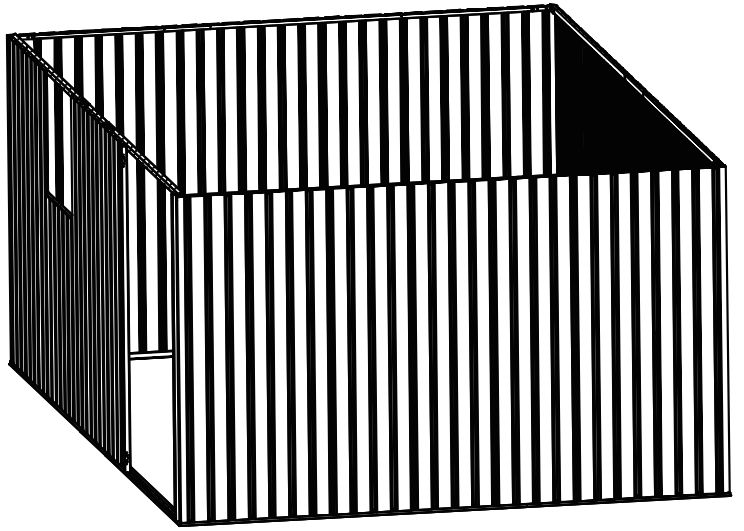
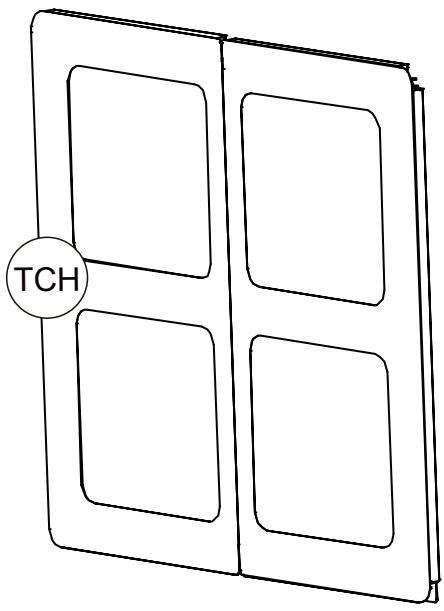

	F1	6
---	----	---

STEP 14

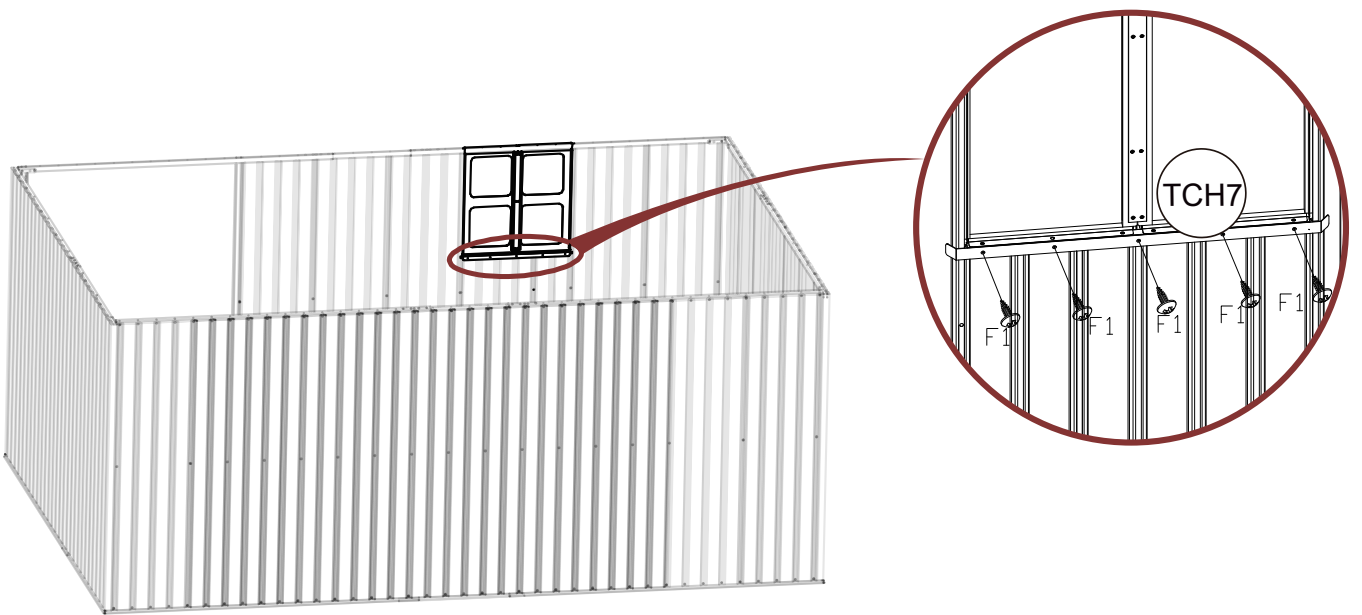
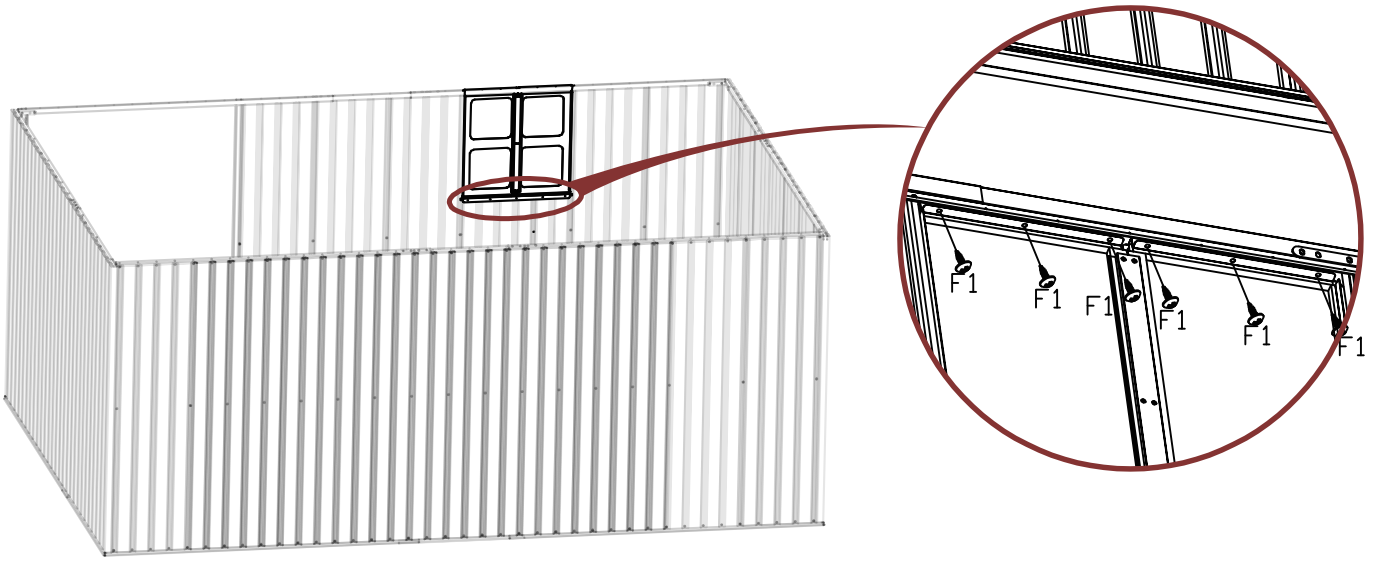

	F1	11
---	----	----

STEP 15

Attention: Assemble the ventilation board screws in the order shown in the diagram, Install the middle hole first to avoid misalignment.

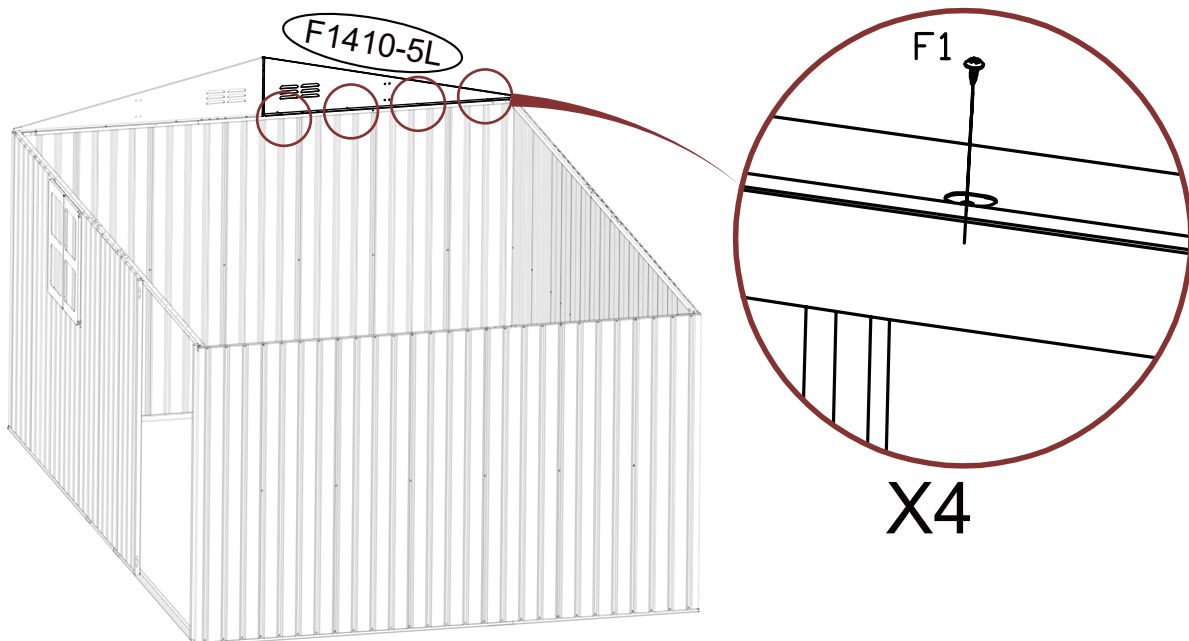
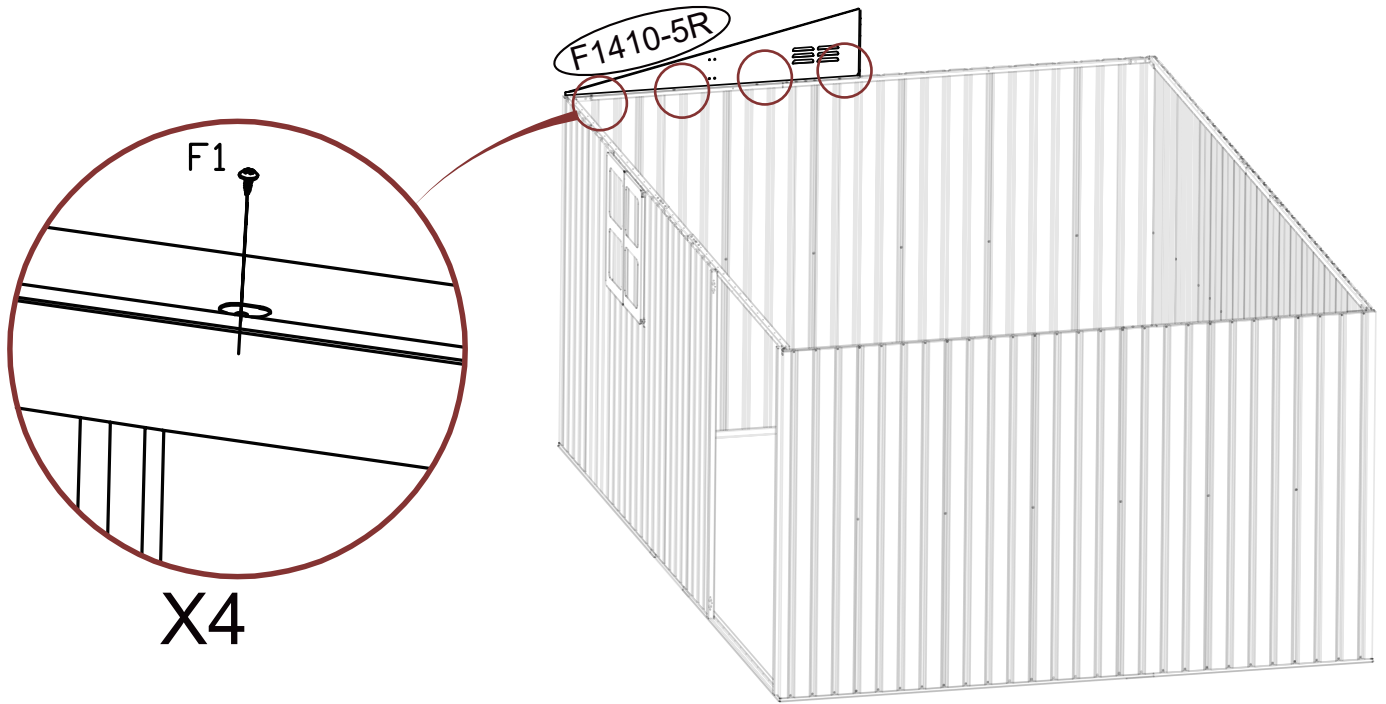

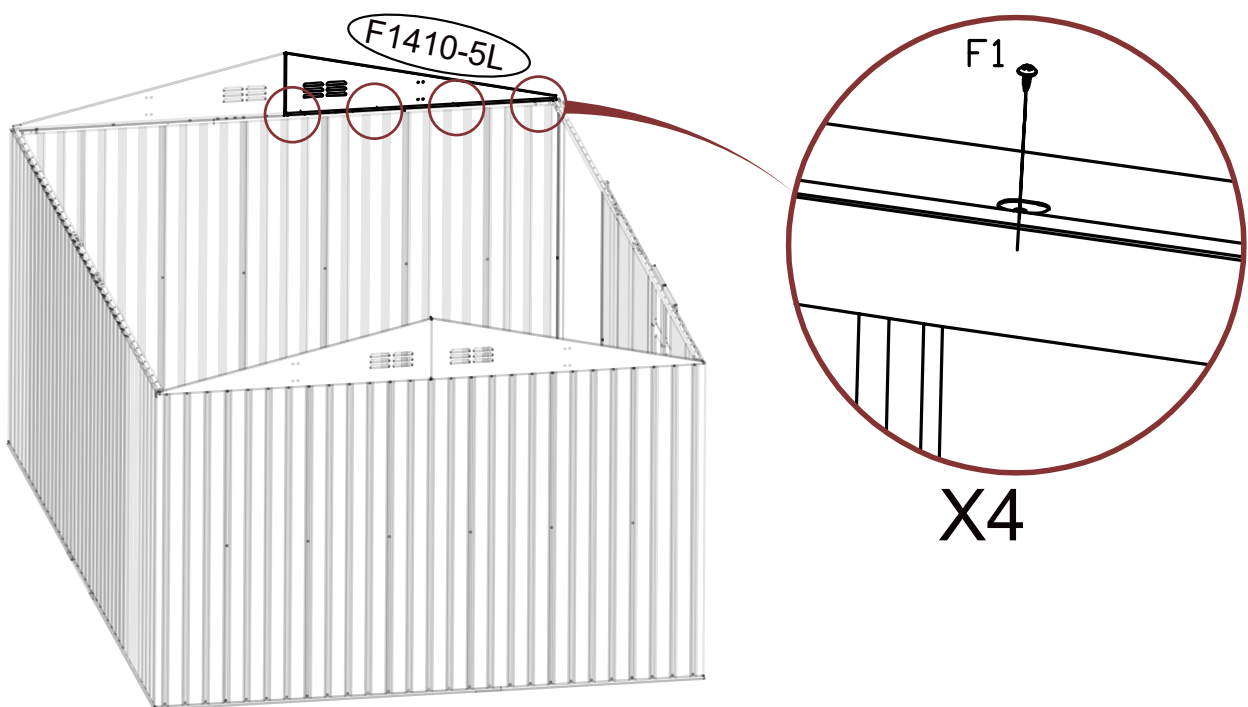
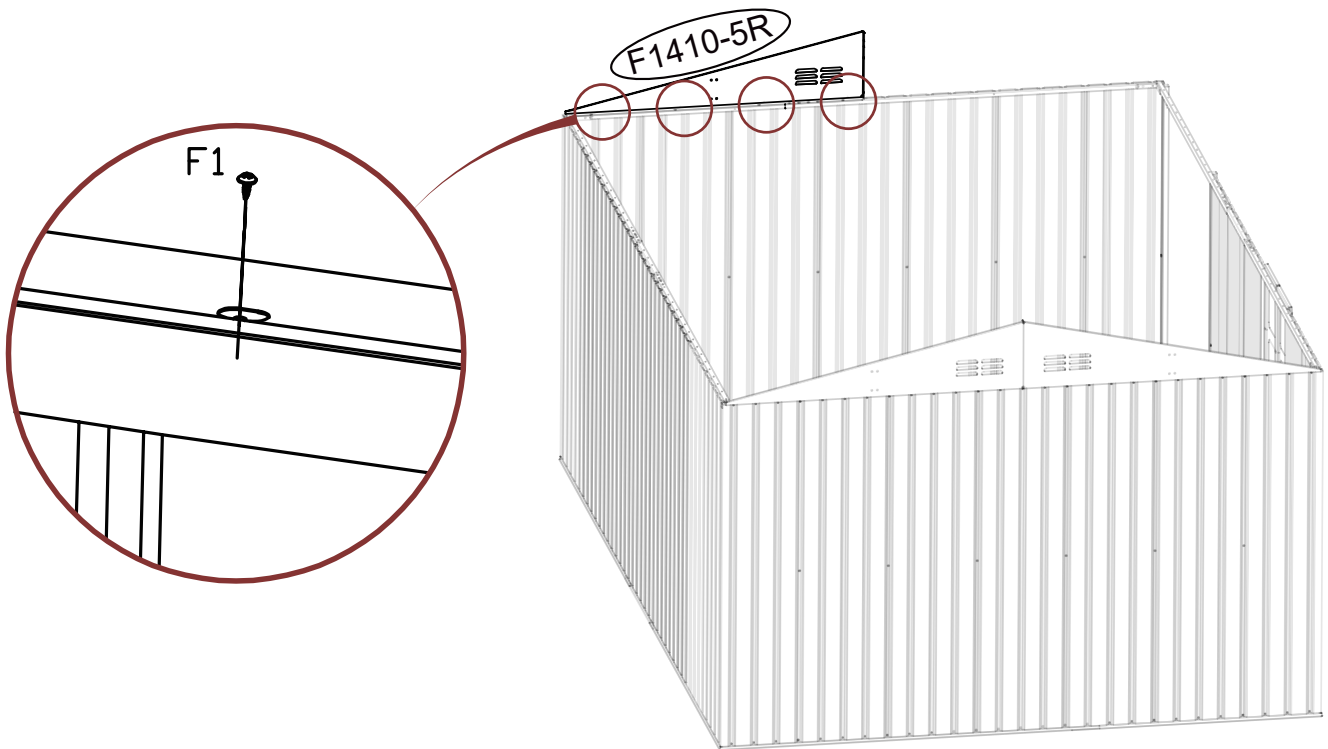

STEP 16

Attention: Assemble the ventilation board screws in the order shown in the diagram, Install the middle hole first to avoid misalignment.

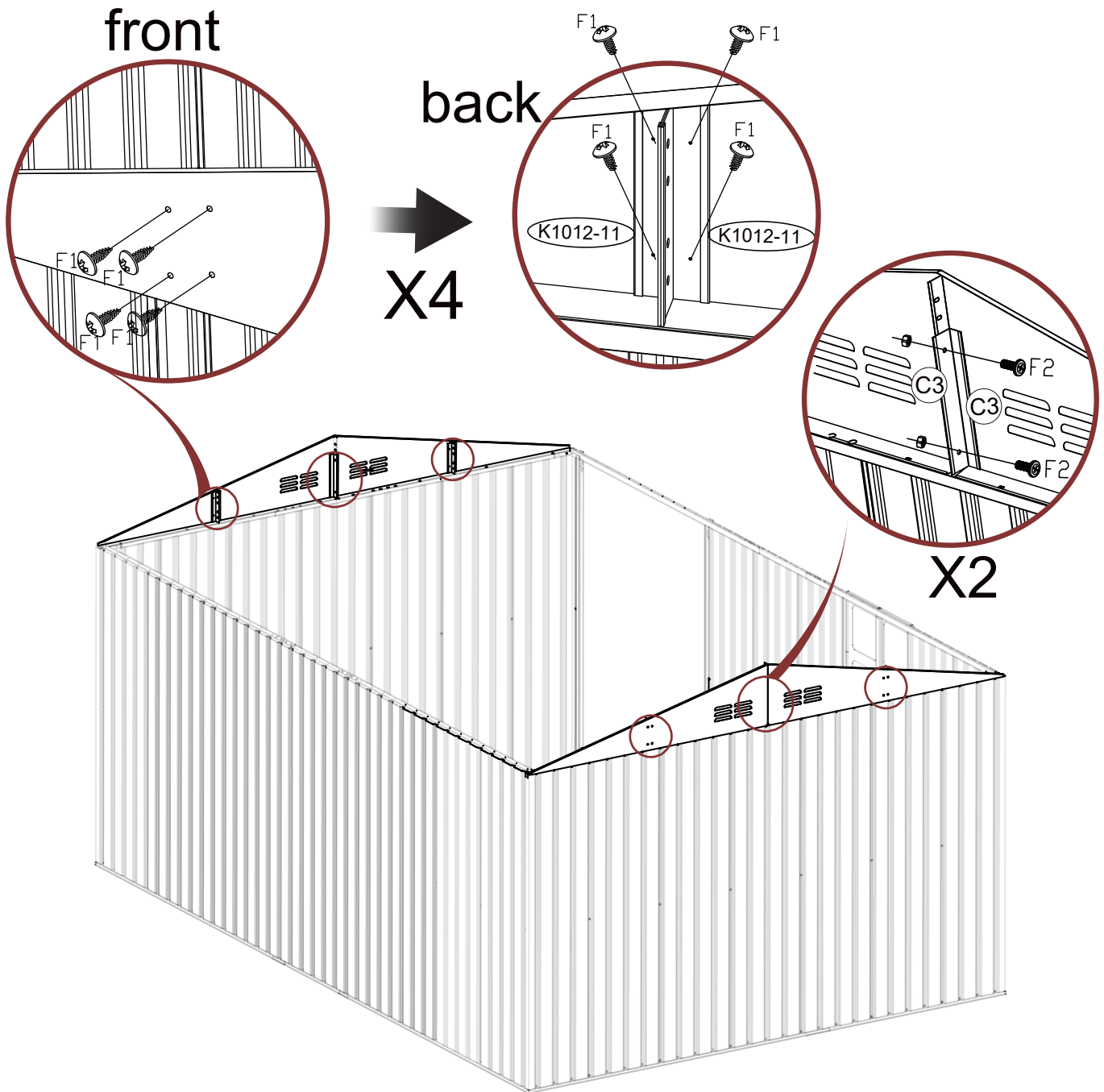

STEP 17



	F1	16
	F2	4

There are holes on top.

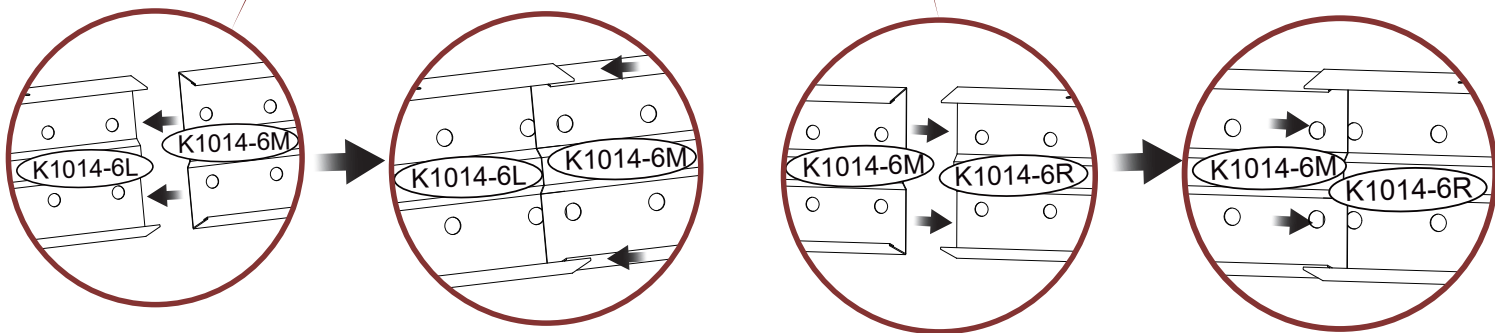
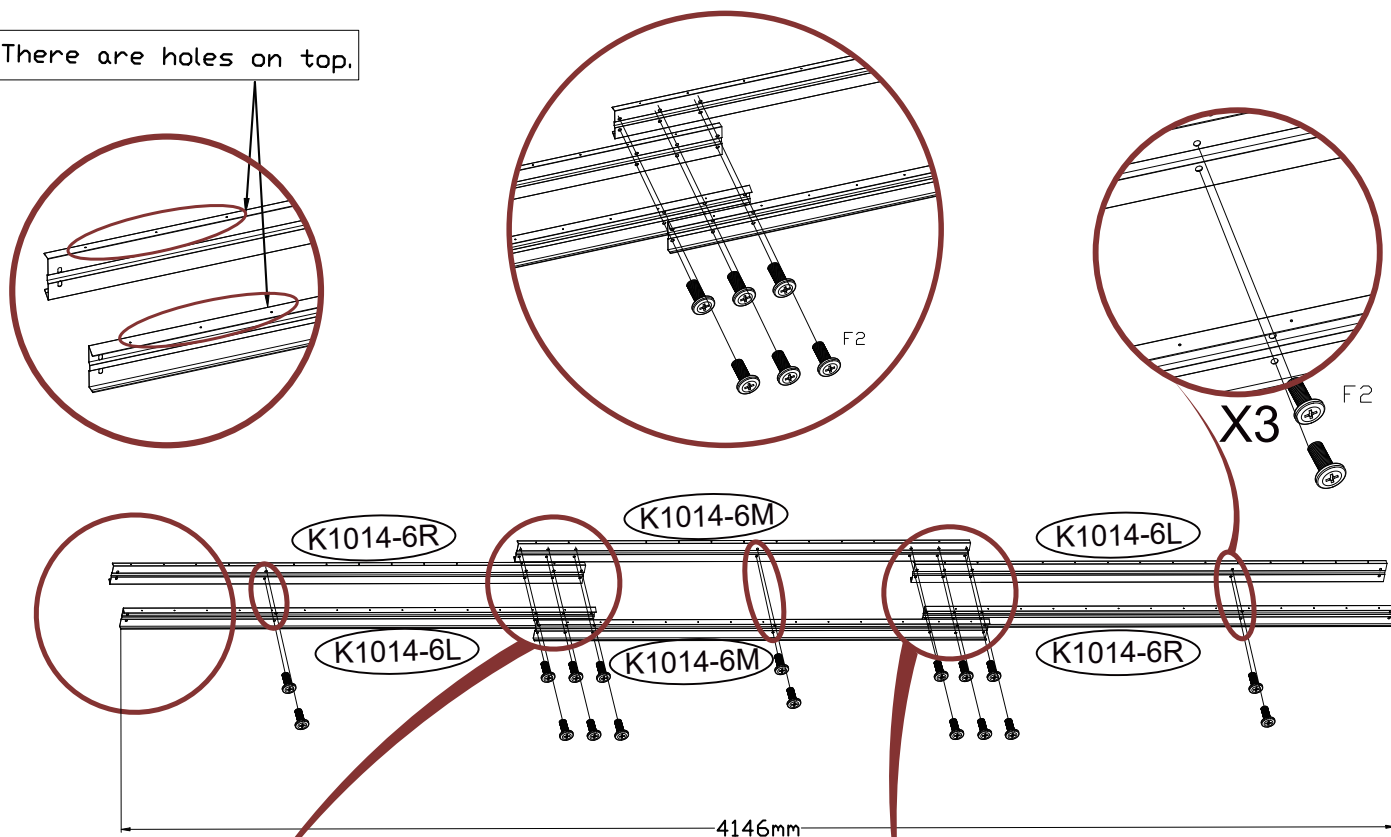

K1014-6M has a smaller width and can be fitted into K1014-6L. Align the holes with K1014-6R.

K1014-6M has a smaller width and can be fitted into K1014-6R.

	F2	54
---	----	----

STEP 19

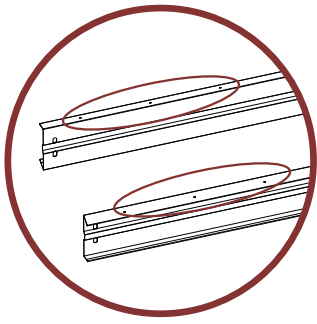

There are holes on top.

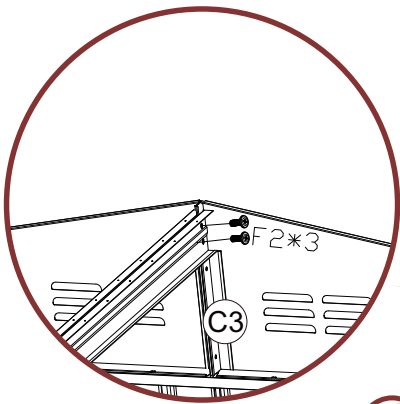
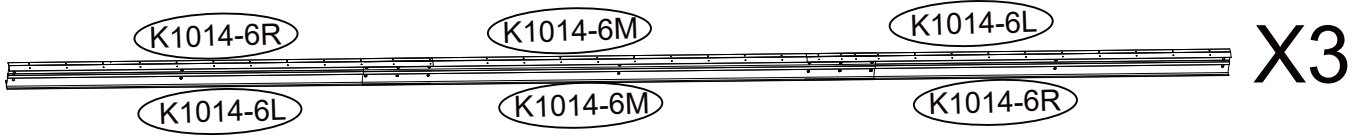

X2

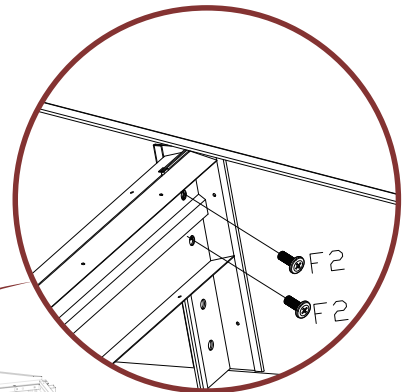

X4

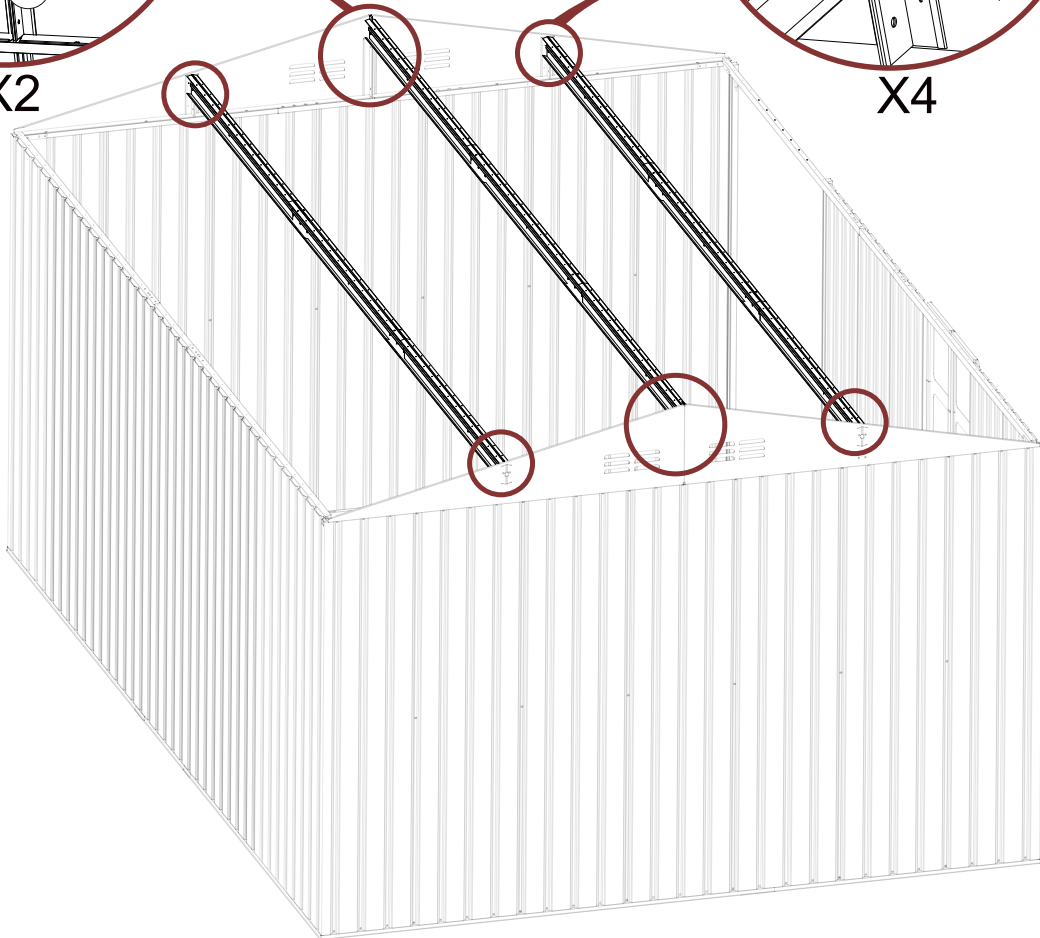

	F2	12
---	----	----

STEP 20

Pay attention to the installation dimensions of the top cover plate.

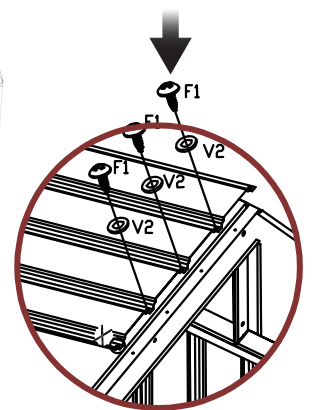
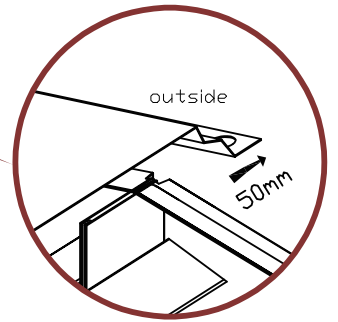
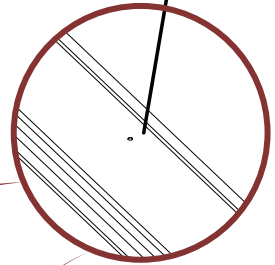
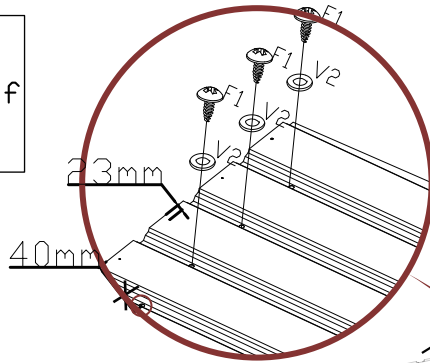

Attention: There are small holes on the outside for assembly with F1209-8.

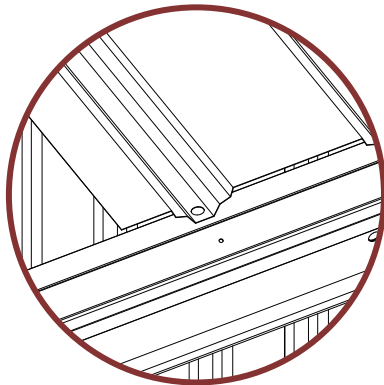

Install according to the diagram:
The edge extends outward by about 50mm.



Do not add screws that indicated with an X in diagram. These need to be left undone.

	F1	6
	V2	6

STEP 21

F1209-7R F1209-7M F1209-7M F1209-7M F1209-7M F1209-7M F1209-7M F1209-7M F1209-7L

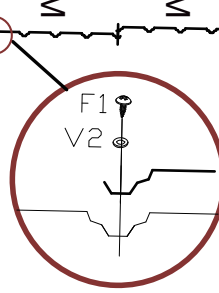
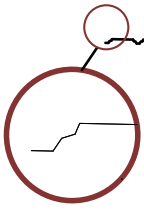

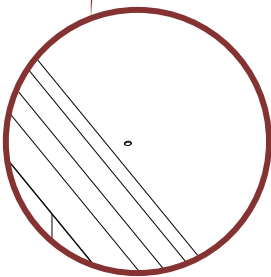
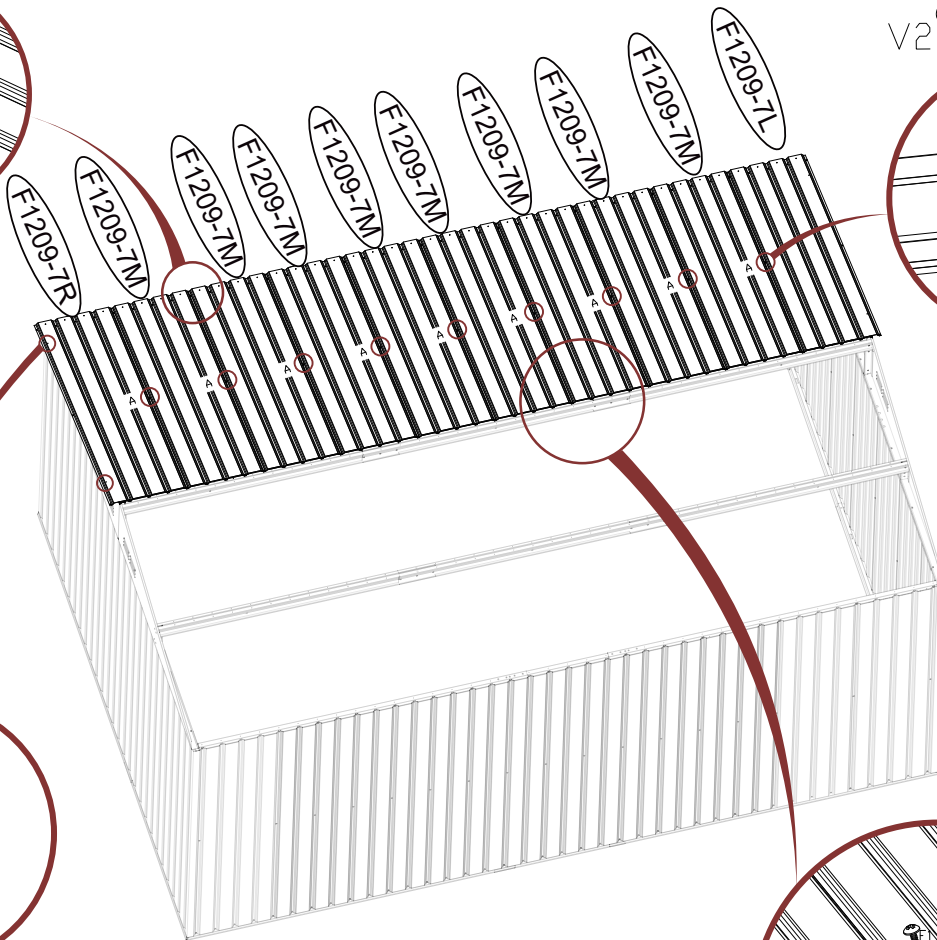
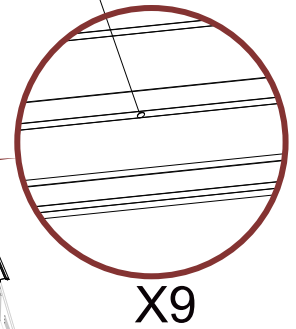
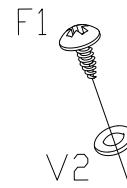
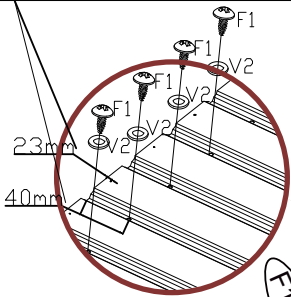

This is the installation of flat edges and F1209-8, otherwise, there will be interference phenomena.

Pay attention to the installation dimensions of the top cover plate.

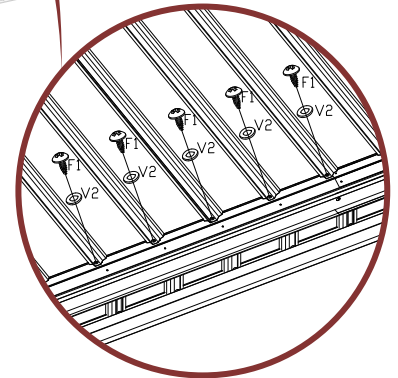

Attention: There are small holes on the outside for assembly with F1209-8.



	F1	81
	V2	81

STEP 22

F1209-7L F1209-7M F1209-7M F1209-7M F1209-7M F1209-7M F1209-7M F1209-7M F1209-7M F1209-7R

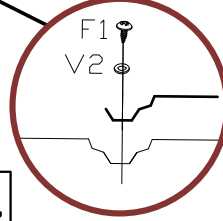
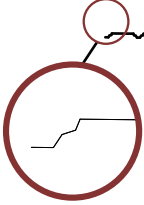

This is the installation of flat edges and F1209-8, otherwise, there will be interference phenomena.

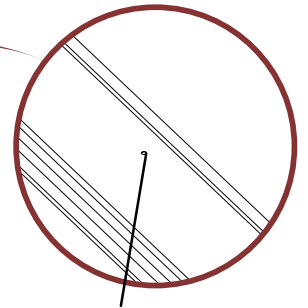
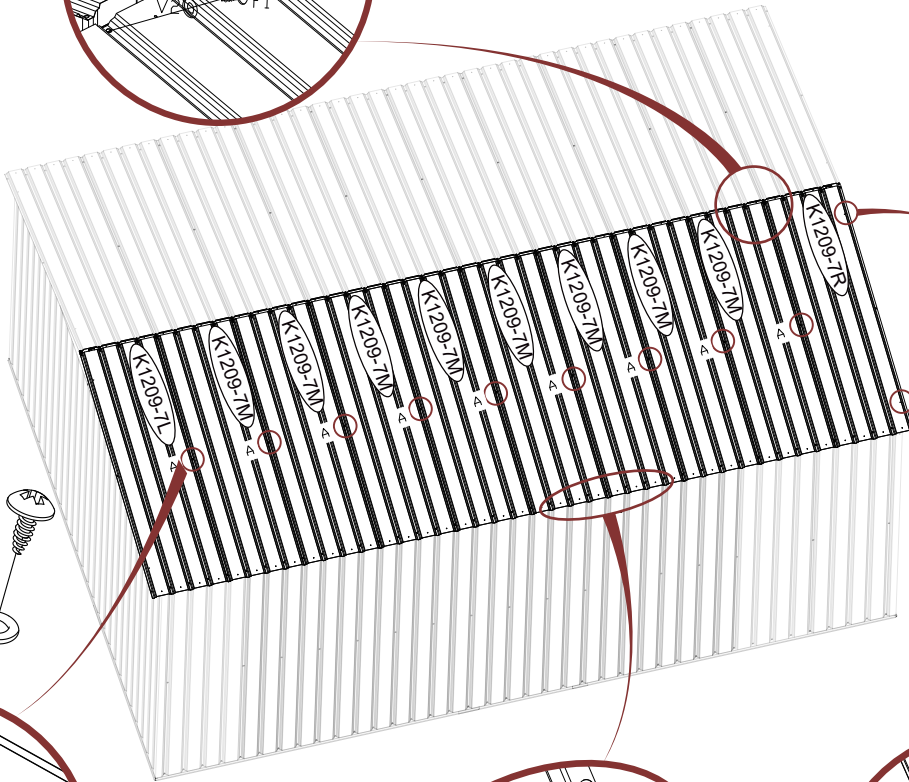
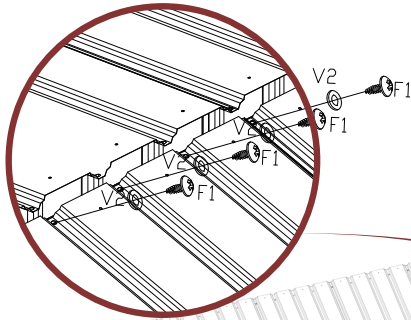

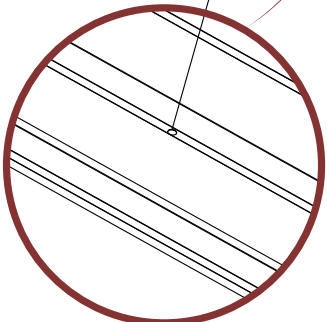
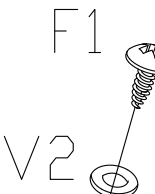

Attention: There are small holes on the outside for assembly with F1209-8.

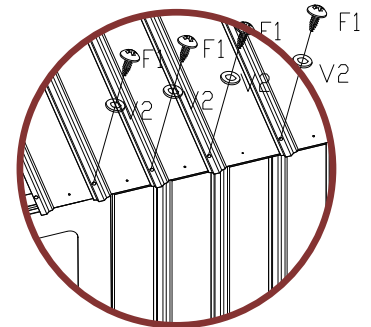
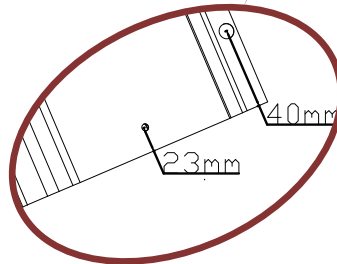

X9





Pay attention to the installation dimensions of the top cover plate.

	F1	87
	V2	87

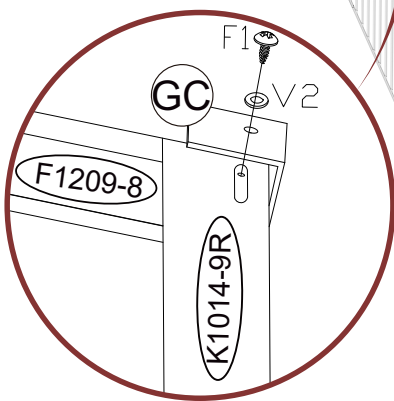
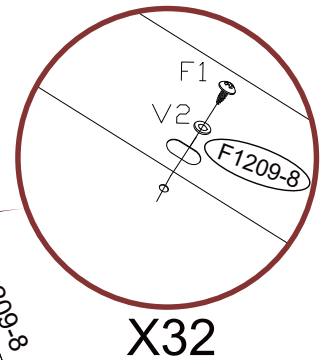
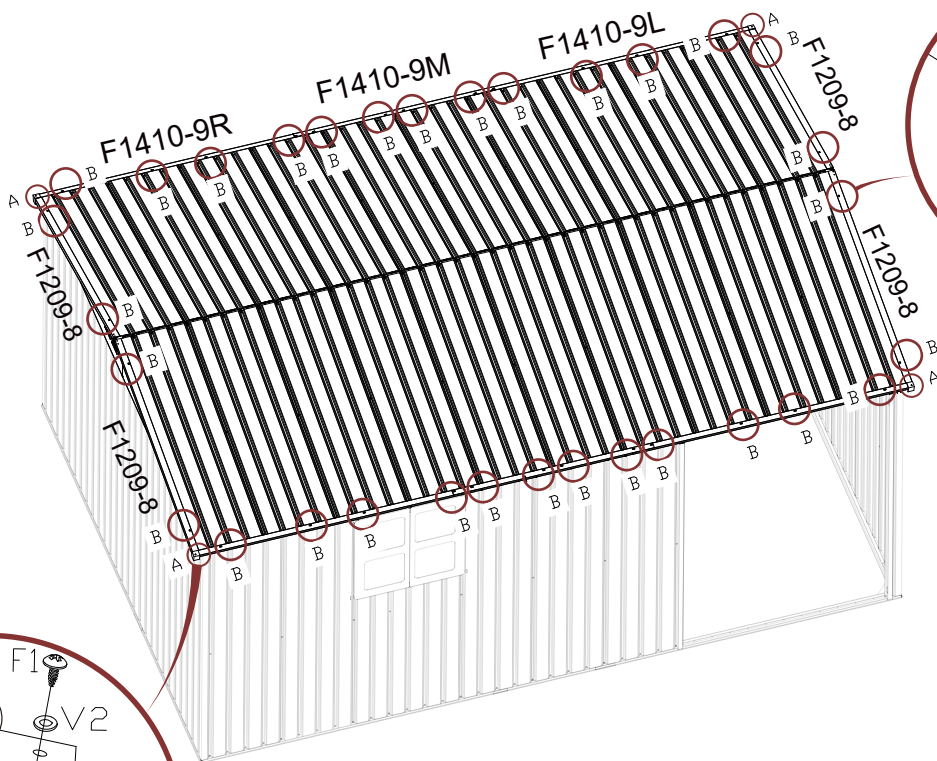
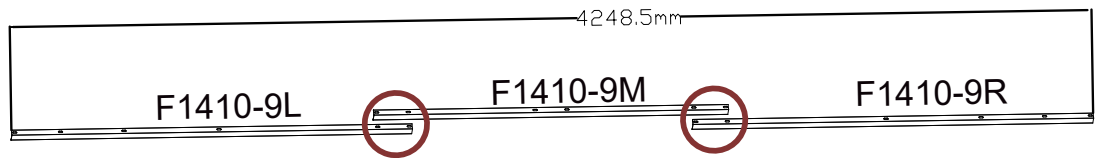
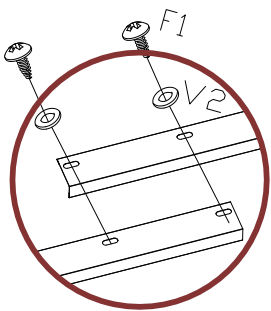
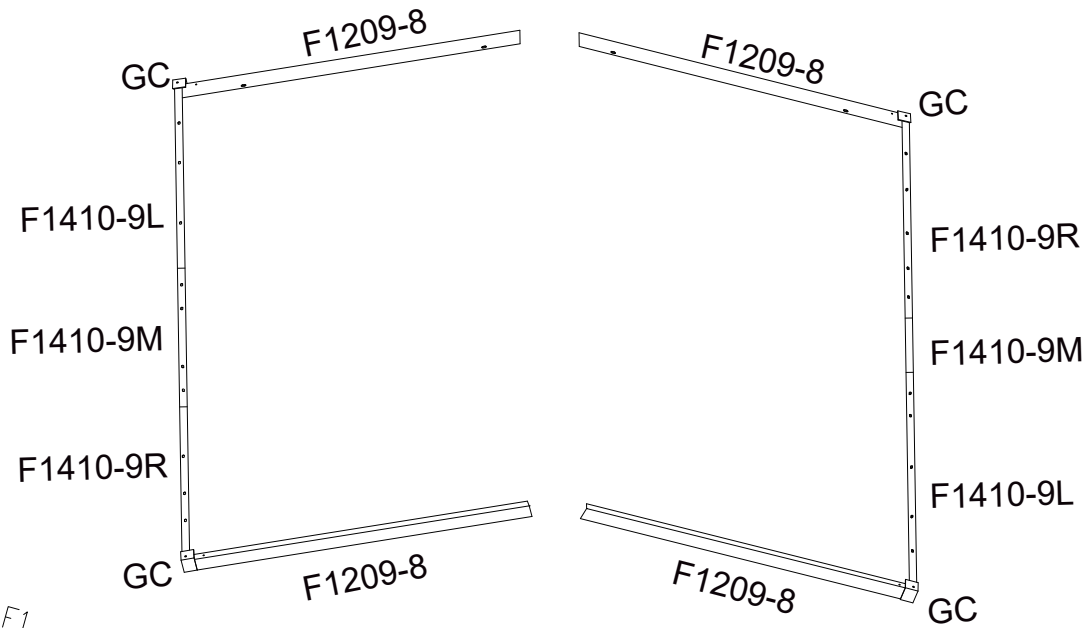
STEP 23



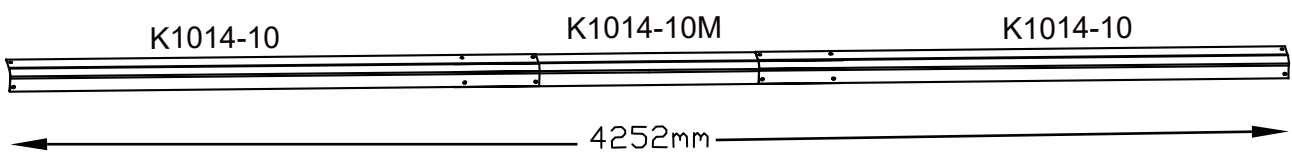
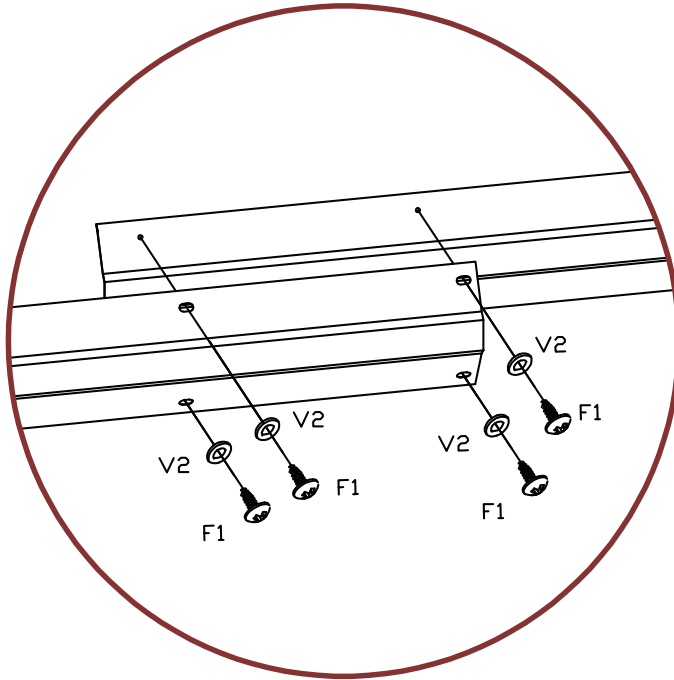
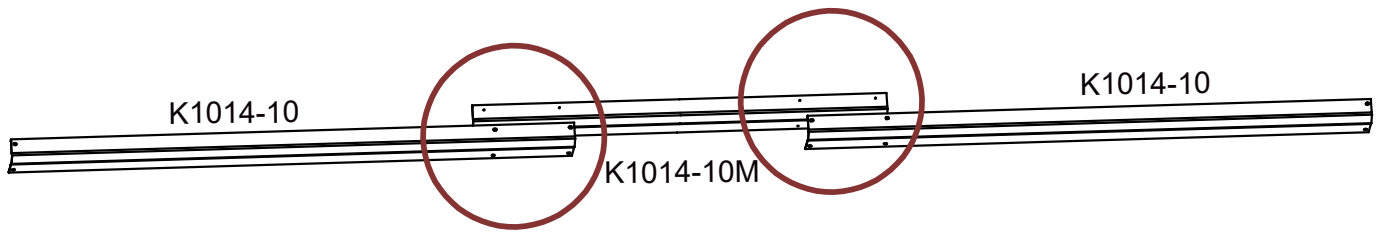

	F1	36
	V2	36

STEP 24





According to the diagram,
the three components of the roof rain shield
should be connected with F1 self tapping screws
before proceeding with subsequent installation

	F1	8
	V2	8

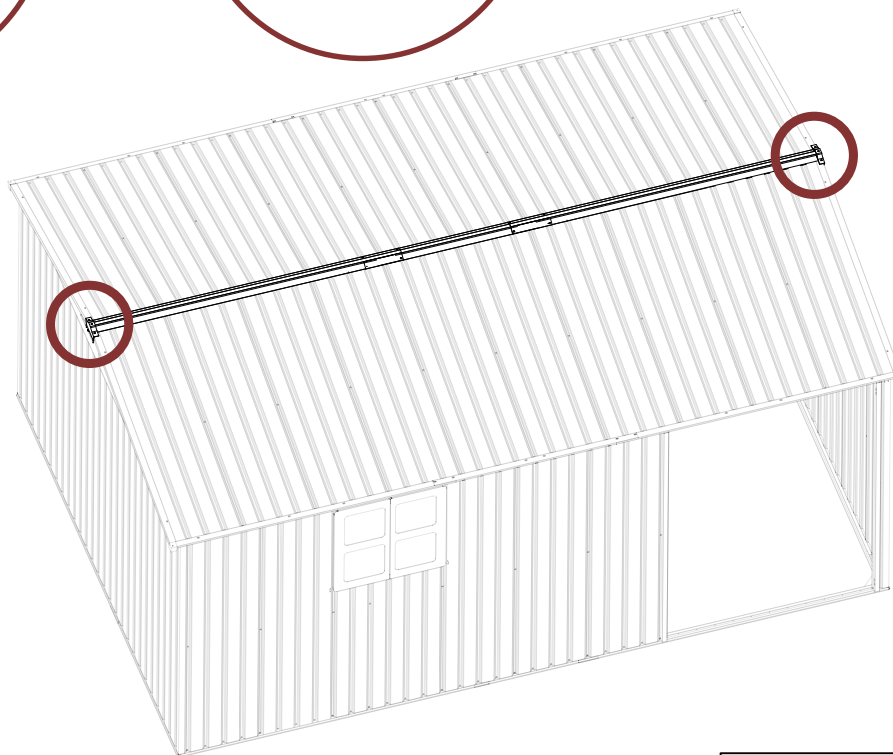
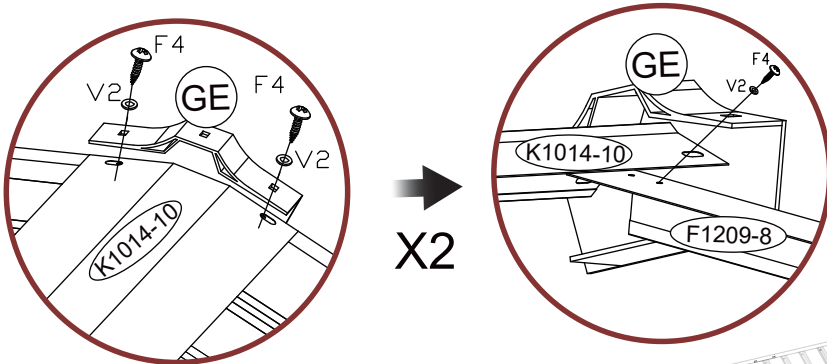
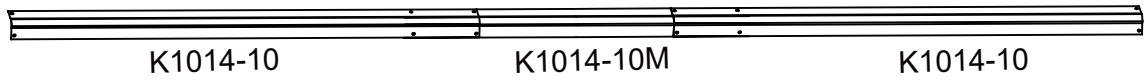
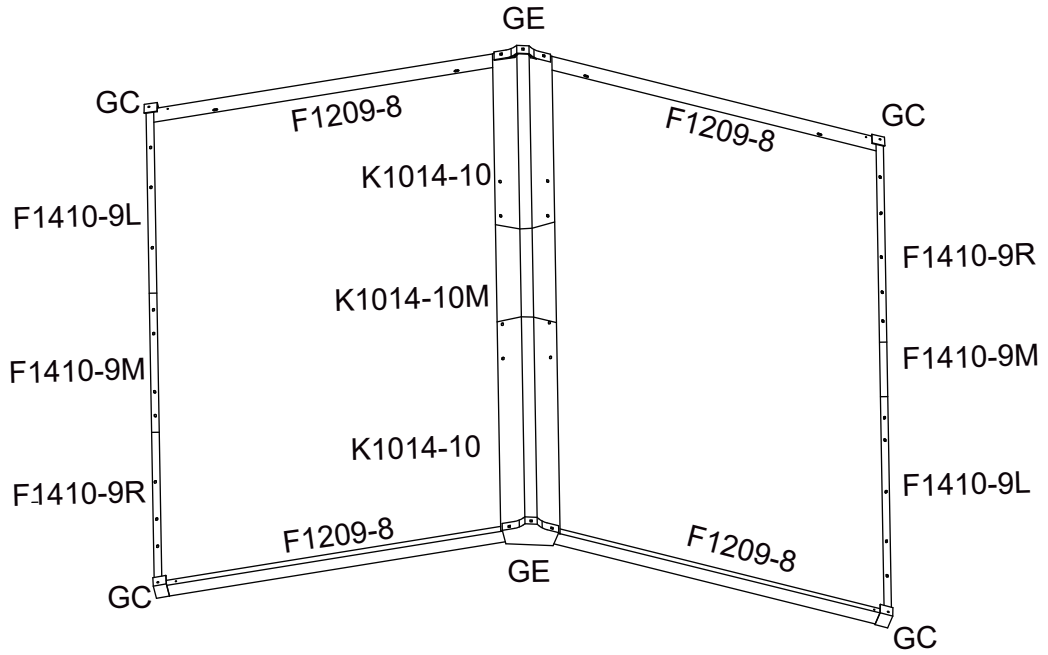
STEP 25



	F4	4
	V2	4

STEP 26

Left door panel splicing

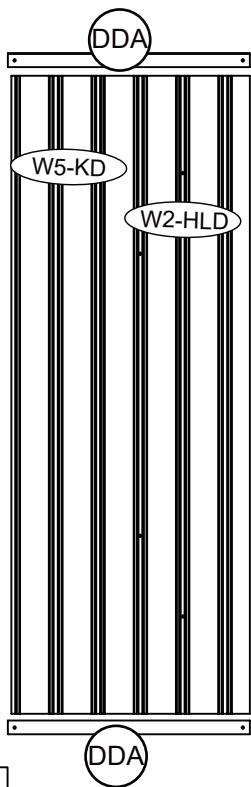
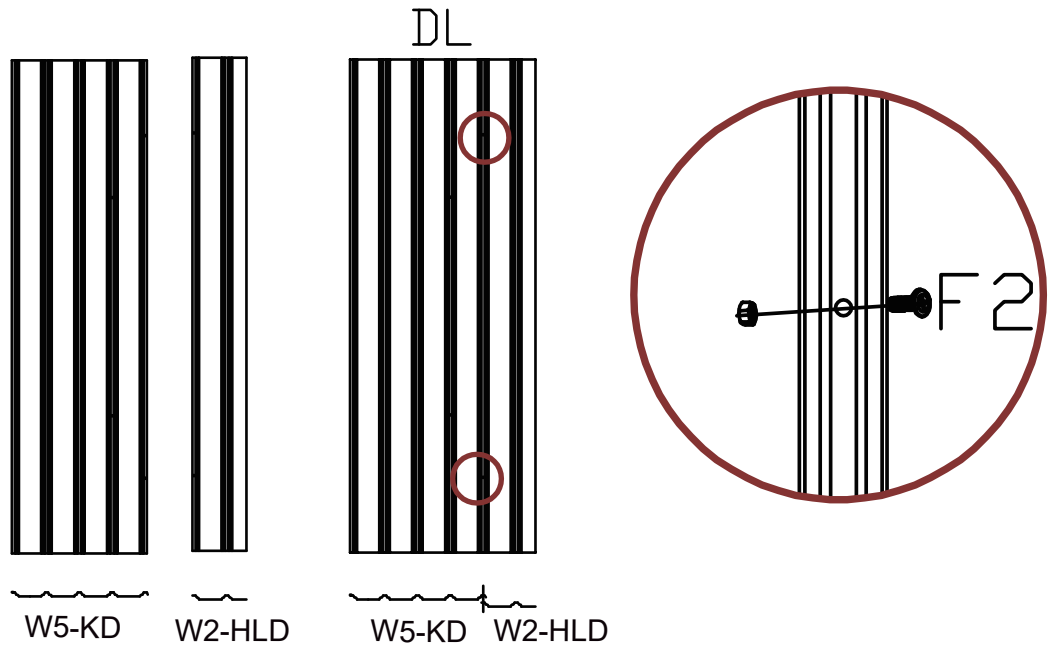

Front color-coated surface

narrow edge

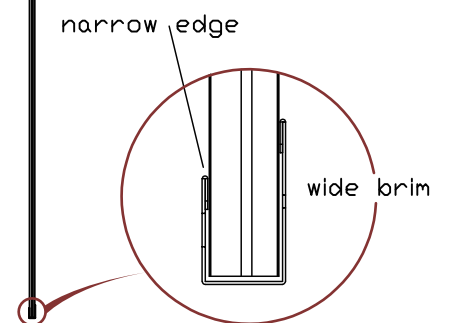
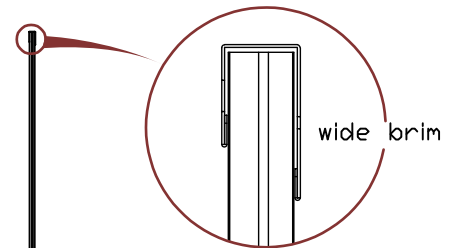
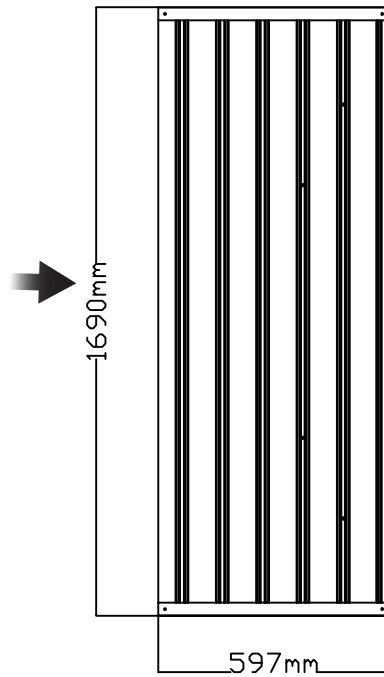

The door panel W2-HLD and W5-KD snap into the DDA slot.

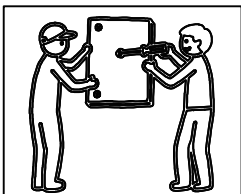

This step requires two people to complete the installation together.

	F2	2
---	----	---

STEP 27

Left door panel splicing

positive

Front color-coated surface

Big hole on the outside, small hole on the inside, connected with an F1 screw.

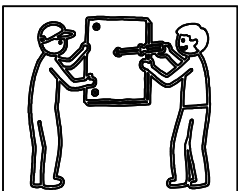
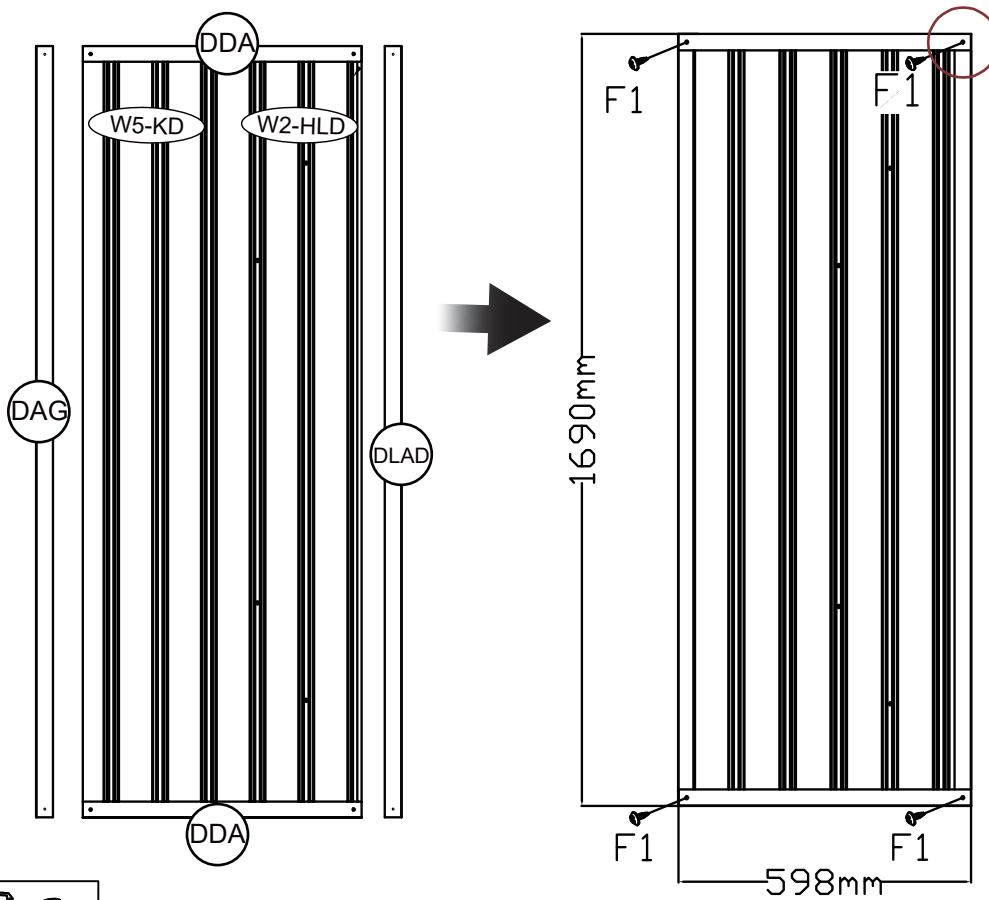
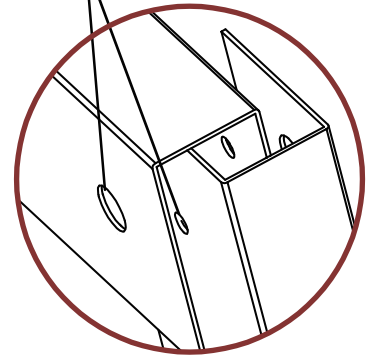
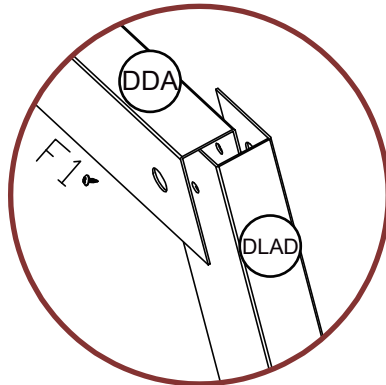
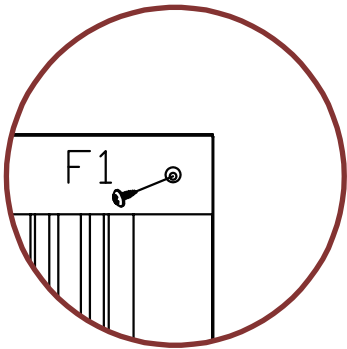

This step requires two people to complete the installation together.

	F4	4
---	----	---

STEP 28

Left door panel splicing

F1: ① ② ③ ④ ⑤

upper-DAG/DLAD

middle-DDA

under-DBD

back

F2: ⑥ ⑦

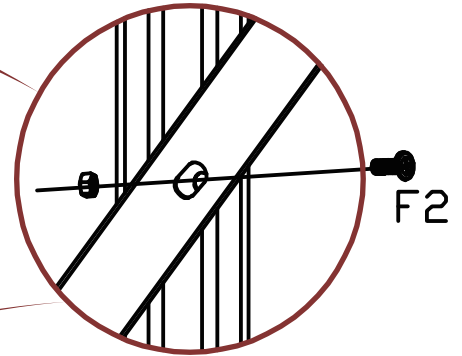
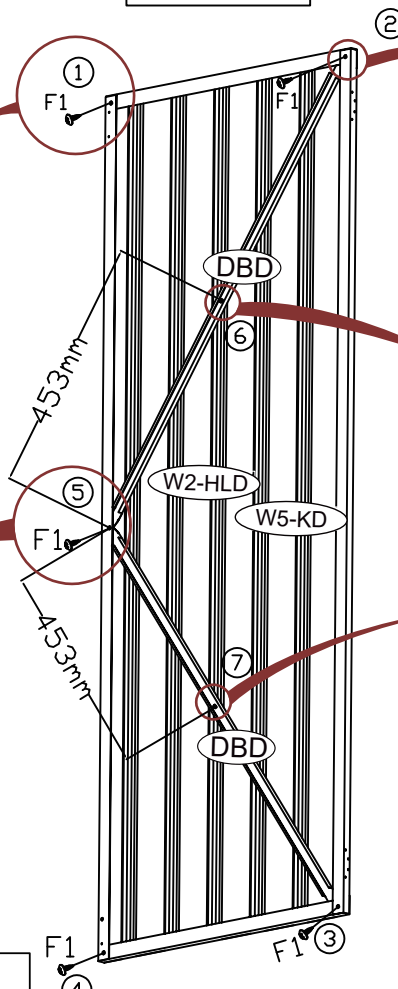
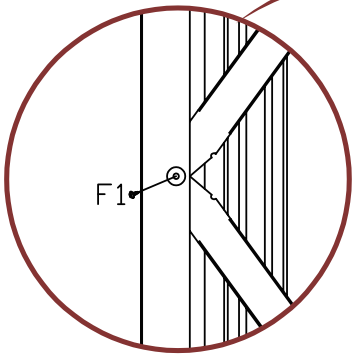
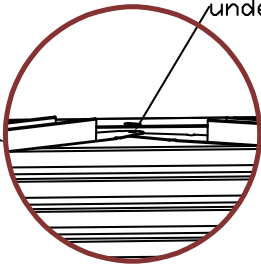
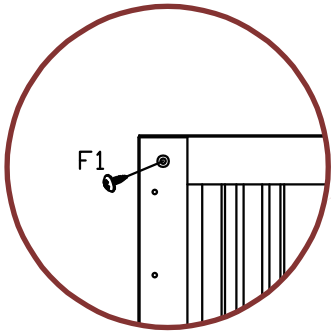

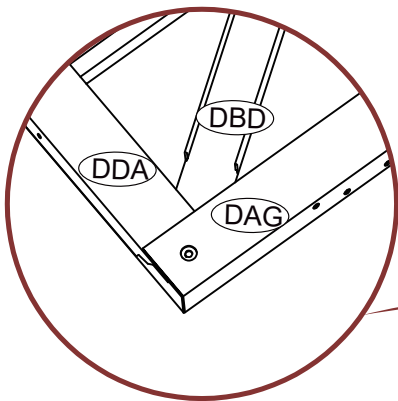
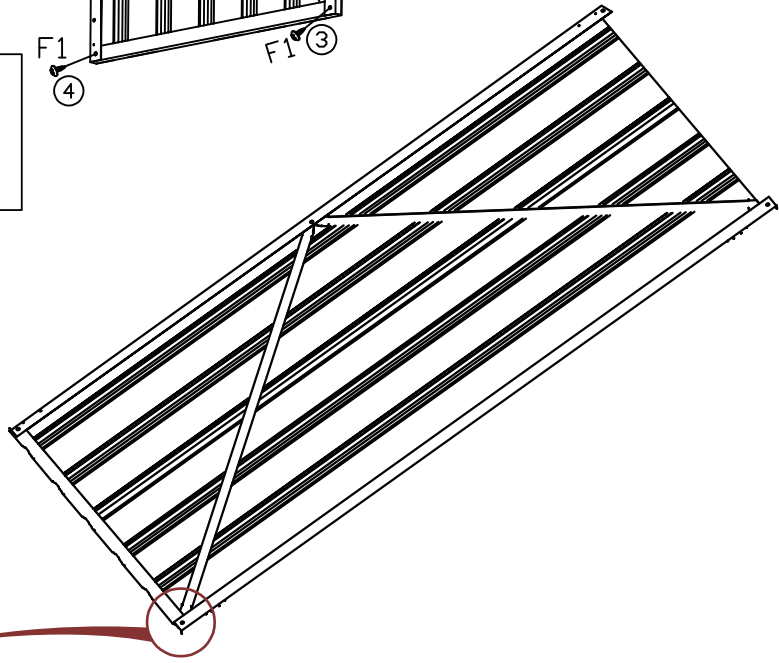

The two ends of the DBD crossbar must be assembled inside the door frame.



The cross pole DBD must be installed underneath DDA and DAG.

Attention: Installation sequence of screws ①—②—③—④—⑤—⑥—⑦

	F1	5
	F2	2

STEP 29

Right door panel splicing

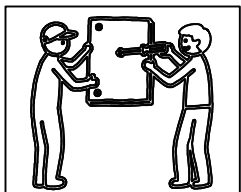
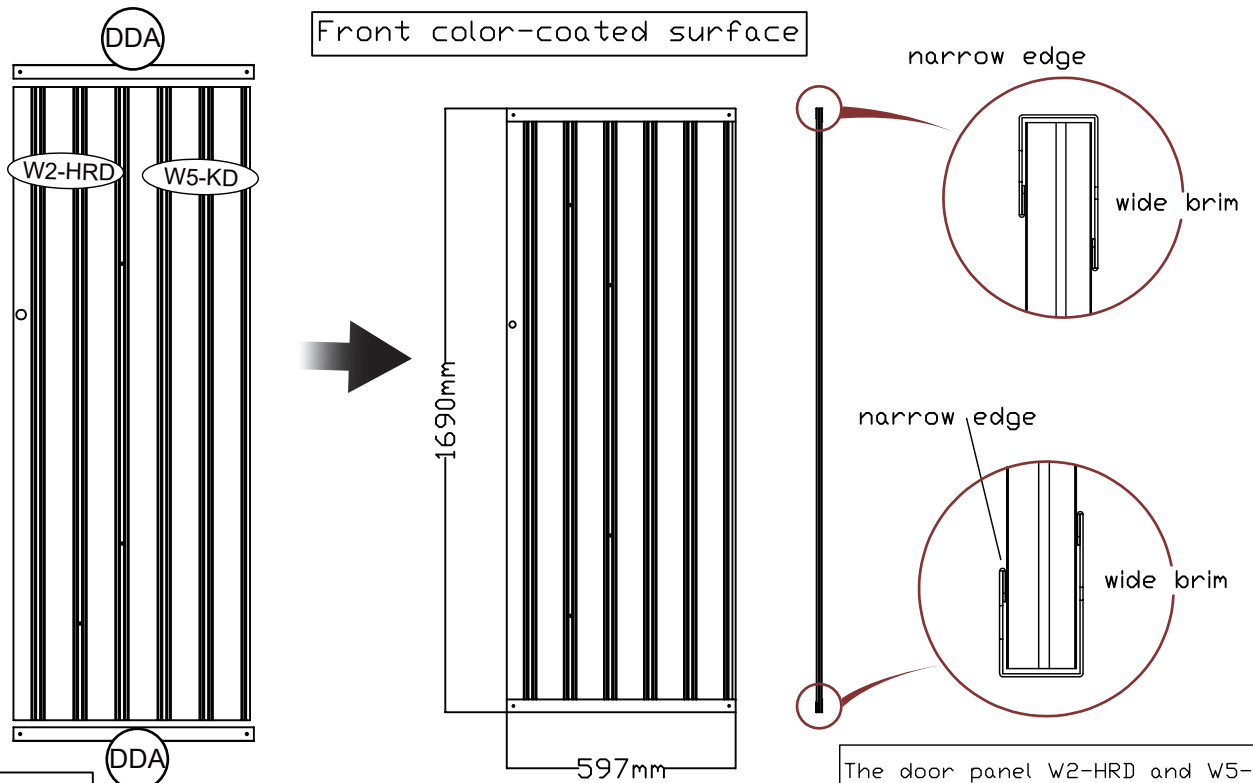
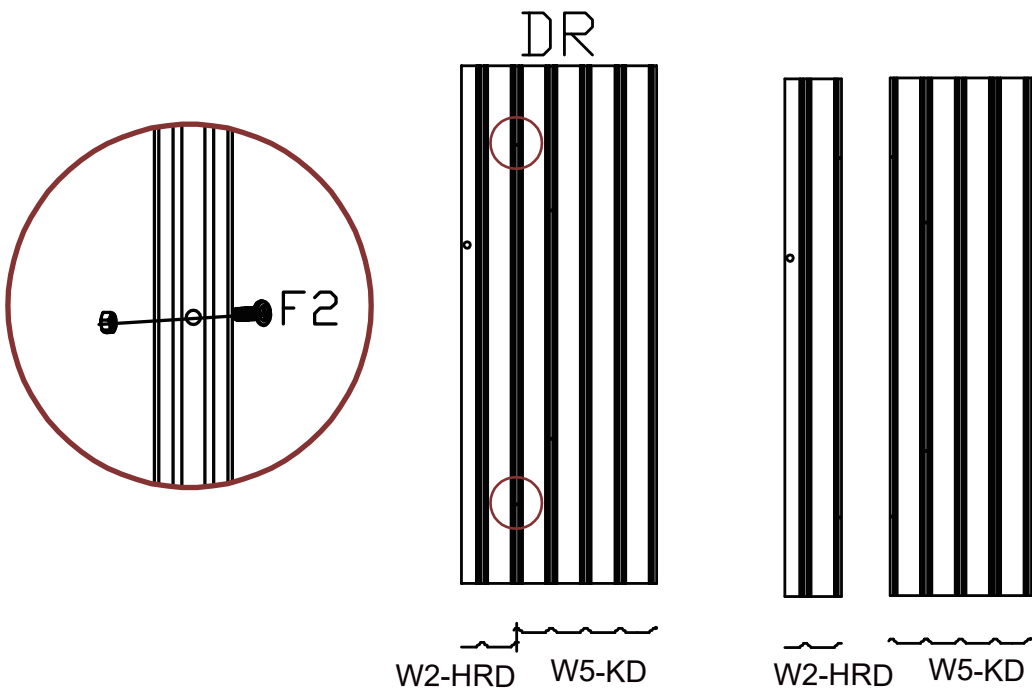

 This step requires two people to complete the installation together.

	F2	2
---	----	---

STEP 30

Right door panel splicing

positive

Front color-coated surface

Big hole on the outside, small hole on the inside, connected with an F1 screw.

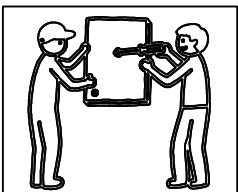
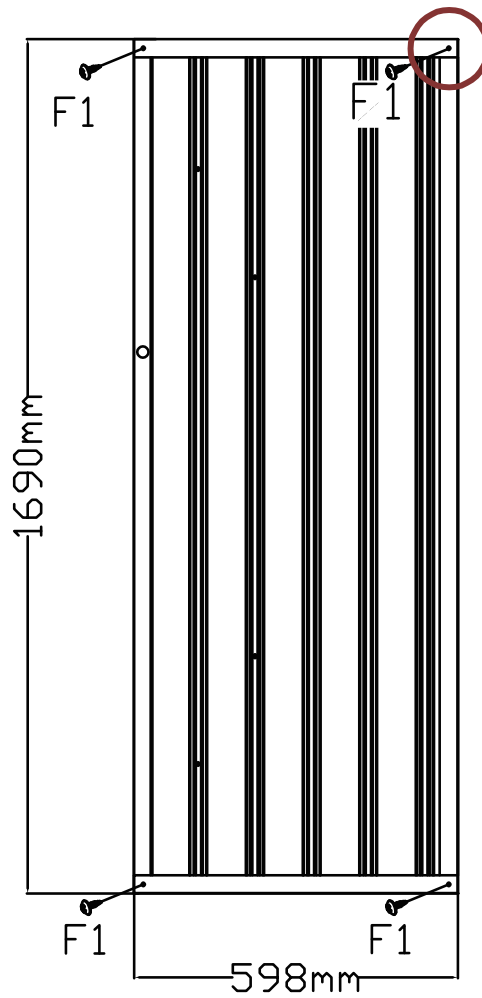
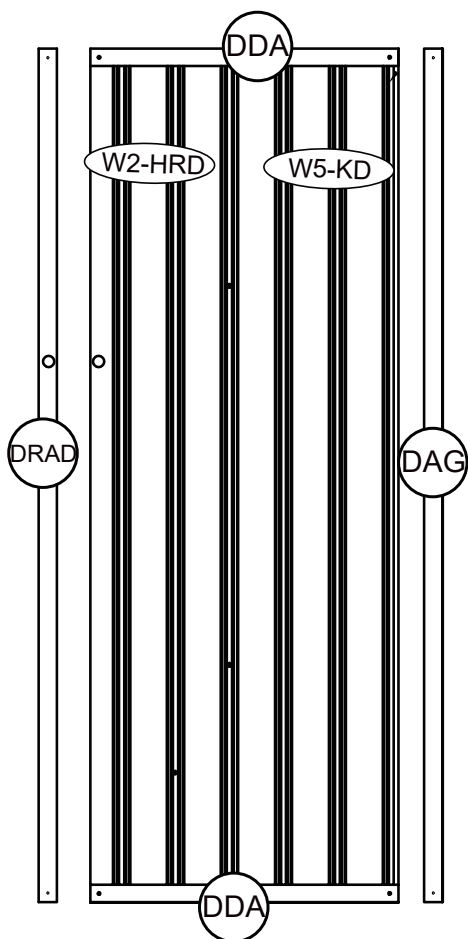
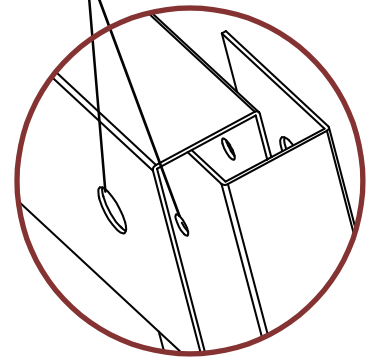
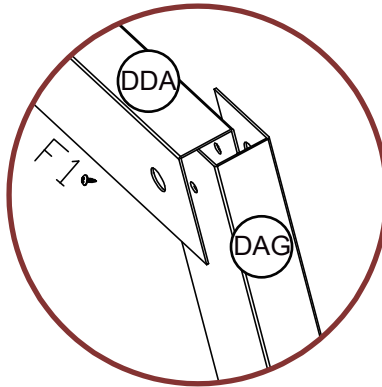
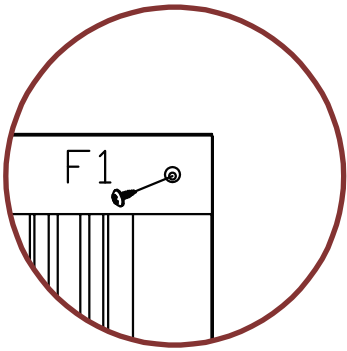

This step requires two people to complete the installation together.

	F4	4
---	----	---

STEP 31

Right door panel splicing

Attention: Installation sequence of screws ①—②—③—④—⑤—⑥—⑦

F1: ① ② ③ ④ ⑤

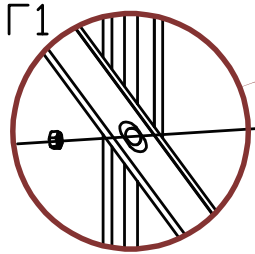
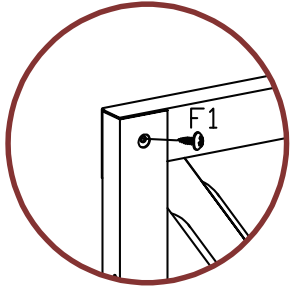

F2: ⑥ ⑦

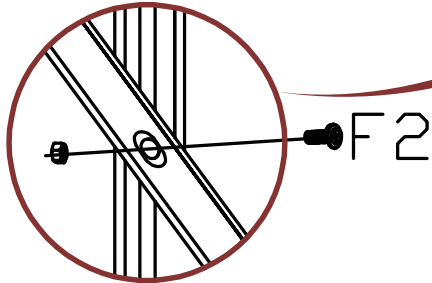

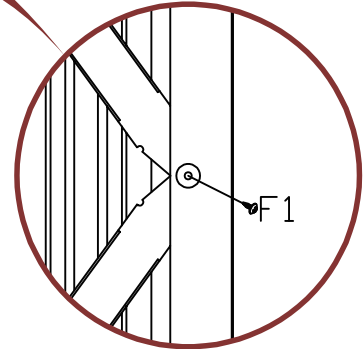
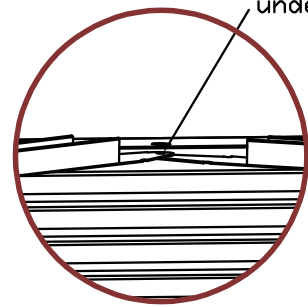
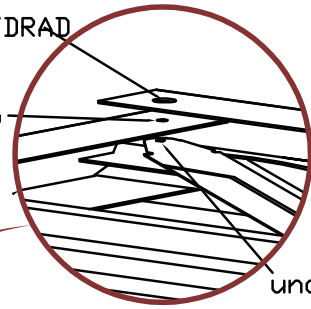
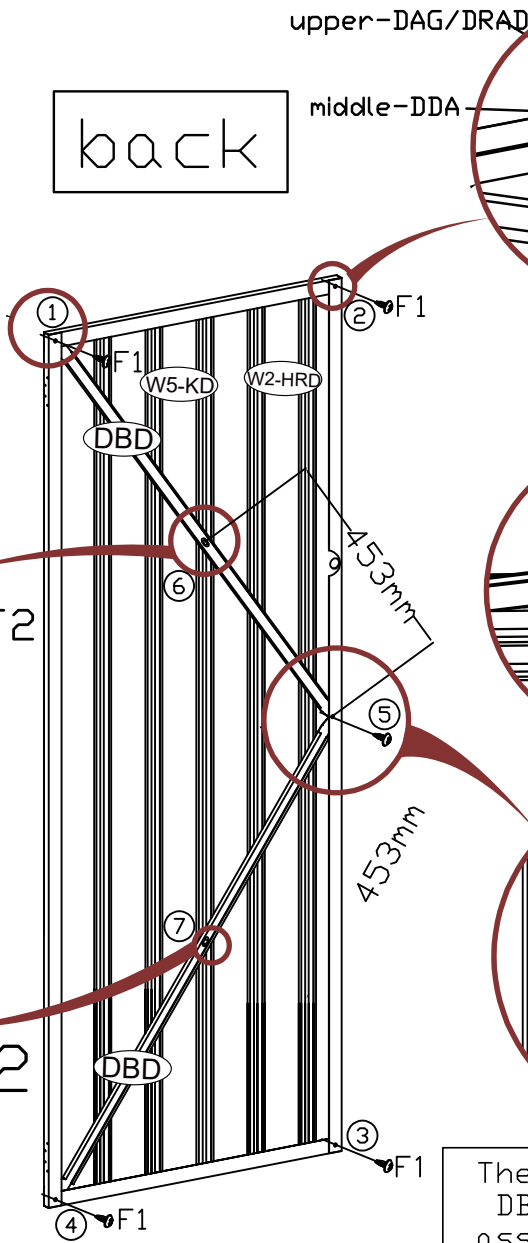

back

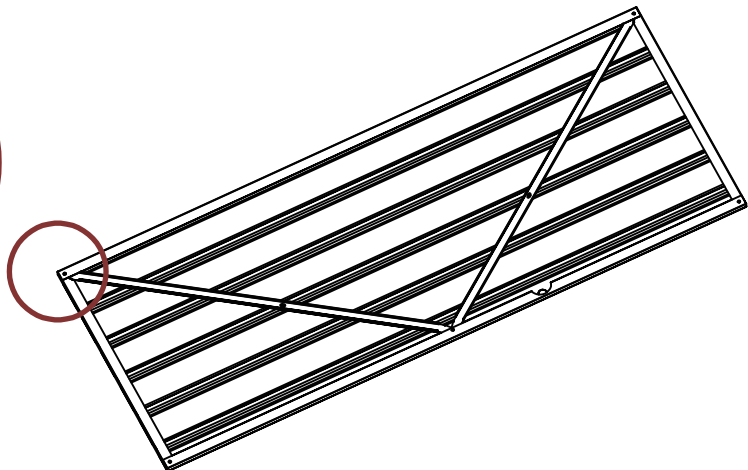
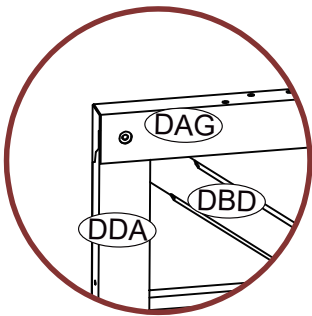

The two ends of the DBD crossbar must be assembled inside the door frame.



The cross pole DBD must be installed underneath DDA and DAG.

	F1	5
	F2	2

STEP 32

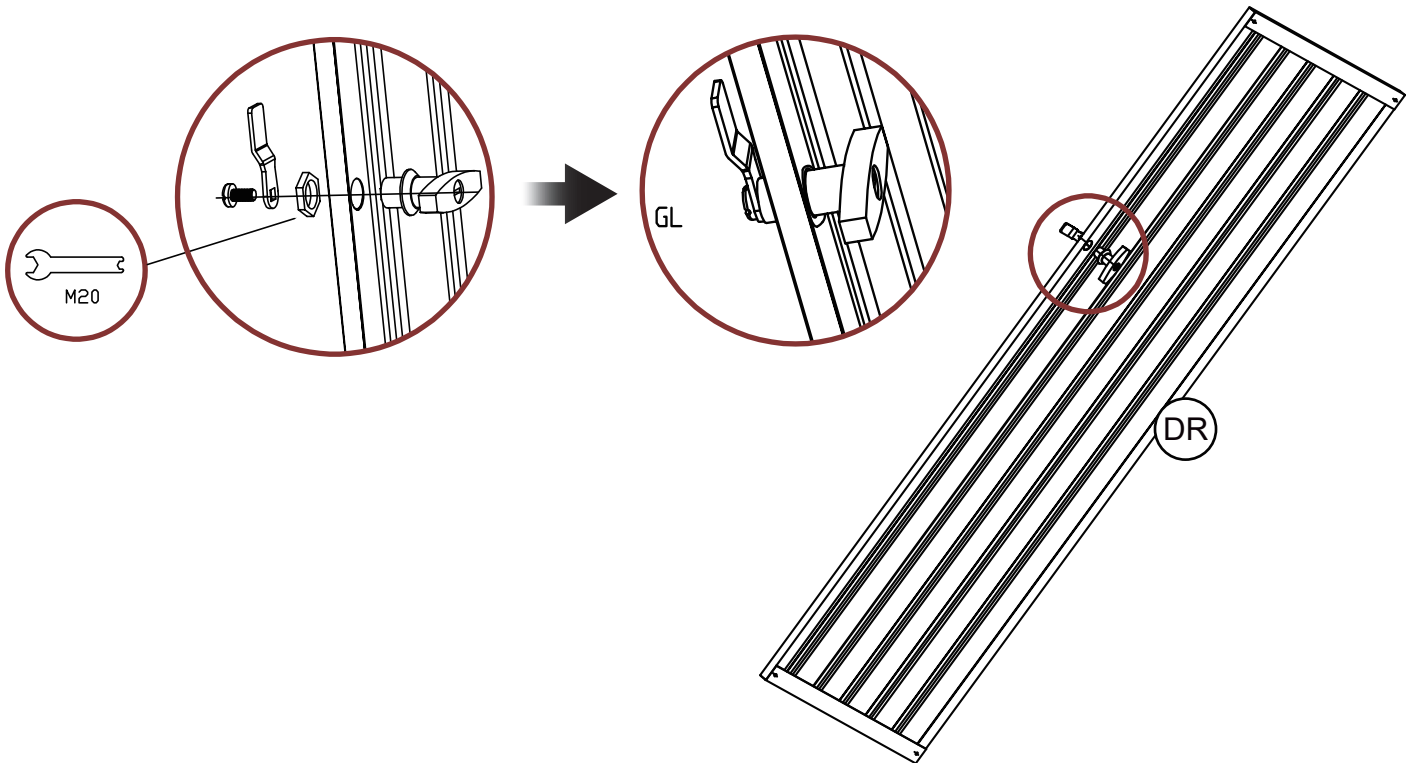
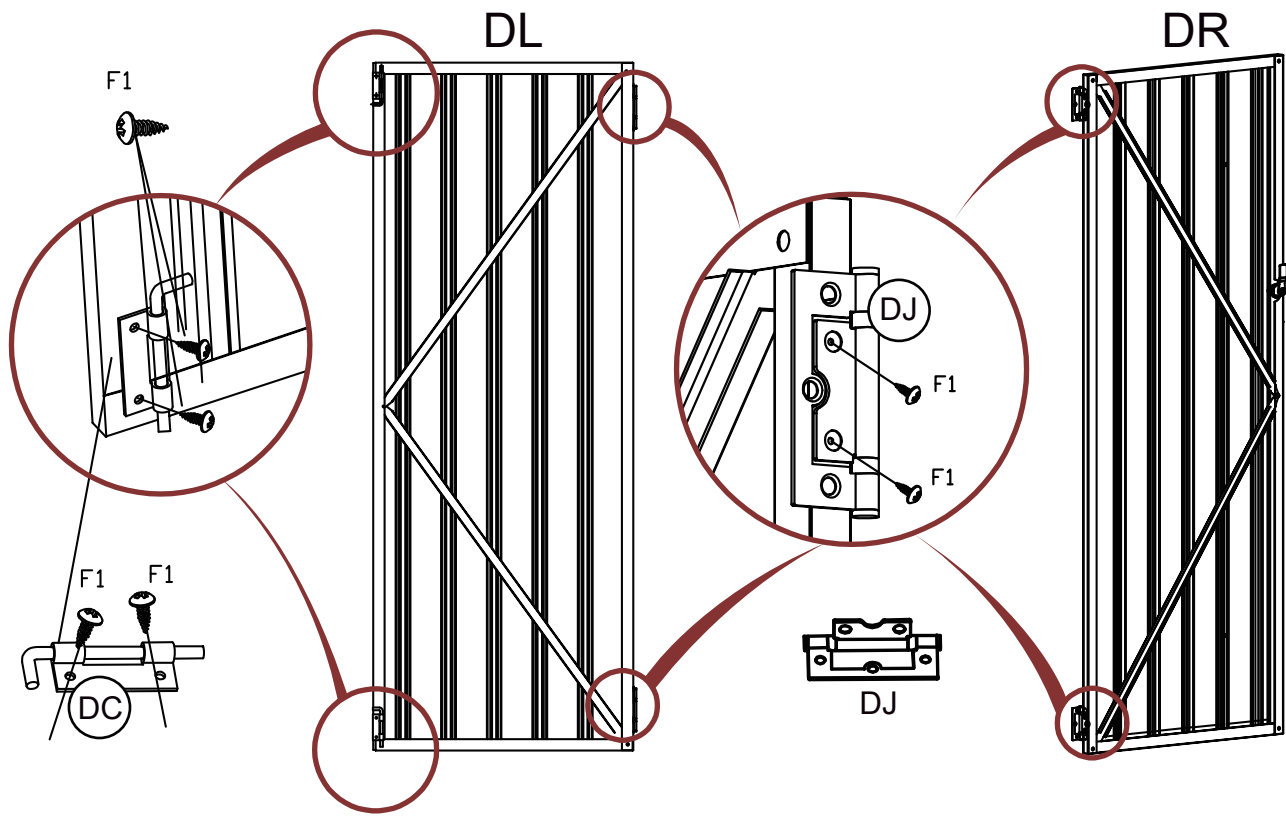

	F1	12
---	----	----

STEP 33

F1

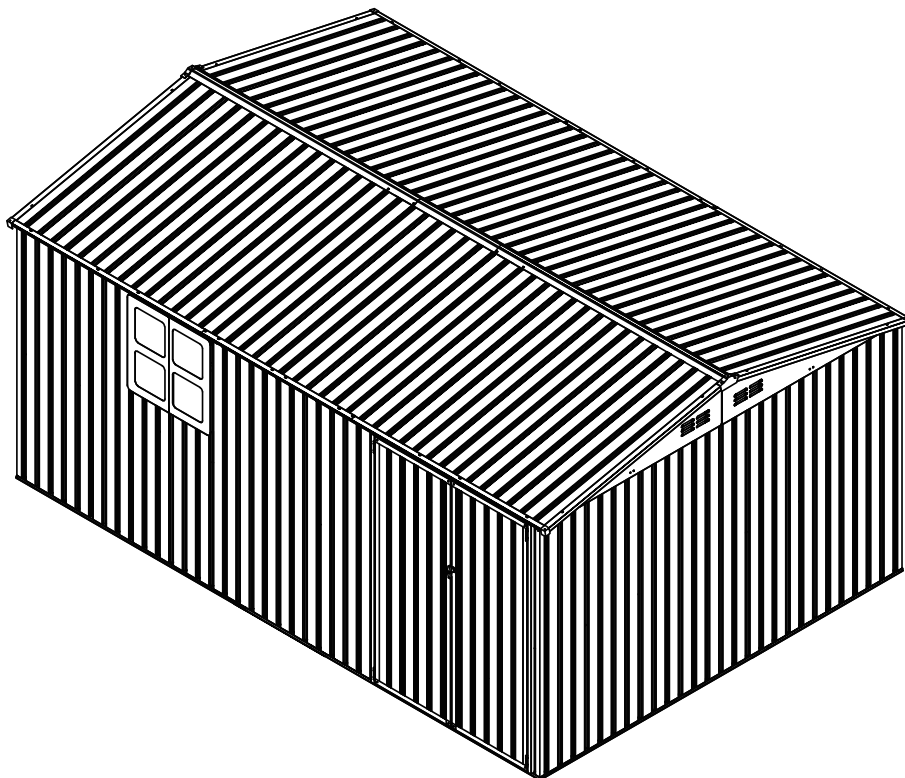
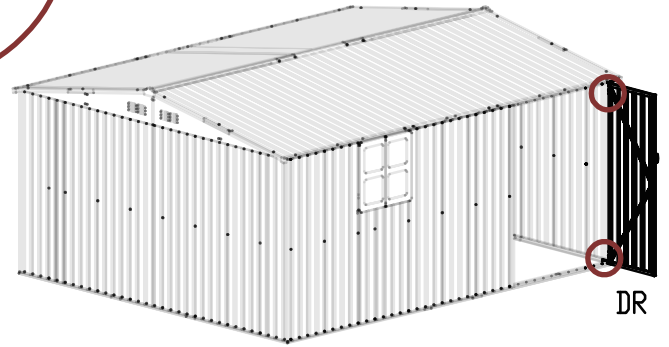
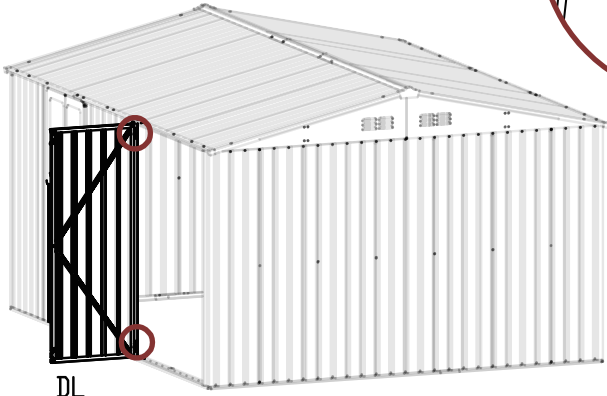
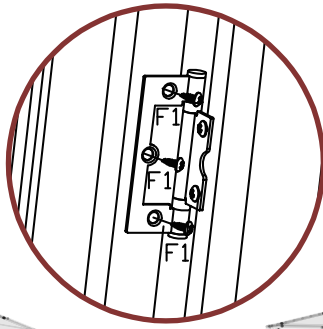

	F1	12
---	----	----

STEP 34

The exposed part of the assembly screw of the upper crossbeam support rod K1012-11 needs to be covered with a plastic protective cap.

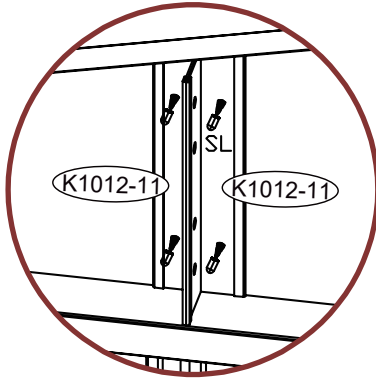

The exposed parts of the assembly screws for the upper crossbeam K1014-6L/K1014-6M/K1014-6R need to be covered with plastic protective caps.

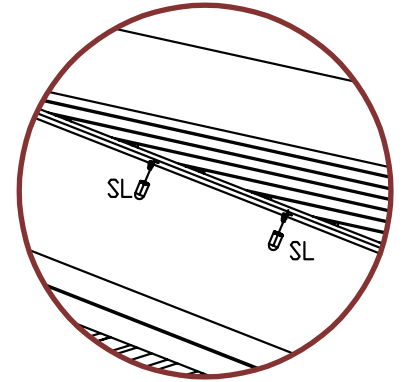
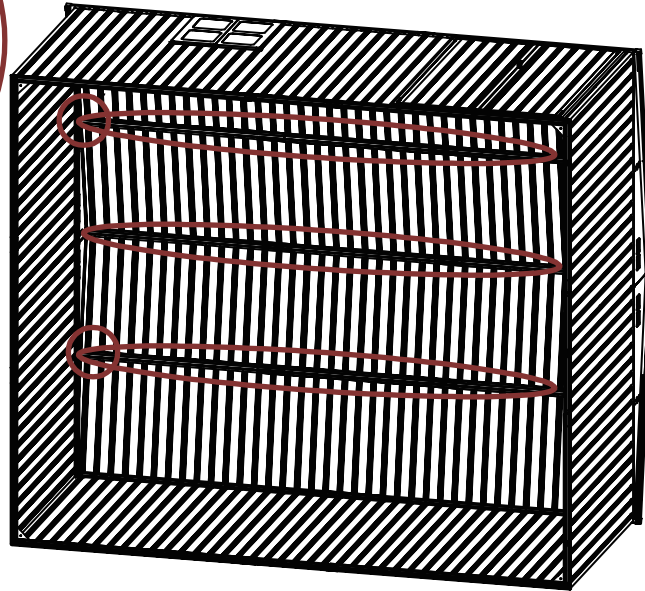

The exposed part of DJ assembly screws needs to be covered with a plastic protective cap.

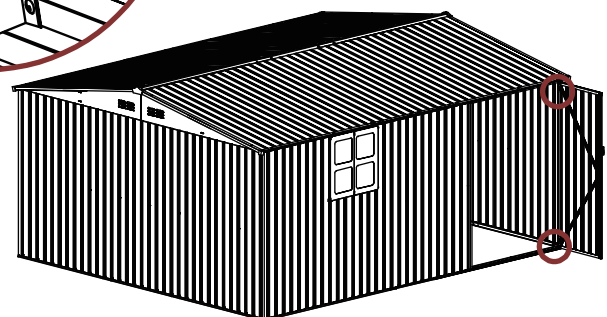
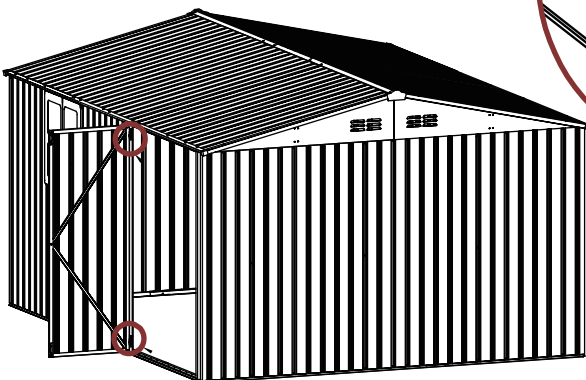
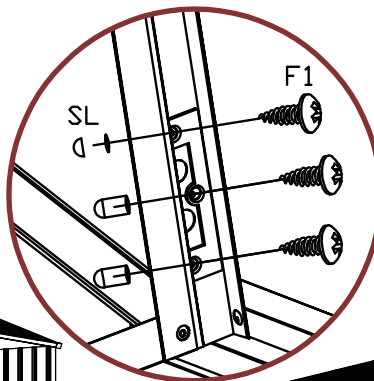

WARNING

ADULT ASSEMBLY REQUIRED

CHOKING HAZARD

- This product includes small parts, sharp points and sharp edges in its unassembled state.
- Keep unassembled parts away from children under 3 years of age, and animals.

SAFETY WARNINGS

- Follow the information on the warnings appearing on this manual.
- Do not allow children under 3 years of age to use the product.
- Do not use substitute parts. Contact the manufacturer for replacement parts.

USE, MAINTENANCE & ASSEMBLY

- Periodically check and ensure that the components are in their proper position, free from damage, and that all connectors are tight.
- Use on level surfaces only. Assemble on a soft level surface to avoid damage to unit or floor.
- Do not use this item if any components are missing or damaged.
- Only clean using damp cloth and mild detergent, do not use bleach or abrasive cleaners.

CARE & SAFETY

- Unsuitable for storage of flammable or corrosive substances.
- It is of utmost importance to assemble all of the parts according to the directions. Do not skip any step.
- Please consult your local authorities if any permits are required to erect shed.
- Periodically check shed to assure that it remains stable and that the site remains level.
- It is highly recommended to secure the shed to an immovable object or to the ground by drilling holes in the floor at the pre-marked locations and inserting proper screws into the ground (screws are not included).
- Wear safety-goggles and always follow the manufacturer's instructions when using power tools.
- Wash shed with garden hose or a mild detergent solution. Using a stiff brush or abrasive cleaner could damage shed.
- Hot items such as recently used grills, blowtorches, etc. Must not be stored in the shed.
- Heavy articles should not be leaned against the walls, as this may cause distortion.
- Keep roof clean of snow and leaves. Heavy amounts of snow on roof can damage the shed making it unsafe to enter.
- Although wind direction varies, it is an important factor when taking into account where to place your shed. Therefore, it is recommended to reduce wind exposure of the shed in general, and the door side in particular.
- Keep doors closed and locked to prevent wind damage.
- Do not stand on the roof.

RETURN REQUEST

In order to get a full refund as described in this return policy, all items must be:

- (1) In a brandnew/unused condition, please provide photos before and after packaging.
 - (2) When returning, all accessories and parts are firmly packed in all original packaging.
- If your return does not meet the requirements, you may not get a full refund.

When will I be refunded?

The refund is released once the goods have been returned to our warehouse.

What if the product is damaged/defective outside of the valid return period?

We want you to be a happy customer. Please reach out to us by email and we will come up with a solution to make sure you are satisfied.

