

KING BED ASSEMBLY INSTRUCTIONS

BOX#1

- A. HEADBOARD 1 PC
- B. HEADBOARD LEG 2 PCS

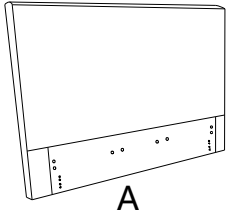

HARDWARE PACKED IN BOX#2

1	ALLEN BOLT(5/16"x1")		8 PCS
2	ALLEN BOLT(5/16"x2-1/2")		8 PCS
3	FLAT WASHER(5/16")		24 PCS
4	LOCK WASHER(5/16")		16 PCS
5	WASHER(2")		4 PCS
6	WRENCH(5/16")		1 PC
7	ALLEN KEY(5/16")		1 PC
8	HEX NUT(5/16"x12)		8 PCS

BOX#2

- B. FOOTBOARD LEG 2 PCS
 - C. SIDE RAIL 2 PCS
 - D. FOOTBOARD 1 PC
 - E. SLAT 39 PCS
 - F. CENTER SLAT SUPPORT 2 PCS
 - G. SIDE RAIL SLAT CLIP 26 PCS
 - H. CENTER SUPPORT SLAT CLIP 26 PCS
 - I. SLAT SUPPORT LEG 4 PCS
- HARDWARE SET



B

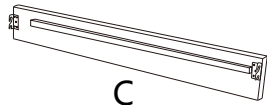

C

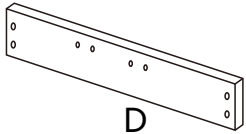

D

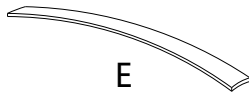

E

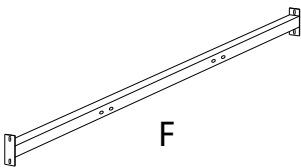

F

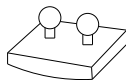

G

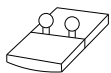

H

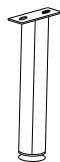

I

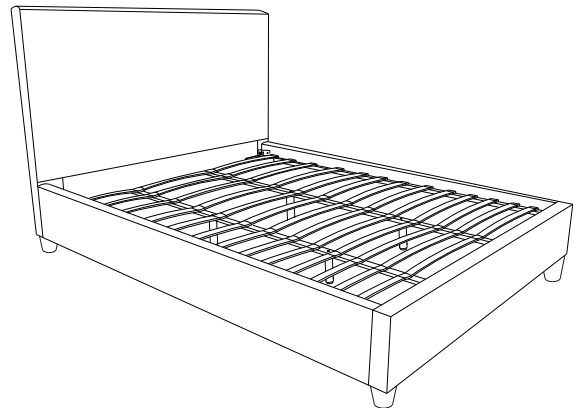

UPDATED: MAY 5TH, 2021



KING BED ASSEMBLY INSTRUCTIONS

STEP 1

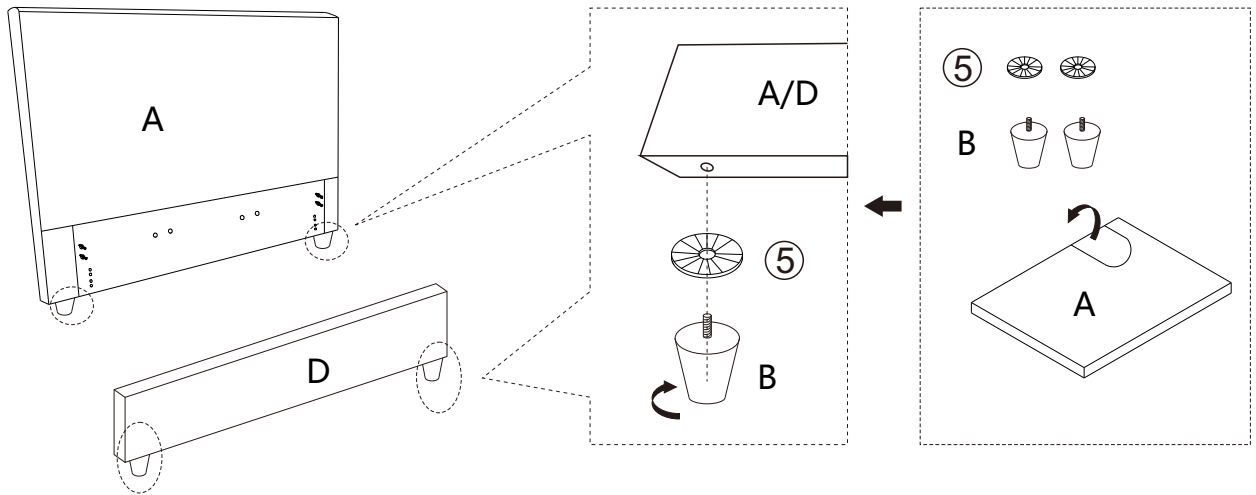

NOTE: USE FOOTBOARD LEG (B) PACKED IN BOX #2 FOR ASSEMBLY TO FOOTBOARD (D).

STEP 2

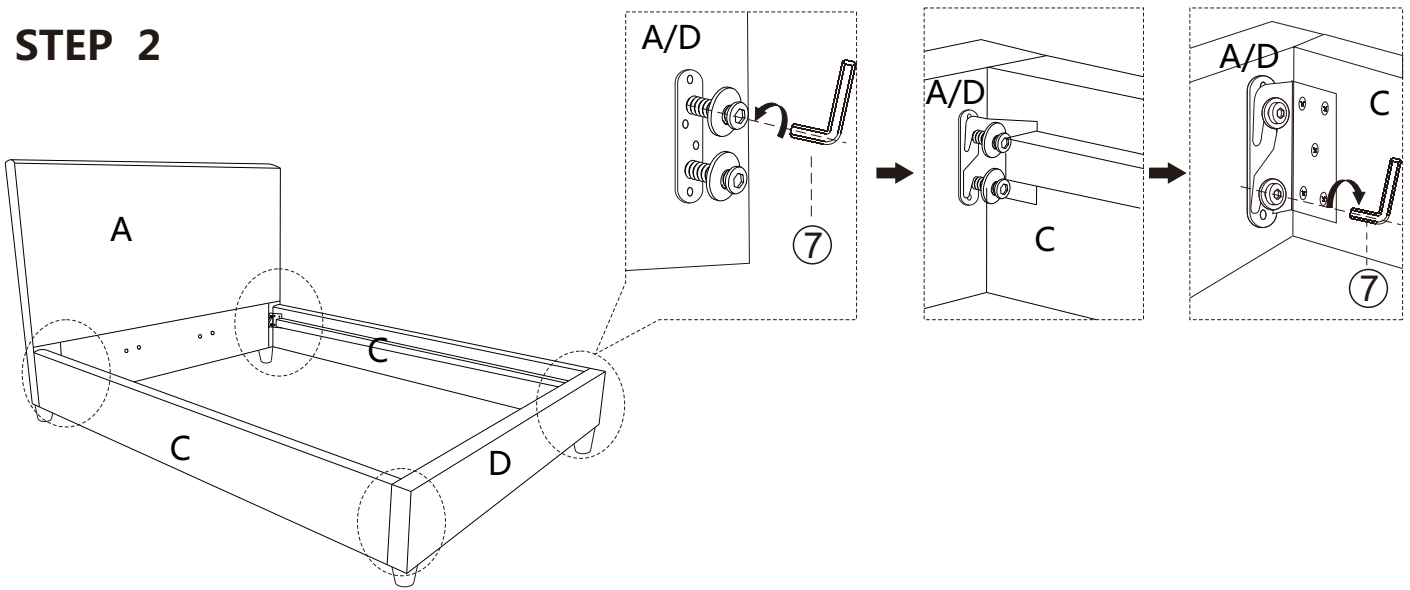

STEP 3

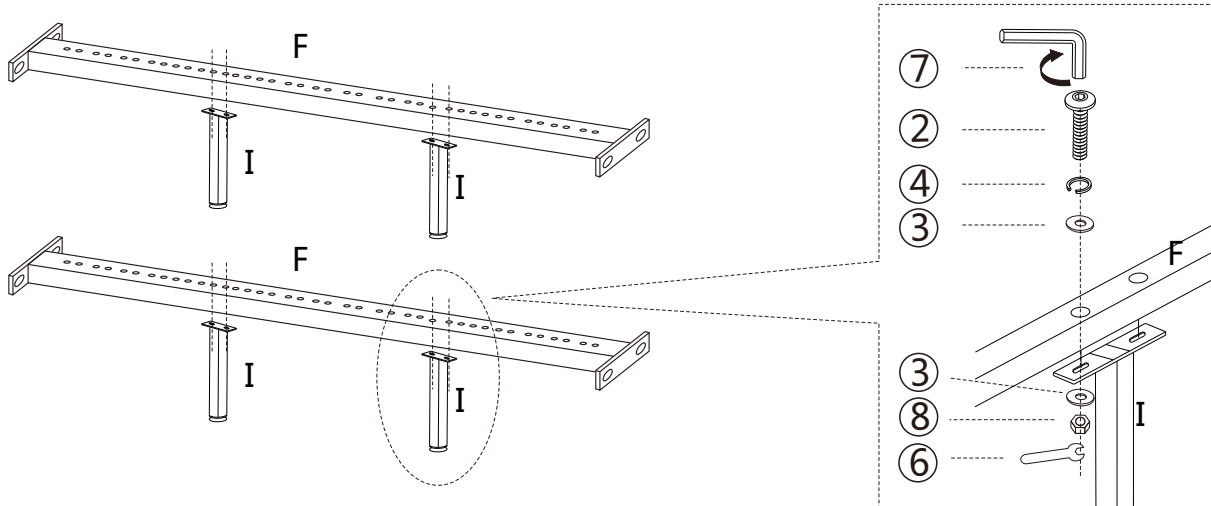

KING BED ASSEMBLY INSTRUCTIONS

STEP 4

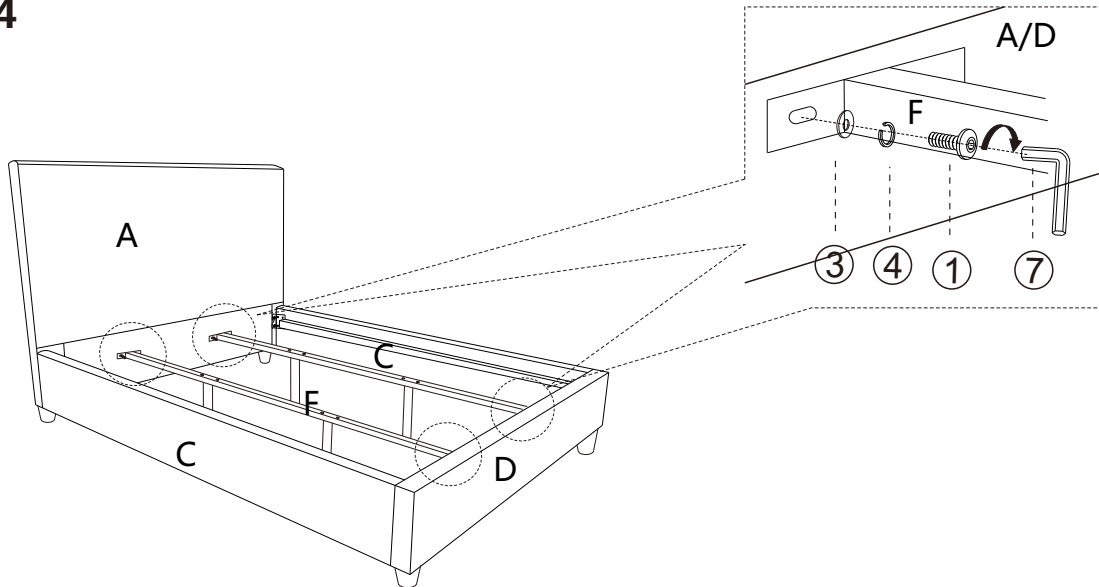

STEP 5

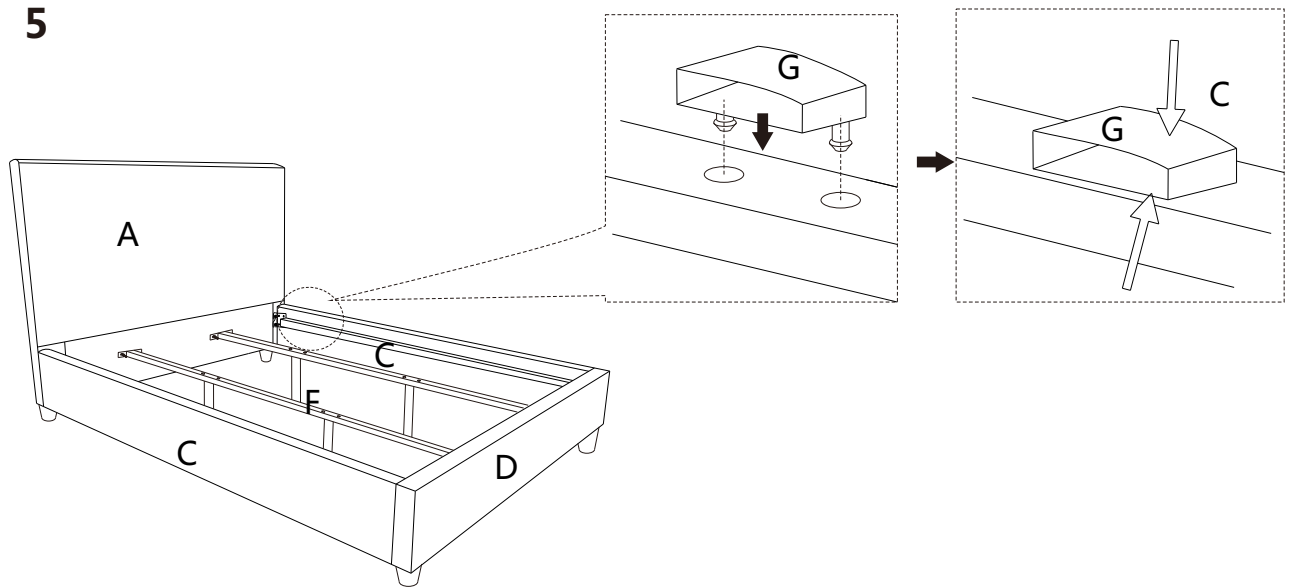

STEP 6

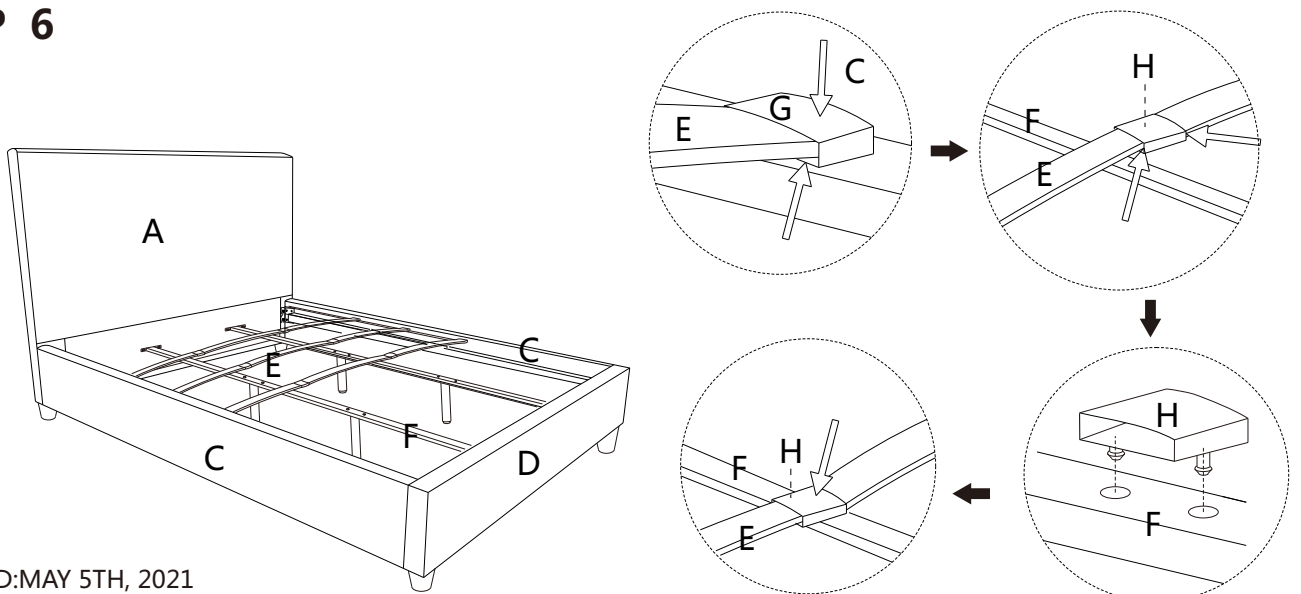

KING BED ASSEMBLY INSTRUCTIONS

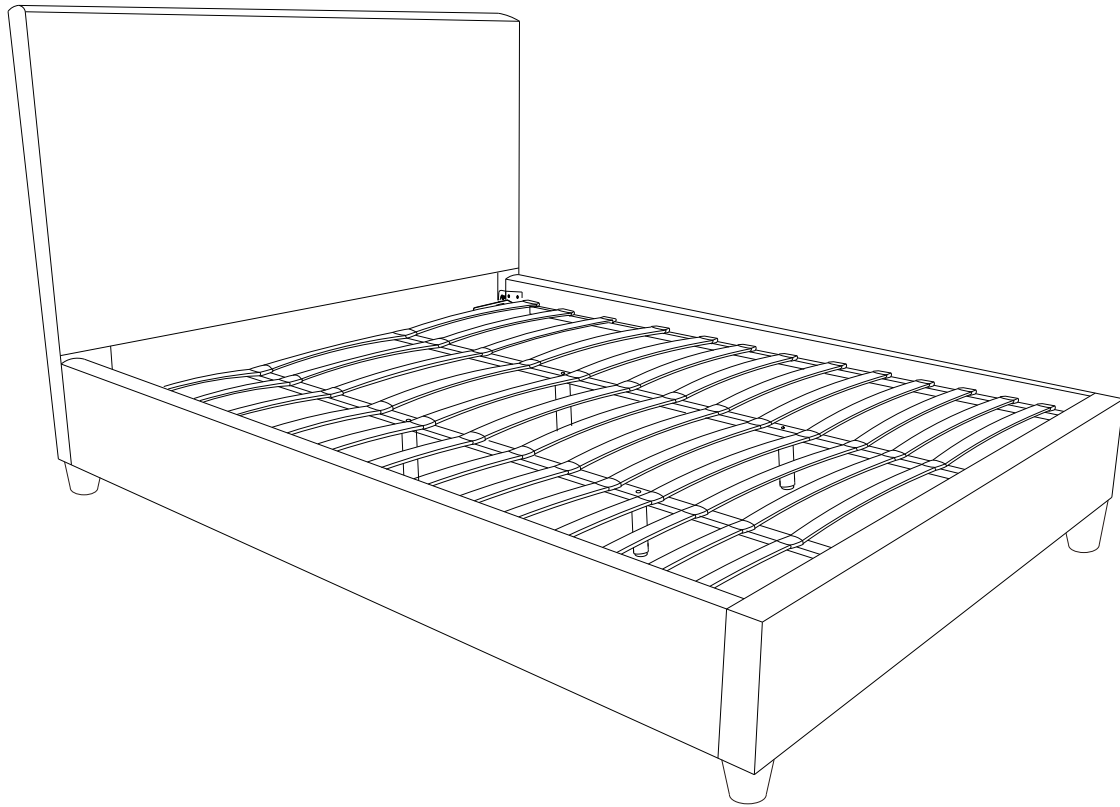

ASSEMBLY COMPLETE.

INSTRUCTIONS FOR ADJUSTING LEVELERS:

Position the bed in your space and locate the leveler under each support leg (I).

Turn the leveler counter-clockwise to extend the leveler and clockwise to retract it.

Adjust each leveler until each support leg is applying equal, upward pressure on the bed support slat.

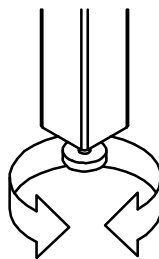

MAINTENANCE INSTRUCTIONS:

- Remove box spring and mattress before moving your bed.
- Lift your bed when moving it. Dragging can damage the support leg.
- Readjust levelers after moving your bed.

UPDATED: MAY 5TH, 2021